

# PIR Sensor (#555-28027)

## General Description

The PIR (Passive Infra-Red) Sensor is a pyroelectric device that detects motion by measuring changes in the infrared levels emitted by surrounding objects. This motion can be detected by checking for a high signal on a single I/O pin.

## Features

- Single bit output
- Small size makes it easy to conceal
- Compatible with all Parallax microcontrollers
- 3.3V & 5V operation with <100uA current draw

## Application Ideas

- Alarm Systems
- Halloween Props

## Quick Start Circuit

Note: The sensor is active high when the jumper (shown in the upper left) is in either position.

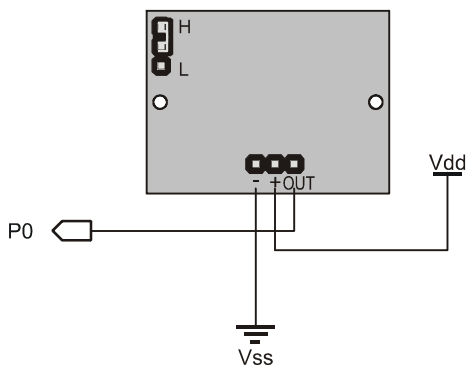

## Module Dimensions

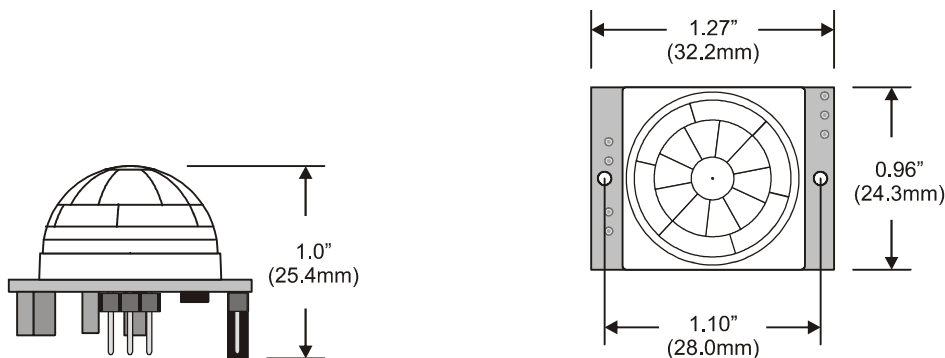

## Theory of Operation

Pyroelectric devices, such as the PIR sensor, have elements made of a crystalline material that generates an electric charge when exposed to infrared radiation. The changes in the amount of infrared striking the element change the voltages generated, which are measured by an on-board amplifier. The device contains a special filter called a Fresnel lens, which focuses the infrared signals onto the element. As the ambient infrared signals change rapidly, the on-board amplifier trips the output to indicate motion.

## Pin Definitions and Ratings

Pin	Name	Function
-	GND	Connects to Ground or Vss
+	V+	Connects to Vdd (3.3V to 5V) @ ~100uA
OUT	Output	Connects to an I/O pin set to INPUT mode (or transistor/MOSFET)

## Jumper Setting

Position	Mode	Description
H	Retrigger	Output remains HIGH when sensor is retriggered repeatedly. Output is LOW when idle (not triggered).
L	Normal	Output goes HIGH then LOW when triggered. Continuous motion results in repeated HIGH/LOW pulses. Output is LOW when idle.

## Connecting and Testing

Connect the 3-pin header to your circuit so that the minus (-) pin connects to ground or Vss, the plus (+) pin connects to Vdd and the OUT pin connects to your microcontroller's I/O pin. One easy way to do this would be to use a standard servo/LCD extension cable, available separately from Parallax (#805-00002). This cable makes it easy to plug sensor into the servo headers on our Board Of Education or Professional Development Board. If you use the Board Of Education, be sure the servo voltage jumper (located between the 2 servo header blocks) is in the Vdd position, not Vin. If you do not have this jumper on your board you should manually connect to Vdd through the breadboard. You may also plug the sensor directly into the edge of the breadboard and connect the signals from there. Remember the position of the pins when you plug the sensor into the breadboard.

## Calibration

The PIR Sensor requires a 'warm-up' time in order to function properly. This is due to the settling time involved in 'learning' its environment. This could be anywhere from 10-60 seconds. During this time there should be as little motion as possible in the sensors field of view.

## Sensitivity

The PIR Sensor has a range of approximately 20 feet. This can vary with environmental conditions. The sensor is designed to adjust to slowly changing conditions that would happen normally as the day progresses and the environmental conditions change, but responds by making its output high when sudden changes occur, such as when there is motion.

## Resources and Downloads

Check out the PIR Sensor product page for example programs and more:

[http://www.parallax.com/detail.asp?product\\_id=555-28027](http://www.parallax.com/detail.asp?product_id=555-28027)

# Source Code

## BASIC Stamp<sup>®</sup> 1 Program

This program will display the current status of the output pin from the PIR Sensor connected to P0 by lighting an active high LED connected to P1 when motion is detected.

```
' =====  
' File..... PIR_Simple.bs1  
' Purpose... Show Output State Of PIR Sensor  
' Author.... Parallax, Inc.  
' E-mail.... support@parallax.com  
' Started... 12-14-2005  
' {$STAMP BS1}  
' {$PBASIC 1.0}  
'  
' -----[ Program Description ]-----  
  
' This program displays the current state of the PIR Sensor connected to P0  
' by lighting an active high LED connected to P1 when motion is detected.  
  
' -----[ I/O Definitions ]-----  
  
SYMBOL          PIR =   PIN0          ' I/O Pin For PIR Sensor  
SYMBOL          LED =   PIN1          ' I/O Pin For LED  
  
' -----[ Initialization ]-----  
  
LET             DIRS = %00000010      ' Set Pin Directions  
  
' -----[ Program Code ]-----  
  
Main:  
  LET LED = PIR  
  GOTO Main
```

## BASIC Stamp<sup>®</sup> 2 Program

This program will display the current status of the output pin from the PIR Sensor connected to P0 using the Debug Terminal.

```
' =====  
' File..... PIR_Simple.bs2  
' Purpose... Show Output State Of PIR Sensor  
' Author.... Parallax, Inc.  
' E-mail.... support@parallax.com  
' Started... 12-14-2005  
' {$STAMP BS2}  
' {$PBASIC 2.5}  
'  
' -----[ Program Description ]-----  
  
' This program displays the current state of the PIR Sensor connected to P0  
' on the DEBUG screen.
```

```
' -----[ Program Code ]-----
Main:
  DO
    DEBUG HOME, BIN1 IN0      ' Display Status Of P0 At Home Pos.
    PAUSE 100                 ' Small Delay
  LOOP                       ' Repeat Forever
```

## SX Microcontroller Application

This program will display the current status of the output pin from the PIR Sensor connected to RC.7 by lighting an active high LED connected to RC.6 when motion is detected.

```
' =====
'
' File..... PIR_Simple.SXB
' Purpose... Demonstrate Reading The PIR Sensor
' Author.... Parallax, Inc.
' E-mail.... support@parallax.com
' Started... 12-14-2005
'
' Program Description
' -----
' This program will display the status of the output of the PIR sensor
' connected to RC.7 by lighting an active high LED connected to RC.6 when
' motion is detected. Use a 220 or 330 ohm series resistor with the LED.
'
' Device Settings
' -----
DEVICE          SX28, OSC4MHZ, TURBO, STACKX, OPTIONX
FREQ            4_000_000
'
' IO Pins
' -----
PIR             VAR          RC.7          ' I/O Pin For PIR Sensor
LED            VAR          RC.6          ' I/O Pin For LED
'
' Program Code
' -----
Start:
  TRIS_C       =          %10111111      ' Set I/O Pin Directions
Main:
  LED = PIR    ' Make LED Follow PIR
  GOTO Main
```



## Стандарт Электрон Связь

Мы молодая и активно развивающаяся компания в области поставок электронных компонентов. Мы поставляем электронные компоненты отечественного и импортного производства напрямую от производителей и с крупнейших складов мира.

Благодаря сотрудничеству с мировыми поставщиками мы осуществляем комплексные и плановые поставки широчайшего спектра электронных компонентов.

Собственная эффективная логистика и склад в обеспечивает надежную поставку продукции в точно указанные сроки по всей России.

Мы осуществляем техническую поддержку нашим клиентам и предпродажную проверку качества продукции. На все поставляемые продукты мы предоставляем гарантию .

Осуществляем поставки продукции под контролем ВП МО РФ на предприятия военно-промышленного комплекса России , а также работаем в рамках 275 ФЗ с открытием отдельных счетов в уполномоченном банке. Система менеджмента качества компании соответствует требованиям ГОСТ ISO 9001.

Минимальные сроки поставки, гибкие цены, неограниченный ассортимент и индивидуальный подход к клиентам являются основой для выстраивания долгосрочного и эффективного сотрудничества с предприятиями радиоэлектронной промышленности, предприятиями ВПК и научно-исследовательскими институтами России.

С нами вы становитесь еще успешнее!

### Наши контакты:

**Телефон:** +7 812 627 14 35

**Электронная почта:** [sales@st-electron.ru](mailto:sales@st-electron.ru)

**Адрес:** 198099, Санкт-Петербург,  
Промышленная ул, дом № 19, литера Н,  
помещение 100-Н Офис 331