

MAX 112 segments (SEG28xCOM4)

Multifunction LCD Segment Driver

BU97931FV-LB

This product guarantees long time support in Industrial market.

Features

- Long Time Support Product for Industrial Equipment
- Integrated RAM for display data (DDRAM):
28 x 4 bit (Max 112 Segment)
- LCD Drive Output:
4 Common Output, Max 28 Segment Output
- Integrated 1ch LED Driver Circuit
- Segment/GPO (Max 5port) Output Mode Selectable
- Support PWM Generation from ext. or Internal Clock
(Resolution: 8bit)
- Support Standby Mode
- Integrated Power-on-Reset Circuit (POR)
- Integrated Oscillator Circuit
- No External Component
- Low Power Consumption Design
- Independent Power Supply for LCD Driving
- Support Blink Function
(Blink frequency 1.6, 2.0, 2.6, 4.0Hz selectable)

Applications

- Industrial Equipment
- Telephone
- FAX
- Portable Equipment (POS, ECR, PDA etc.)
- DSC
- DVC
- Car audio
- Home Electrical Appliance
- Meter Equipment

Etc.

Typical Application Circuit

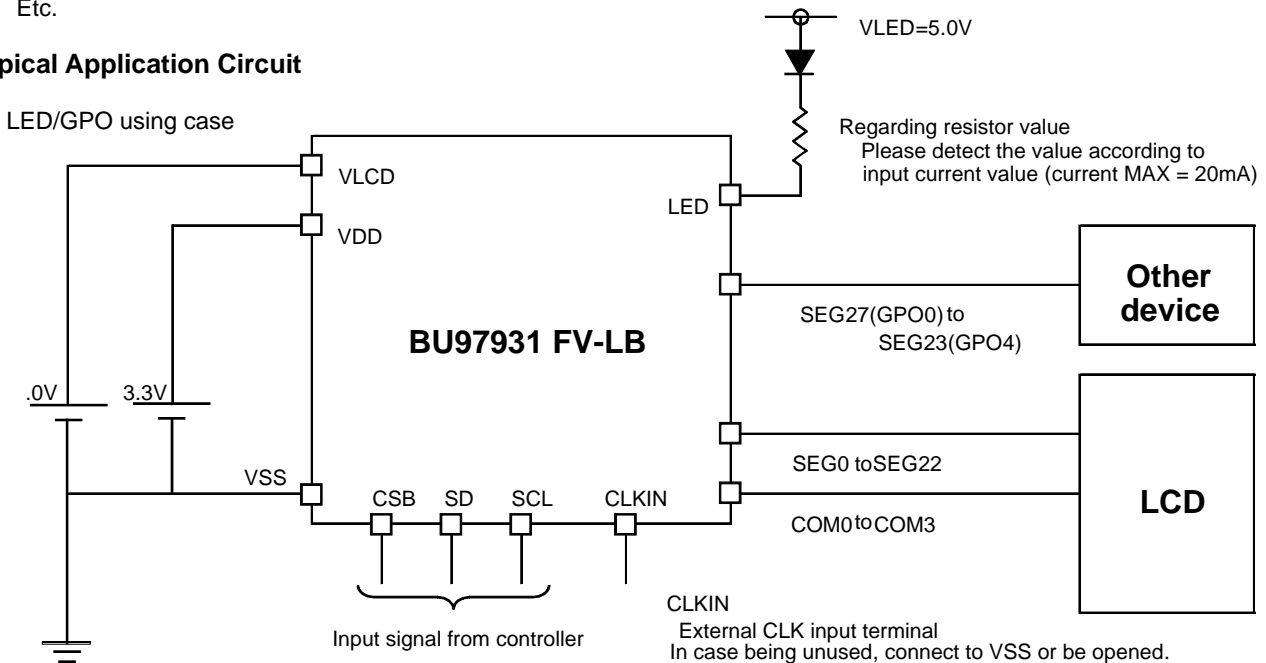

Figure 1. Typical application circuit

Key Specifications

- Supply Voltage Range: +1.8V to +3.6V
- LCD Drive Power Supply Range: +2.7V to +5.5V
- Operating Temperature Range: -40°C to +85°C
- Max Segments: 112 Segments
- Display Duty: Static, 1/3, 1/4 Selectable
- Bias: Static, 1/3
- Interface: 3Wire Serial Interface

Package

W (Typ) x D (Typ) x H (Max)

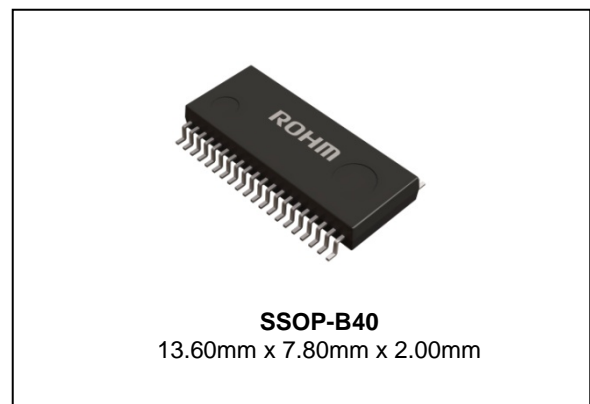

Block Diagram / Pin Configuration / Pin Description

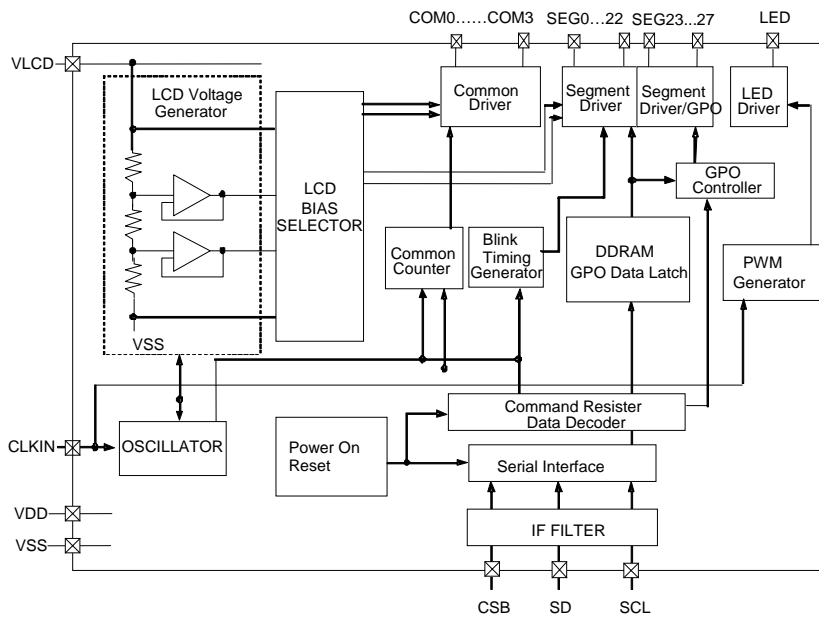

Figure 2. Block Diagram

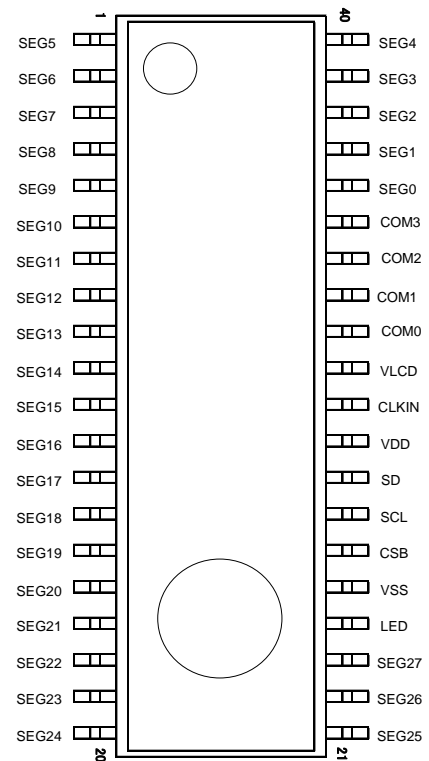

Figure 3. Pin Configuration (TOP VIEW)

Table 1 Pin Description

Terminal	Terminal Number	I/O	Unused Case	Function
CSB	26	I	-	Chip select: "L" active
SCL	27	I	-	Serial data transfer clock
SD	28	I	-	Input serial data
VDD	29	-	-	Power supply for LOGIC
CLKIN	30	I	OPEN / VSS	External clock input terminal (for display/PWM using selectable); Support Hi-Z input mode at internal clock mode
VSS	25	-	-	GND
VLCD	31	-	-	Power supply for LCD
COM0 to 3	32 to 35	O	OPEN	COMMON output for LCD
SEG0 to 22	36 to 40 1 to 18	O	OPEN	SEGMENT output for LCD
SEG23 to 27	19 to 23	O	OPEN	SEGMENT output for LCD/GPO
LED	24	O	OPEN	LED driver output

Absolute Maximum Ratings (VSS=0V)

Parameter	Symbol	Ratings	Unit	Remarks
Power Supply Voltage 1	VDD	-0.3 to +4.5	V	Power supply
Power Supply Voltage 2	VLCD	-0.5 to +7.0	V	Power supply for LCD
Power Dissipation	Pd	0.8	W	When operated more than Ta=25°C, subtract 8.0mW per degree. (using ROHM standard board) (board size:74.2mm×74.2mm×1.6mm material: FR4 board copper foil: land pattern only)
Input Voltage Range	VIN	-0.5 to VDD +0.5	V	
Operational Temperature Range	Topr	-40 to +85	°C	
Storage Temperature Range	Tstg	-55 to +125	°C	
Output current	Iout1	5	mA	SEG output
	Iout2	5	mA	COM output
	Iout3	10	mA	GPO output
	Iout4	50	mA	LED output

Caution: Operating the IC over the absolute maximum ratings may damage the IC. The damage can either be a short circuit between pins or an open circuit between pins and the internal circuitry. Therefore, it is important to consider circuit protection measures, such as adding a fuse, in case the IC is operated over the absolute maximum ratings.

Recommended Operating Conditions (Ta=-40°C to +85°C, VSS=0V)

Parameter	Symbol	Ratings			Unit	Remarks
		Min	Typ	Max		
Power Supply Voltage 1	VDD	1.8	-	3.6	V	Power supply
Power Supply Voltage 2	VLCD	2.7	-	5.5	V	Power supply for LCD
Output Current	Iout4	-	-	20	mA	Per LED port 1ch

Electrical Characteristics

DC characteristics (Ta= -40°C to +85°C, VDD=1.8V to 3.6V, VLCD=3.3V to 5.5V, VSS=0)

Parameter	Symbol	Limits			Unit	Conditions
		Min	Typ	Max		
"H" Level Input Voltage	VIH	0.8VDD	-	VDD	V	SD, SCL, CSB, CLKIN
"L" Level Input Voltage	VIL	VSS	-	0.2VDD	V	SD, SCL, CSB, CLKIN
Hysteresis Width	VH	-	0.2	-	V	SCL, VDD=3.3V, Ta=25°C
"H" Level Input Current	IiH1	-	-	5	µA	SD, SCL, CSB, CLKIN, VI=3.6V
"L" Level Input Current	IiL1	-5	-	-	µA	SD, SCL, CSB, CLKIN, VI=0V
"H" Level Output Voltage (Note2)	VOH1	VLCD -0.4	-	-	V	Iload=-50µA, VLCD=5.0V SEG0 to SEG27
	VOH2	VLCD -0.4	-	-	V	Iload=-50µA, VLCD=5.0V, COM0 to COM3
	VOH3	VLCD -0.6	-	-	V	Iload=-1mA, VLCD=5.0V, SEG23 to SEG27(GPO mode)
"L" Level Output Voltage (Note2)	VOL1	-	-	0.4	V	Iload= 50µA, VLCD=5.0V, SEG0 to SEG27
	VOL2	-	-	0.4	V	Iload= 50µA, VLCD=5.0V, COM0 to COM3
	VOL3	-	-	0.5	V	Iload=1mA, VLCD=5.0V, SEG23 to SEG27(GPO mode)
	VOL4	-	0.11	0.5	V	Iload=20mA, VLCD=5.0V, LED

(Note 1) Power save mode 1 and frame inversion setting

(Note 2) Iload: In this case, load current from only one port

Electrical Characteristics – continued

DC characteristics (Ta= -40°C to +85°C, VDD=1.8V to 3.6V, VLCD=3.3V to 5.5V, VSS=0)

Parameter	Symbol	Limits			Unit	Conditions
		Min	Typ	Max		
Current Consumption ^(Note1)	IstVDD	-	3	10	μA	Input terminal ALL'L', Display off, Oscillation off
	IstVLCD	-	0.5	5	μA	Input terminal ALL'L', Display off, Oscillation off
	IVDD1	-	8	15	μA	VDD=3.3V, Ta=25°C, 1/3bias, fFR=64Hz, PWM generate off, All output pin open
	IVDD2	-	30	45	μA	VDD=3.3V, Ta=25°C, 1/3bias, fFR=64Hz, PWM Frequency=500Hz setting, All output pin open
	IVLCD1	-	10	15	μA	VLCD=5.0V, Ta=25°C, 1/3bias, fFR=64Hz, LED generate off, All output pin open
	IVLCD2	-	30	48	μA	VLCD=5.0V, Ta=25°C, 1/3bias, fFR=64Hz, PWM Frequency=500Hz setting, All output pin open

(Note 1) Power save mode 1 and frame inversion setting

(Note 2) Iload: In case, load current from only one port

Oscillation Frequency Characteristics (Ta= -40°C to +85°C, VDD=1.8V to 3.6V, VLCD=2.7V to 5.5V, VSS=0)

Parameter	Symbol	Limits			Unit	Conditions
		Min	Typ	Max		
Frame Frequency 1	fFR1	57.6	64	70.4	Hz	VDD=3.3V, Ta=25°C, fFR=64Hz setting
Frame Frequency 2	fFR2	51.2	64	73.0	Hz	VDD=2.5V to 3.6V fFR=64Hz setting
Frame Frequency 3	fFR3	45.0	-	64	Hz	VDD=1.8V to 2.5V fFR=64Hz setting

About detail function, please refer to the frame frequency setting of DISCTL command.

MPU Interface Characteristics (Ta= -40°C to +85°C, VDD=1.8V to 3.6V, VLCD=2.7V to 5.5V, VSS=0)

Parameter	Symbol	Limits			unit	Conditions
		Min	Typ	Max		
Input Rise Time	tr	-	-	50	ns	
Input Fall Time	tf	-	-	50	ns	
SCL Cycle Time	tSCYC	250	-	-	ns	
“H” SCL PulseWwidth	tSHW	50	-	-	ns	
“L” SCL Pulse Width	tSLW	50	-	-	ns	
SD Setup Time	tSDS	50	-	-	ns	
SD Hold Time	tSDH	50	-	-	ns	
CSB Setup Time	tCSS	50	-	-	ns	
CSB Hold Time	tCSH	50	-	-	ns	
“H” CSB Pulse Width	tCHW	50	-	-	ns	

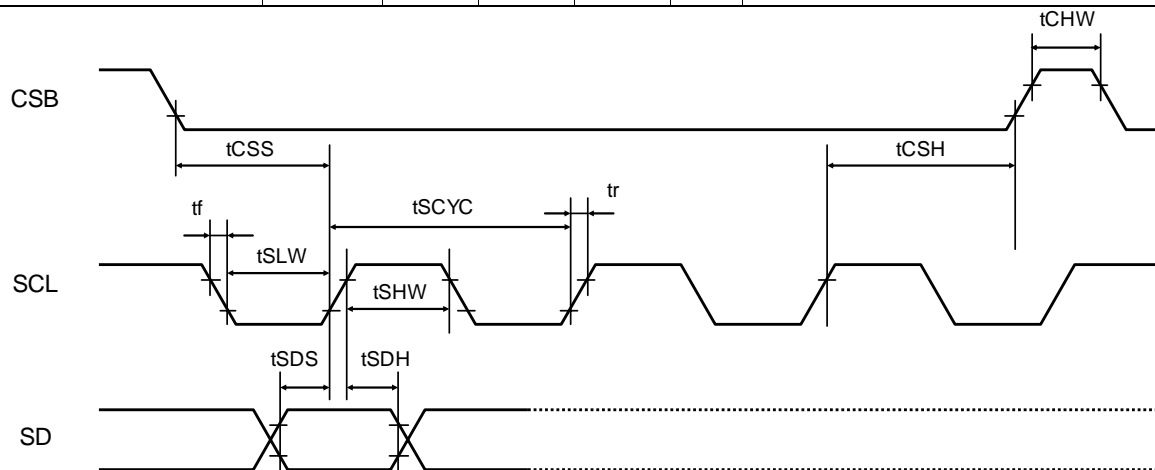

Figure 4. Serial Interface Timing

I/O Equivalence Circuit

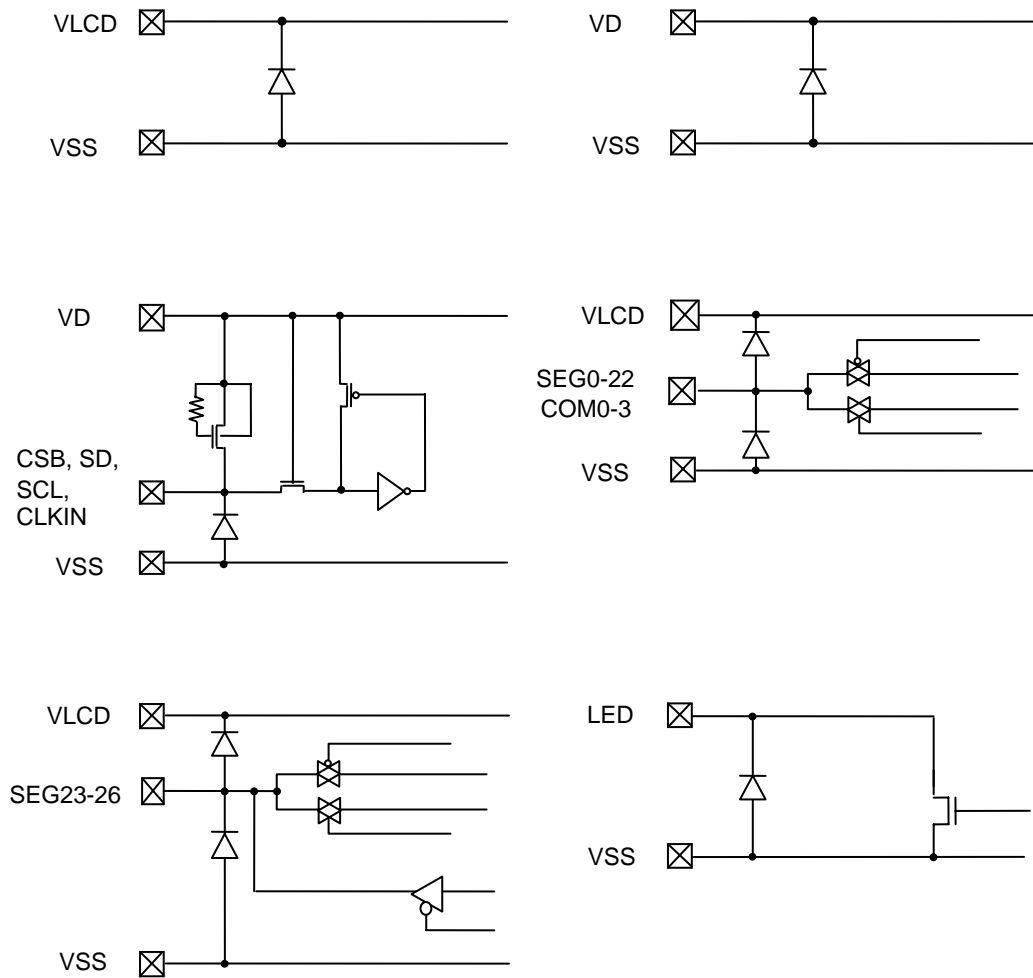
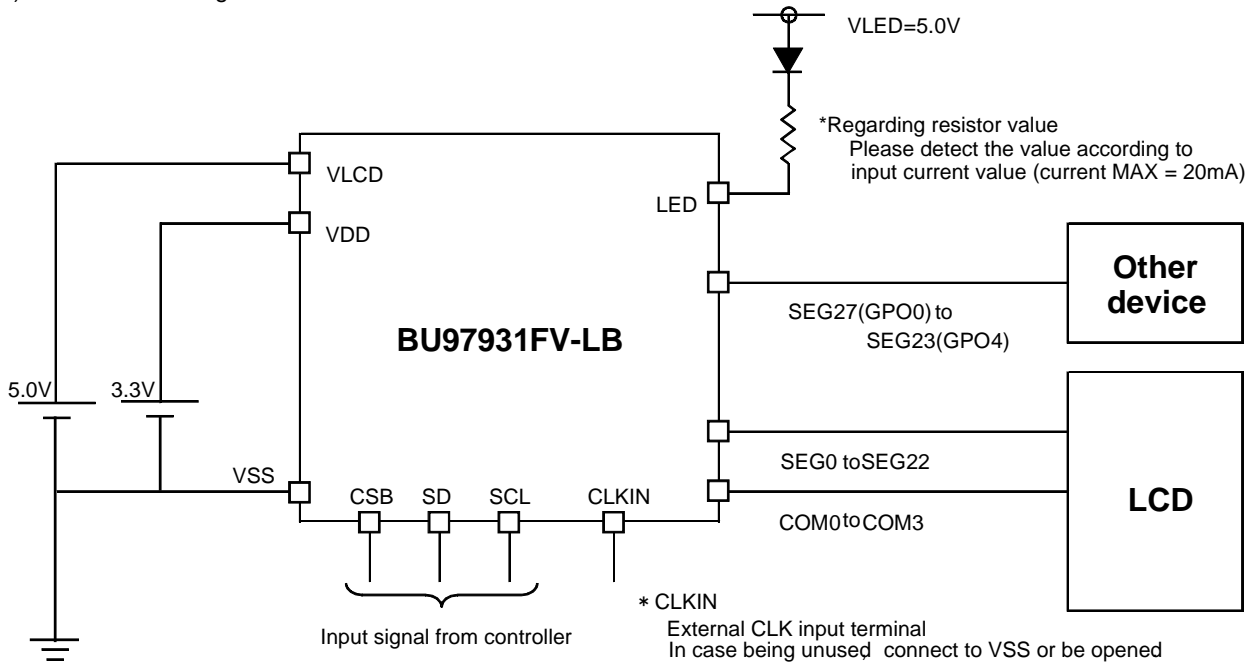

Figure 5. I/O Equivalence Circuit circuit

Example of recommended circuit

(1) LED/GPO using case



(2) SEG output only case

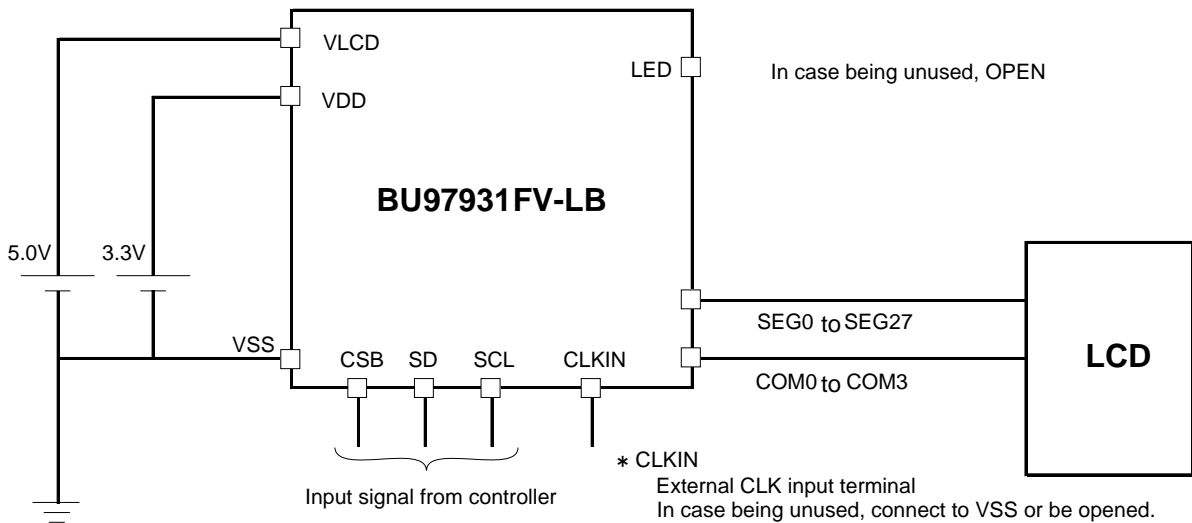

Figure 6. BU97931FV-LB E.g. of recommended circuit

Function description

Command and data transfer method

3-SPI (3-wire serial interface)

This device is controlled by a 3-wire signal (CSB, SCL, and SD).

First, Interface counter is initialized with CSB="H".

Setting CSB="L" enables SD and SCL inputs.

The protocol of 3-SPI transfer is as follows.

Each command starts with Command or Data judgment bit (D/C) as MSB data, followed by data D6 to D0 (this is when CSB="L").

(Internal data is latched at the rising edge of SCL then it is converted to an 8-bit parallel data at the falling edge of the 8th CLK.)

When CSB changes from "L" to "H", and at this time sending commands are less than 8 bits, command and data transfer are cancelled. To start sending command again, please set CSB="L" and send command continuously.

After sending RAMWR or BLKWR or GPOSET command, this device is in the RAM data input mode. Under this mode, device can not accept new commands.

In this case, please execute a "H" to "L" transition at CSB, after this sequence the device is released from RAM data input mode, and can accept new command.

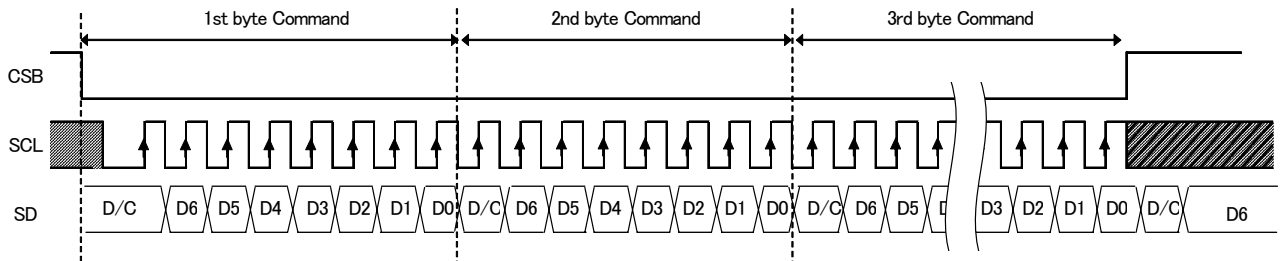
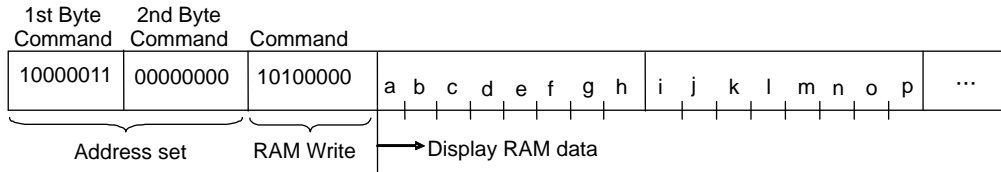

Figure 7. 3-SPI Data transfer Format

8-bit data sending after RAMWR command are display RAM data
 8-bit data sending after BLKWR command are blink RAM data
 SCL and SD can be set to "H" or cleared to "L" during CSB="H"

Write display data and transfer method

This device has Display Data RAM (DDRAM) of 28×4=112bit.
The relationship between data input and display data, DDRAM data and address are as follows.



According to this command, an 8-bit binary data will be written to DDRAM. The starting address of the DDRAM where data will be written is specified by "ADSET" command, and is automatically incremented after every 4 bits of data received.

Writing data to DDRAM can be done by continuously sending data.
(In case data is sent continuously after write date at 1Bh (SEG27), address return to address 00h (SEG0) automatically.)

In case SEG port assigned to GPO port by OUTSET command, corresponding SEG address do not change and is used as a dummy address.

		DDRAM address													
		00	01	02	03	04	05	06	07	...	19h	1Ah	1Bh		
BIT	0	a	e	i	m									COM0	
	1	b	f	j	n									COM1	
	2	c	g	k	o									COM2	
	3	d	h	l	p									COM3	
		SEG 0	SEG 1	SEG 2	SEG 3	SEG 4	SEG 5	SEG 6	SEG 7	...	SEG 25	SEG 26	SEG 27		

Display data write to DDRAM every 4bits.
In case CSB changes from "L" to "H" before 4 bits of data transfer was finished, RAM write is cancelled.

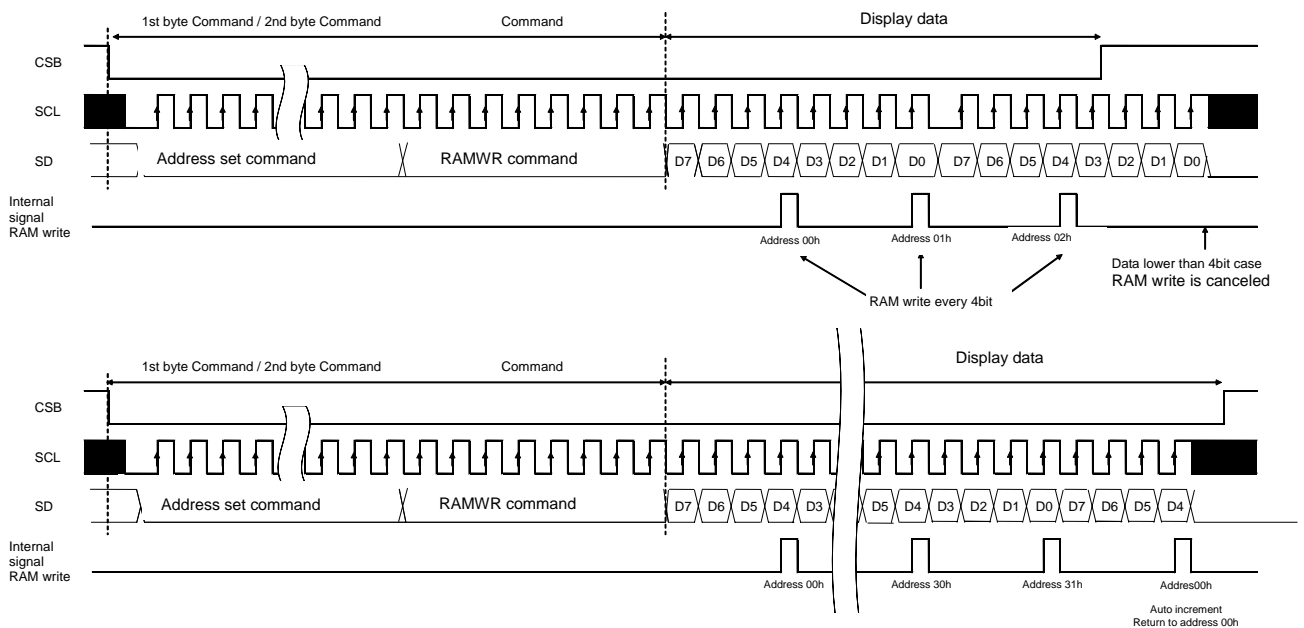

Figure 8. Display Data Transfer Method

Blink function

This device has Blink function. Blink function can set each segment port individually. Blink ON/OFF and Blink frequency are set by the BLKSET command. Blink frequency varies according to fCLK characteristics. Blink setup of each segment is controlled by BLKW command.

The write start address is specified by "BLKADSET" command. And this address will automatically increment after receiving every 4 bits of blink data. The relation of BLKW command, blink ram data, and blinking segment port is below.

In case data is "1", segment will blink, on the other hand when data is "0", segment will not blink. (In case data is written continuously after write data at 1Bh (SEG27), address will return to 00h (SEG0) automatically.)

Please refer to the following figures about Blink operation of each segment.

In case SEG port assigned to GPO port by OUTSET command, corresponding SEG address does not change and is used as a dummy address.

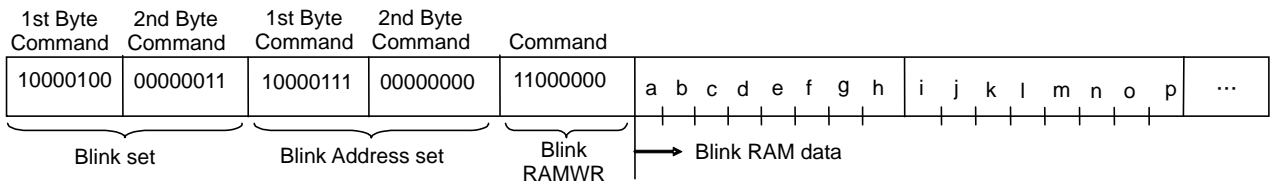

Blink RAM address

	00	01	02	03	04	05	06	07	...	19h	1Ah	1Bh	
0	a	e	i	m									COM0
1	b	f	j	n									COM1
2	c	g	k	o									COM2
3	d	h	l	p									COM3
	SEG 0	SEG 1	SEG 2	SEG 3	SEG 4	SEG 5	SEG 6	SEG 7	...	SEG 25	SEG 26	SEG 27	

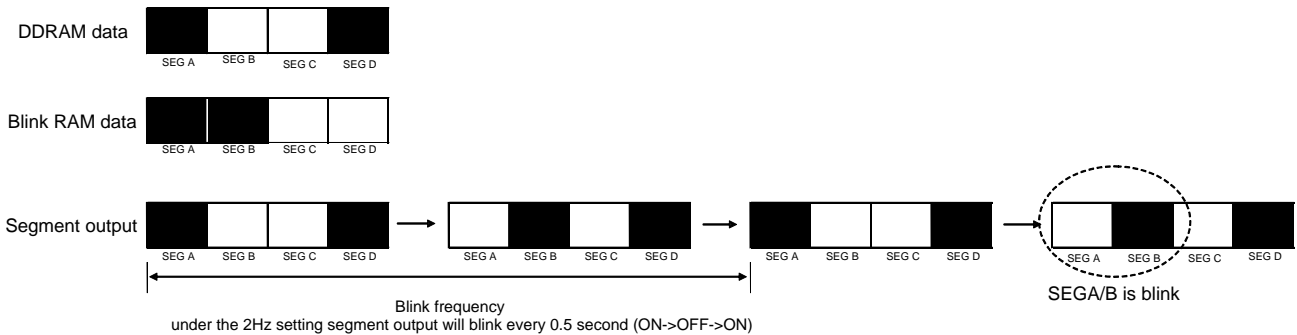

Figure 9. Blink Operation

LCD Driver Bias/Duty Circuit

BU97931FV-LB generates LCD driving voltage using an on-chip Buffer AMP.

Also, it can drive LCD with low power consumption

Line and frame inversion can be set in MODESET command.

1/4duty, 1/3duty and static mode can be set DISCTL command.

About each LCD driving waveform, please refer to "LCD driving waveform" descriptions.

Initial state

Initial state after SWRST command input

○Display off

○All command register values are in Reset state.

○DDRAM address data and Blink address data are initialized

(If DDRAM data and Blink RAM data are not initialized, write DDRAM data and Blink RAM data before Display on.)

Command / Function list

Function description table

NO	Command	Function
1	Mode Set (MODESET)	Sets LCD drive mode (display on/off, current mode)
2	Display control (DISCTL)	Sets LCD drive mode (frame freq., line/frame inversion)
3	Address set (ADSET)	Sets display data RAM address for RAMWR command
4	Blink set (BLKSET)	Sets Blink mode on/off
5	Blink address set (BLKADSET)	Sets Blink data RAM address for BLKWR command
6	SEG/GPO port change (OUTSET)	Selects segment output/general purpose output (GPO)
7	LED drive control (PWMSET) (H piece adjustment of PWM)	Sets PWM1 signal "H" width for LED driving
8	RAM WRITE (RAMWR)	Writes display data to display data RAM
9	Blink RAM WRITE (BLKWR)	Writes Blink data to BLINK data RAM
10	All Pixel ON (APON)	Sets all Pixel display on
11	All Pixel OFF (APOFF)	Sets all Pixel display off
12	All Pixel On/Off mode off (NORON)	Sets normal display mode (APON/APOFF cancel)
13	Software Reset (SWRST)	Software Reset
14	OSC external input (OSCSET)	Enables External clock input
15	GPO output set (GPOSET)	Sets GPO output data

Detailed Command Descriptions

D/C, Data / Command judgment bit (MSB)
For details, please refer to 3-wire serial I/F

1. Mode Set (MODESET)

	MSB					LSB				
	D/C	D6	D5	D4	D3	D2	D1	D0	Hex	Reset
1st byte command	1	0	0	0	0	0	0	1	81h	-
2nd byte command	0	0	0	0	P3	P2	P1	P0	-	00h

Display Set

Condition	P3	Reset state
Display OFF	0	○
Display ON	1	

Display OFF: No LCD driving mode (Output: VSS Level)

Turn off OSC circuit and LCD power supply circuit. (Synchronized with frame freq)

Display ON: LCD driving mode

Turn on OSC circuit and LCD power supply circuit.

Read data from DDRAM and display to LCD.

LED port and GPO port output states are not influenced by a Display on/off state

Output state is decided by command setup (OUTSET, GPOSET, PWMSET) and INHb terminal state, respectively.

For more details, please refer to each command description.

LCD drive mode set

Condition	P2	Reset state
Frame inversion	0	○
Line inversion	1	

Current mode set

Condition	P1	P0	Reset state
Power save mode1	0	0	○
Power save mode2	0	1	
Normal mode	1	0	
High power mode	1	1	

(Reference data of consumption current)

Condition	Current consumption
Power save mode 1	×1.0
Power save mode 2	×1.7
Normal mode	×2.7
High power mode	×5.0

(Note) The value changes according to the panel load.

2. Display control (DISCTL)

	MSB						LSB				Hex	Reset
	D/C	D6	D5	D4	D3	D2	D1	D0				
1st byte Command	1	0	0	0	0	0	1	0	82h	-		
2nd byte Command	0	0	0	0	P3	P2	P1	P0	-	02h		

Duty set

Condition	P3	P2	Reset state
1/4duty (1/3bias)	0	0	○
1/3duty (1/3bias)	0	1	
Static (1/1bias)	1	*	

*: Don't care

In 1/3duty, Display data and Blink data of COM3 are ineffective. COM1 and COM3 output are same data.

Please be careful in transmitting display data and blink data.

The examples of SEG/COM output waveform, under each Bias/Duty set up, are shown at "LCD Driver Bias/Duty Circuit" description.

Frame frequency set

Condition (1/4,1/3,1/1duty)	P1	P0	Reset state
(128Hz, 130Hz, 128Hz)	0	0	
(85Hz, 86Hz, 64Hz)	0	1	
(64Hz, 65Hz, 48Hz)	1	0	○
(51Hz, 52Hz, 32Hz)	1	1	

Relation table, between Frame frequencies (FR), integrated oscillator circuit (OSC) and Divide number.

DISCTL (P1,P0)	Divide			FR [Hz] ^(Note1)		
	Duty set (P3,P2)			Duty set (P3,P2)		
	(0,0) 1/4duty	(0,1) 1/3duty	(1,*) 1/1duty	(0,0) 1/4duty	(0,1) 1/3duty	(1,*) 1/1duty
(0,0)	160	156	160	128	131.3	128
(0,1)	240	237	320	85.3	86.4	64
(1,0)	320	315	428	64	65	47.9
(1,1)	400	393	640	51.2	52.1	32

(Note1) FR is frame frequency, in case OSC frequency = 20.48KHz (typ).

The Formula, to calculate OSC frequency from Frame frequency is shown below.

“ OSC frequency = Frame frequency (measurement value) x Divide number ”

Divide number determined by using the value of Frame Frequency Set (P1, P0) and duty setting (P3, P2).

Ex) (P1,P0) = (0,1) ,(P3,P2) = (0,1) => Divide number= 237

3. Address set (ADSET)

	MSB						LSB				Hex	Reset
	D/C	D6	D5	D4	D3	D2	D1	D0				
1st byte Command	1	0	0	0	0	0	1	1	83h	-		
2nd byte Command	0	0	0	P4	P3	P2	P1	P0	-	00h		

Sets start address to write DDRAM data.
 The address can be set from 00h to 1Bh.
 Do not set other address. (Except 00h to 1Bh address is not acceptable.)
 In case writing data to DDRAM, make sure to send RAMWR command.

4. Blink set (BLKSET)

	MSB						LSB				Hex	Reset
	D/C	D6	D5	D4	D3	D2	D1	D0				
1 st byte Command	1	0	0	0	0	1	0	0	84h	-		
2 nd byte Command	0	0	0	0	0	P2	P1	P0	-	00h		

Set Blink ON/OFF.
 For more details, please refer to "Blink function".

Blink set

Blink mode(Hz)	P2	P1	P0	Reset state
OFF	0	0 / *	0 / *	○
1.6	1	0	0	
2.0	1	0	1	
2.6	1	1	0	
4.0	1	1	1	

*: Don't care

5. Blink address set (BLKADSET)

	MSB						LSB				Hex	Reset
	D/C	D6	D5	D4	D3	D2	D1	D0				
1st byte Command	1	0	0	0	0	1	1	1	87h	-		
2nd byte Command	0	0	0	P4	P3	P2	P1	P0	-	00h		

Sets RAM start address to write Blink data.
 The address can be set from 00h to 1Bh.
 Do not set other addresses. (Except 00h to 1Bh address is not acceptable)
 In case writing data to Blink RAM, make sure to send BLKWR command.

6. SEG/GPO port change (OUTSET)

	MSB					LSB				
	D/C	D6	D5	D4	D3	D2	D1	D0	Hex	Reset
1st byte Command	1	0	0	0	1	0	0	0	88h	-
2nd byte Command	0	0	0	0	0	P2	P1	P0	-	00h

Set output mode, Segment output or GPO output.

P2 to P0: Select changing port number. (SEG23 to SEG27 ports are SEG mode/GPO mode selectable)

In case GPO output is selected, terminal output data is set by GPOSET command.

Ex) In case SEG 26 port is assigned to GPO,

If GPO1 data is "H", GPO1 (SEG26) port outputs "H" (VLCD Level).

If GPO1 data is "L", GPO1 (SEG26) port outputs "L" (VSS level).

Output terminal state under the P2 to P0 set condition is listed below.

Output Terminal state

Condition			SEG Terminal state (SEG output/GPO output)				
P2	P1	P0	SEG23 port	SEG24 port	SEG25 port	SEG26 port	SEG27 port
0	0	0	SEG23	SEG24	SEG25	SEG26	SEG27
0	0	1	SEG23	SEG24	SEG25	SEG26	GPO0
0	1	0	SEG23	SEG24	SEG25	GPO1	GPO0
0	1	1	SEG23	SEG24	GPO2	GPO1	GPO0
1	0	0	SEG23	GPO3	GPO2	GPO1	GPO0
1	0	1	GPO4	GPO3	GPO2	GPO1	GPO0
1	1	*	(OUTSET command will be canceled)				

In case the SEG port is switched to the GPO port, DDRAM address and Blink RAM address do not change.

In case DDRAM address and Blink RAM address, selected GPO output mode is dummy address.

7. LED drive-control (PWM “H” width control) command (PWMSET)

	MSB						LSB				
	D/C	D6	D5	D4	D3	D2	D1	D0	Hex	Reset	
1st byte Command	1	0	0	0	1	0	1	0	8Ah	-	
2nd byte Command	0	0	0	0	0	0	P7	P6	-	00h	
3rd byte Command	0	0	P5	P4	P3	P2	P1	P0	-	00h	

2nd and 3rd byte command data can be set from 00h to 3Fh (described as 8-bit binary data).
 In case other value is selected, sending command is ignored and 2nd and 3rd byte command data are set to 3Fh.
 In reset state, 2nd and 3rd byte command data are set to 00h.
 In case the command is less than 3 byte, sending command is cancelled.

According to PWMSET command, LED driving signal is adjustable. PWM “H” width is adjustable by 8-bit resolution.

Explanation about P7 to P6 data of 2nd byte command and P5 to P0 data of 3rd byte command are as follows:
 (The 2nd byte data are used as upper 2bit, and 3rd byte data are used as lower 6 bits.)

8bit mode: P7 data is used as MSB of 8 bits, and P0 data is used LSB.

LED driving period is determined by the “H” width of PWM signal, generated by PWM generator circuit (resolution: 8bit).

Ex)

In case external PWM clock is 125 KHz, parameter setting value is 127 (7Fh)
 1-bit resolution: 8us
 ALL HI set: PWM signal frequency about 500Hz, H width about 2.00msec
 ALL LOW set: PWM signal frequency about 500Hz, H width 0usec (in case 8bit resolution)

This command is reflected, synchronizing with a next PWM frame head.
 And, LED port output is as follows. LED port operation does not affect Display ON/OFF state.

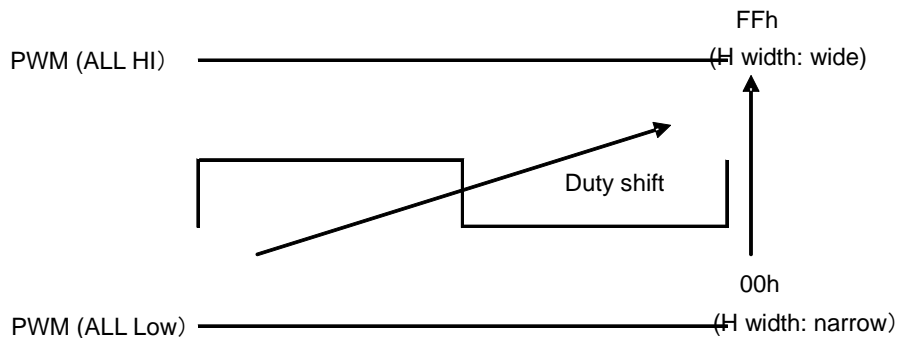

(Note) PWM frequency and PWM “H” width calculation

PWM cycle and PWM “H” width, decided by PWM clock cycle are described as follows.
 (PWM clock cycle is a minimum unit of PWM “H” width)

$$\begin{aligned} \text{PWM frequency} &= \text{PWM clock cycle} \times (\text{Number of the steps (8bit =256)} - 1) \\ \text{PWM H width} &= \text{PWM clock cycle} \times \text{Parameter set value (8bit: 0 to 255)} \\ \text{PWM Duty} &= \text{PWM H width} / \text{PWM cycle} = \text{Parameter set value} / \text{Number of the steps} \end{aligned}$$

In case PWM is generated from the internal clock, the PWM cycle varies depending on the OSC frequency.

In case LED is used as back light of LCD panel and PWM is generated from internal clock, there is a possibility that the display will flicker. For such cases, please use under the PWM width ALL “L” or ALL “H” setting only.

8. RAM WRITE (RAMWR)

	MSB							LSB			
	D/C	D6	D5	D4	D3	D2	D1	D0	Hex	Reset	
1st byte Command	1	0	1	0	0	0	0	0	A0h	-	
2nd byte Command	Display data									Random	
										
n byte Command	Display data									Random	

Input data, sending after 1st byte command, are used as Display data. And display data are sent every 4 bits. Please set this command after the ADSET command.

9. Blink RAM WRITE (BLKWR)

	MSB							LSB			
	D/C	D6	D5	D4	D3	D2	D1	D0	Hex	Reset	
1st byte Command	1	1	0	0	0	0	0	0	C0h	-	
2nd byte Command	Blink data									Random	
										
n byte Command	Blink data									Random	

Input data, sending after 1st byte command, are used as Display data. And display data are sent every 4 bits. Please set this command after the BLKADSET command.

10. All Pixel ON (APON)

	MSB							LSB			
	D/C	D6	D5	D4	D3	D2	D1	D0	Hex	Reset	
1st byte Command	1	0	0	1	0	0	0	1	91h	-	

After sending the command, all SEG outputs set display on state regardless of the DDRAM data. (This command affect to the SEG output terminal only except GPO and LED output.)

11. All Pixel OFF (APOFF)

	MSB							LSB			
	D/C	D6	D5	D4	D3	D2	D1	D0	Hex	Reset	
1st byte Command	1	0	0	1	0	0	0	0	90h	-	

After sending the command, all SEG outputs set display off state regardless of the DDRAM data. (This command affects the SEG output terminals only except GPO and LED outputs.)

12. All Pixel ON/OFF mode off (NORON)

	MSB							LSB			
	D/C	D6	D5	D4	D3	D2	D1	D0	Hex	Reset	
1st byte Command	1	0	0	1	0	0	1	1	93h	-	

After sending the command, all SEG outputs are released from APON/APOFF state. And SEG port outputs signal follows DDRAM data. (This command affects the SEG output terminals only except GPO and LED output.) After reset sequence or SWRESET, all outputs are set to NORON state.

13. Software Reset (SWRST)

	MSB							LSB			
	D/C	D6	D5	D4	D3	D2	D1	D0	Hex	Reset	
1st byte Command	1	0	0	1	0	0	1	0	92h	-	

After sending the command, device is set to the default state.

14. OSC external input command (OSCSET)

	MSB					LSB				Hex	Reset
	D/C	D6	D5	D4	D3	D2	D1	D0			
1st byte Command	1	0	0	1	1	0	0	0	98h	-	
2nd byte Command	0	0	0	0	0	P2	P1	P0	-	00h	

Sets the type of clock mode. There are 4 selectable modes including external clock input mode. Details of this command function are as follows.

Condition	P2	P1	P0	Reset state
Internal CLK (PWM generation OFF)	0	0	0	○
External CLK input for PWM (PWM generation OFF)	0	0	1	
Internal CLK (PWM generation ON)	0	1	0	
External CLK input for PWM (PWM generation ON)	0	1	1	
External CLK input for Display (ROHM use only)	1	*	*	

(*: Don't care)

(P2, P1, P0) = (0, 0, 1): External PWM input mode
 CLKIN: external PWM input available.
 PWMOUT: "L" Output
 (Note) under the (P2, P1, P0) = (0, 0, 0) condition PWMOUT into same state

(P2, P1, P0) = (0, 1, 0): PWM is generated from an internal oscillating frequency

(P2, P1, P0) = (0, 1, 1): PWM is generated from an External CLK input from CLKIN
 PWM width is set up by PWMSET and PWMSET command.

In case LED is used as back light of LCD panel and PWM is generated from internal clock, display flickering will occur. In this case, please use under the PWM width ALL "L" or ALL "H" setting only.

The relation of OSC function control by each command is as follows:

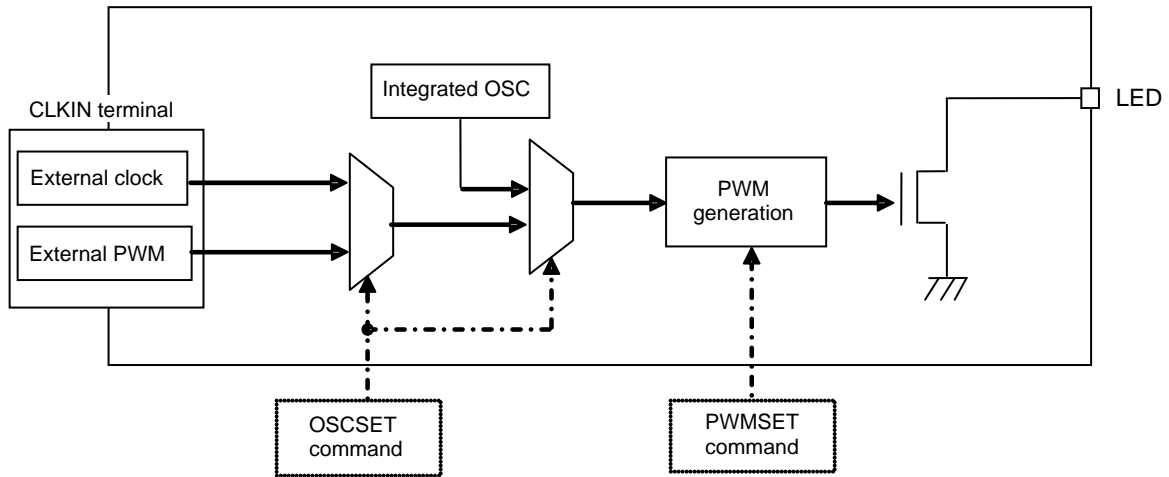

Figure 10. OSC External Input

15. GPO output set command (GPOSET)

	MSB				LSB				Hex	Reset
	D/C	D6	D5	D4	D3	D2	D1	D0		
1st byte Command	1	0	0	1	1	0	1	0	9Ah	-
2nd byte Command	0	0	0	P4	P3	P2	P1	P0	-	00h

Set GPO output data. The relation between SEG port (GPO port) and data is shown below.

GPOSET data	GPO port	SEG port
P0	GPO0	SEG27
P1	GPO1	SEG26
P2	GPO2	SEG25
P3	GPO3	SEG24
P4	GPO4	SEG23

GPO data output is asynchronous from frame cycle.

In case INHb="H", GPO output signal follows GPOSET data, on the other hand, in case INHb="L" GPO output is at GND level. GPO output is not affected by Display ON/OFF state.

LCD driving waveform

1/4Duty

Line inversion

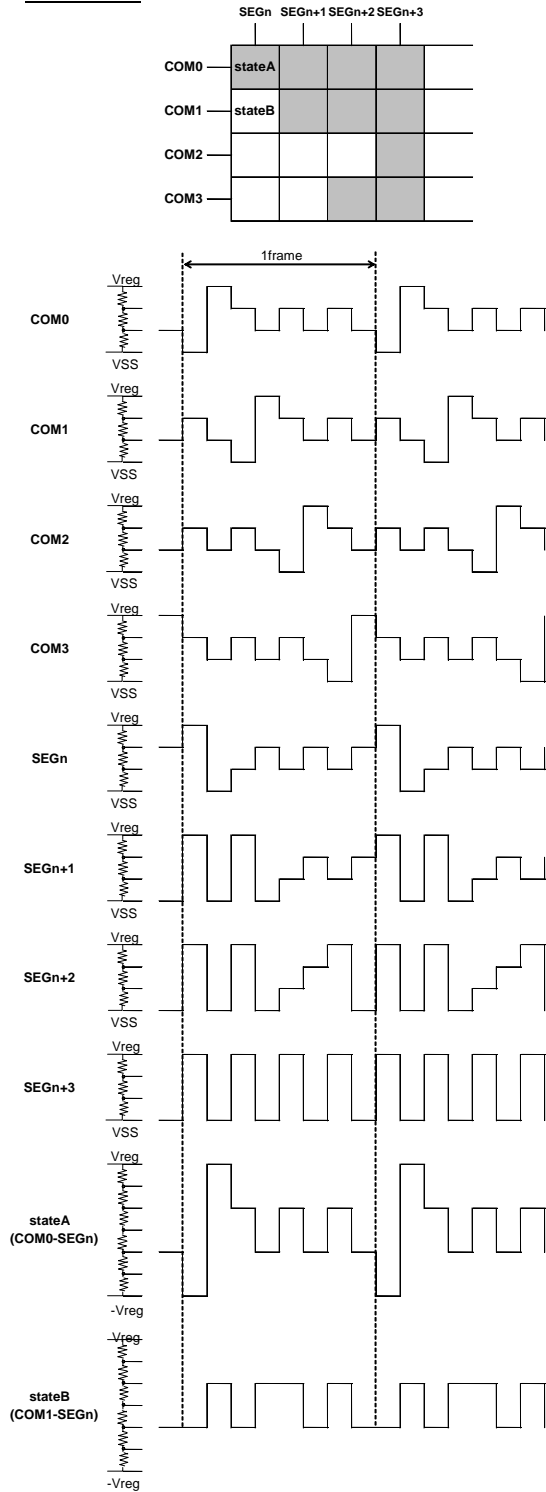

Figure 11. Waveform of Line Inversion

Frame inversion

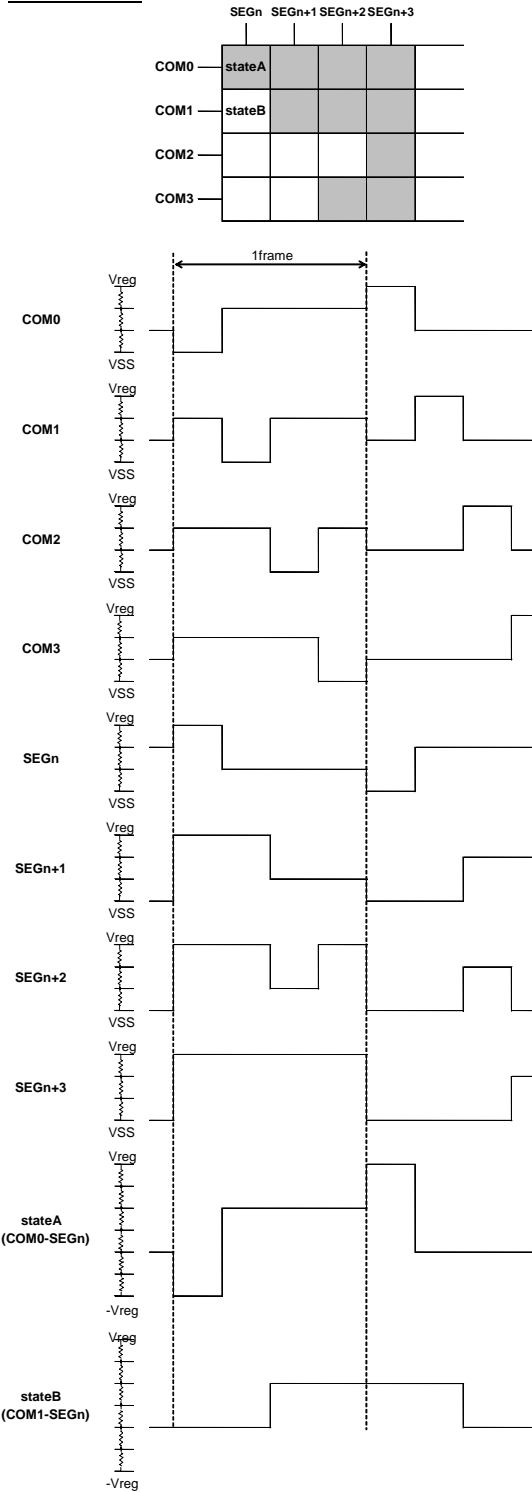

Figure 12. Waveform of Frame Inversion

1/3Duty

Line inversion

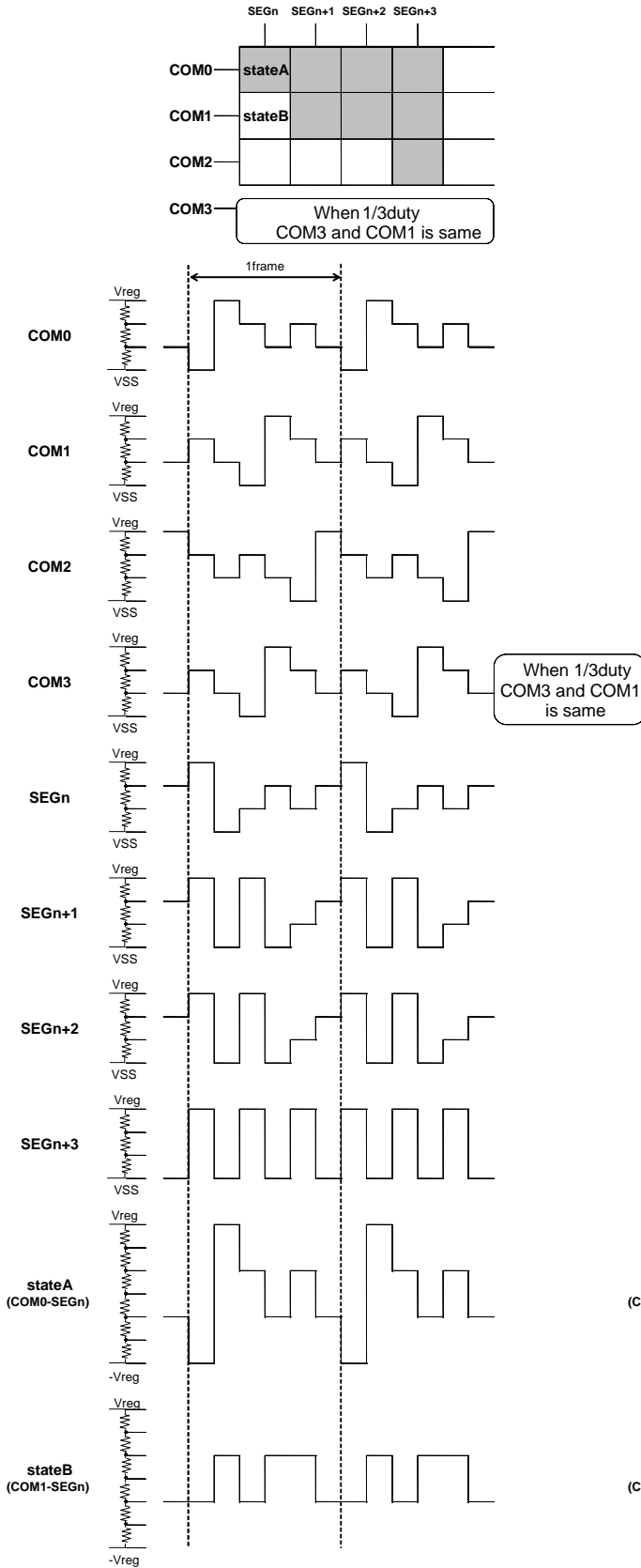

Figure 13. Waveform of Line Inversion

Frame inversion

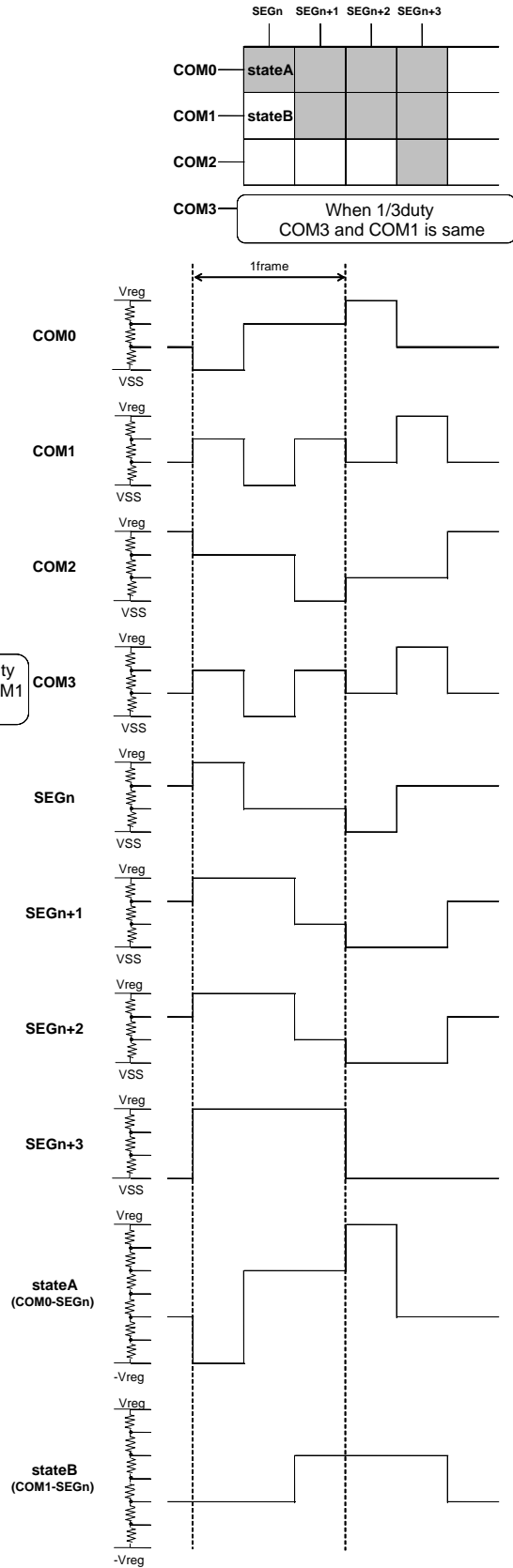

Figure 14. Waveform of Frame Inversion

1/1Duty (Static)

Line inversion

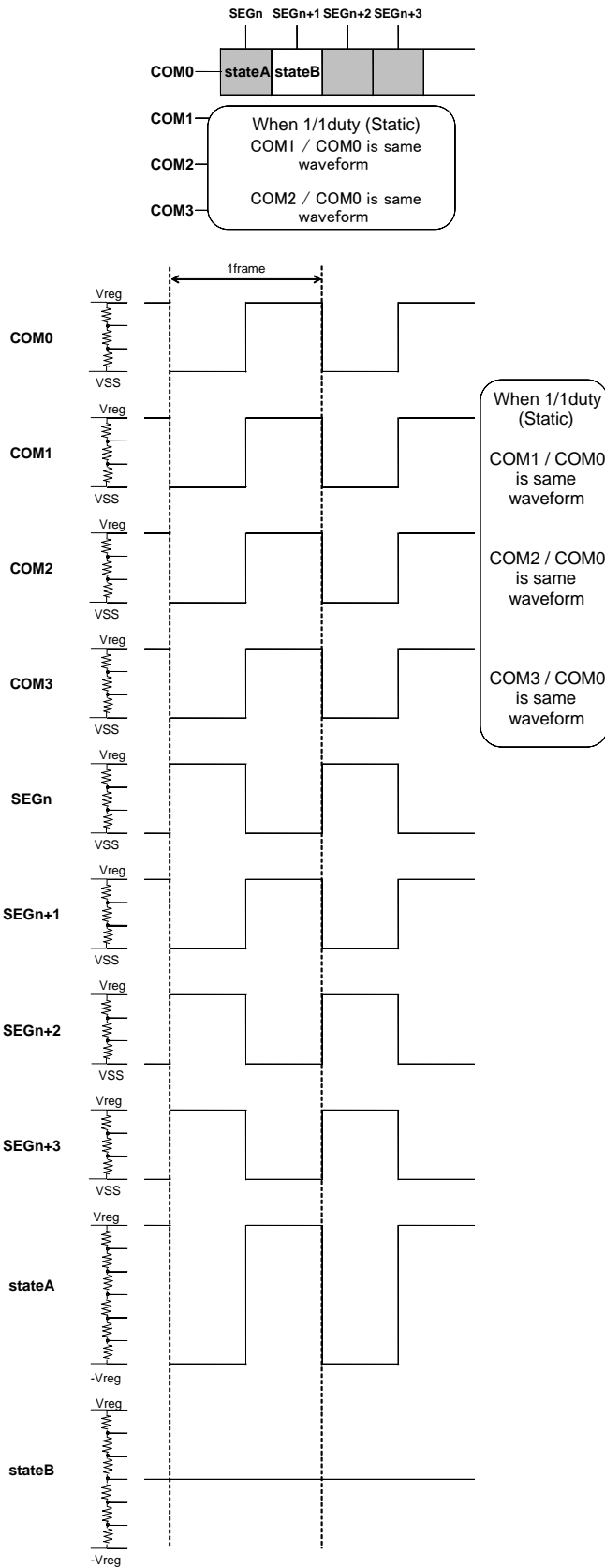

Figure 15. Waveform of Line Inversion

Frame inversion

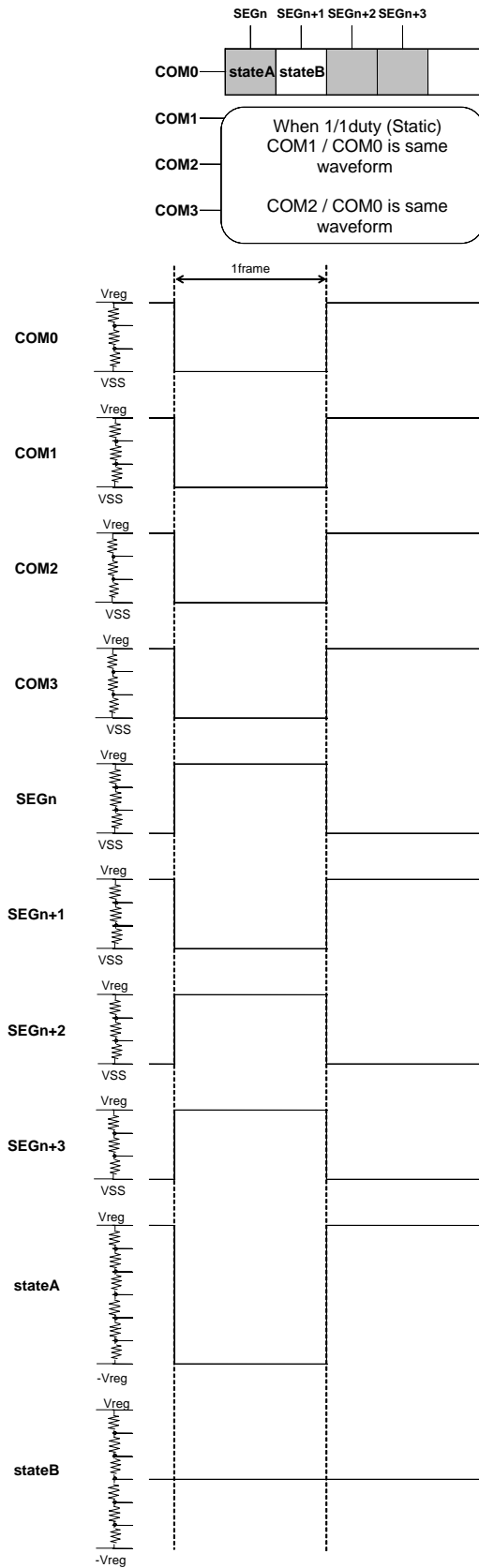
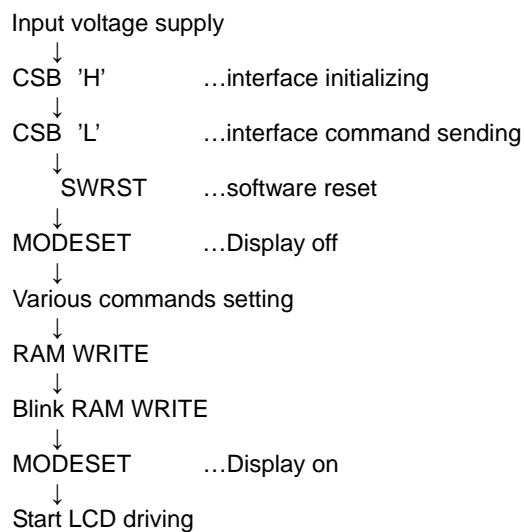

Figure 16. Waveform of Frame Inversion

Initialize Sequence

Recommended input sequence is listed below, before starting LCD driving.
(Refer to Power ON/OFF sequence)



Before initializing sequence, DDRAM address, DDRAM data, Blink address and Blink data are random.

Cautions on Power-On/ Power-Off condition

POR circuit

BU97931FV-LB has "P.O.R" (Power-On Reset) circuit and Software Reset function.

Please follow the recommended Power-On conditions in order to power up properly.

(1) Please set power up conditions, follow the recommended t_R , t_F , t_{OFF} , and V_{bot} specification below in order to ensure P.O.R operation.

(*The detection voltage of POR varies because of environment etc. To operate POR properly, please satisfy V_{bot} lower than 0.5V condition.)

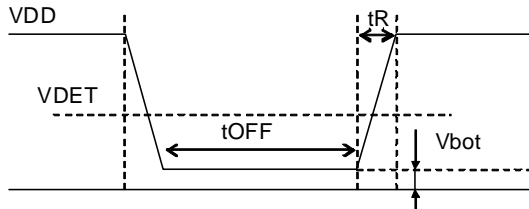

Recommended condition of t_R , t_F , t_{OFF} , V_{bot}

t_R	t_{OFF}	V_{bot}	VDET
less than 10ms	Over 1ms	less than 0.5V	TYP 1.2V

* VDET : POR detect level

Figure 17. Power ON/OFF Waveform

(2) If it is difficult to meet the above conditions, execute the following sequence after Power-On.

- (1) CSB="L"→"H" condition
- (2) After CSB"H"→"L", execute SWRST command

In addition, in order to the Software reset command certainly, please wait 1ms after a VDD level reaches to 90% and CSB="L"→"H".

*Before SWRST command input device will be in unstable state, since SWRST command does not operate perfect substitution of a POR function.

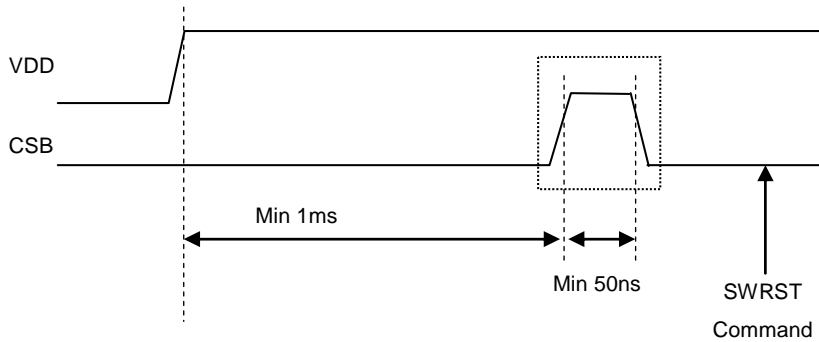

Figure 18. SWRST Command Sequence

Attention about input port pull down

Satisfy the following sequence if input terminals are pulled down by external resistors (In case MPU output Hi-Z).

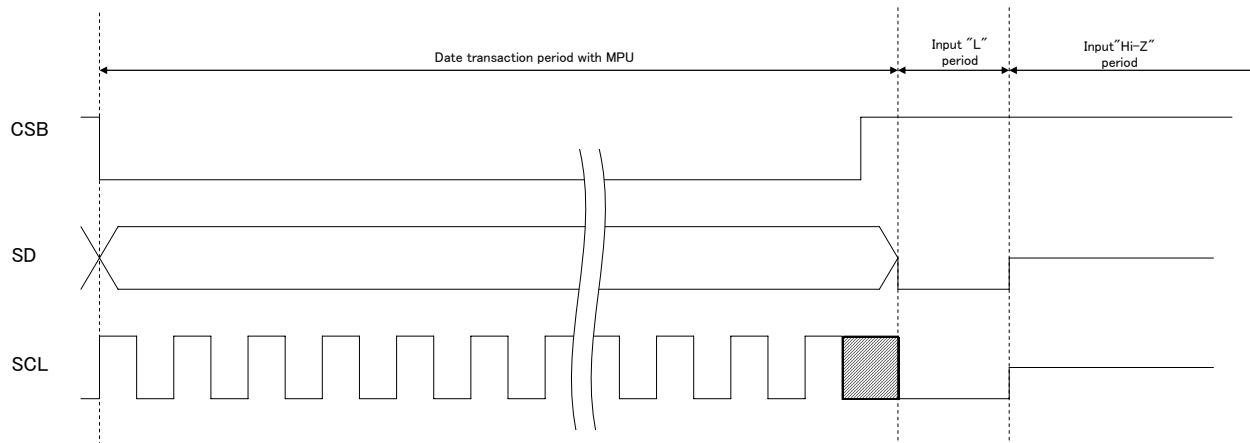

Figure 19. Recommended Sequence when Input Ports are Pulled Down

BU97931FUV-LB adopts a 5V tolerant I/O for the digital input. This circuit includes a bus-hold function to keep HIGH level. A pull down resistor of below 10K Ω shall be connected to the input terminals for transitions from HIGH to LOW because the bus-hold transistor turns on during the input's HIGH level. (Refer to the Figure 5; I/O Equivalent Circuit)

A higher resistor than 10K Ω (approximate) causes input terminals being steady by intermediate potential between HIGH and LOW level so unexpected current is consumed by the system.

The potential depends on the pull down resistance and bus-hold transistor's resistance.

As the bus-hold transistor turns off upon the input level is cleared to LOW, a higher resistor can be used as a pull down resistor if MPU sets SD and SCL lines to LOW before it releases the lines.

The LOW period preceding MPU's bus release shall be at least 50ns as same as a minimum CLK width (tSLW).

Operational Notes

1. Reverse Connection of Power Supply

Connecting the power supply in reverse polarity can damage the IC. Take precautions against reverse polarity when connecting the power supply, such as mounting an external diode between the power supply and the IC's power supply pins.

2. Power Supply Lines

Design the PCB layout pattern to provide low impedance supply lines. Separate the ground and supply lines of the digital and analog blocks to prevent noise in the ground and supply lines of the digital block from affecting the analog block. Furthermore, connect a capacitor to ground at all power supply pins. Consider the effect of temperature and aging on the capacitance value when using electrolytic capacitors.

3. Ground Voltage

Ensure that no pins are at a voltage below that of the ground pin at any time, even during transient condition.

4. Ground Wiring Pattern

When using both small-signal and large-current ground traces, the two ground traces should be routed separately but connected to a single ground at the reference point of the application board to avoid fluctuations in the small-signal ground caused by large currents. Also ensure that the ground traces of external components do not cause variations on the ground voltage. The ground lines must be as short and thick as possible to reduce line impedance.

5. Thermal Consideration

Should by any chance the power dissipation rating be exceeded the rise in temperature of the chip may result in deterioration of the properties of the chip. The absolute maximum rating of the Pd stated in this specification is when the IC is mounted on a 70mm x 70mm x 1.6mm glass epoxy board. In case of exceeding this absolute maximum rating, increase the board size and copper area to prevent exceeding the Pd rating.

6. Recommended Operating Conditions

These conditions represent a range within which the expected characteristics of the IC can be approximately obtained. The electrical characteristics are guaranteed under the conditions of each parameter.

7. Inrush Current

When power is first supplied to the IC, it is possible that the internal logic may be unstable and inrush current may flow instantaneously due to the internal powering sequence and delays, especially if the IC has more than one power supply. Therefore, give special consideration to power coupling capacitance, power wiring, width of ground wiring, and routing of connections.

8. Operation Under Strong Electromagnetic Field

Operating the IC in the presence of a strong electromagnetic field may cause the IC to malfunction.

9. Testing on Application Boards

When testing the IC on an application board, connecting a capacitor directly to a low-impedance output pin may subject the IC to stress. Always discharge capacitors completely after each process or step. The IC's power supply should always be turned off completely before connecting or removing it from the test setup during the inspection process. To prevent damage from static discharge, ground the IC during assembly and use similar precautions during transport and storage.

10. Inter-pin Short and Mounting Errors

Ensure that the direction and position are correct when mounting the IC on the PCB. Incorrect mounting may result in damaging the IC. Avoid nearby pins being shorted to each other especially to ground, power supply and output pin. Inter-pin shorts could be due to many reasons such as metal particles, water droplets (in very humid environment) and unintentional solder bridge deposited in between pins during assembly to name a few.

Operational Notes – continued**11. Unused Input Pins**

Input pins of an IC are often connected to the gate of a MOS transistor. The gate has extremely high impedance and extremely low capacitance. If left unconnected, the electric field from the outside can easily charge it. The small charge acquired in this way is enough to produce a significant effect on the conduction through the transistor and cause unexpected operation of the IC. So unless otherwise specified, unused input pins should be connected to the power supply or ground line.

12. Regarding the Input Pin of the IC

In the construction of this IC, P-N junctions are inevitably formed creating parasitic diodes or transistors. The operation of these parasitic elements can result in mutual interference among circuits, operational faults, or physical damage. Therefore, conditions which cause these parasitic elements to operate, such as applying a voltage to an input pin lower than the ground voltage should be avoided. Furthermore, do not apply a voltage to the input pins when no power supply voltage is applied to the IC. Even if the power supply voltage is applied, make sure that the input pins have voltages within the values specified in the electrical characteristics of this IC.

13. Ceramic Capacitor

When using a ceramic capacitor, determine the dielectric constant considering the change of capacitance with temperature and the decrease in nominal capacitance due to DC bias and others.

14. Area of Safe Operation (ASO)

Operate the IC such that the output voltage, output current, and power dissipation are all within the Area of Safe Operation (ASO).

15. Thermal Shutdown Circuit(TSD)

This IC has a built-in thermal shutdown circuit that prevents heat damage to the IC. Normal operation should always be within the IC's power dissipation rating. If however the rating is exceeded for a continued period, the junction temperature (T_j) will rise which will activate the TSD circuit that will turn OFF all output pins. When the T_j falls below the TSD threshold, the circuits are automatically restored to normal operation.

Note that the TSD circuit operates in a situation that exceeds the absolute maximum ratings and therefore, under no circumstances, should the TSD circuit be used in a set design or for any purpose other than protecting the IC from heat damage.

16. Over Current Protection Circuit (OCP)

This IC incorporates an integrated overcurrent protection circuit that is activated when the load is shorted. This protection circuit is effective in preventing damage due to sudden and unexpected incidents. However, the IC should not be used in applications characterized by continuous operation or transitioning of the protection circuit.

Ordering Information

B U 9 7 9 3 1 F V		-	L B E 2
Part Number	Package FV : SSOP-B40		Products Class LB for Industrial applications Packaging and forming specification E2: Embossed tape and reel (SSOP-B40)

Marking Diagram

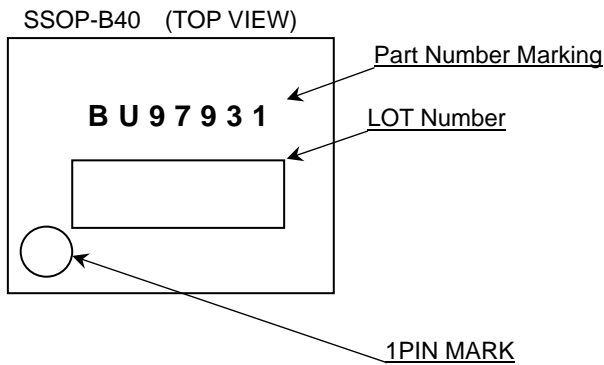

Physical Dimension, Tape and Reel Information

Package Name	SSOP-B40
--------------	----------

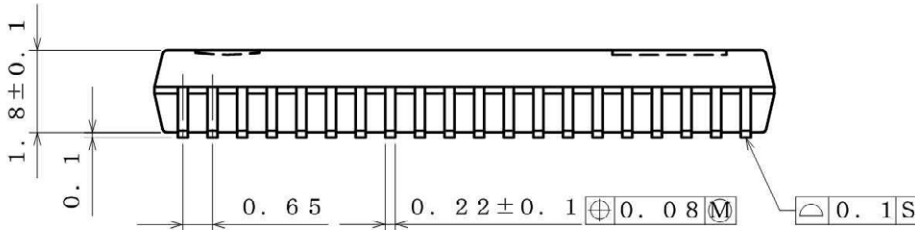
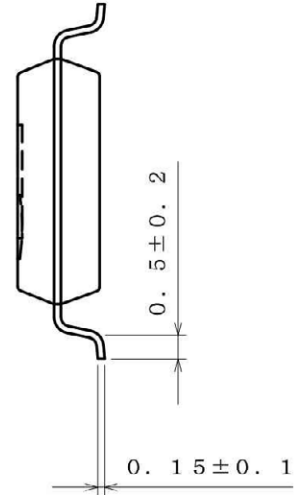
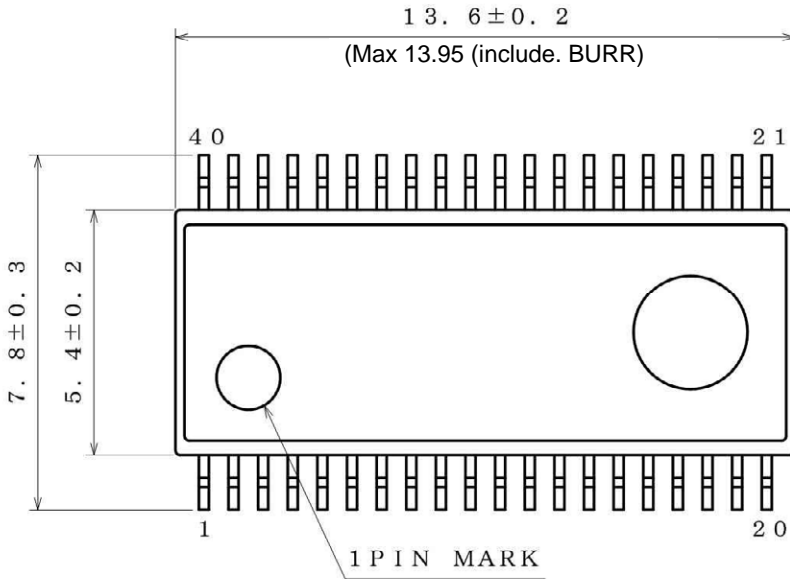

(UNIT ; mm)

PKG : SSOP-B40

図番 ; EX157-5001

<Tape and Reel information>

Tape	Embossed carrier tape
Quantity	2000pcs
Direction of feed	E2 (The direction is the 1pin of product is at the upper left when you hold reel on the left hand and you pull out the tape on the right hand)

Reel

1pin

Direction of feed

*Order quantity needs to be multiple of the minimum quantity.

Revision History

Date	Revision	Changes
23.Aug.2013	001	New Release
26.Feb.2014	002	Delete sentence "and log life cycle" in General Description and Futures. Applied new style (change of the size of the title).

Notice

Precaution on using ROHM Products

1. If you intend to use our Products in devices requiring extremely high reliability (such as medical equipment ^(Note 1), aircraft/spacecraft, nuclear power controllers, etc.) and whose malfunction or failure may cause loss of human life, bodily injury or serious damage to property ("Specific Applications"), please consult with the ROHM sales representative in advance. Unless otherwise agreed in writing by ROHM in advance, ROHM shall not be in any way responsible or liable for any damages, expenses or losses incurred by you or third parties arising from the use of any ROHM's Products for Specific Applications.

(Note1) Medical Equipment Classification of the Specific Applications

JAPAN	USA	EU	CHINA
CLASS III	CLASS III	CLASS II b	CLASS III
CLASS IV		CLASS III	

2. ROHM designs and manufactures its Products subject to strict quality control system. However, semiconductor products can fail or malfunction at a certain rate. Please be sure to implement, at your own responsibilities, adequate safety measures including but not limited to fail-safe design against the physical injury, damage to any property, which a failure or malfunction of our Products may cause. The following are examples of safety measures:
 - [a] Installation of protection circuits or other protective devices to improve system safety
 - [b] Installation of redundant circuits to reduce the impact of single or multiple circuit failure
3. Our Products are not designed under any special or extraordinary environments or conditions, as exemplified below. Accordingly, ROHM shall not be in any way responsible or liable for any damages, expenses or losses arising from the use of any ROHM's Products under any special or extraordinary environments or conditions. If you intend to use our Products under any special or extraordinary environments or conditions (as exemplified below), your independent verification and confirmation of product performance, reliability, etc, prior to use, must be necessary:
 - [a] Use of our Products in any types of liquid, including water, oils, chemicals, and organic solvents
 - [b] Use of our Products outdoors or in places where the Products are exposed to direct sunlight or dust
 - [c] Use of our Products in places where the Products are exposed to sea wind or corrosive gases, including Cl₂, H₂S, NH₃, SO₂, and NO₂
 - [d] Use of our Products in places where the Products are exposed to static electricity or electromagnetic waves
 - [e] Use of our Products in proximity to heat-producing components, plastic cords, or other flammable items
 - [f] Sealing or coating our Products with resin or other coating materials
 - [g] Use of our Products without cleaning residue of flux (even if you use no-clean type fluxes, cleaning residue of flux is recommended); or Washing our Products by using water or water-soluble cleaning agents for cleaning residue after soldering
 - [h] Use of the Products in places subject to dew condensation
4. The Products are not subject to radiation-proof design.
5. Please verify and confirm characteristics of the final or mounted products in using the Products.
6. In particular, if a transient load (a large amount of load applied in a short period of time, such as pulse. is applied, confirmation of performance characteristics after on-board mounting is strongly recommended. Avoid applying power exceeding normal rated power; exceeding the power rating under steady-state loading condition may negatively affect product performance and reliability.
7. De-rate Power Dissipation (Pd) depending on Ambient temperature (Ta). When used in sealed area, confirm the actual ambient temperature.
8. Confirm that operation temperature is within the specified range described in the product specification.
9. ROHM shall not be in any way responsible or liable for failure induced under deviant condition from what is defined in this document.

Precaution for Mounting / Circuit board design

1. When a highly active halogenous (chlorine, bromine, etc.) flux is used, the residue of flux may negatively affect product performance and reliability.
2. In principle, the reflow soldering method must be used; if flow soldering method is preferred, please consult with the ROHM representative in advance.

For details, please refer to ROHM Mounting specification

Precautions Regarding Application Examples and External Circuits

1. If change is made to the constant of an external circuit, please allow a sufficient margin considering variations of the characteristics of the Products and external components, including transient characteristics, as well as static characteristics.
2. You agree that application notes, reference designs, and associated data and information contained in this document are presented only as guidance for Products use. Therefore, in case you use such information, you are solely responsible for it and you must exercise your own independent verification and judgment in the use of such information contained in this document. ROHM shall not be in any way responsible or liable for any damages, expenses or losses incurred by you or third parties arising from the use of such information.

Precaution for Electrostatic

This Product is electrostatic sensitive product, which may be damaged due to electrostatic discharge. Please take proper caution in your manufacturing process and storage so that voltage exceeding the Products maximum rating will not be applied to Products. Please take special care under dry condition (e.g. Grounding of human body / equipment / solder iron, isolation from charged objects, setting of ionizer, friction prevention and temperature / humidity control).

Precaution for Storage / Transportation

1. Product performance and soldered connections may deteriorate if the Products are stored in the places where:
 - [a] the Products are exposed to sea winds or corrosive gases, including Cl₂, H₂S, NH₃, SO₂, and NO₂
 - [b] the temperature or humidity exceeds those recommended by ROHM
 - [c] the Products are exposed to direct sunshine or condensation
 - [d] the Products are exposed to high Electrostatic
2. Even under ROHM recommended storage condition, solderability of products out of recommended storage time period may be degraded. It is strongly recommended to confirm solderability before using Products of which storage time is exceeding the recommended storage time period.
3. Store / transport cartons in the correct direction, which is indicated on a carton with a symbol. Otherwise bent leads may occur due to excessive stress applied when dropping of a carton.
4. Use Products within the specified time after opening a humidity barrier bag. Baking is required before using Products of which storage time is exceeding the recommended storage time period.

Precaution for Product Label

QR code printed on ROHM Products label is for ROHM's internal use only.

Precaution for Disposition

When disposing Products please dispose them properly using an authorized industry waste company.

Precaution for Foreign Exchange and Foreign Trade act

Since our Products might fall under controlled goods prescribed by the applicable foreign exchange and foreign trade act, please consult with ROHM representative in case of export.

Precaution Regarding Intellectual Property Rights

1. All information and data including but not limited to application example contained in this document is for reference only. ROHM does not warrant that foregoing information or data will not infringe any intellectual property rights or any other rights of any third party regarding such information or data. ROHM shall not be in any way responsible or liable for infringement of any intellectual property rights or other damages arising from use of such information or data.:
2. No license, expressly or implied, is granted hereby under any intellectual property rights or other rights of ROHM or any third parties with respect to the information contained in this document.

Other Precaution

1. This document may not be reprinted or reproduced, in whole or in part, without prior written consent of ROHM.
2. The Products may not be disassembled, converted, modified, reproduced or otherwise changed without prior written consent of ROHM.
3. In no event shall you use in any way whatsoever the Products and the related technical information contained in the Products or this document for any military purposes, including but not limited to, the development of mass-destruction weapons.
4. The proper names of companies or products described in this document are trademarks or registered trademarks of ROHM, its affiliated companies or third parties.

General Precaution

1. Before you use our Products, you are requested to carefully read this document and fully understand its contents. ROHM shall not be in any way responsible or liable for failure, malfunction or accident arising from the use of any ROHM's Products against warning, caution or note contained in this document.
2. All information contained in this document is current as of the issuing date and subject to change without any prior notice. Before purchasing or using ROHM's Products, please confirm the latest information with a ROHM sales representative.
3. The information contained in this document is provided on an "as is" basis and ROHM does not warrant that all information contained in this document is accurate and/or error-free. ROHM shall not be in any way responsible or liable for any damages, expenses or losses incurred by you or third parties resulting from inaccuracy or errors of or concerning such information.



**Стандарт
Электрон
Связь**

Мы молодая и активно развивающаяся компания в области поставок электронных компонентов. Мы поставляем электронные компоненты отечественного и импортного производства напрямую от производителей и с крупнейших складов мира.

Благодаря сотрудничеству с мировыми поставщиками мы осуществляем комплексные и плановые поставки широчайшего спектра электронных компонентов.

Собственная эффективная логистика и склад в обеспечивает надежную поставку продукции в точно указанные сроки по всей России.

Мы осуществляем техническую поддержку нашим клиентам и предпродажную проверку качества продукции. На все поставляемые продукты мы предоставляем гарантию .

Осуществляем поставки продукции под контролем ВП МО РФ на предприятия военно-промышленного комплекса России , а также работаем в рамках 275 ФЗ с открытием отдельных счетов в уполномоченном банке. Система менеджмента качества компании соответствует требованиям ГОСТ ISO 9001.

Минимальные сроки поставки, гибкие цены, неограниченный ассортимент и индивидуальный подход к клиентам являются основой для выстраивания долгосрочного и эффективного сотрудничества с предприятиями радиоэлектронной промышленности, предприятиями ВПК и научно-исследовательскими институтами России.

С нами вы становитесь еще успешнее!

Наши контакты:

Телефон: +7 812 627 14 35

Электронная почта: sales@st-electron.ru

Адрес: 198099, Санкт-Петербург,
Промышленная ул, дом № 19, литера Н,
помещение 100-Н Офис 331