

Header Board Specification

WHY DO I NEED A HEADER TO DEBUG?

Some PIC[®] microcontrollers, particularly low pin count devices (with 20 pins or less), generally must use a header for debugging. This is done to free up I/O lines for your application and to make production parts more affordable. Optional headers are also available for high pin count devices (with 64 pins or higher).

Debugging requires a two-line connection (plus VDD, VSS and VPP) to communicate with the device. In a high pin count device, losing a few I/O lines is generally not a problem for most designs. But in a low pin count device, it can be a critical problem. Imagine having to do an 8-pin design where there are only 5 I/Os, having used up 2 I/Os just for debugging!

Headers are also used to save you money. In high pin count devices, adding debugging to the silicon can generally be done at little or no cost since the silicon is already fairly large. However, low pin count devices are low cost specifically because they use very little silicon. So, adding debugging circuitry on-board these parts would add significant cost since it would raise the amount of silicon used by a considerable percentage. The header places the cost for debugging up front and frees your production parts from the extra cost of an unused debug module.

Microchip also makes optional debug modules, usually for high pin count devices. The module is optional because you can still do basic debugging without a header, but if you use one, you get back I/O lines, and may also gain additional debugging features. Only certain devices can use an optional header, see the device page on our website for details.

Microchip lists what header must be ordered to work with your device, if one is required. Simply consult the device page on our website, or our other ordering guides.

Note that in all cases, devices can be programmed “in circuit” (called ICSP™) with very few exceptions. Even devices without an internal debug feature can still be programmed by connecting the programming/debugging tool to the in-circuit programming lines. These devices simply cannot perform debugging without a header.

FIGURE 1: PRODUCTION DEVICE VS. HEADER DEVICE (-ICE/-ICD)

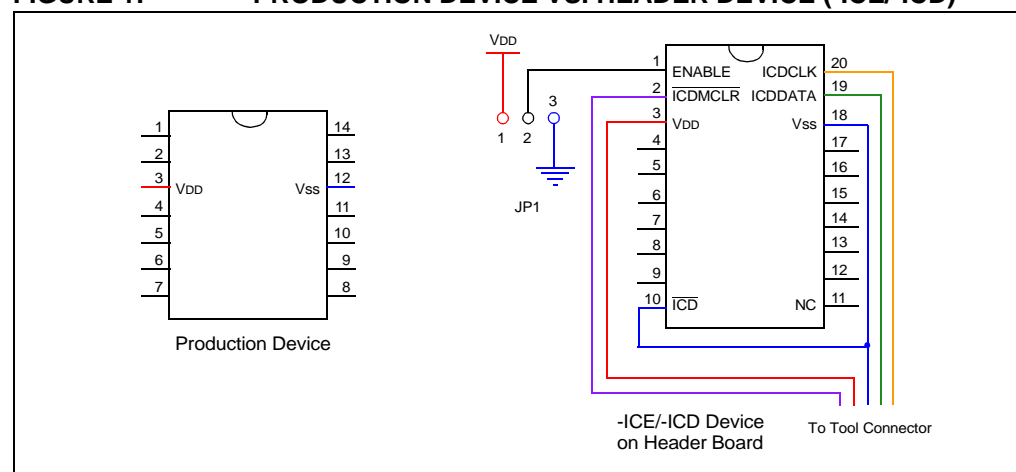

Header Board Specification

DEBUG DETAILS

Next generation in-circuit emulators (such as the MPLAB® REAL ICE™ in-circuit emulator) and in-circuit debuggers work with devices that have on-chip debug circuitry. Sometimes the actual production device will have this circuitry and sometimes a special version of this device is required or available for code debugging. This special version of the chip, with the suffix -ICD or -ICE, is mounted on a header board (Figure 2).

Note: ICE/ICD devices are only used on the header; they are not sold separately.

FIGURE 2: DEBUG OPTIONS

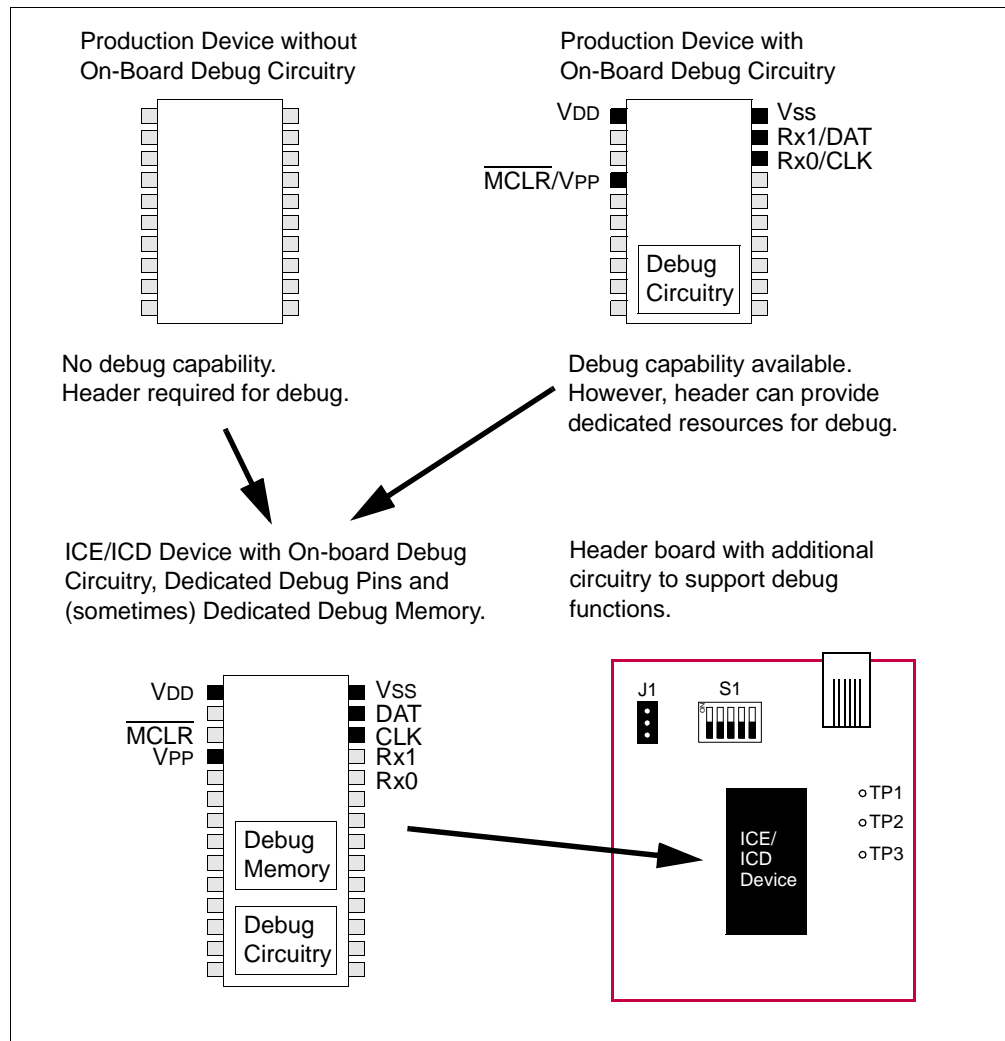

In general, ICE devices are designed for next-generation in-circuit emulator use and ICD devices are designed for in-circuit debugger use. However, ICE devices may be used with an in-circuit debugger and ICD devices may be used with a next-generation in-circuit emulator, but will provide only basic ICD functionality.

To determine what device resources must be dedicated to debugging for either a device with on-board debug capability or the special ICE/ICD device, see the “Resources used by ...” section of the in-circuit emulator or in-circuit debugger on-line help file.

Header Board Specification

PROGRAMMING DETAILS

The header board is designed to be used with the in-circuit emulator or the in-circuit debugger selected as a debugger, not a programmer, in MPLAB IDE. Any programming of the ICE/ICD device on the header is for debug purposes and includes the debug executive. See your related debug tool documentation for details on using it as a debugger.

To program production (non-ICE/ICD) devices with your debug tool, use the Universal Programming Module (AC162049) or design a modular interface connector on the target. See the appropriate specification for connections. For the most up-to-date device programming specifications, see the Microchip website (www.microchip.com).

Also, production devices may be programmed with the following tools:

- MPLAB PM3 device programmer
- PICSTART® Plus development programmer
- PICkit™ 1, 2 or 3 development programmer
- MPLAB ICD 3 in-circuit debugger (select as a programmer)
- MPLAB REAL ICE in-circuit emulator (select as a programmer)

GENERAL HEADER SETUP

To set up your header, do the following:

1. Check the header board for any stickers and the header box for any paper inserts that may specify special operating instructions (Figure 3). Follow these instructions before doing anything else.

FIGURE 3: SPECIAL HEADER INSTRUCTIONS

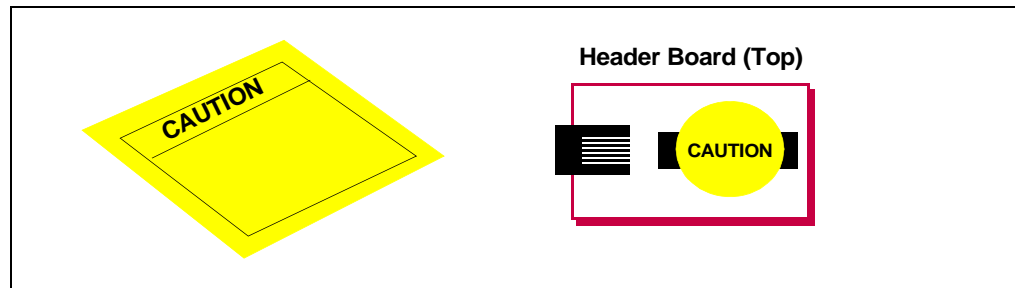

2. Set any jumpers or switches on the header to determine device functionality or selection as specified for that header. See the sections “Optional Headers” or “Required Headers” for information on how to set up individual headers.

Header Board Specification

3. Connect the header to your desired debug tool by consulting the tool documentation for connection options. An example connection is shown in Figure 4.

The special ICE/ICD device is mounted on the top of a header and its signals are routed to the emulator or debugger connector. These special device versions are labeled with the appropriate suffix (i.e., either *Device-ICE* or *Device-ICD*).

FIGURE 4: CONNECT HEADER TO DEBUG TOOL

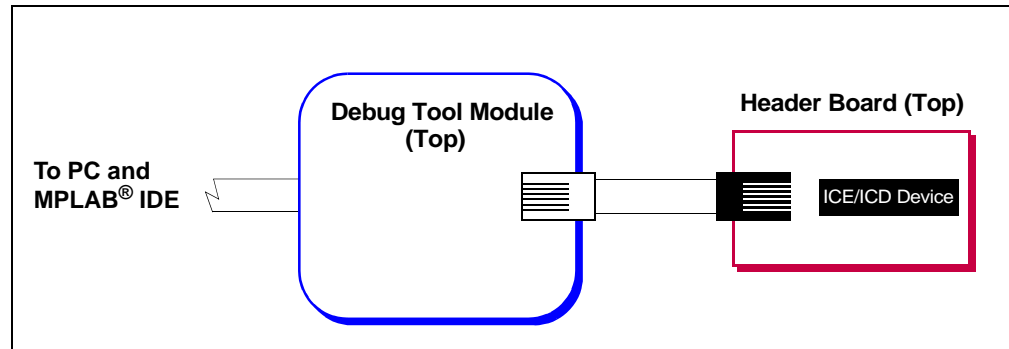

4. Connect the header to the target board. On the bottom of the header is a socket that is used to connect to the target board. The header may be connected to the target board as follows:
 - a) PDIP header socket to PDIP target socket with a stand-off (male-to-male) connector
 - b) Header socket to plug on the target board
 - c) Header socket to target socket with a transition socket (see the “*Transition Socket Specification*”, DS51194)

An example connection is shown in Figure 5.

The header socket will have the same pin count as your selected device. The ICE/ICD device on the top of the header usually has a larger pin count because it has additional pins that are dedicated to debugging.

Header Board Specification

FIGURE 5: CONNECT HEADER TO TARGET

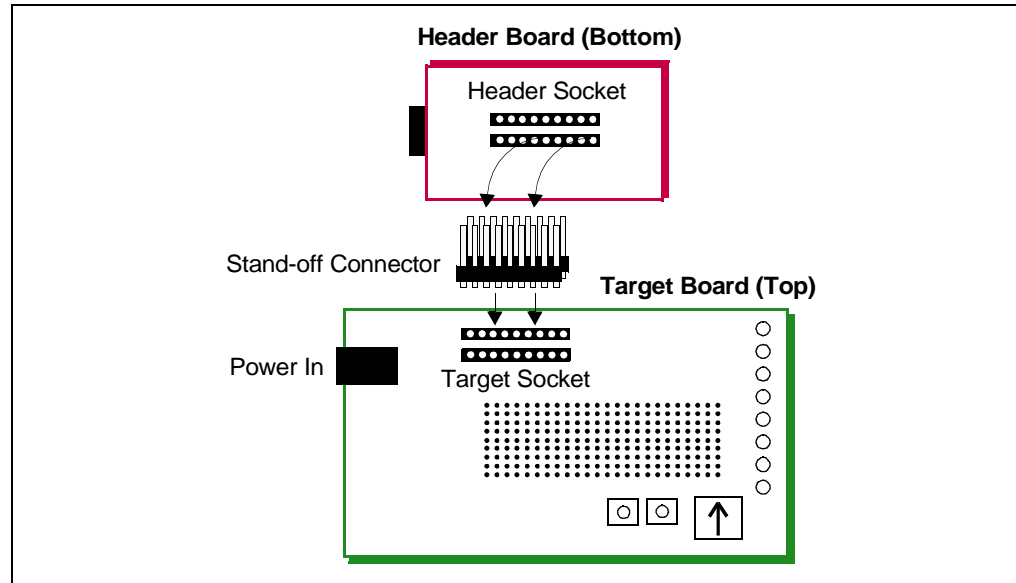

5. If using a debug tool that can power the target, power that tool now.
6. Power the target, if needed.

CALIBRATION BITS

The calibration bits for the band gap and internal oscillator are always preserved to their factory settings.

PERFORMANCE ISSUES

The PIC MCU devices do not support partial program memory erase; therefore, users may experience slower performance than with other devices.

Also, see either the in-circuit emulator or the in-circuit debugger Help file for information on specific device limitations that may affect performance.

RELATED DEBUG TOOLS

The following tools support the use of headers:

- MPLAB REAL ICE in-circuit emulator
- MPLAB ICD 2 or 3 in-circuit debugger
- PICkit 2 or 3 Debug Express

See the Microchip website (<http://www.microchip.com>) for the latest documentation.

Header Board Specification

CUSTOMER SUPPORT

Users of Microchip products can receive assistance through several channels:

- Distributor or Representative
- Local Sales Office
- Field Application Engineer (FAE)
- Technical Support

Customers should contact their distributor, representative or field application engineer (FAE) for support. Local sales offices are also available to help customers.

Technical support is available through the web site at: <http://support.microchip.com>.

Documentation errors or comments may be emailed to docerrors@microchip.com.

Required Headers

Some devices have no built-in debug circuitry. Therefore, special ICE/ICD versions of these devices are required for debug tool operation.

Currently available headers and their associated ICE/ICD devices are shown below by supported device.

TABLE 1: REQUIRED HEADERS BY DEVICE

Device	Pin Count	Header Part Number	ICE/ICD Device Used	VDD Max
PIC10F200/2/4/6	8/14	AC162059	PIC16F505-ICD	5.5V
PIC10F220/2	8/14	AC162070	PIC16F506-ICD	5.5V
PIC12F508/509	8/14	AC162059	PIC16F505-ICD	5.5V
PIC12F510	8/14	AC162070	PIC16F506-ICD	5.5V
PIC12F519	8/14	AC162096	PIC16F526-ICD	5.5V
PIC12F609/HV609	28	AC162083	PIC16F616-ICD	5.5V
PIC12F615/HV615	28	AC162083	PIC16F616-ICD	5.5V
PIC12F617	28	AC162083	PIC16F616-ICD	5.5V
PIC12F629	8	AC162050	PIC12F675-ICD	5.5V
PIC12F635	14	AC162057	PIC16F636-ICD	5.5V
PIC12F675	8	AC162050	PIC12F675-ICD	5.5V
PIC12F683	8	AC162058	PIC12F683-ICD	5.5V
PIC16F505	8/14	AC162059	PIC16F505-ICD	5.5V
PIC16F506	8/14	AC162070	PIC16F506-ICD	5.5V
PIC16F526	8/14	AC162096	PIC16F526-ICD	5.5V
PIC16F610/HV610	14/16	AC162083	PIC16F616-ICD	5.5V
PIC16F616/HV616	14/16	AC162083	PIC16F616-ICD	5.5V
PIC16F627A/628A	18	AC162053	PIC16F648A-ICD	5.5V
PIC16F630	14	AC162052	PIC16F676-ICD	5.5V
PIC16F631	20	AC162061	PIC16F690-ICD	5.5V
PIC16F636	14	AC162057	PIC16F636-ICD	5.5V
PIC16F639 ⁽¹⁾	20	AC162066	PIC16F636-ICD	5.5V
PIC16F648A	18	AC162053	PIC16F648A-ICD	5.5V
PIC16F676	14	AC162052	PIC16F676-ICD	5.5V
PIC16F677	20	AC162061	PIC16F690-ICD	5.5V
PIC16F684	14	AC162055	PIC16F684-ICD	5.5V
PIC16F685/687	20	AC162061	PIC16F690-ICD	5.5V
PIC16F688	14	AC162056	PIC16F688-ICD	5.5V
PIC16F689/690	20	AC162061	PIC16F690-ICD	5.5V

Required Headers

TABLE 1: REQUIRED HEADERS BY DEVICE (CON'T)

Device	Pin Count	Header Part Number	ICE/ICD Device Used	VDD Max
PIC16F716	18	AC162054	PIC16F716-ICD	5.5V
PIC16F785/HV785	20	AC162060	PIC16F785-ICD	5.5V
PIC18F13K50 PIC18F14K50	20	AC244023	PIC18F14K50-ICE	5.5V
PIC18LF13K50 PIC18LF14K50	20	AC244024	PIC18LF14K50-ICE	3.6V 2.75V ⁽²⁾
PIC24F04KA200 PIC24F04KA201	14 20	AC244028	PIC24F16KA102-ICE ⁽³⁾	3.6V

- Note 1:** Dual die
2: VDDCORE Max
3: Header optional for other devices

AC162050, AC162058

Header Identification

The header AC number is used for ordering the header. However, this number is not on the header board, as the board is often used for multiple headers by inserting different ICE/ICD devices. To identify these header boards, use the following information.

Header	ICE/ICD Device	Board Assembly Number
AC162050	PIC12F675-ICD	02-01662
AC162058	PIC12F683-ICD	

Header Setup and Operation

For these headers, device peripherals need to be selected by setting jumper J1 to the appropriate position. For AC162050, this will have the effect of selecting the device.

Header	Jumper J1	Function	Device Selected
AC162050	2-3	A/D Disabled	PIC12F629
	1-2	A/D Enabled	PIC12F675
AC162058	1-2	A/D Enabled	PIC12F683

Header Limitations

See the "Limitations" section in your debug tool on-line Help file for details.

Header Dimensions

The figure below lists the dimensions for the header board. Dimensions are design values in inches.

If the length and/or width of the header board is too large a footprint for the target board, consider using stand-offs, transition sockets or other extenders in the header connection socket to raise the header above the target.

FIGURE 1: DIMENSIONS – AC162050, AC162058

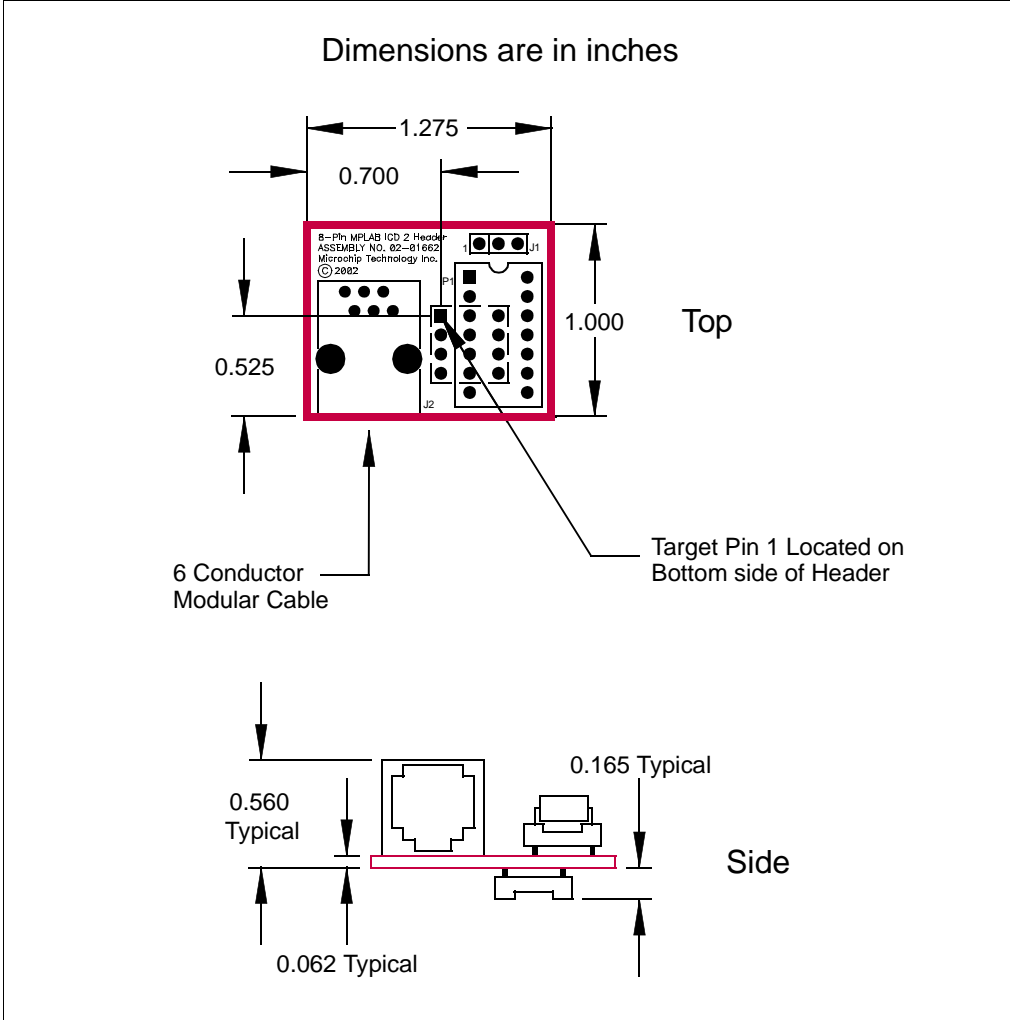

Required Headers

AC162052, AC162055, AC162056, AC162057

Header Identification

The header AC number is used for ordering the header. However, this number is not on the header board, as the board is often used for multiple headers by inserting different ICE/ICD devices. To identify these header boards, use the following information.

Header	ICE/ICD Device	Board Assembly Number
AC162052	PIC16F676-ICD	02-01686
AC162055	PIC16F684-ICD	
AC162056	PIC16F688-ICD	
AC162057	PIC16F636-ICD	

Header Setup and Operation

For these headers, device peripherals need to be selected by setting jumper J1 to the appropriate position. For AC162052 and AC162057, this will have the effect of selecting the device.

Header	Jumper J1	Function	Device Selected
AC162052	2-3	A/D Disabled	PIC16F630
	1-2	A/D Enabled	PIC16F676
AC162055	Don't care	N/A	PIC16F684
AC162056	Don't care	N/A	PIC16F688
AC162057	2-3	PORTC, Comparator 2 Disabled	PIC12F635
	1-2	PORTC, Comparator 2 Enabled	PIC16F636

Header Limitations

See the "Limitations" section in your debug tool on-line Help file for details.

Header Dimensions

The figure below lists the dimensions for the header board. Dimensions are design values in inches.

If the length and/or width of the header board is too large a footprint for the target board, consider using stand-offs, transition sockets or other extenders in the header connection socket to raise the header above the target.

FIGURE 2: DIMENSIONS – AC162052, AC162055, AC162056, AC162057

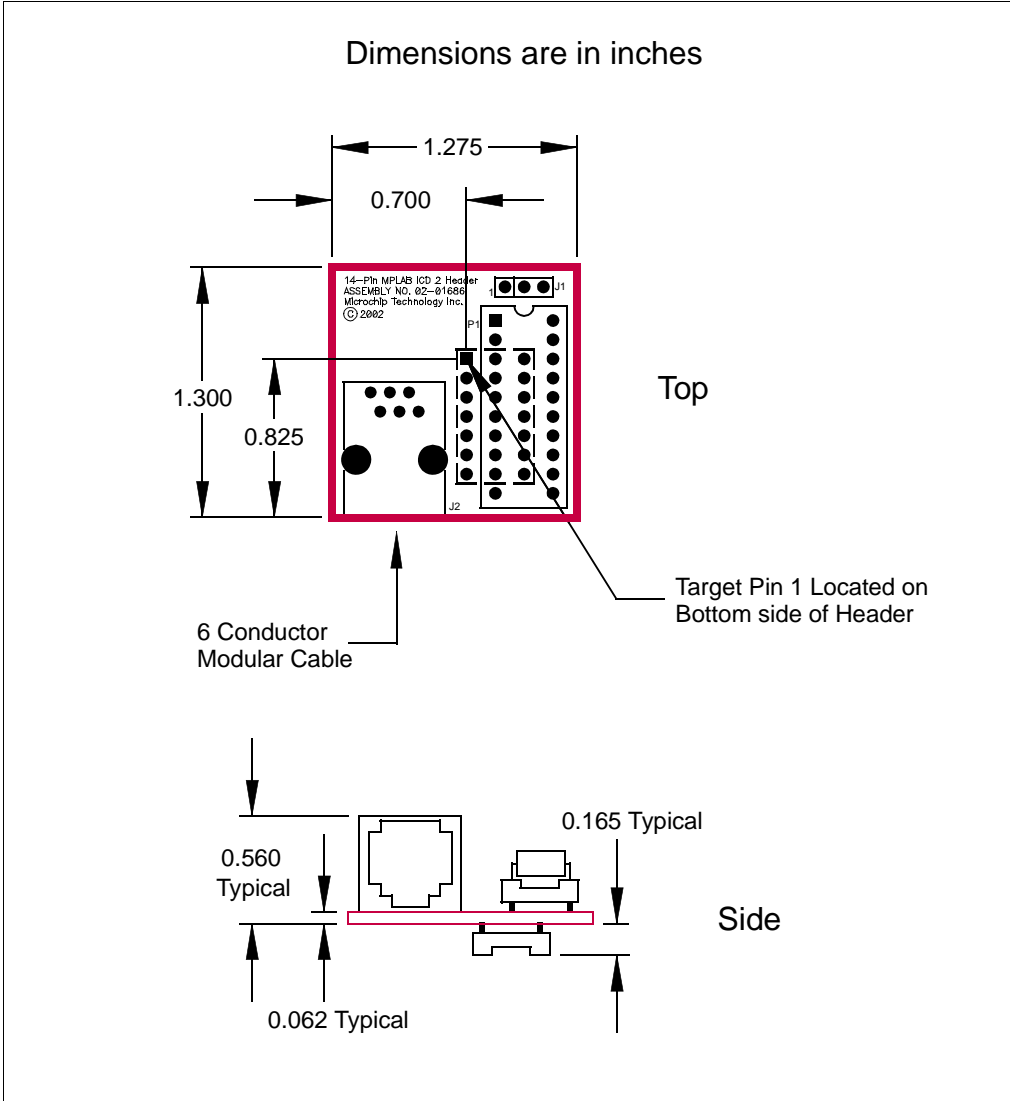

Required Headers

AC162053, AC162054

Header Identification

The header AC number is used for ordering the header. However, this number is not on the header board, as the board is often used for multiple headers by inserting different ICE/ICD devices. To identify these header boards, use the following information.

Header	ICE/ICD Device	Board Assembly Number
AC162053	PIC16F648A-ICD	02-01695
AC162054	PIC16F716-ICD	

Header Setup and Operation – AC162053

For this headers, there are no jumpers/switches. The device with the most program memory is always selected.

If PIC16F627A or PIC16F628A devices are selected for development in MPLAB IDE, the warning “Invalid target device ID” may be received in the build window and as a dialog. The reason is the PIC16F648A-ICD device supports PIC16F648A, PIC16F627A and PIC16F628A, but only reports the device ID for the PIC16F648A.

Ignore this warning or disable it under the **Warnings** tab on the ICD Programming dialog.

Header Setup and Operation – AC162054

This header supports one device (PIC16F716) so there are no jumpers or switches.

Header Limitations

See the “Limitations” section in your debug tool on-line Help file for details.

Header Dimensions

The figure below lists the dimensions for the header board. Dimensions are design values in inches.

If the length and/or width of the header board is too large a footprint for the target board, consider using stand-offs, transition sockets or other extenders in the header connection socket to raise the header above the target.

FIGURE 3: DIMENSIONS – AC162053, AC162054

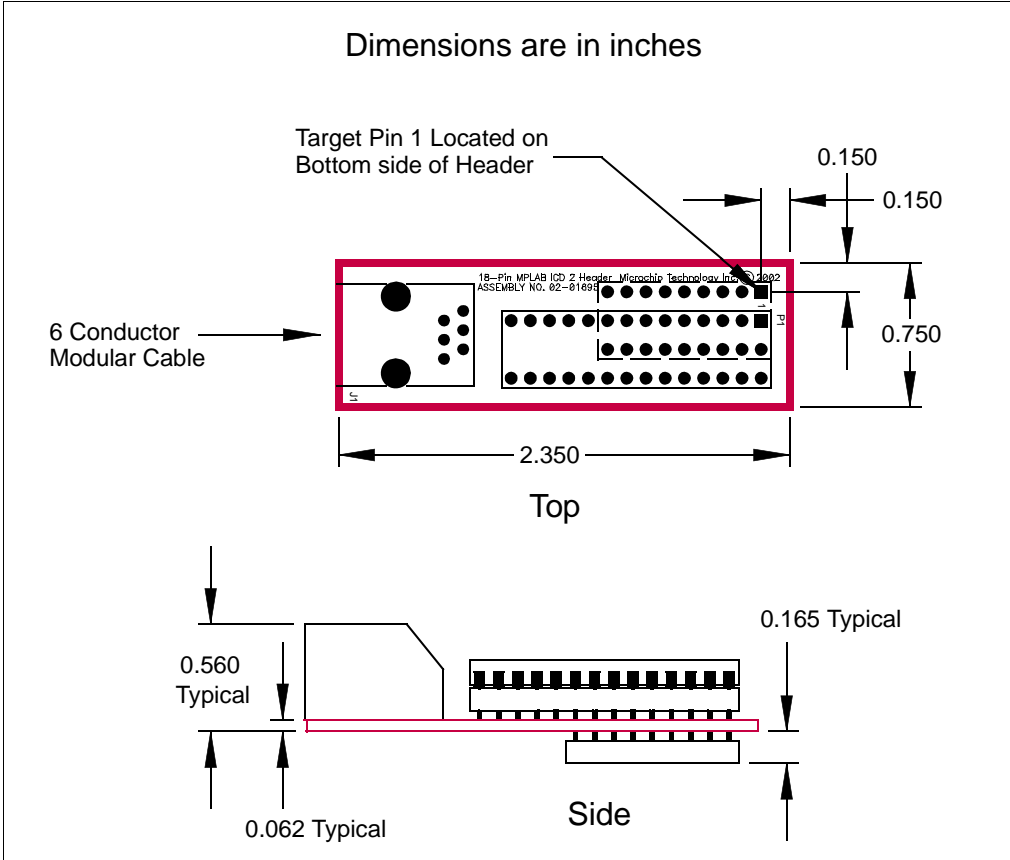

Required Headers

AC162059, AC162070, AC162096

Header Identification

The header AC number is used for ordering the header. However, this number is not on the header board, as the board is often used for multiple headers by inserting different ICE/ICD devices. To identify these header boards, use the following information.

Header	ICE/ICD Device	Board Assembly Number
AC162059	PIC16F505-ICD	02-01803
AC162070	PIC16F506-ICD	
AC162096	PIC16F526-ICD	

Header Setup and Operation

The ICD devices on these headers are specifically designed to select a device without the use of additional jumpers or switches.

These headers support 8 and 14-pin devices (see Figure 4.) For the AC162059 and AC162070, there is an 8-pin and a 14-pin connector. For the AC162096, there is only a 14-pin connector. (The 8-pin connector is not populated.) Use the 14-pin connector for 8-pin devices, but make sure device pin 1 is placed at the 14-pin connector pin 1.

Header Limitations

See the "Limitations" section in your debug tool on-line Help file for details.

Header Dimensions

The figure below lists the dimensions for the header board. Dimensions are design values in inches.

If the length and/or width of the header board is too large a footprint for the target board, consider using stand-offs, transition sockets or other extenders in the header connection socket to raise the header above the target.

FIGURE 4: DIMENSIONS – AC162059, AC162070, AC162096

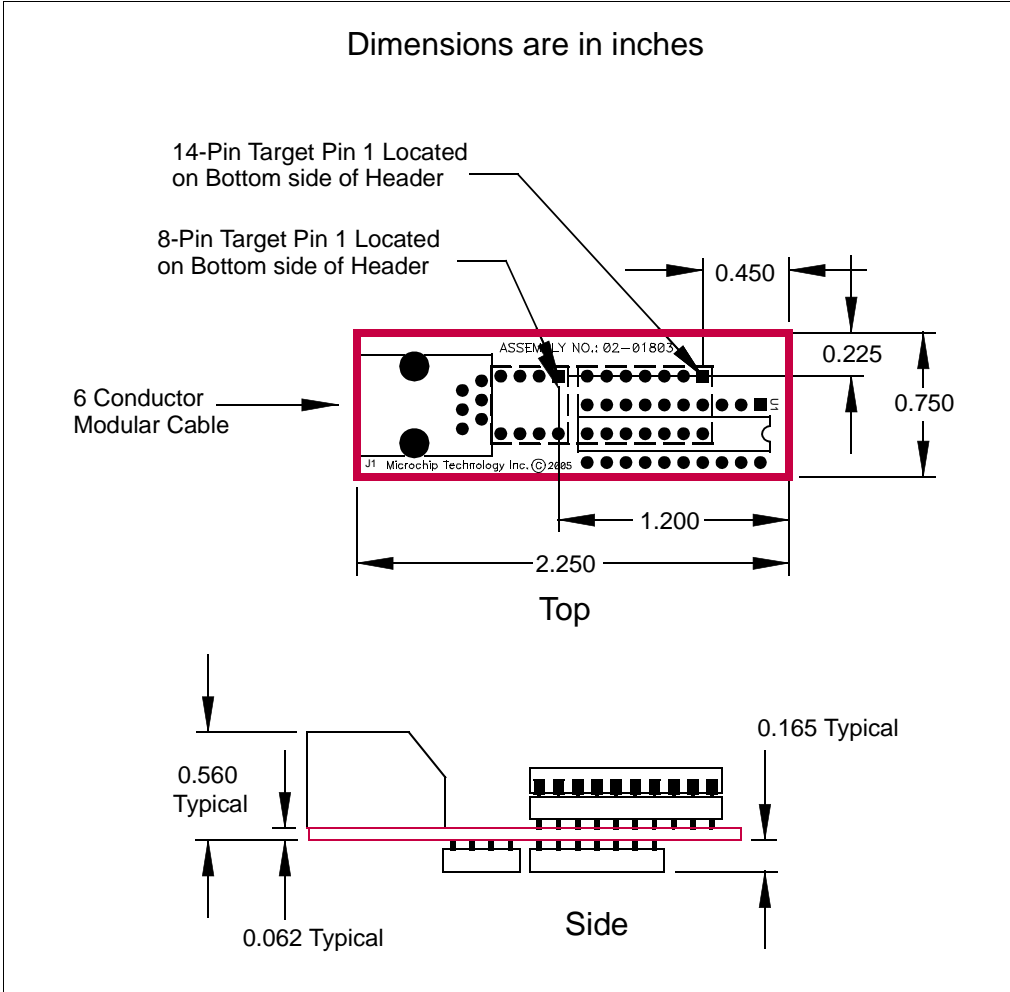

Required Headers

AC162060

Header Identification

The header AC number is used for ordering the header. However, this number is not on the header board, as the board is often used for multiple headers by inserting different ICE/ICD devices. To identify this header board, use the following information.

Header	ICE/ICD Device	Board Assembly Number
AC162060	PIC16F785-ICD	02-01820

Header Setup and Operation

For the PIC16F785 20-pin header, you will need to connect the jumper J2 to enable the shunt regulator.

Device	Device Type	Jumper J2	Function
PIC16F785	F	1-2	Disable shunt regulator
PIC16HV785	HV	2-3	Enable shunt regulator

Header Limitations

See the "Limitations" section in your debug tool on-line Help file for details.

Header Dimensions

The figure below lists the dimensions for the header board. Dimensions are design values in inches.

If the length and/or width of the header board is too large a footprint for the target board, consider using stand-offs, transition sockets or other extenders in the header connection socket to raise the header above the target.

FIGURE 5: DIMENSIONS – AC162060

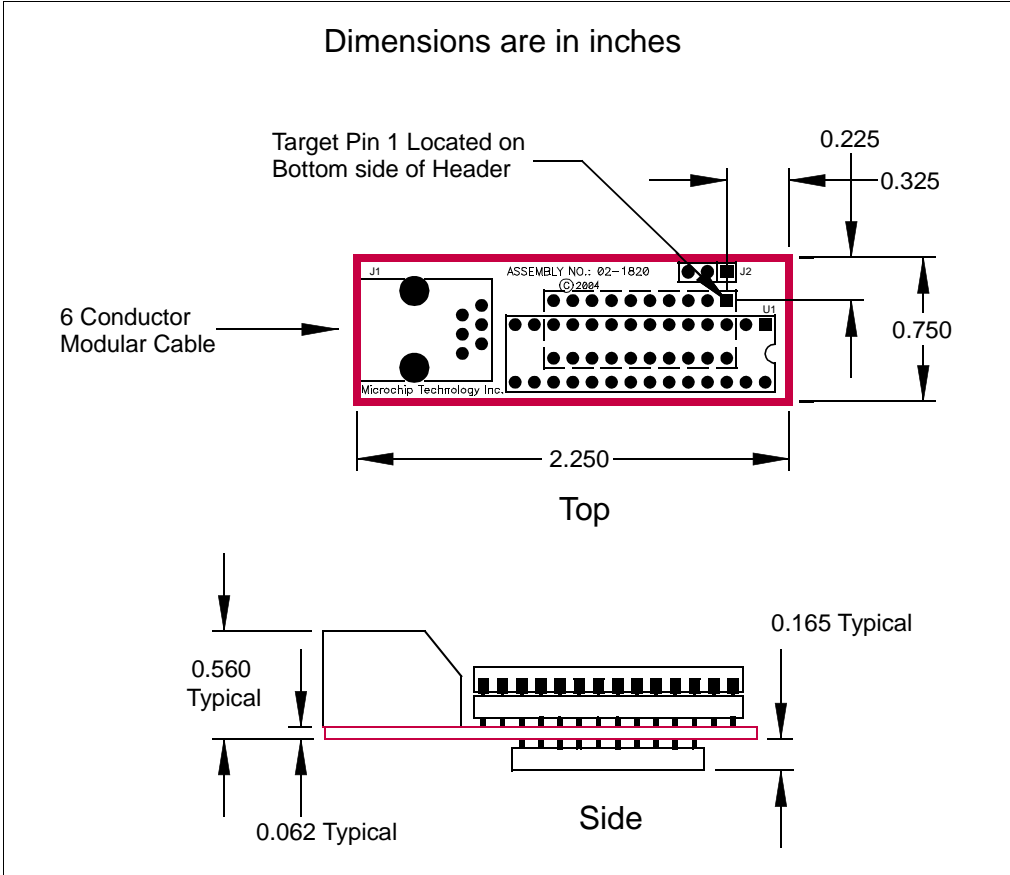

Required Headers

AC162061

Header Identification

The header AC number is used for ordering the header. However, this number is not on the header board, as the board is often used for multiple headers by inserting different ICE/ICD devices. To identify this header board, use the following information.

Header	ICE/ICD Device	Board Assembly Number
AC162061	PIC16F690-ICD	02-01835

Header Setup and Operation

For the PIC16F690 20-pin header, you will need to set the S1 switches (Figure 6) to enable peripherals and choose devices (Table).

FIGURE 6: S1 SWITCH HARDWARE

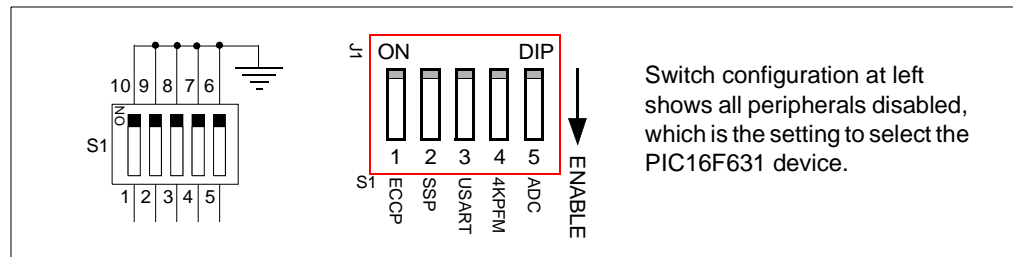

TABLE 2: S1 SWITCH DEVICE SELECTION

Device	Switches				
	1 ECCP	2 SSP	3 USART	4 4k PFM	5 ADC
PIC16F631	0	0	0	0*	0
PIC16F677	0	1	0	0**	1
PIC16F685	1	0	0	1	1
PIC16F687	0	1	1	0**	1
PIC16F689	0	1	1	1	1
PIC16F690	1	1	1	1	1

Legend: 1 = Enabled 0 = Disabled * = 1k PFM ** = 2k PFM

Header Limitations

See the "Limitations" section in your debug tool on-line Help file for details.

Header Dimensions

The figure below lists the dimensions for the header board. Dimensions are design values in inches.

If the length and/or width of the header board is too large a footprint for the target board, consider using stand-offs, transition sockets or other extenders in the header connection socket to raise the header above the target.

FIGURE 7: DIMENSIONS – AC162061

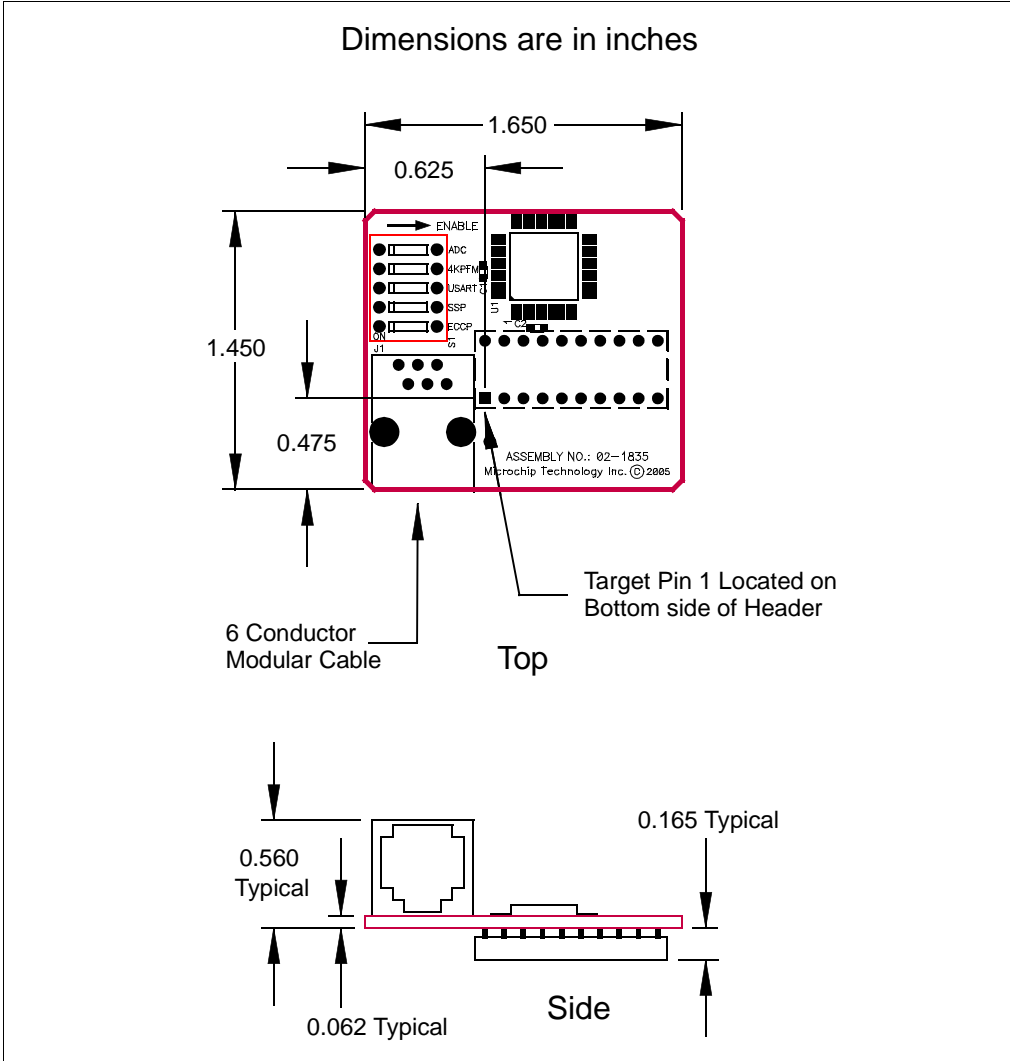

Required Headers

AC162066

Header Identification

The header AC number is used for ordering the header. However, this number is not on the header board, as the board is often used for multiple headers by inserting different ICE/ICD devices. To identify this header board, use the following information.

Header	ICE/ICD Device	Board Assembly Number
AC162066	PIC16F636-ICD	02-01832

Header Setup and Operation

For the PIC16F639 20-pin header, you will need to connect the jumper J3 as specified below.

Tool	Jumper J3	Function
MPLAB [®] ICE 2000	1-2	Run/program as production device
In-circuit debuggers, next generation in-circuit emulators	2-3	Run/program as ICD device

In addition to being used with debug tools that normally use headers, this header is used with the PCM16YM0 processor module to emulate a PIC16F639 on the MPLAB ICE 2000 in-circuit emulator. Plug the end of the processor module into the header, and then plug the header into the transition socket or directly onto the target board.

Header Limitations

See the "Limitations" section in your debug tool on-line Help file for details.

Header Dimensions

The figure below lists the dimensions for the header board. Dimensions are design values in inches.

If the length and/or width of the header board is too large a footprint for the target board, consider using stand-offs, transition sockets or other extenders in the header connection socket to raise the header above the target.

FIGURE 8: DIMENSIONS – AC162066

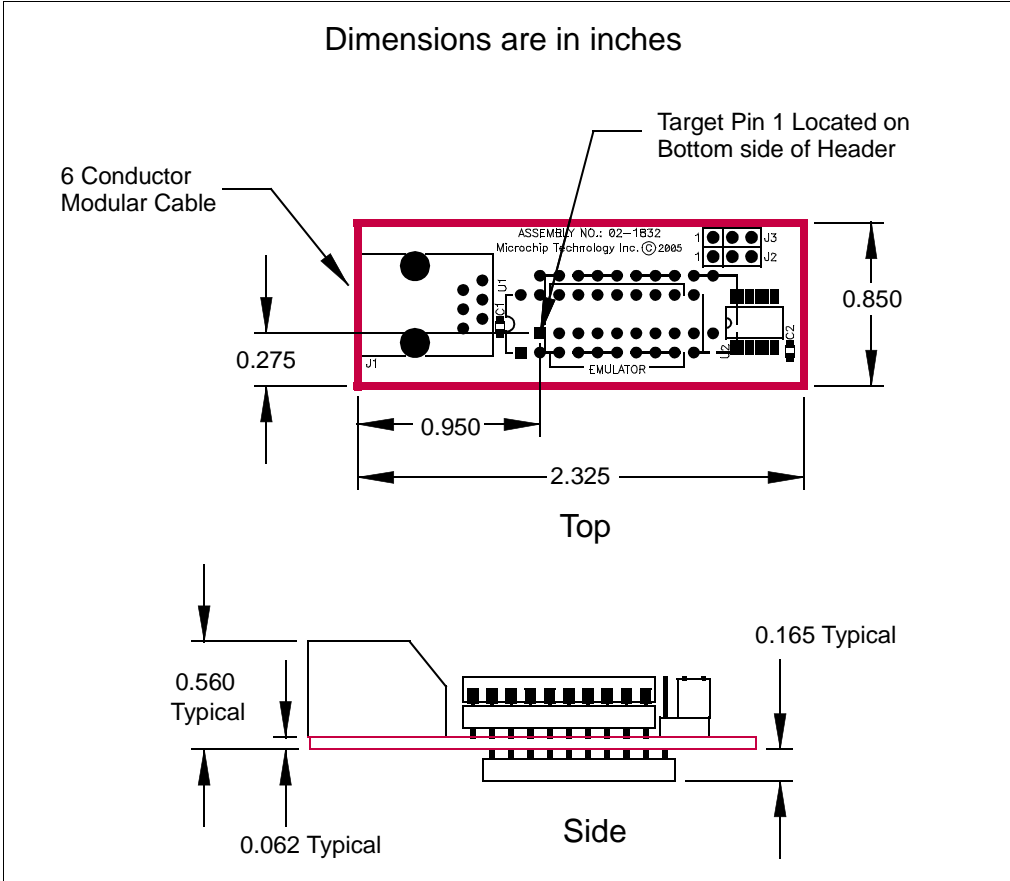

Required Headers

AC162083

Header Identification

The header AC number is used for ordering the header. However, this number is not on the header board, as the board is often used for multiple headers by inserting different ICE/ICD devices. To identify this header board, use the following information.

Header	ICE/ICD Device	Board Assembly Number
AC162083	PIC16F616-ICD	02-01976

Header Setup and Operation

CAUTION



Incorrect rotary switch (Figure 9) settings may irreparably damage the header. Ensure rotary switch settings are correct (Table 3) before powering or connecting the header. Do not change the rotary switch setting while the header is powered or connected to a debug tool. Do not power shunt regulator (HV) devices from the debug tool.

Test points are available on this header to check the following: Ground (TP1), VDD (TP2), ICD Clock (TP3), ICD Data (TP4) and ICD MCLR/VPP (TP5).

TABLE 3: ROTARY SWITCH SETTINGS

Switch Position	Device	Switch Position	Device
0	PIC12HV609	8	PIC12F609
1	PIC12HV615	9	PIC12F615
2	Reserved HV	A	PIC12F617
3	PIC16HV610	B	PIC16F610
4	PIC16HV616	C	PIC16F616
5	Reserved HV	D	Reserved F
6	Reserved HV	E	Reserved F
7	Reserved HV	F	Reserved F

POTENTIAL ISSUES

HV device selected instead of F device

If you inadvertently select a shunt regulator (HV) device and attempt to use it in a target board designed for a non-shunt regulator (F) device, the shunt may draw excessive current due to the lack of current-limiting circuitry on the target board and damage the device mounted on the header.

F device selected instead of HV device

If you inadvertently select a non-shunt regulator (F) device and attempt to use it in a target board designed for a shunt regulator (HV) device, the device may draw excessive current due to the higher voltage used on a target board designed for HV devices and damage the device mounted on the header.

HV devices cannot be powered from debug tool

Do not select in MPLAB IDE to power the target (debug header) from the debug tool (if it supports powering the target) when using shunt regulator (HV) devices since this will also cause the shunt to draw excessive current.

DETERMINING DAMAGE

A damaged header will cause MPLAB IDE to report a device ID of 0. However, there are other issues that can cause the device ID to report as 0. Please consult your debug tool documentation on troubleshooting to identify the problem. If you believe you have a damaged header, please contact Microchip technical support at <http://support.microchip.com>.

Header Limitations

See the "Limitations" section in your debug tool on-line Help file for details.

Header Dimensions

The figure below lists the dimensions for the header board. Dimensions are design values in inches.

If the length and/or width of the header board is too large a footprint for the target board, consider using stand-offs, transition sockets or other extenders in the header connection socket to raise the header above the target.

FIGURE 9: DIMENSIONS – AC162083

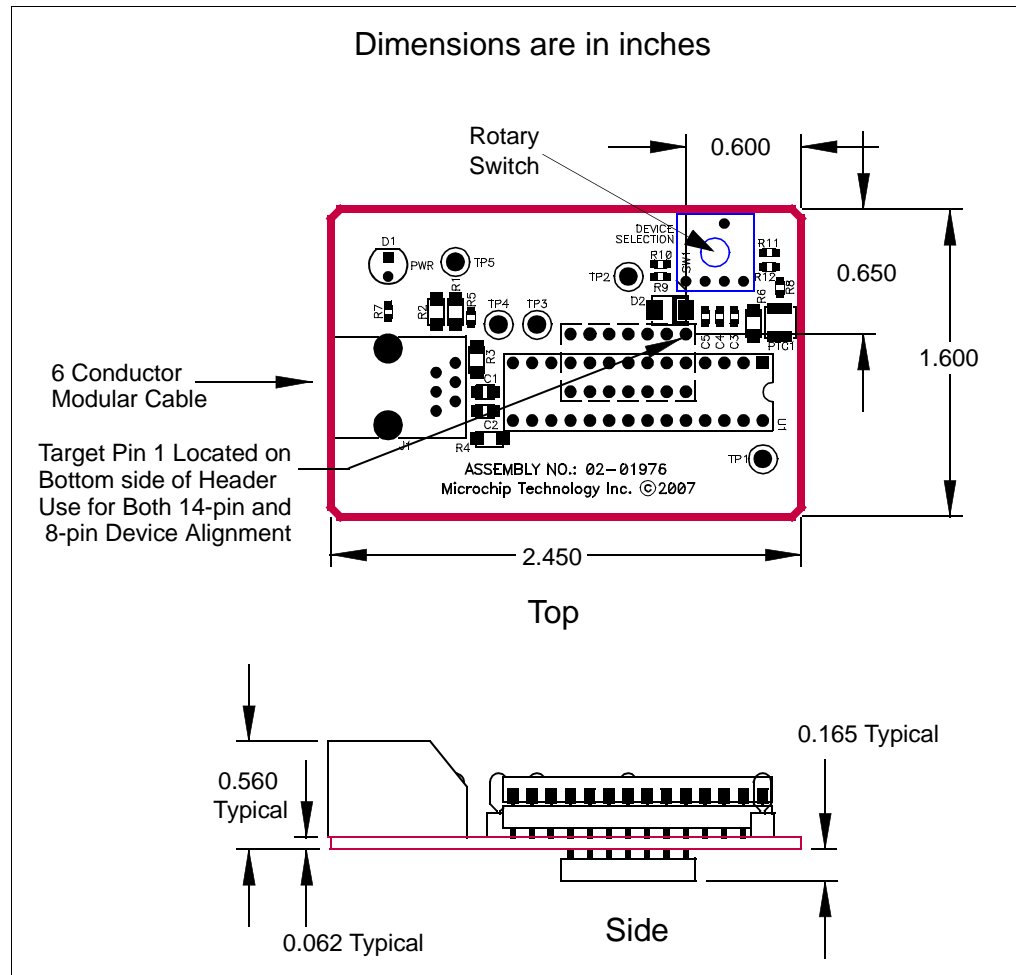

Required Headers

AC244023, AC244024

Header Identification

The header AC number is used for ordering the header. However, this number is not on the header board, as the board is often used for multiple headers by inserting different ICE/ICD devices. To identify these header boards, use the following information.

Header	ICE/ICD Device	Board Assembly Number
AC244023	PIC18F14K50-ICE	02-02031
AC244024	PIC18LF14K50-ICE	

Header Setup and Operation

When the MPLAB ICD 2 is used with this header, you must use the Vpp Limiter (AC164112).

FIGURE 10: VPP LIMITER SCHEMATIC

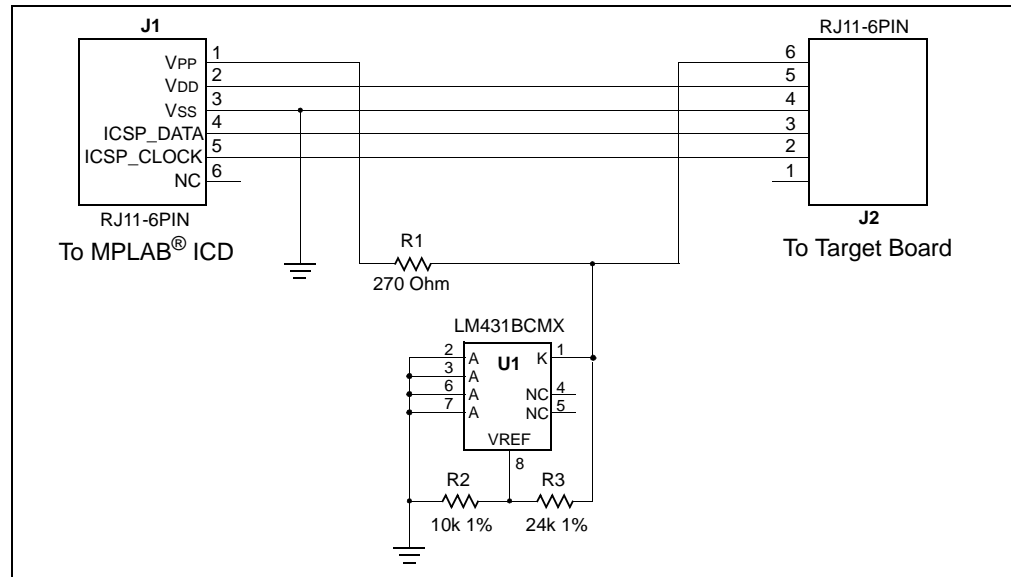

Header Limitations

See the "Limitations" section in your debug tool on-line Help file for details.

Header Dimensions

The figure below lists the dimensions for the header board. Dimensions are design values in inches.

If the length and/or width of the header board is too large a footprint for the target board, consider using stand-offs, transition sockets or other extenders in the header connection socket to raise the header above the target.

FIGURE 11: DIMENSIONS – AC244023, AC224024

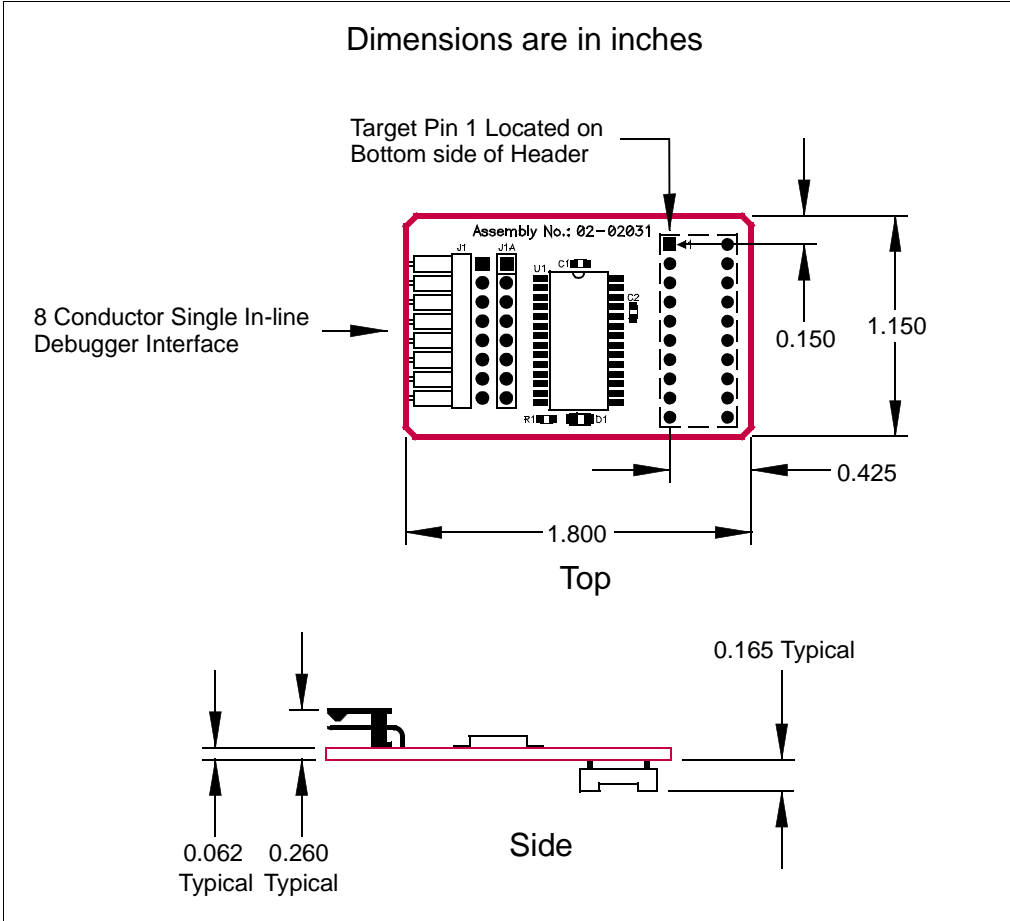

Required Headers

AC244028

Header Identification

The header AC number is used for ordering the header. However, this number is not on the header board, as the board is often used for multiple headers by inserting different ICE/ICD devices. To identify this header board, use the following information.

Header	ICE/ICD Device	Board Assembly Number
AC244028	PIC24F16KA102-ICE	02-02107

Header Setup and Operation

For this header, you will need to set up jumper J2 and J3.

Jumper	Setting	Function
J2	Open	Disable weak ICE/MCLR pull-up resistor
	Short	Enable weak ICE/MCLR pull-up resistor
J3	Open	Disable power LED indicator
	Short	Enable power LED indicator

Header Limitations

See the "Limitations" section in your debug tool on-line Help file for details.

Header Dimensions

The figure below lists the dimensions for the header board. Dimensions are design values in inches.

If the length and/or width of the header board is too large a footprint for the target board, consider using stand-offs, transition sockets or other extenders in the header connection socket to raise the header above the target.

FIGURE 12: DIMENSIONS – AC244028

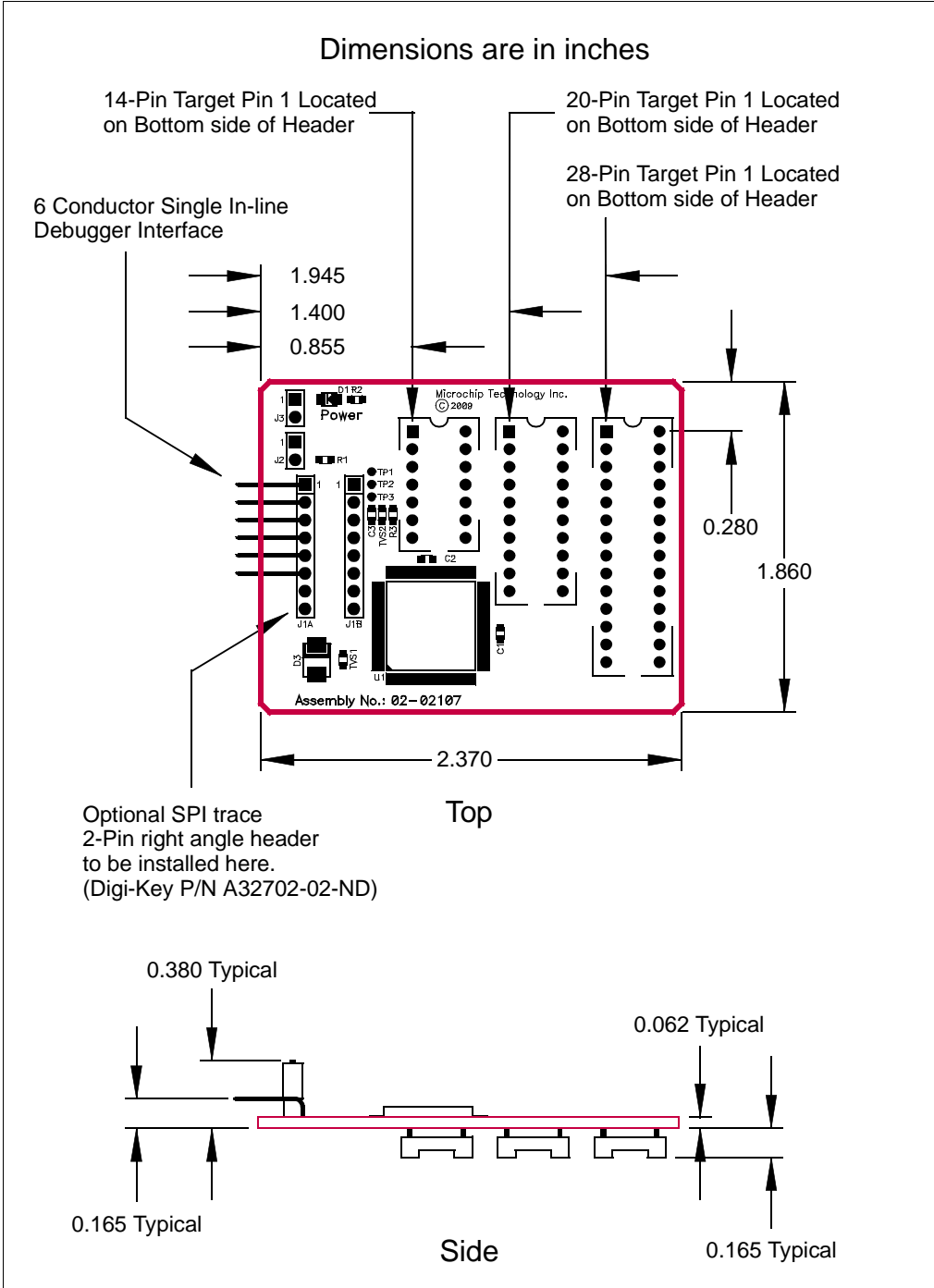

Required Headers

NOTES:

Optional Headers

Devices that have built-in debug circuitry do not require a header to use debug tools. However, some pins and memory must be used to support the debug function. Special ICE/ICD versions offering additional pins, memory and emulator functions can be used to provide superior emulating/debugging capabilities.

Currently available headers and their associated ICE/ICD devices are shown below by supported device.

TABLE 1: OPTIONAL HEADERS BY DEVICE

Device	Pin Count	Header Part Number	ICE/ICD Device Used	VDD Max
PIC16F722 PIC16F723 PIC16F724 PIC16F726 PIC16F727	28 28 40/44 28 40/44	AC244026	PIC16F727-ICE	5.5V
PIC16LF722 PIC16LF723 PIC16LF724 PIC16LF726 PIC16LF727	28 28 40/44 28 40/44	AC244027	PIC16LF727-ICE	3.6V
PIC18F1230/1330	28	AC162078	PIC18F1330-ICD	5.5V
PIC18F13K22 PIC18F14K22	20	AC244033	PIC18F14K22-ICE	5.5V
PIC18LF13K22 PIC18LF14K22	20	AC244034	PIC18LF14K22-ICE	3.6V 2.75V ⁽¹⁾
PIC18F24J10 PIC18F25J10	28/40	AC162067	PIC18F45J10-ICE	3.6V
PIC18LF24J10 PIC18LF25J10				3.6V 2.75V ⁽¹⁾
PIC18F44J10 PIC18F45J10				3.6V
PIC18LF44J10 PIC18LF45J10				3.6V 2.75V ⁽¹⁾
PIC18F44J10 PIC18F45J10	44	AC162074	PIC18F45J10-ICE	3.6V
PIC18LF44J10 PIC18LF45J10				3.6V 2.75V ⁽¹⁾

Note 1: VDDCORE Max

2: Header required for other devices.

Optional Headers

TABLE 1: OPTIONAL HEADERS BY DEVICE (CON'T)

Device	Pin Count	Header Part Number	ICE/ICD Device Used	Vdd Max
PIC18F63J11 PIC18F63J90 PIC18F64J11 PIC18F64J16 PIC18F64J90 PIC18F64J95 PIC18F65J11 PIC18F65J90	64/80	AC162079	PIC18F85J90-ICE	3.6V
PIC18F83J11 PIC18F83J90 PIC18F84J11 PIC18F84J16 PIC18F84J90 PIC18F84J95 PIC18F85J11 PIC18F85J90				
PIC18F65J10 PIC18F65J15 PIC18F66J10 PIC18F66J15 PIC18F67J10	64/80	AC162062	PIC18F87J10-ICE	3.6V
PIC18F85J10 PIC18F85J15 PIC18F86J10 PIC18F86J15 PIC18F87J10				
PIC18F65J16 PIC18F66J11 PIC18F66J16 PIC18F67J11	64/80	AC162091	PIC18F87J11-ICE	3.6V
PIC18F85J16 PIC18F86J11 PIC18F86J16 PIC18F87J11				
PIC18F65J50 PIC18F65J55 PIC18F66J50 PIC18F66J55 PIC18F67J50	64/80	AC162087	PIC18F87J50-ICE	3.6V
PIC18F85J50 PIC18F85J55 PIC18F86J50 PIC18F86J55 PIC18F87J50				

Note 1: VDDCORE Max

2: Header required for other devices.

TABLE 1: OPTIONAL HEADERS BY DEVICE (CON'T)

Device	Pin Count	Header Part Number	ICE/ICD Device Used	Vdd Max
PIC18F66J60 PIC18F66J65 PIC18F67J60	64/80/ 100	AC162064	PIC18F97J60-ICE	3.6V
PIC18F86J60 PIC18F86J65 PIC18F87J60				
PIC18F96J60 PIC18F96J65 PIC18F97J60				
PIC24F08KA101 PIC24F08KA102 PIC24F16KA101 PIC24F16KA102	20/28	AC244028	PIC24F16KA102-ICE ⁽²⁾	3.6V
PIC24FJ16GA002 PIC24FJ32GA002 PIC24FJ48GA002 PIC24FJ64GA002	28	AC162088	PIC24FJ64GA004-ICE	3.6V
PIC24FJ16GA004 PIC24FJ32GA004 PIC24FJ48GA004 PIC24FJ64GA004	44	AC162094		
PIC24FJ64GA006 PIC24FJ64GA008 PIC24FJ64GA010	64/80/ 100	AC162065 or AC244022	PIC24FJ128GA010-ICE	3.6V
PIC24FJ96GA006 PIC24FJ96GA008 PIC24FJ96GA010				
PIC24FJ128GA006 PIC24FJ128GA008 PIC24FJ128GA010				

Note 1: VDDCORE Max

2: Header required for other devices.

Optional Headers

AC162062, AC162079, AC162087, AC162091

Header Identification

The header AC number is used for ordering the header. However, this number is not on the header board, as the board is often used for multiple headers by inserting different ICE/ICD devices. To identify these header boards, use the following information.

Header	ICE/ICD Device	Board Assembly Number
AC162062	PIC18F87J10-ICE	02-01830
AC162079	PIC18F85J90-ICE	
AC162087	PIC18F87J50-ICE	
AC162091	PIC18F87J11-ICE	

Header Setup and Operation – AC162062

For this header, there are no jumpers/switches. MPLAB IDE will use its selected device to choose the correct device to emulate.

Test points are available on this header to check the following: VDD, VDDCORE and ground.

CAUTION

This header cannot be plugged directly into the PICDEM™ HPC Explorer Board or device damage will result.

The PICDEM HPC Explorer Board is 5V, whereas the ICD device on the header is 3.6V max. Therefore, modification to the demo board is necessary before the header can be used.

1. Switch S3 should be set to ICE.
2. Jumper J2 must be connected as shown in Figure 1 to modify the operating voltage. See demo board documentation for more information.

FIGURE 1: DEMO BOARD J2 CONNECTIONS

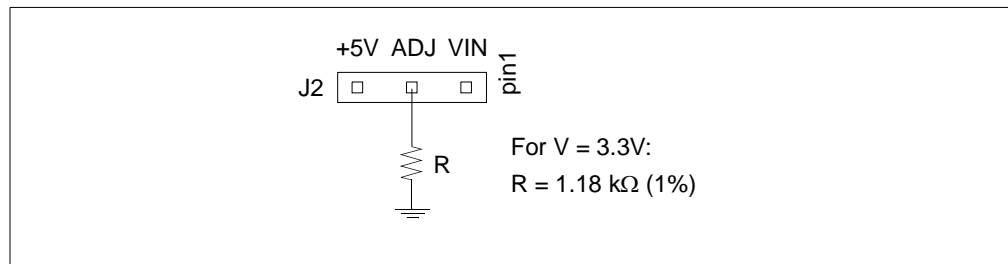

Header Setup and Operation – AC162079, AC162087, AC162091

For these headers, there are no jumpers/switches. MPLAB IDE will use its selected device to choose the correct device to emulate.

Test points are available on this header to check the following: VDD, VDDCORE and ground.

Header Limitations

See the “Limitations” section in your debug tool on-line Help file for details.

Header Dimensions

The figure below lists the dimensions for the header board. Dimensions are design values in inches.

If the length and/or width of the header board is too large a footprint for the target board, consider using stand-offs, transition sockets or other extenders in the header connection socket to raise the header above the target.

FIGURE 2: DIMENSIONS – AC162062, AC162079, AC162087, AC162091

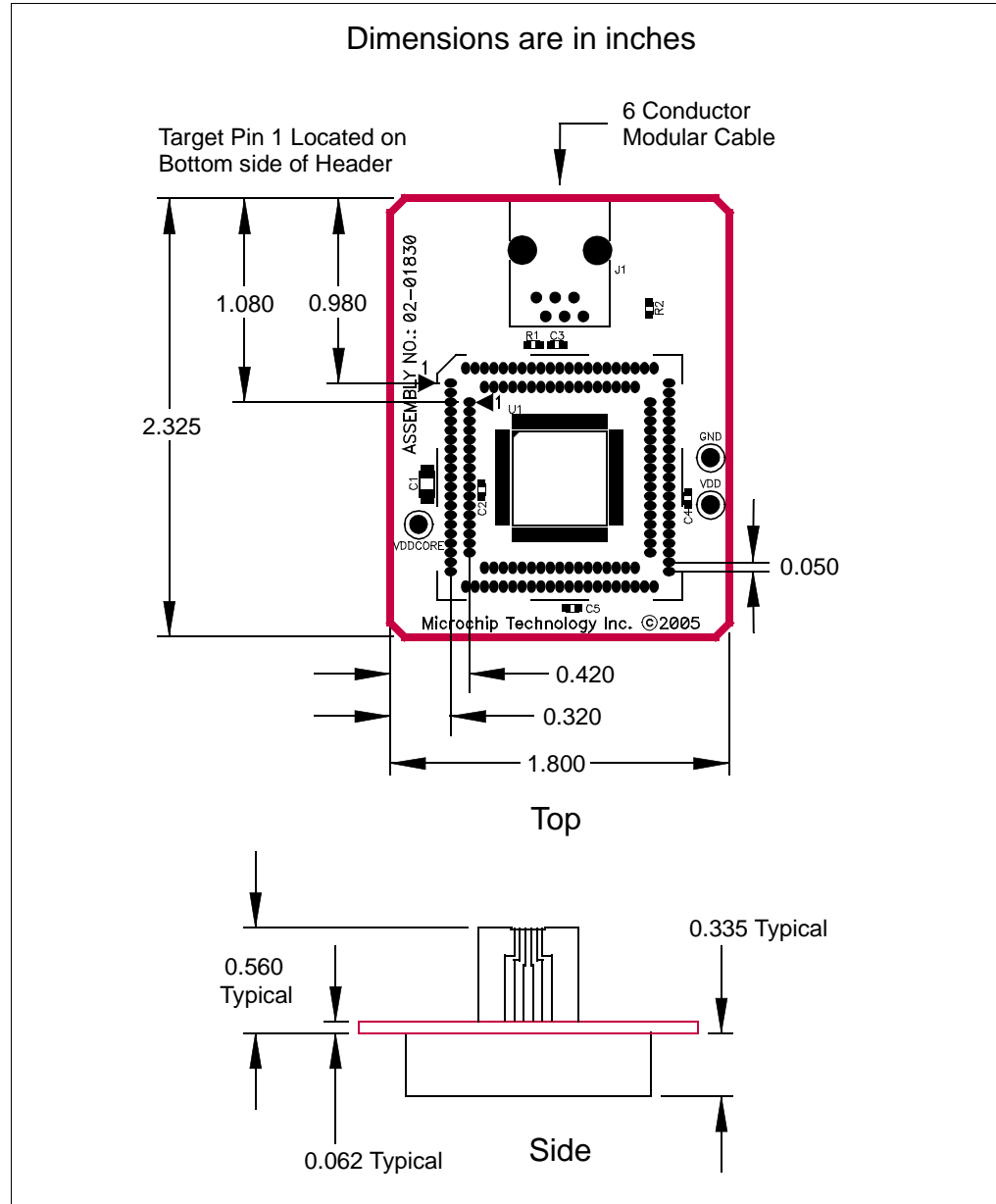

Optional Headers

AC162064

Header Identification

The header AC number is used for ordering the header. However, this number is not on the header board, as the board is often used for multiple headers by inserting different ICE/ICD devices. To identify this header board, use the following information.

Header	ICE/ICD Device	Board Assembly Number
AC162064	PIC18F97J60-ICE	02-01853

Header Setup and Operation

For this header, there are no jumpers/switches. MPLAB IDE will use its selected device to choose the correct device to emulate.

Test points are available on this header to check the following: VDD, VDDCORE and ground.

Header Limitations

See the "Limitations" section in your debug tool on-line Help file for details.

Header Dimensions

The figure below lists the dimensions for the header board. Dimensions are design values in inches.

If the length and/or width of the header board is too large a footprint for the target board, consider using stand-offs, transition sockets or other extenders in the header connection socket to raise the header above the target.

FIGURE 3: DIMENSIONS – AC162064

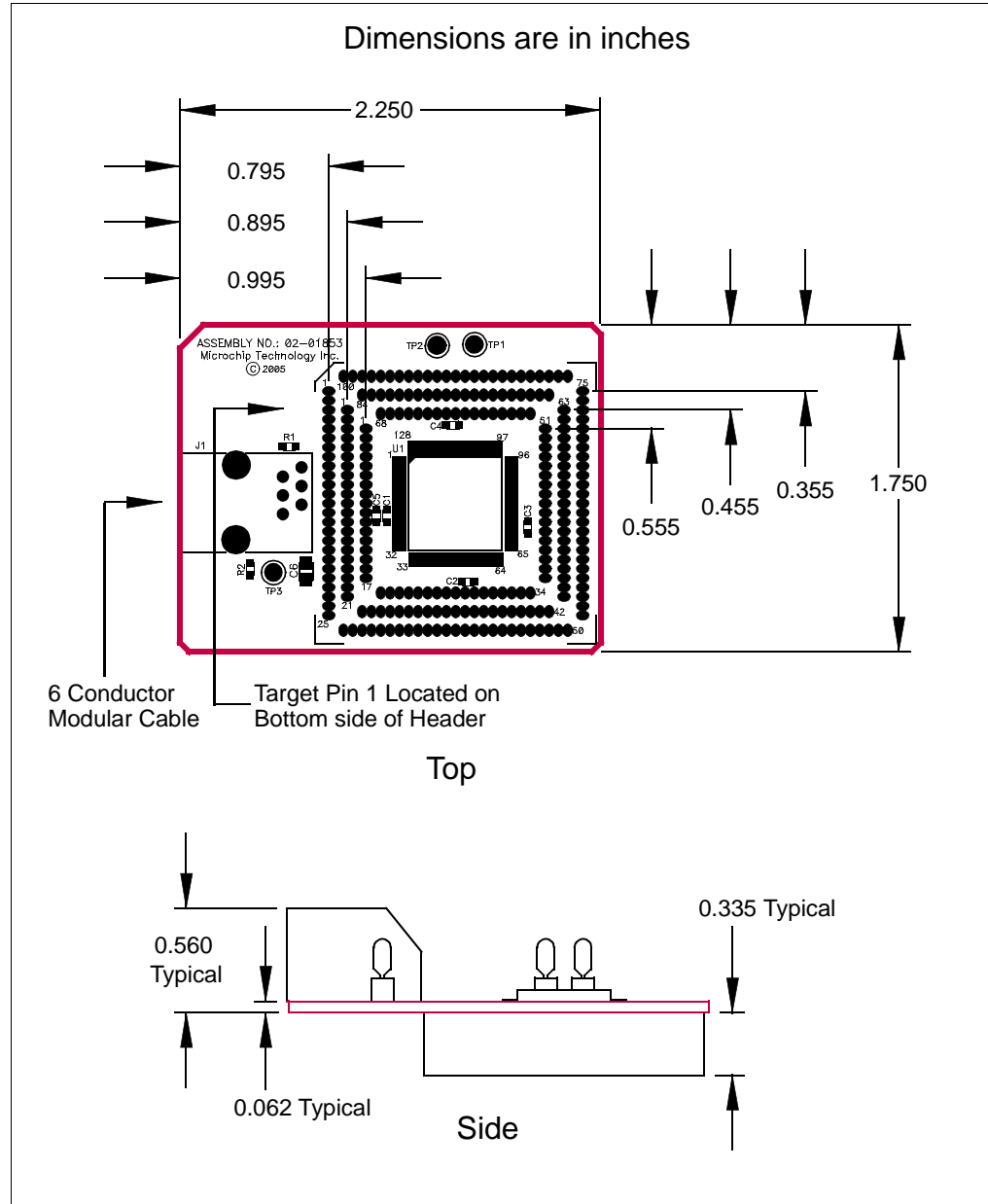

Optional Headers

AC162065, AC244022

Header Identification

The header AC number is used for ordering the header. However, this number is not on the header board, as the board is often used for multiple headers by inserting different ICE/ICD devices. To identify these header boards, use the following information.

Header	ICE/ICD Device	Board Assembly Number
AC162065	PIC24FJ128GA010-ICE	02-01856
AC244022		02-01985

Header Setup and Operation

For this header, there are no jumpers/switches. MPLAB IDE will use its selected device to choose the correct device to emulate.

Test points are available on this header to check the following: VDD, VDDCORE and ground.

Header Limitations

See the “Limitations” section in your debug tool on-line Help file for details.

Header Dimensions

The figures below lists the dimensions for the header boards. Dimensions are design values in inches.

For this device family, header AC162065 will be sold until depleted. Then only header AC244022 will remain as a Performance Pak.

If the length and/or width of the header board is too large a footprint for the target board, consider using stand-offs, transition sockets or other extenders in the header connection socket to raise the header above the target.

FIGURE 4: DIMENSIONS – AC162065

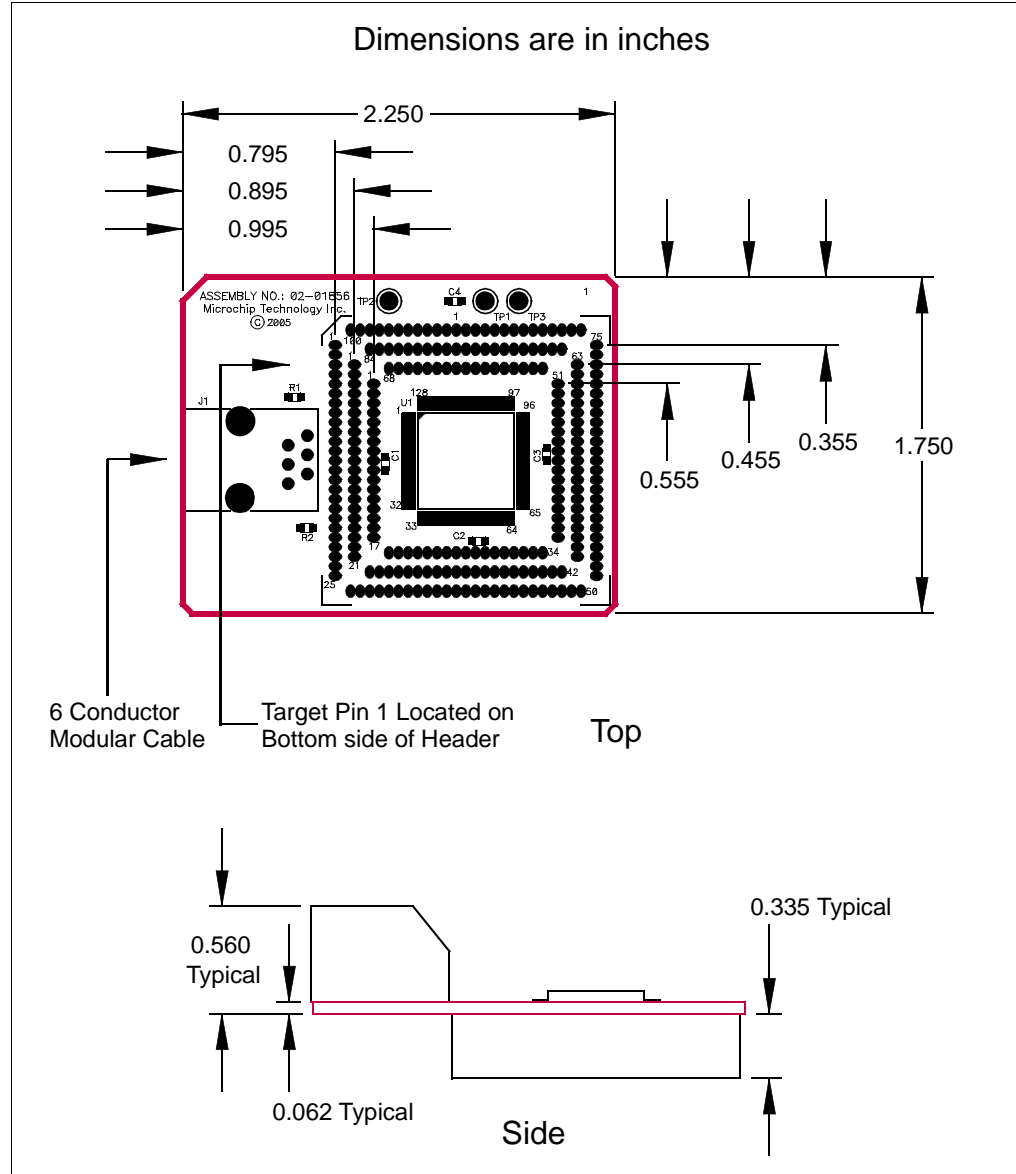

Optional Headers

FIGURE 5: DIMENSIONS – AC244022

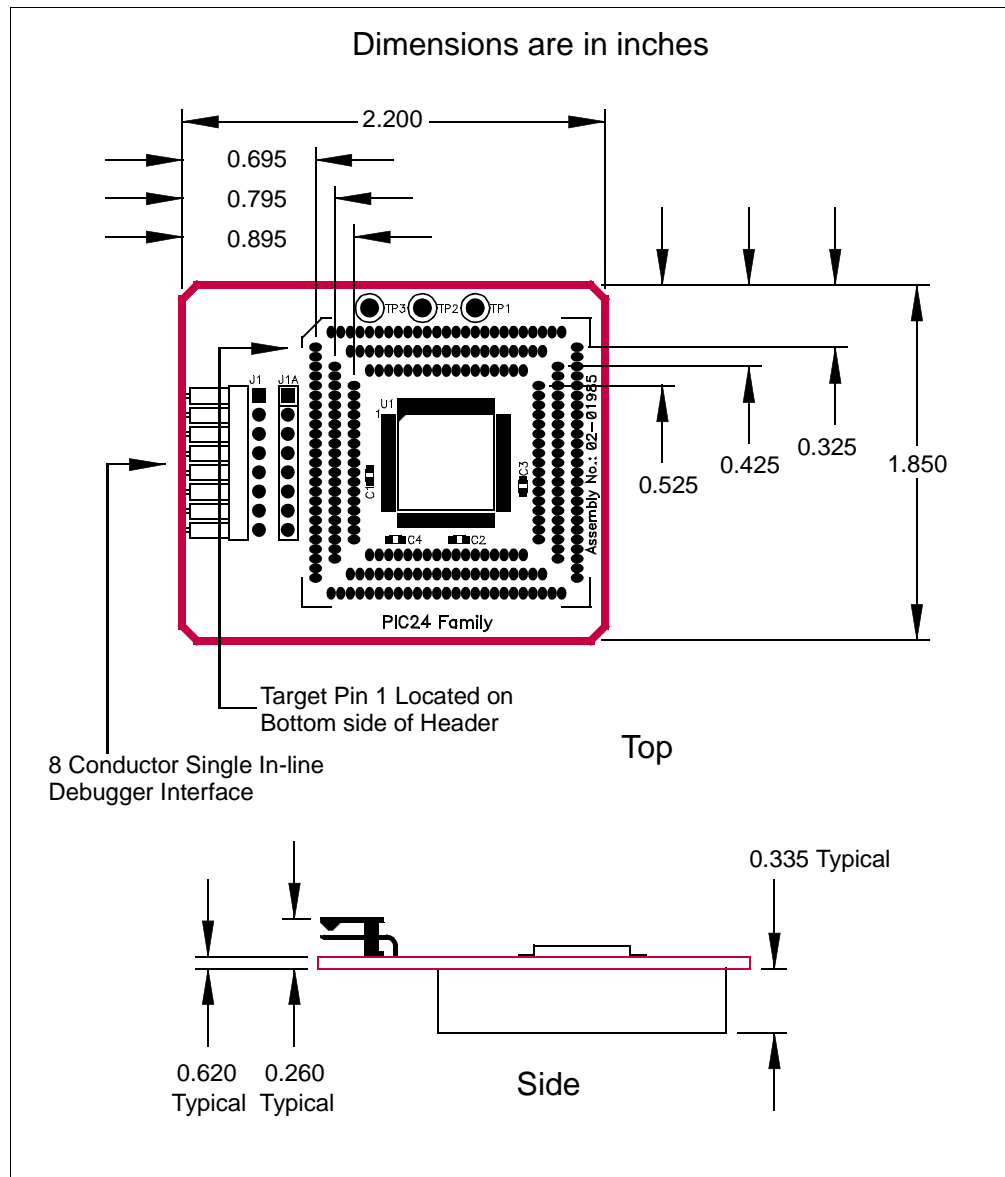

AC162067, AC162074

Header Identification

The header AC number is used for ordering the header. However, this number is not on the header board, as the board is often used for multiple headers by inserting different ICE/ICD devices. To identify these header boards, use the following information.

Header	ICE/ICD Device	Board Assembly Number
AC162067	PIC18F45J10-ICE	02-01854
AC162074		02-01929

Header Setup and Operation

For these headers, you will need to connect jumpers J2 and J3 to select between the LF and F versions of devices.

Device	Device Type	Jumper J2	Jumper J3	Function
PIC18LFXXJ10	LF	1-2	1-2	Disable voltage regulator*
PIC18FXXJ10	F	2-3	2-3	Enable voltage regulator

* VDDCORE must be supplied externally.

Header Limitations

See the “Limitations” section in your debug tool on-line Help file for details.

Header Dimensions

The figures below lists the dimensions for the header boards. Dimensions are design values in inches.

If the length and/or width of the header board is too large a footprint for the target board, consider using stand-offs, transition sockets or other extenders in the header connection socket to raise the header above the target.

Optional Headers

FIGURE 6: DIMENSIONS (28/40-PIN) – AC162067

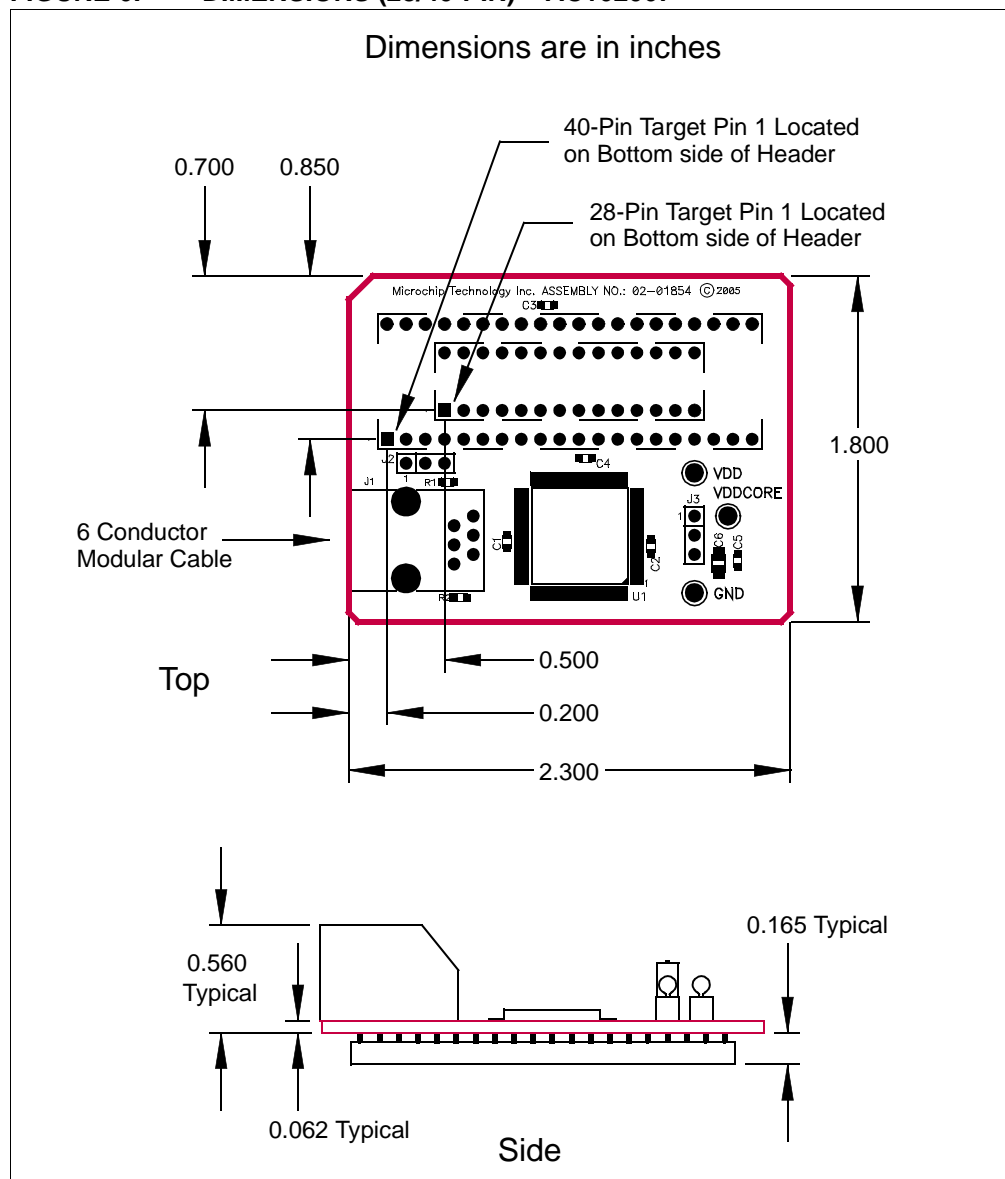
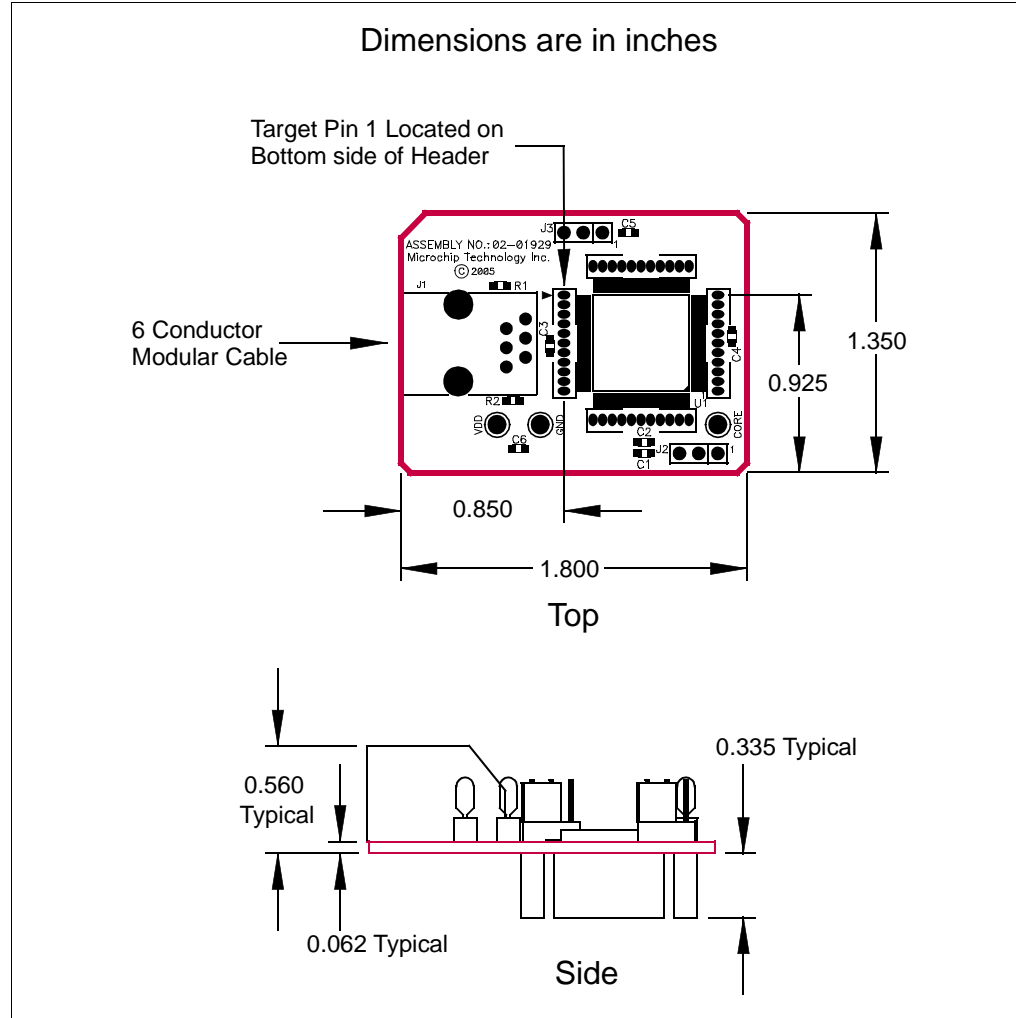

FIGURE 7: DIMENSIONS (44-PIN) – AC162074



Optional Headers

AC162078

Header Identification

The header AC number is used for ordering the header. However, this number is not on the header board, as the board is often used for multiple headers by inserting different ICE/ICD devices. To identify this header board, use the following information.

Header	ICE/ICD Device	Board Assembly Number
AC162078	PIC18F1330-ICD	02-01896

Header Setup and Operation

This header board can be used with the following targets:

1. Customer target board for PIC18F1230/1330 devices. The target board should have an 18-pin DIP socket to connect to the 18-pin DIP socket on the header board.
2. PICDEM MC motor control demo board. Use the 28-pin DIP socket on both boards to mount the header board on to the PICDEM MC board.
3. PICDEM MC LV motor control demo board. Use the 28-pin DIP socket on both boards to mount the header board on to the PICDEM MC LV board.

The following sections detail the configuration of the jumpers on the header board for use with the above mentioned boards.

CUSTOMER TARGET BOARD

The default configuration is to remove all jumpers.

S1 is not populated and should not be used.

After the header board is set up, do the following:

1. Connect the header to the target board.
2. Power the target board. You should see the red LED on the header board turn on.
3. Connect the debug tool to the header board.
4. Use MPLAB IDE and the debug tool to develop your application.

PICDEM MC/MC LV MOTOR CONTROL DEMO BOARDS

To run a BLDC motor on the PICDEM MC board or PICDEM MC LV board using the supplied firmware, use the following jumper setup:

Jumper	Jumper Setting	Jumper	Jumper Setting
J1	2-3	JP1	Open
J2	2-3		
J3	2-3	JP2	Open
J5	2-3		
J6	1-2	JP3	Open
J7	1-2		

S1 is not populated and should not be used.

After the header board is set up, do the following:

1. Connect the header to the PICDEM MC/MC LV target board.
2. Power the target board. You should see the red LED on the header board turn on.
3. Connect the debug tool to the header board.
4. Program the part with the demo code.
5. Run the program.
6. Press and release switch S2 on the target board to toggle the direction of the motor's rotation.
7. Press and release switch S1 on the target board to toggle between running and stopping the motor.
8. If the motor stops while reversing from a high speed, there could be an overcurrent condition detected by the system. Reset the system to run the program again.

Header Limitations

See the "Limitations" section in your debug tool on-line Help file for details.

Optional Headers

Header Dimensions

The figure below lists the dimensions for the header board. Dimensions are design values in inches.

If the length and/or width of the header board is too large a footprint for the target board, consider using stand-offs, transition sockets or other extenders in the header connection socket to raise the header above the target.

FIGURE 8: DIMENSIONS – AC162078

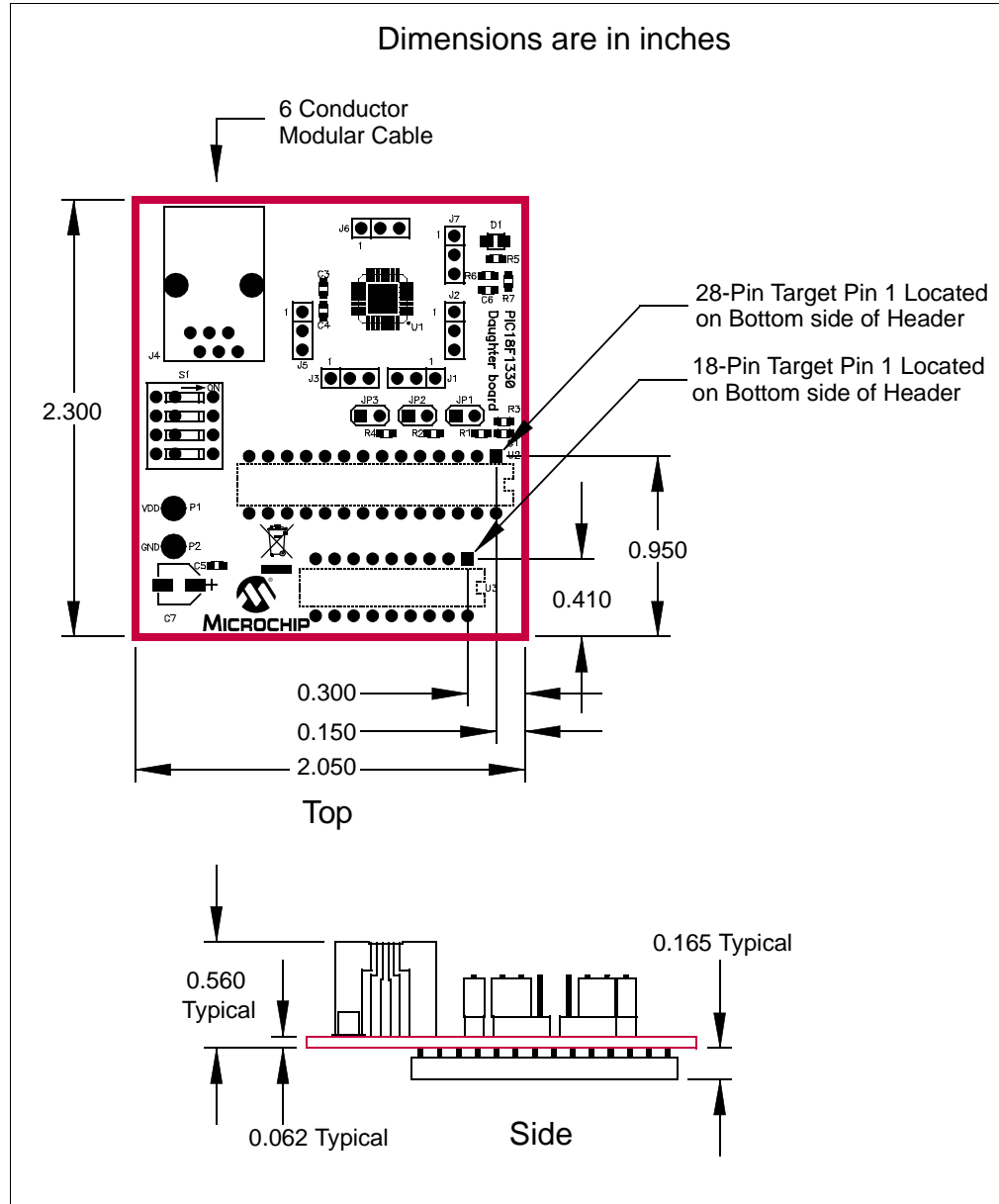

AC162088, AC162094

Header Identification

The header AC number is used for ordering the header. However, this number is not on the header board, as the board is often used for multiple headers by inserting different ICE/ICD devices. To identify this header board, use the following information.

Header	ICE/ICD Device	Board Assembly Number
AC162088	PIC24FJ64GA004-ICE	02-01979
AC162094		02-01982

Header Setup and Operation

Both 28-pin and 44-pin device headers have jumpers related to the enabling or disabling of the on-chip 2.5 volt voltage regulator. Please see the section entitled “On-Chip Voltage Regulator” in the “*dsPIC33F Family Reference Manual*” (DS70165) for more details.

Jumper J2	Function
1-2	Disable voltage regulator
2-3	Enable voltage regulator
No connection	DISVREG controlled by target

Test points are available on this header to check the following:

Test Point	Color	Signal	Test Point	Color	Signal
TP1	Black	Ground	TP5	White	DISVREG
TP2	Red	VDD	TP6	White	PGC
TP3	Black	AVSS	TP7	White	PGD
TP4	Red	AVDD	TP8	Yellow	$\overline{\text{ICRST}}$

Header Limitations

See the “Limitations” section in your debug tool on-line Help file for details.

Header Dimensions

The figures below list the dimensions for the header boards. Dimensions are design values in inches.

If the length and/or width of the header board is too large a footprint for the target board, consider using stand-offs, transition sockets or other extenders in the header connection socket to raise the header above the target.

Optional Headers

FIGURE 9: DIMENSIONS (28 PIN) – AC162088

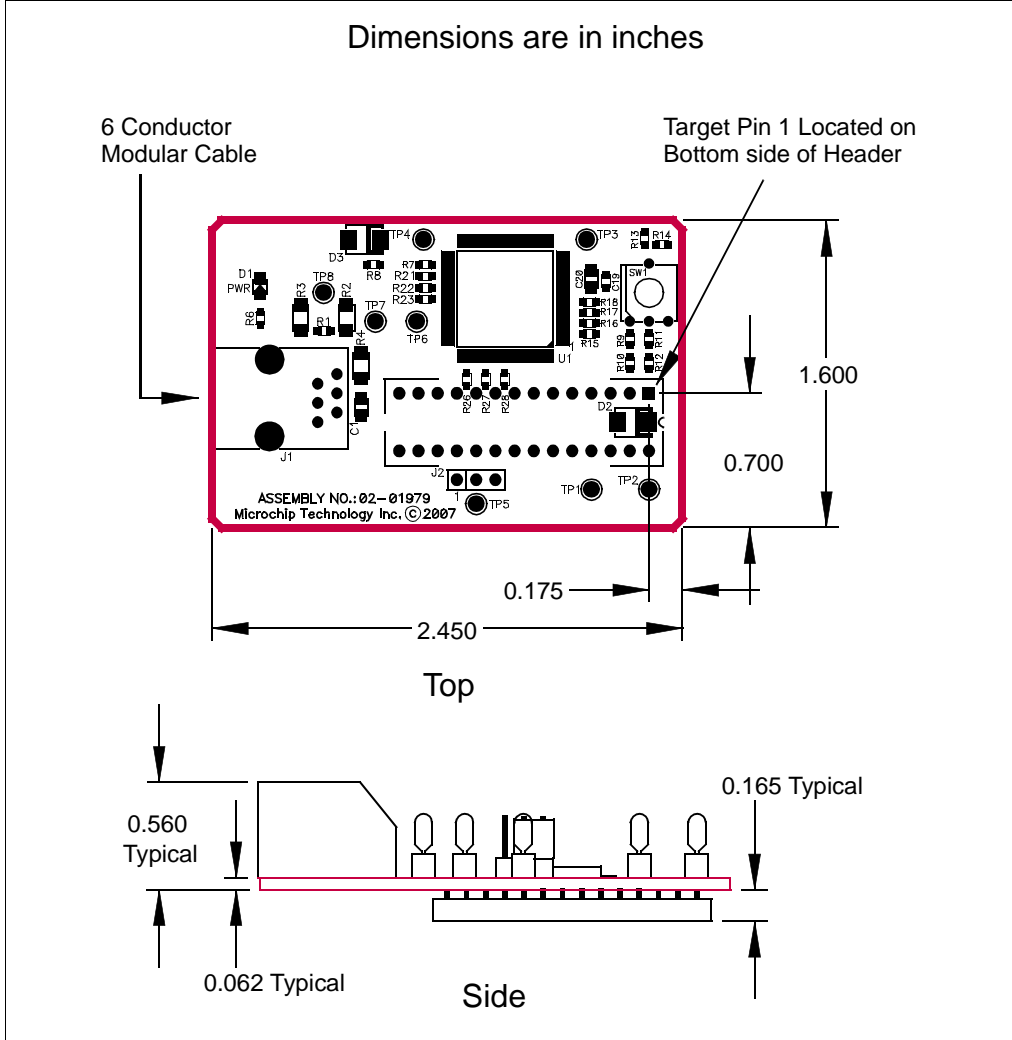
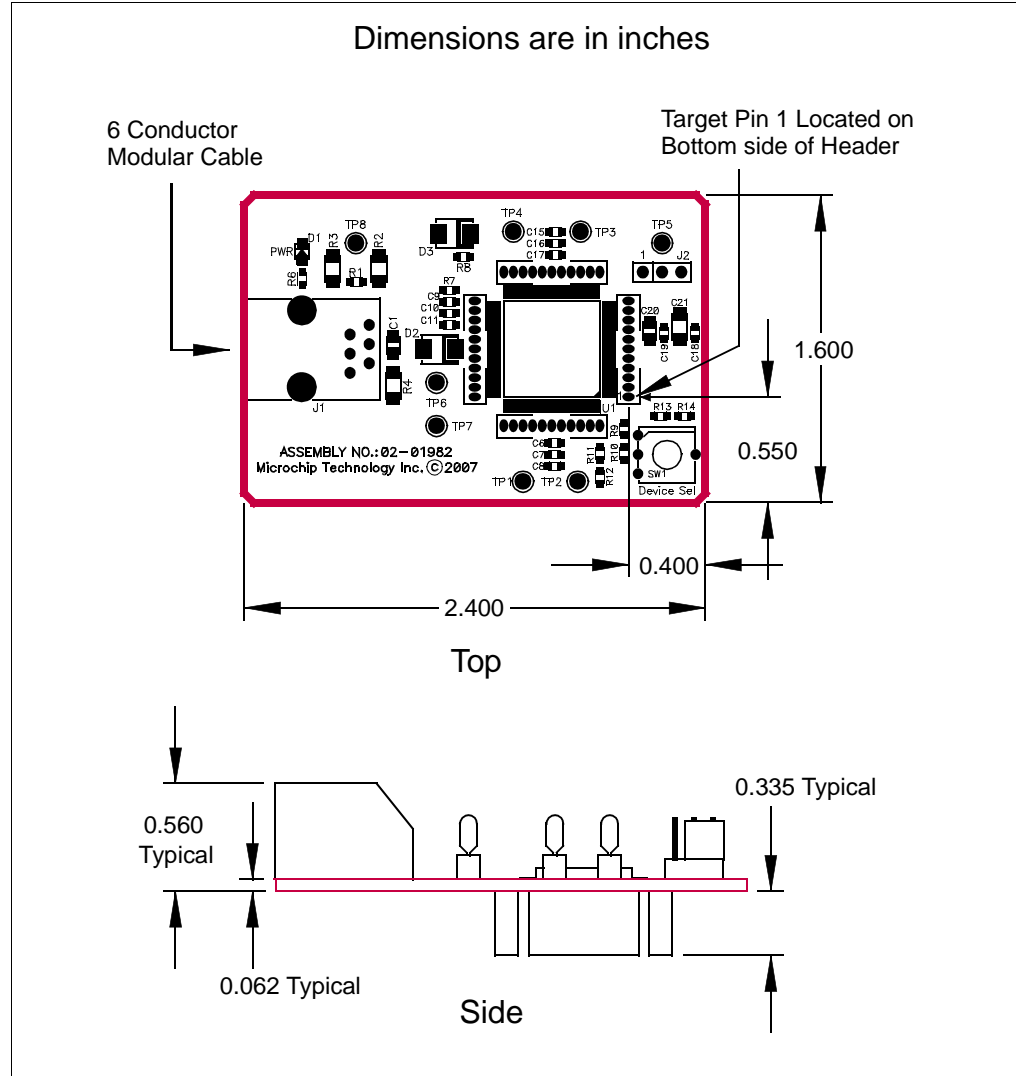

FIGURE 10: DIMENSIONS (44 PIN) – AC162094



Optional Headers

AC244026, AC244027

Header Identification

The header AC number is used for ordering the header. However, this number is not on the header board, as the board is often used for multiple headers by inserting different ICE/ICD devices. To identify this header board, use the following information.

Header	ICE/ICD Device	Board Assembly Number
AC244026	PIC16F727-ICE	02-02105
AC244027	PIC16LF727-ICE	

Header Setup and Operation - AC244026

This Processor Extension Pak provides extra debugging capability not available on PIC16F727 production devices:

- 3 Address / Data breakpoints (1 Address only breakpoint on production devices)
- Data capture (Real Time Data Streaming)
- No user Flash resources needed for debugging
- No user RAM resources needed for debugging
- No user pins required

This header has jumpers available for MCLR pull-up and power LED control.

Jumper	Setting	Function
J2	Open	Disable weak ICE $\overline{\text{MCLR}}$ pull-up resistor.
	Short	Enable weak ICE $\overline{\text{MCLR}}$ pull-up resistor. This option keeps the target program running even after the tool has been disconnected from the header, i.e., the pin will not float high.
J3	Open	Disable power LED indicator. This option saves power.
	Short	Enable power LED indicator.

Additionally, this header has jumpers related to the LDO voltage regulator. Depending on the device pin used for this function, you would use either J4 (RA0), J5 (RA5) or J6 (RA6) for Vcap selection. For details on the voltage regulator, see the "PIC16F72X/PIC16LF72X Data Sheet" (DS41341).

Jumper	Setting	Function
J4 or J5 or J6	Open	Use only target capacitance for VCAP. This is the standard configuration.
	Short	Use both on-board and target capacitance for VCAP. This option is to provide extra margin for the voltage regulator stability/regulation in cases where there is a long lead length between the emulation header VCAP pin and the target VCAP pin. (As examples, when using long-pin DIP transition sockets or certain QFN transition sockets.)

Test points are available on this header to check the following:

Test Point	Signal	Test Point	Signal	Pin	Jumper
TP1	V _{ss}	TP6	V _{cap}	RA0	J4
TP2	V _{DD}	TP7	V _{cap}	RA5	J5
TP3	$\overline{\text{ICD}}$ Enable	TP8	V _{cap}	RA6	J6
TP4	V _{DD}				
TP5	V _{ss}				

Header Setup and Operation - AC244027

This Processor Extension Pak provides extra debugging capability not available on PIC16LF727 production devices:

- 3 Address/Data breakpoints (1 Address only breakpoint on production devices)
- Data capture (Real Time Data Streaming)
- No user Flash resources needed for debugging
- No user RAM resources needed for debugging
- No user pins required

This header has jumpers available for MCLR pull-up and power LED control.

Jumper	Setting	Function
J2	Open	Disable weak ICE $\overline{\text{MCLR}}$ pull-up resistor.
	Short	Enable weak ICE $\overline{\text{MCLR}}$ pull-up resistor. This option keeps the target program running even after the tool has been disconnected from the header, i.e., the pin will not float high.
J3	Open	Disable power LED indicator. This option saves power.
	Short	Enable power LED indicator.

Test points are available on this header to check the following:

Test Point	Signal	Test Point	Signal
TP1	V _{ss}	TP4	V _{DD}
TP2	V _{DD}	TP5	V _{ss}
TP3	$\overline{\text{ICD}}$ Enable		

Header Limitations

See the “Limitations” section in your debug tool on-line Help file for details.

Header Dimensions

The figures below list the dimensions for the header boards. Dimensions are design values in inches.

If the length and/or width of the header board is too large a footprint for the target board, consider using stand-offs, transition sockets or other extenders in the header connection socket to raise the header above the target.

Optional Headers

FIGURE 11: DIMENSIONS – AC244026, AC244027

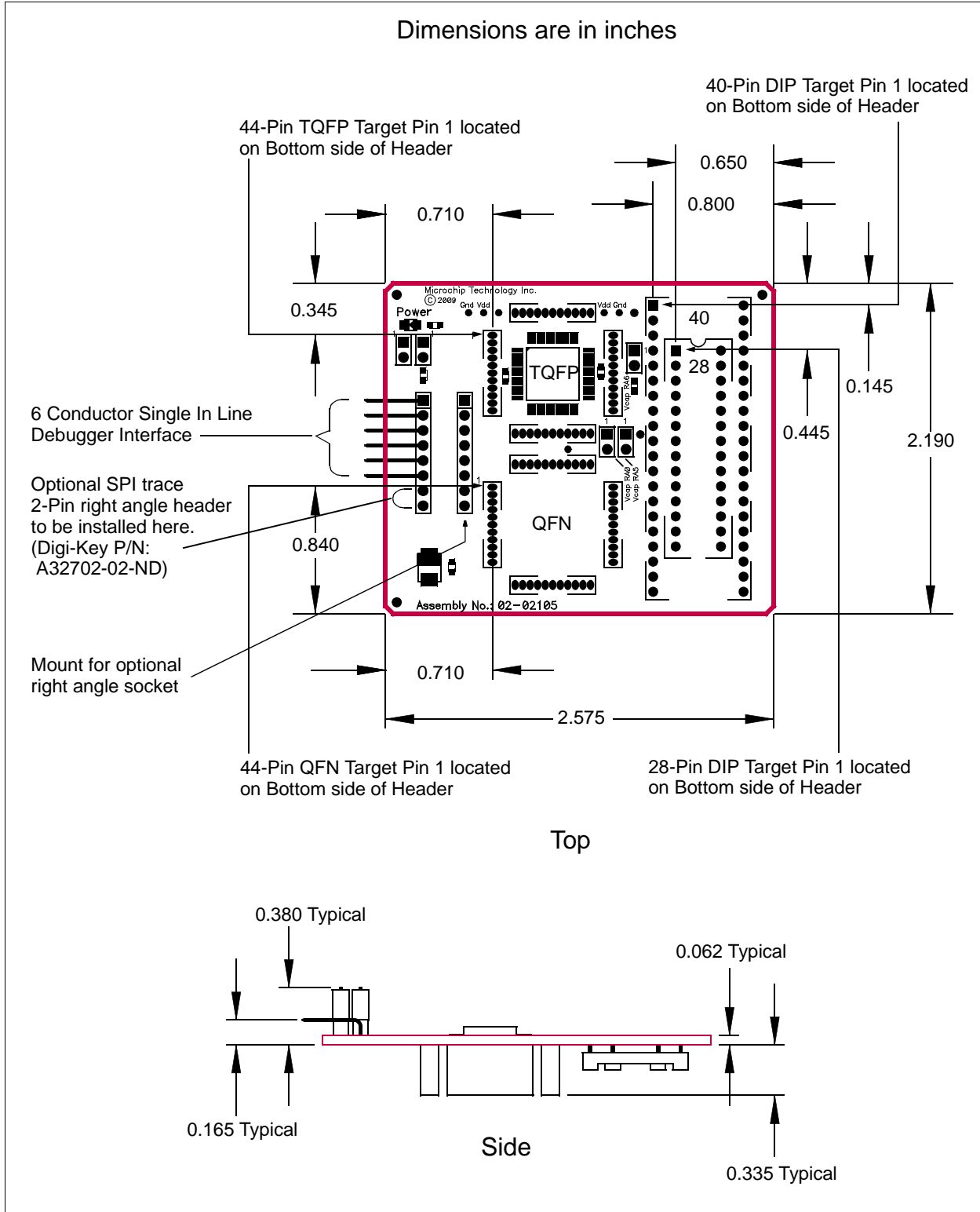

AC244033, AC244034

Header Identification

The header AC number is used for ordering the header. However, this number is not on the header board, as the board is often used for multiple headers by inserting different ICE/ICD devices. To identify this header board, use the following information.

Header	ICE/ICD Device	Board Assembly Number
AC244033	PIC18F14K22-ICE	02-02031
AC244034	PIC18LF14K22-ICE	

Header Setup and Operation

For this header, there are no jumpers/switches. MPLAB IDE will use its selected device to choose the correct device to emulate.

Header Limitations

See the "Limitations" section in your debug tool on-line Help file for details.

Header Dimensions

The figures below list the dimensions for the header boards. Dimensions are design values in inches.

If the length and/or width of the header board is too large a footprint for the target board, consider using stand-offs, transition sockets or other extenders in the header connection socket to raise the header above the target.

Optional Headers

FIGURE 12: DIMENSIONS (20 PIN) – AC244033, AC244034

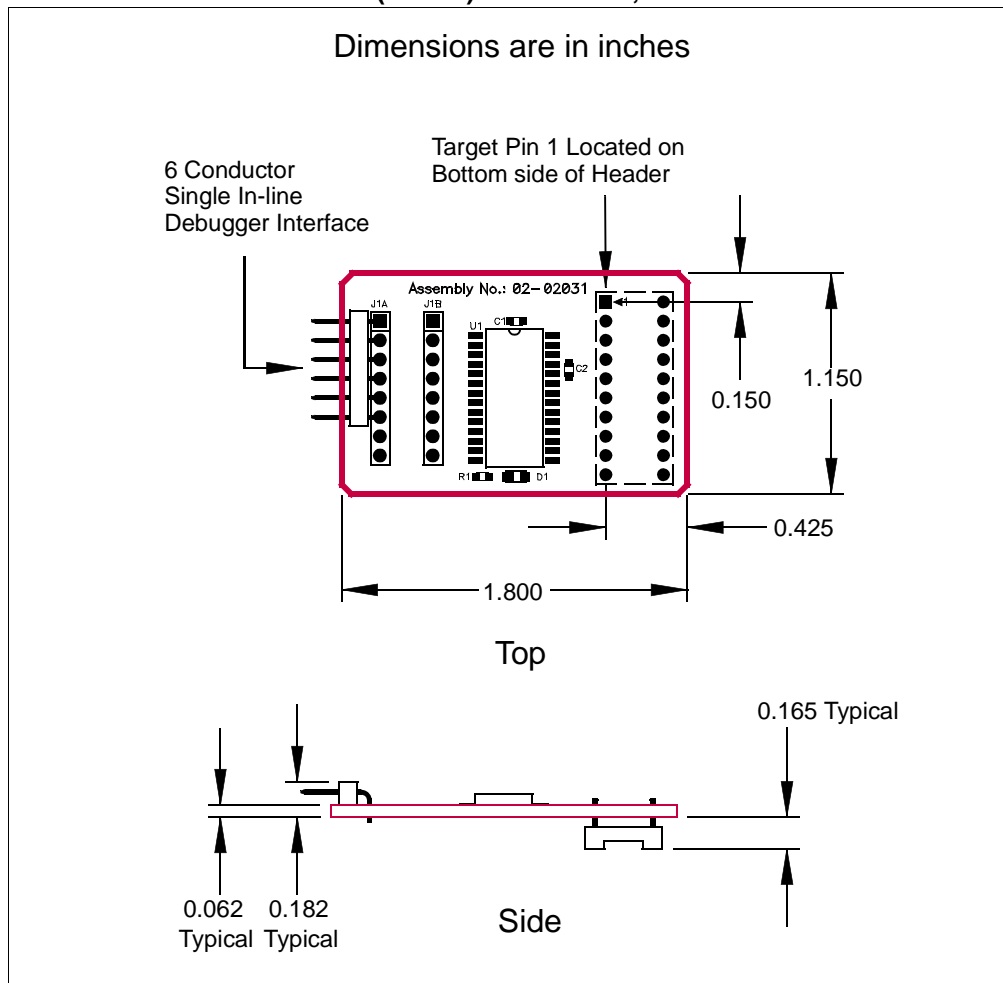

Appendix A. Header Target Footprints

To connect a header board directly to a target board (without the use of a transition socket) the following information will be helpful.

- DIP Device Footprints
- TQFP/PLCC Device Footprints

DIP DEVICE FOOTPRINTS

DIP device adapter footprints shown will accept adapter plugs like Samtec series APA plugs. These plugs can be soldered in place during development/emulation and eliminate the need for any other sockets.

FIGURE 13: DIP FOOTPRINT

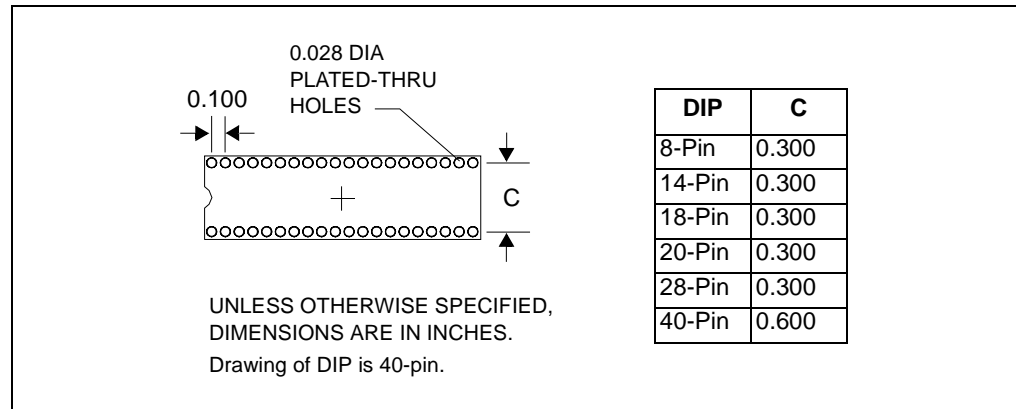

TQFP/PLCC DEVICE FOOTPRINTS

TQFP/PLCC device adapter footprints shown will accept board stackers like Samtec series DWM 0.050 Pitch Stackers. These stackers can be soldered in place during development/emulation and eliminate the need for any other sockets.

FIGURE 14: SINGLE-ROW TQFP/PLCC FOOTPRINT

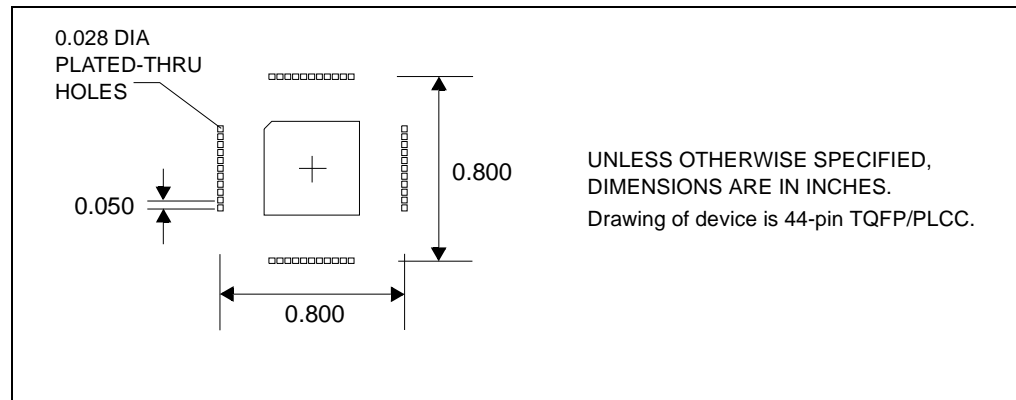
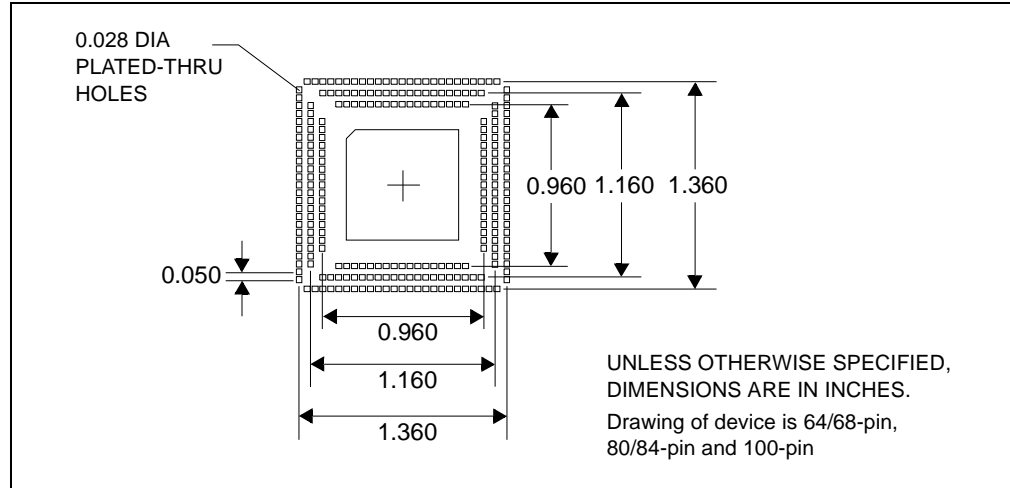

FIGURE 15: DOUBLE AND TRIPLE-ROW TQFP/PLCC FOOTPRINT



Header pin-out matches the PLCC package. PLCC will map to TQFP as follows:

- Header to 44-pin TQFP – one-to-one mapping.
- Header to 64-pin TQFP – see Figure 16 for mapping.
- Header to 80-pin TQFP – see Figure 17 for mapping.
- Header to 100-pin TQFP – one-to-one mapping.

FIGURE 16: HEADER TO 64-PIN TQFP

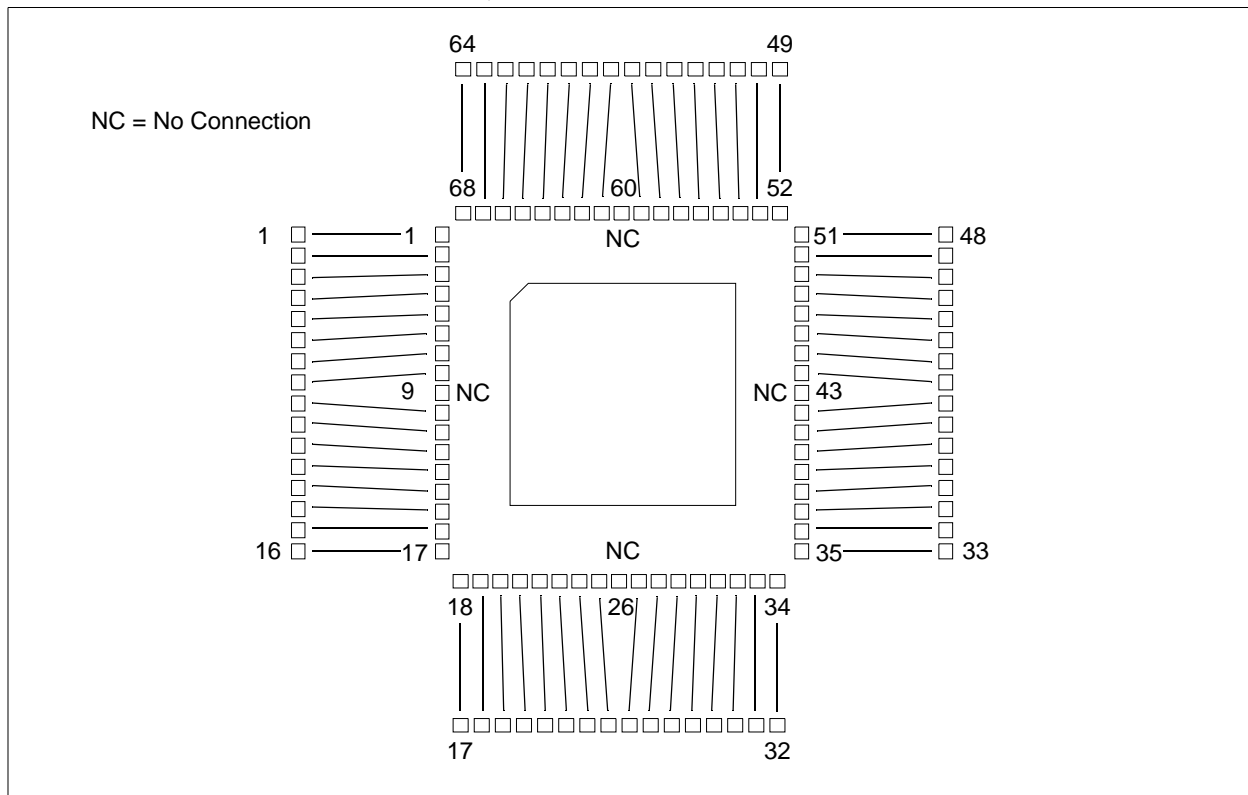
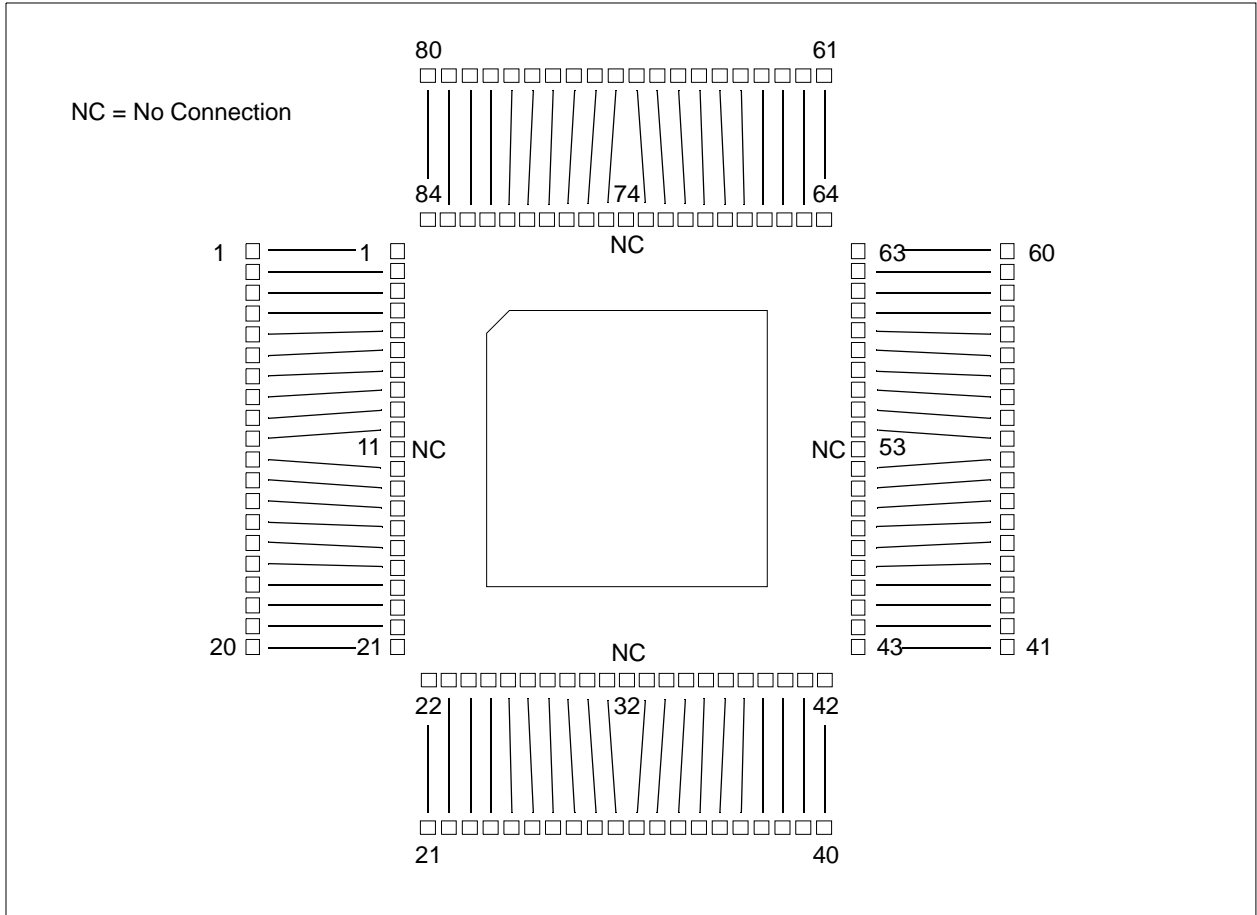

FIGURE 17: HEADER TO 80-PIN TQFP



NOTES:

Appendix B. Header Connections

The different types of header board connectors are shown here, as well as information on connecting development tools to the header.

- 6-Pin Modular Connector
- 8-Pin SIL Connector
- 6-Pin SIL Connector
- Modular-to-SIL Adapter
- Ordering Information

6-PIN MODULAR CONNECTOR

Header boards with 6-pin modular (RJ-11/ICSP) connectors can connect directly with the following tools:

- MPLAB REAL ICE in-circuit emulator (Standard Communication)
- MPLAB ICD 2 or 3

FIGURE 1: MODULAR CONNECTION

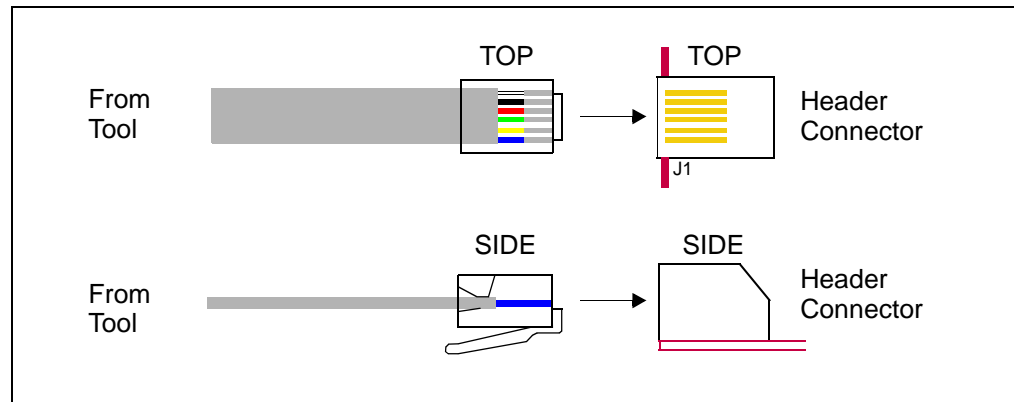

8-PIN SIL CONNECTOR

Header boards with 8-pin SIL (Single In-Line) connectors can connect directly with the following tools:

- MPLAB REAL ICE in-circuit emulator (High-Speed Communication) – line up pin 1 on board with pin 1 on header

Using the Modular-to-SIL Adapter, you can also connect to:

- MPLAB REAL ICE in-circuit emulator (Standard Communication)
- MPLAB ICD 2 or 3

FIGURE 2: 8-PIN SIL CONNECTION

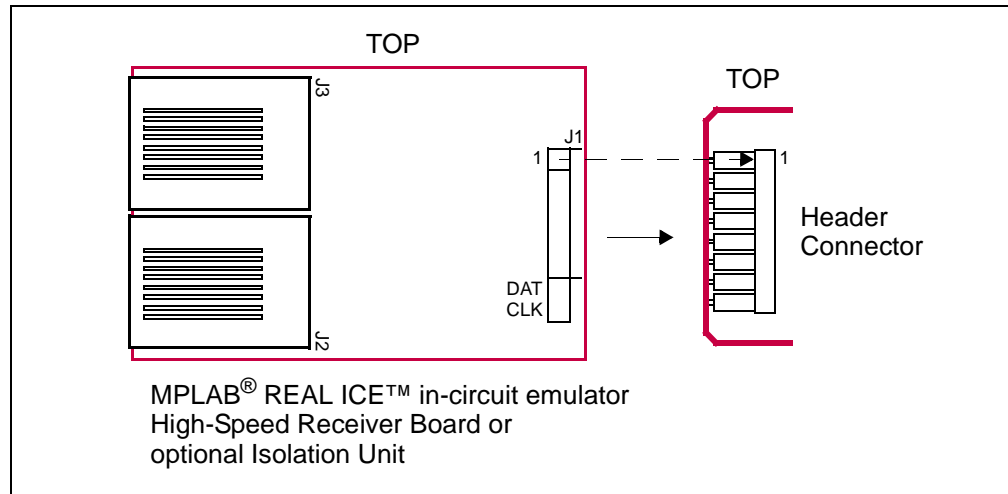

6-PIN SIL CONNECTOR

Header boards with 6-pin SIL (Single In-Line) connectors can connect directly with the following tools:

- MPLAB REAL ICE in-circuit emulator (High-Speed Communication) – line up pin 1 on board with pin 1 on header

Note: No SPI trace is possible in this case because of the loss of DAT and CLK pins.

- PICKit 2 or 3 Debug Express

Using the Modular-to-SIL Adapter, you can also connect to:

- MPLAB REAL ICE in-circuit emulator (Standard Communication)
- MPLAB ICD 2 or 3

FIGURE 3: 6-PIN SIL CONNECTION

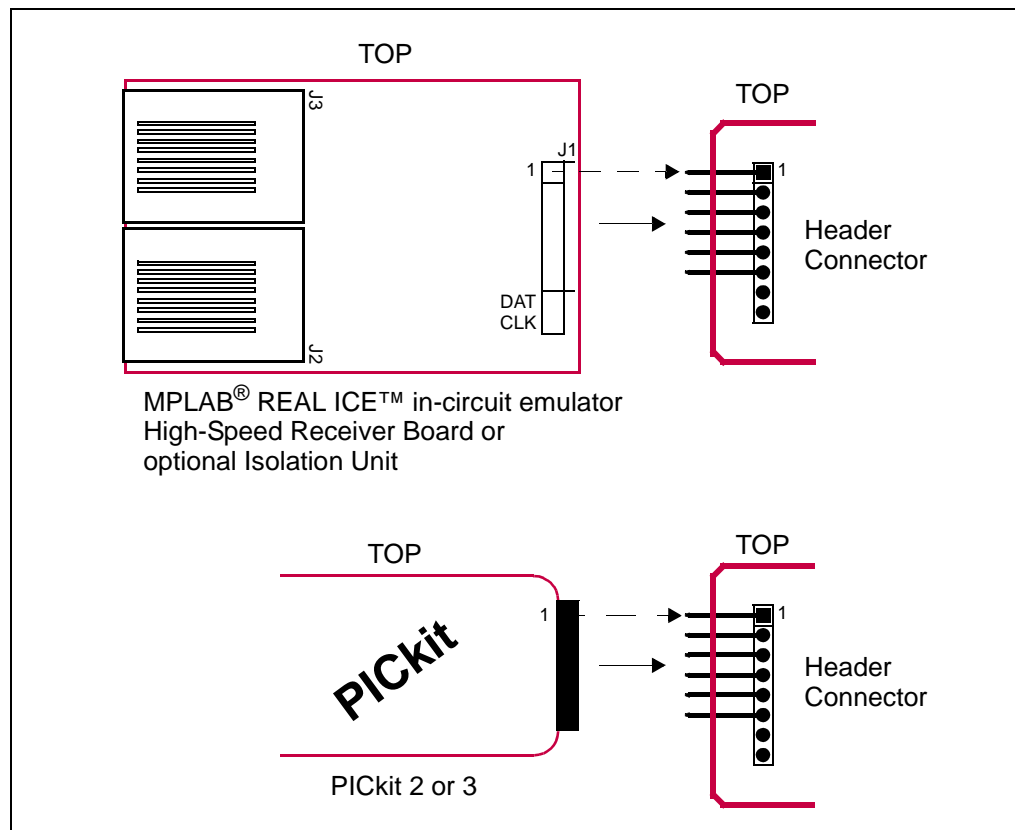

MODULAR-TO-SIL ADAPTER

To adapt a 6-pin modular connector to an 8-pin SIL (Single In-Line) connector, you can use this adapter. You can also use this adapter for a 6-pin modular connector to an 6-pin SIL connector. In either case, **line up pin 1 of J1 with pin 1** of the 6- or 8-pin header connector.

FIGURE 4: MODULAR-TO-SIL ADAPTER CONNECTION

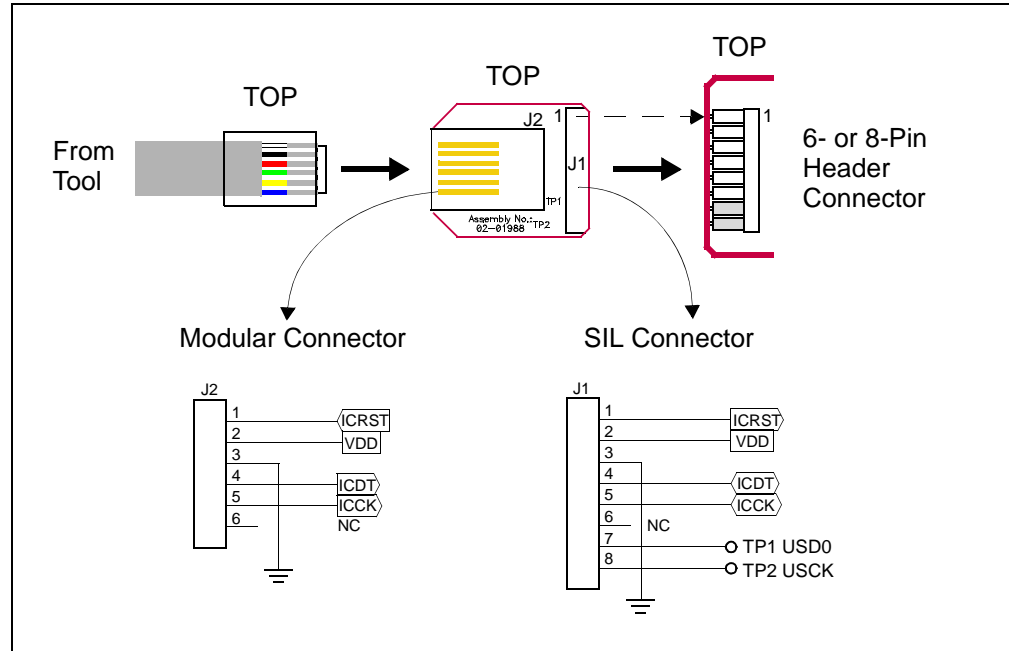

ORDERING INFORMATION

To order the development tools and other hardware shown here, please refer to the table below.

TABLE B-1: MICROCHIP HARDWARE ORDERING NUMBERS

Hardware	Order #
MPLAB [®] REAL ICE [™] in-circuit emulator (Standard Communication)	DV244005
MPLAB REAL ICE in-circuit emulator (High-Speed Communication) – Performance Pak	AC244002
MPLAB REAL ICE Isolation Unit (works with High-Speed Communication)	AC244005
MPLAB ICD 2	DV164005
MPLAB ICD 3	DV164035
PICkit [™] 2 Debug Express	DV164121
PICkit 3 Debug Express	DV164131
Modular-to-SIL Adapter	AC164110

APPENDIX C: REVISION HISTORY

C.1 Revision N (February 2006)

- Added Appendix A: Revision History
- Updated document to reflect support of additional tools
- Additional minor corrections throughout document text

C.2 Revision P (September 2007)

- Updated document to reflect support of additional tools
- Additional minor corrections throughout document text

C.3 Revision Q (December 2008)

- Added limitations to header setup sections as needed.
- Changed “ICD Headers” and “ICE Headers” to “Required Headers” and “Optional Headers” and move sections as necessary.
- Rearranged sections to organize by header (AC) number.

C.4 Revision R (April 2009)

- Added board dimensions
- Removed header pinouts
- Added board identification info
- Added “why use a header” section
- Added footprint appendix
- Changed MPLAB ICD 2 and MPLAB ICD 3 references to generic debug tool
- Added MPLAB REAL ICE in-circuit emulator and MPLAB ICD 3 as programmers

C.5 Revision S (July 2010)

- Added AC244028
- Added Header Connections chapter
- Added AC244033, AC244034
- Moved limitations to common Limitations file and added small section referencing Help files
- Added PIC12F617 to AC162083

Header Board Specification

NOTES:

Index

Numerics

6-Pin Modular Connector	57
6-Pin SIL Connector	59
8-Pin SIL Connector	58

A

AC162050	8
AC162052	10
AC162053	12
AC162054	12
AC162055	10
AC162056	10
AC162057	10
AC162058	8
AC162059	14
AC162060	16
AC162061	18
AC162062	32
AC162064	34
AC162065	36
AC162066	20
AC162067	39
AC162070	14
AC162074	39
AC162078	42
AC162079	32
AC162083	22
AC162087	32
AC162088	45
AC162091	32
AC162094	45
AC162096	14
AC244022	36
AC244023	24
AC244024	24
AC244026	48
AC244027	48
AC244028	26
AC244033	51
AC244034	51
Additional Information	5

C

Calibration Bits	5
------------------------	---

I

ICE vs. ICD	2
-------------------	---

J

Jumper Settings 8, 10, 16, 20, 26, 32, 39, 43, 45, 48, 49	
---	--

M

Modular Connector	57
Modular-to-SIL Adapter	60
MPLAB ICE 2000	20

O

Ordering Hardware	60
-------------------------	----

P

PCM16YM0	20
Performance	5
PIC10F200	7
PIC10F202	7
PIC10F204	7
PIC10F206	7
PIC10F220	7
PIC10F222	7
PIC12F508	7
PIC12F509	7
PIC12F510	7
PIC12F519	7
PIC12F609	7, 22
PIC12F615	7, 22
PIC12F617	7, 22
PIC12F629	7, 8
PIC12F635	7, 10
PIC12F675	7, 8
PIC12F683	7, 8
PIC12HV609	7, 22
PIC12HV615	7, 22
PIC16F505	7
PIC16F506	7
PIC16F526	7
PIC16F610	7, 22
PIC16F616	7, 22
PIC16F627A	7, 12
PIC16F628A	7, 12
PIC16F630	7, 10
PIC16F631	7, 18
PIC16F636	7, 10
PIC16F639	7, 20
PIC16F648A	7, 12
PIC16F676	7, 10
PIC16F677	7, 18
PIC16F684	7, 10
PIC16F685	7, 18
PIC16F687	7, 18
PIC16F688	7, 10
PIC16F689	7, 18
PIC16F690	7, 18
PIC16F716	8, 12
PIC16F785	8, 16

Header Board Specification

PIC16HV610	7, 22	PIC18F87J11	30
PIC16HV616	7, 22	PIC18F87J50	30
PIC16HV785	8, 16	PIC18F87J60	30
PIC18F1230	29, 42	PIC18F96J60	30
PIC18F1330	29, 42	PIC18F96J65	30
PIC18F13K22	29	PIC18F97J60	30
PIC18F13K50	8	PIC18LF13K22	29
PIC18F14K22	29	PIC18LF13K50	8
PIC18F14K50	8	PIC18LF14K22	29
PIC18F24J10	29	PIC18LF14K50	8
PIC18F25J10	29, 39	PIC18LF24J10	29
PIC18F44J10	29	PIC18LF25J10	29, 39
PIC18F45J10	29, 39	PIC18LF44J10	29
PIC18F63J11	30	PIC18LF45J10	29, 39
PIC18F63J90	30	PIC24F04KA200	8
PIC18F64J11	30	PIC24F04KA201	8
PIC18F64J16	30	PIC24F08KA101	31
PIC18F64J90	30	PIC24F08KA102	31
PIC18F64J95	30	PIC24F16KA101	31
PIC18F65J10	30	PIC24F16KA102	31
PIC18F65J11	30	PIC24FJ128GA006	31
PIC18F65J15	30	PIC24FJ128GA008	31
PIC18F65J16	30	PIC24FJ128GA010	31
PIC18F65J50	30	PIC24FJ16GA002	31
PIC18F65J55	30	PIC24FJ16GA004	31
PIC18F65J90	30	PIC24FJ32GA002	31
PIC18F66J10	30	PIC24FJ32GA004	31
PIC18F66J11	30	PIC24FJ48GA002	31
PIC18F66J15	30	PIC24FJ48GA004	31
PIC18F66J16	30	PIC24FJ64GA002	31
PIC18F66J50	30	PIC24FJ64GA004	31
PIC18F66J55	30	PIC24FJ64GA006	31
PIC18F66J60	30	PIC24FJ64GA008	31
PIC18F66J65	30	PIC24FJ64GA010	31
PIC18F67J10	30	PIC24FJ96GA006	31
PIC18F67J11	30	PIC24FJ96GA008	31
PIC18F67J50	30	PIC24FJ96GA010	31
PIC18F67J60	30	PICDEM HPC Explorer Board	32
PIC18F83J11	30	Pin Count	7, 29
PIC18F83J90	30	Programming Non-ICD Devices	3
PIC18F84J11	30	S	
PIC18F84J16	30	SIL Connector, 6 Pin	59
PIC18F84J90	30	SIL Connector, 8 Pin	58
PIC18F84J95	30	Switch Settings	18
PIC18F85J10	30	Switch Settings, Rotary	22
PIC18F85J11	30	T	
PIC18F85J15	30	Transition Socket	4
PIC18F85J16	30	V	
PIC18F85J50	30	Vdd Max	7, 29
PIC18F85J55	30	Vddcore Max	7, 29
PIC18F85J90	30		
PIC18F86J10	30		
PIC18F86J11	30		
PIC18F86J15	30		
PIC18F86J16	30		
PIC18F86J50	30		
PIC18F86J55	30		
PIC18F86J60	30		
PIC18F86J65	30		
PIC18F87J10	30		

Note the following details of the code protection feature on Microchip devices:

- Microchip products meet the specification contained in their particular Microchip Data Sheet.
- Microchip believes that its family of products is one of the most secure families of its kind on the market today, when used in the intended manner and under normal conditions.
- There are dishonest and possibly illegal methods used to breach the code protection feature. All of these methods, to our knowledge, require using the Microchip products in a manner outside the operating specifications contained in Microchip's Data Sheets. Most likely, the person doing so is engaged in theft of intellectual property.
- Microchip is willing to work with the customer who is concerned about the integrity of their code.
- Neither Microchip nor any other semiconductor manufacturer can guarantee the security of their code. Code protection does not mean that we are guaranteeing the product as “unbreakable.”

Code protection is constantly evolving. We at Microchip are committed to continuously improving the code protection features of our products. Attempts to break Microchip's code protection feature may be a violation of the Digital Millennium Copyright Act. If such acts allow unauthorized access to your software or other copyrighted work, you may have a right to sue for relief under that Act.

Information contained in this publication regarding device applications and the like is provided only for your convenience and may be superseded by updates. It is your responsibility to ensure that your application meets with your specifications. MICROCHIP MAKES NO REPRESENTATIONS OR WARRANTIES OF ANY KIND WHETHER EXPRESS OR IMPLIED, WRITTEN OR ORAL, STATUTORY OR OTHERWISE, RELATED TO THE INFORMATION, INCLUDING BUT NOT LIMITED TO ITS CONDITION, QUALITY, PERFORMANCE, MERCHANTABILITY OR FITNESS FOR PURPOSE. Microchip disclaims all liability arising from this information and its use. Use of Microchip devices in life support and/or safety applications is entirely at the buyer's risk, and the buyer agrees to defend, indemnify and hold harmless Microchip from any and all damages, claims, suits, or expenses resulting from such use. No licenses are conveyed, implicitly or otherwise, under any Microchip intellectual property rights.

Trademarks

The Microchip name and logo, the Microchip logo, dsPIC, KEELOQ, KEELOQ logo, MPLAB, PIC, PICmicro, PICSTART, PIC³² logo, rPIC and UNI/O are registered trademarks of Microchip Technology Incorporated in the U.S.A. and other countries.

FilterLab, Hampshire, HI-TECH C, Linear Active Thermistor, MXDEV, MXLAB, SEEVAL and The Embedded Control Solutions Company are registered trademarks of Microchip Technology Incorporated in the U.S.A.

Analog-for-the-Digital Age, Application Maestro, CodeGuard, dsPICDEM, dsPICDEM.net, dsPICworks, dsSPEAK, ECAN, ECONOMONITOR, FanSense, HI-TIDE, In-Circuit Serial Programming, ICSP, Mindi, MiWi, MPASM, MPLAB Certified logo, MPLIB, MPLINK, mTouch, Octopus, Omniscient Code Generation, PICC, PICC-18, PICDEM, PICDEM.net, PICkit, PICTail, REAL ICE, rLAB, Select Mode, Total Endurance, TSHARC, UniWinDriver, WiperLock and ZENA are trademarks of Microchip Technology Incorporated in the U.S.A. and other countries.

SQTP is a service mark of Microchip Technology Incorporated in the U.S.A.

All other trademarks mentioned herein are property of their respective companies.

© 2010, Microchip Technology Incorporated, Printed in the U.S.A., All Rights Reserved.

 Printed on recycled paper.

ISBN: 978-1-60932-377-6

Microchip received ISO/TS-16949:2002 certification for its worldwide headquarters, design and wafer fabrication facilities in Chandler and Tempe, Arizona; Gresham, Oregon and design centers in California and India. The Company's quality system processes and procedures are for its PIC® MCUs and dsPIC® DSCs, KEELOQ® code hopping devices, Serial EEPROMs, microperipherals, nonvolatile memory and analog products. In addition, Microchip's quality system for the design and manufacture of development systems is ISO 9001:2000 certified.

**QUALITY MANAGEMENT SYSTEM
CERTIFIED BY DNV
== ISO/TS 16949:2002 ==**



WORLDWIDE SALES AND SERVICE

AMERICAS

Corporate Office
2355 West Chandler Blvd.
Chandler, AZ 85224-6199
Tel: 480-792-7200
Fax: 480-792-7277
Technical Support:
<http://support.microchip.com>
Web Address:
www.microchip.com

Atlanta
Duluth, GA
Tel: 678-957-9614
Fax: 678-957-1455

Boston
Westborough, MA
Tel: 774-760-0087
Fax: 774-760-0088

Chicago
Itasca, IL
Tel: 630-285-0071
Fax: 630-285-0075

Cleveland
Independence, OH
Tel: 216-447-0464
Fax: 216-447-0643

Dallas
Addison, TX
Tel: 972-818-7423
Fax: 972-818-2924

Detroit
Farmington Hills, MI
Tel: 248-538-2250
Fax: 248-538-2260

Kokomo
Kokomo, IN
Tel: 765-864-8360
Fax: 765-864-8387

Los Angeles
Mission Viejo, CA
Tel: 949-462-9523
Fax: 949-462-9608

Santa Clara
Santa Clara, CA
Tel: 408-961-6444
Fax: 408-961-6445

Toronto
Mississauga, Ontario,
Canada
Tel: 905-673-0699
Fax: 905-673-6509

ASIA/PACIFIC

Asia Pacific Office
Suites 3707-14, 37th Floor
Tower 6, The Gateway
Harbour City, Kowloon
Hong Kong
Tel: 852-2401-1200
Fax: 852-2401-3431

Australia - Sydney
Tel: 61-2-9868-6733
Fax: 61-2-9868-6755

China - Beijing
Tel: 86-10-8528-2100
Fax: 86-10-8528-2104

China - Chengdu
Tel: 86-28-8665-5511
Fax: 86-28-8665-7889

China - Chongqing
Tel: 86-23-8980-9588
Fax: 86-23-8980-9500

China - Hong Kong SAR
Tel: 852-2401-1200
Fax: 852-2401-3431

China - Nanjing
Tel: 86-25-8473-2460
Fax: 86-25-8473-2470

China - Qingdao
Tel: 86-532-8502-7355
Fax: 86-532-8502-7205

China - Shanghai
Tel: 86-21-5407-5533
Fax: 86-21-5407-5066

China - Shenyang
Tel: 86-24-2334-2829
Fax: 86-24-2334-2393

China - Shenzhen
Tel: 86-755-8203-2660
Fax: 86-755-8203-1760

China - Wuhan
Tel: 86-27-5980-5300
Fax: 86-27-5980-5118

China - Xian
Tel: 86-29-8833-7252
Fax: 86-29-8833-7256

China - Xiamen
Tel: 86-592-2388138
Fax: 86-592-2388130

China - Zhuhai
Tel: 86-756-3210040
Fax: 86-756-3210049

ASIA/PACIFIC

India - Bangalore
Tel: 91-80-3090-4444
Fax: 91-80-3090-4123

India - New Delhi
Tel: 91-11-4160-8631
Fax: 91-11-4160-8632

India - Pune
Tel: 91-20-2566-1512
Fax: 91-20-2566-1513

Japan - Yokohama
Tel: 81-45-471- 6166
Fax: 81-45-471-6122

Korea - Daegu
Tel: 82-53-744-4301
Fax: 82-53-744-4302

Korea - Seoul
Tel: 82-2-554-7200
Fax: 82-2-558-5932 or
82-2-558-5934

Malaysia - Kuala Lumpur
Tel: 60-3-6201-9857
Fax: 60-3-6201-9859

Malaysia - Penang
Tel: 60-4-227-8870
Fax: 60-4-227-4068

Philippines - Manila
Tel: 63-2-634-9065
Fax: 63-2-634-9069

Singapore
Tel: 65-6334-8870
Fax: 65-6334-8850

Taiwan - Hsin Chu
Tel: 886-3-6578-300
Fax: 886-3-6578-370

Taiwan - Kaohsiung
Tel: 886-7-536-4818
Fax: 886-7-536-4803

Taiwan - Taipei
Tel: 886-2-2500-6610
Fax: 886-2-2508-0102

Thailand - Bangkok
Tel: 66-2-694-1351
Fax: 66-2-694-1350

EUROPE

Austria - Wels
Tel: 43-7242-2244-39
Fax: 43-7242-2244-393

Denmark - Copenhagen
Tel: 45-4450-2828
Fax: 45-4485-2829

France - Paris
Tel: 33-1-69-53-63-20
Fax: 33-1-69-30-90-79

Germany - Munich
Tel: 49-89-627-144-0
Fax: 49-89-627-144-44

Italy - Milan
Tel: 39-0331-742611
Fax: 39-0331-466781

Netherlands - Drunen
Tel: 31-416-690399
Fax: 31-416-690340

Spain - Madrid
Tel: 34-91-708-08-90
Fax: 34-91-708-08-91

UK - Wokingham
Tel: 44-118-921-5869
Fax: 44-118-921-5820



**Стандарт
Электрон
Связь**

Мы молодая и активно развивающаяся компания в области поставок электронных компонентов. Мы поставляем электронные компоненты отечественного и импортного производства напрямую от производителей и с крупнейших складов мира.

Благодаря сотрудничеству с мировыми поставщиками мы осуществляем комплексные и плановые поставки широчайшего спектра электронных компонентов.

Собственная эффективная логистика и склад в обеспечивает надежную поставку продукции в точно указанные сроки по всей России.

Мы осуществляем техническую поддержку нашим клиентам и предпродажную проверку качества продукции. На все поставляемые продукты мы предоставляем гарантию .

Осуществляем поставки продукции под контролем ВП МО РФ на предприятия военно-промышленного комплекса России , а также работаем в рамках 275 ФЗ с открытием отдельных счетов в уполномоченном банке. Система менеджмента качества компании соответствует требованиям ГОСТ ISO 9001.

Минимальные сроки поставки, гибкие цены, неограниченный ассортимент и индивидуальный подход к клиентам являются основой для выстраивания долгосрочного и эффективного сотрудничества с предприятиями радиоэлектронной промышленности, предприятиями ВПК и научно-исследовательскими институтами России.

С нами вы становитесь еще успешнее!

Наши контакты:

Телефон: +7 812 627 14 35

Электронная почта: sales@st-electron.ru

Адрес: 198099, Санкт-Петербург,
Промышленная ул, дом № 19, литера Н,
помещение 100-Н Офис 331