



austriamicrosystems AG

is now

ams AG

The technical content of this austriamicrosystems datasheet is still valid.

Contact information:

Headquarters:

ams AG
Tobelbaderstrasse 30
8141 Unterpremstaetten, Austria
Tel: +43 (0) 3136 500 0
e-Mail: ams_sales@ams.com

Please visit our website at www.ams.com

Single-Chip Handsfree Phone
CMOS Integrated Circuit
AS2525

Key Features

- Line/speech handsfree circuit, LD/MF repertory dialler, and tone ringer on one 44 pin CMOS chip
- Operating range from 15 to 100 mA line current (down to 5 mA with slightly reduced performance)
- All significant parameters programmable with external EEPROM
- Volume control of receiver signal
- Handsfree function with enhanced voice switching
- Low noise (max. -72 dBmp)
- Unique EMC performance
- LD/MF switchable dialing with temporary MF mode
- Repertory dialing with last number redial and memory dialing (8 x 2 direct and 12 indirect)
- Call restriction with PIN code
- Serial interface for EEPROM and LCD driver
- 2-tone/3-tone ringer with ring frequency detection

General Description

The AS2525 is a CMOS mixed-mode integrated circuit for use in feature phones, answering machines and fax machines. It contains an analogue line interface and speech circuit for a/b terminals, loudhearing, handsfree, enhanced LD/MF dialler, tone ringer with dc/dc converter and serial interface to EEPROM and LCD-driver (AS2591), all in a 44 pin package. The circuit is fully line powered.

The AS2525 uses an external EEPROM for a 32 digit last number redial storage and memories for 28 numbers each containing up to 24 digits/data.

The device provides a volume control for the earpiece and the loudspeaker. The volume can be controlled by pressing the [V-]/[V+] keys.

The versatility of the circuit is provided by programming all parameters through an external EEPROM. This allows easy adaptation to various PTT requirements worldwide.

Package

Available in 44 pin TQFP.

Block Diagram

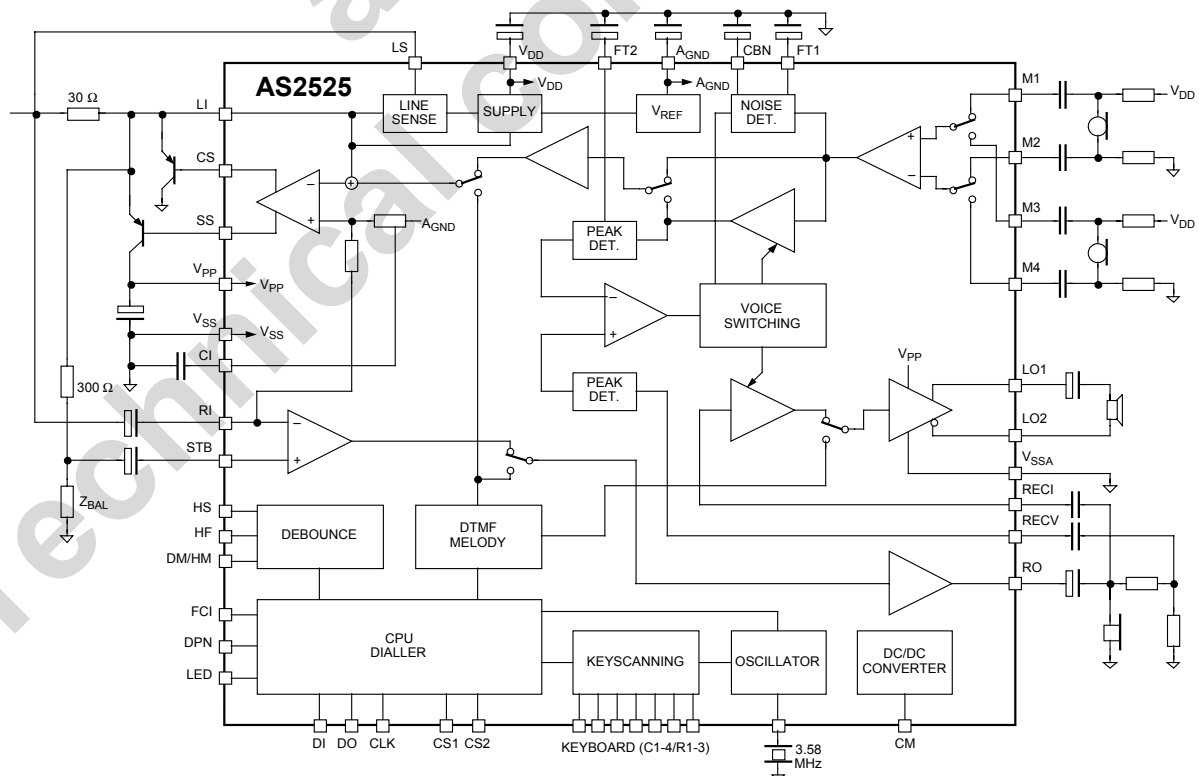

Pin Description

Pin #	Symbol	Type	Description
1	CS2	DO	Chip Select 2 Chip select signal for external LCD driver circuit or 2 mA LED If signal is not activated, a pull down resistor (100 kΩ) is inserted.
2	DPn	DO	Dial Pulse Output Digital output that holds the line during off-hook operation or pulls low during break periods of pulse dialing and flash.
3	HF	DI	HandsFree Switch Input This is a Schmitt-trigger input that is pulled high to enable handsfree operation.
4	HS	DI	HandSet Switch Input This is a Schmitt-trigger input that is pulled high by the hook switch to enable handset or headset operation.
5	FT1	AI	Analogue input pin for connecting a capacitor for offset cancellation.
6	FT2	AI	Analogue input pin for connecting a capacitor for offset cancellation.
7	M4	AI	Microphone Input 4 Differential input for the handsfree microphone (electret).
8	M2	AI	Microphone Input 2 Differential input for the handset microphone (electret).
9	M3	AI	Microphone Input 3 Differential input for the handsfree microphone (electret).
10	M1	AI	Microphone Input 1 Differential input for the handset microphone (electret).
11	STB	AI	Side Tone Balance Input Analogue input for side tone cancellation network.
12	CS	AO	Current Shunt Control Output N-channel open drain output to control the external high power shunt transistor for synthesizing ac- and dc-impedance, modulation of line voltage and shorting the line during make periods of pulse dialing.
13	V _{SS}	Supply	Voltage Source Source Negative Power Supply.
14	LI	AI	Line Input Analogue input used for power extraction and line current sensing.
15	RI	AI	Receive Input Analogue input for ac-separated receive signal.
16	SS	AO	Supply Source Control Output N-channel open drain output to control the external high power source transistor for supplying (V _{pp}) the loudspeaker amplifier in off-hook loudspeaking/handsfree mode.
17	LS	AI	Line Current Sense Input Analogue input for sensing the line current.
18	CI	AI	Complex Impedance Input Analogue input pin for the capacitor to program a complex impedance.

Pin #	Symbol	Type	Description
19	RECI	AI	RECEive Input Analogue input for the handsfree receive path. Should be connected to RO via a coupling capacitor.
20	RECV	AI	RECEive Voice Switching Input Analogue input for receive voice switching path.
21	RO	AO	Receive Output to Handset Output for driving a dynamic earpiece with an impedance from 150 Ω to 300 Ω .
22	V _{DD}	Supply	Voltage Drain Drain Positive Power Supply.
23	AGND	Supply	Analogue Ground Special ground for the internal amplifiers.
24	CBN	AI	Analogue input pin for connecting a capacitor for background noise monitoring.
25	CM	DO	Converter Make Output This is an output for controlling the external switching converter. During ringing it converts the ring signal into a 4V supply voltage.
26	V _{PP}	Supply	Loudspeaker Power Supply High power supply for the output driver stage.
27 28	LO1 LO2	AO	Loudspeaker Outputs 1/2 Output pins for a 32 Ω (25 to 50 Ω) loudspeaker.
29	V _{SSA}	Supply	Power supply pin for LO1-LO2 output amplifier.
30	DM/HM	DI	Dial Mode/Headset Mode Switch Input Digital input for choosing between LD and MF dialing or choosing handset and headset mode. See "Table 3: Parameter settings" for further details. This pin is scanned after manual off-hook only.
31	FCI	DI	Frequency Comparator Input This is a Schmitt-trigger input for ring frequency discrimination. Disabled during off-hook.
32	LED	DO	LED Output Digital output for connecting 2 mA LED to indicate handsfree mode.
33	OSC		OSCillator Input Input for ceramic resonator 3.58 MHz.
34 35 36	R1 R2 R3	DI/O	Keyboard Rows (see Figure 1: Keyboard Layout).
37 38 39 40	C1 C2 C3 C4	DI/O	Keyboard Columns (see Figure 1: Keyboard Layout).
41	CLK	DO	Clock Clock output for 3-wire bus. If signal is not activated, a pull down resistor (100 k Ω) is inserted.
42	DI	DI	Data Input Data input of 3-wire bus. If signal is not activated, a pull down resistor (100 k Ω) is inserted.

Pin #	Symbol	Type	Description
43	DO	DO	Data Output Data output of 3-wire bus. A 100 kΩ resistor connected from this pin to VSS enables key locking. If signal is not activated, a pull down resistor (100 kΩ) is inserted.
44	CS1	DO	Chip Select 1 Chip select signal for external EEPROM. If signal is not activated, a pull down resistor (100 kΩ) is inserted.

DI: Digital Input
 DO: Digital Output
 DI/O: Digital Input/Output

AI: Analogue Input
 AO: Analogue Output
 AI/O: Analogue Input/output

Basic Definitions

Password is set to 0123 and is used to access basic parameter settings (see Table 3: Parameter settings). The set-up programming is normally done in the factory during manufacturing of the telephone sets. The factory settings can be loaded into the EEPROM (see Figure 3: Memory allocation for external EEPROM).

PIN code is default set to 1111 and is used by the user to protect certain user settings (see Table 5: User programming with PIN code). The PIN code can be changed by the user.

Default settings are shown in **bold**.

Program procedures are entered with the [PG] key. Pressing any invalid key or going on-hook during programming will abort the program mode and no changes will be stored. Ending a program procedure by pressing the [PG] key will store the changes and exit the program mode.

Keyboard Layout

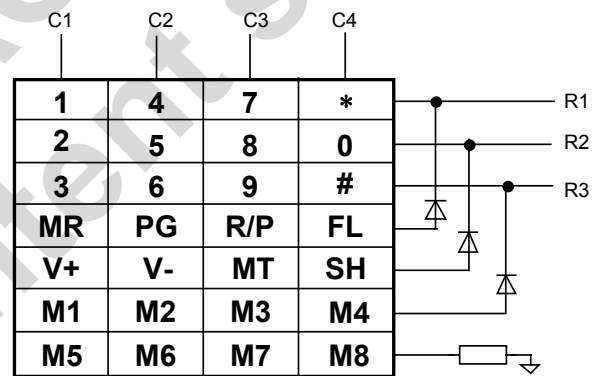

Figure 1: Keyboard Layout

Maximum R_{ON} for key closure: 1 kΩ

Minimum R_{OFF} for open key: 1 MΩ

See "Table 1: Key definitions" for description of key functions

Key Definitions and Procedures

Table 1: Key definitions

Key	Condition	Function	Remark
[0] - [9], [#], [*]	Off-hook	Digits	Function depending on mode
[*]	LD mode	Temporary MF select	Providing mixed mode dialing (default LD selected)
[PG]	Speech mode	Enter program state	To enter the program state
	Program mode	Exit program state	To terminate/exit program state
[MT]	Speech mode	Enter mute state	To enter mute state
	Mute state	Exit mute state	To terminate/exit mute state
	Program mode	Enter blank	To enter blank digit during programming
[R/P]		Redial/Pause	Allows re-signaling of the last dialed number and insertion of pauses
	Program state	Pause	Each key pressure inserts a pause
[FL]		Flash function	Invokes a timed loop break
[V+]	Speech mode	Volume control	To increase the receive gain
[V-]	Speech mode	Volume control	To increase or decrease the receive gain
[MR]		Memory redial key	To access memory by key codes
[M1] - [M8]		Memory dial	Access keys to memories 1 to 8 and 9 to 16
[SH]		Second function (shift)	To access second function of keys

Table 2: Digits

Digit Key	DTMF Mode ($f_{LOW} + f_{HIGH}$)	Pulse Mode	Programming Mode ([PG] + Digit)	Memory Location ([MR] + Digit)
[0]	941 + 1336 Hz	10 pulses		Memory 17
[1]	697 + 1209 Hz	1 pulse	To enter PIN protected programming	Memory 18
[2]	697 + 1336 Hz	2 pulses	Select flash duration	Memory 19
[3]	697 + 1477 Hz	3 pulses	Select dialing mode	Memory 20
[4]	770 + 1209 Hz	4 pulses	Select pause duration	Memory 21
[5]	770 + 1336 Hz	5 pulses	Key lock toggle	Memory 22
[6]	770 + 1477 Hz	6 pulses	Ringer volume	Memory 23
[7]	852 + 1209 Hz	7 pulses	Ringer melody	Memory 24
[8]	852 + 1336 Hz	8 pulses	LCD contrast	Memory 25
[9]	852 + 1477 Hz	9 pulses	Ringer on/off	Memory 26
[*]	941 + 1209 Hz	Temporary MF select		-
[#]	941 + 1477 Hz	-		-

Table 3: Parameter settings

Parameter	Symbol	Procedure: [PG] + [0] + (Password) +	Default	Options
Inter-Digit Pause (LD)	IDP	[*] + [1] + [HEX code]	840 ms	1.72 ms ... 7.03 sec. (see Table 4)
MF Tone Duration	TD	[*] + [2] + [HEX code]	82 ms	1.72 ms ... 7.03 sec. (see Table 4)
MF Inter-Tone Pause	ITP	[*] + [3] + [HEX code]	82 ms	1.72 ms ... 7.03 sec. (see Table 4)
Flash 1 Duration	FL1	[*] + [4] + [HEX code]	101 ms	1.72 ms ... 7.03 sec. (see Table 4)
Flash 2 Duration	FL2	[*] + [5] + [HEX code]	285 ms	1.72 ms ... 7.03 sec. (see Table 4)
Pause 1 Duration	P1	[*] + [6] + [HEX code]	1 second	1.72 ms ... 7.03 sec. (see Table 4)
Pause 2 Duration	P2	[*] + [7] + [HEX code]	3 seconds	1.72 ms ... 7.03 sec. (see Table 4)
Pre-Digit Pause (LD)	PDP	[*] + [8] + [HEX code]	33 ms	1.72 ms ... 7.03 sec. (see Table 4)
Post Flash Pause	PFP	[*] + [9] + [HEX code]	274 ms	1.72 ms ... 7.03 sec. (see Table 4)
Tx Gain, Handset	ATX-HS	[0] + [1] + [HEX code]	37 dB	30 to 45 dB (see Table 8)
Rx Gain, Handset	ARX-HS	[0] + [2] + [HEX code]	1 dB	-6 to 9 dB (see Table 12)
Tx Gain, Handsfree	ATX-HF	[0] + [3] + [HEX code]	46 dB	39 to 54 dB (see Table 10)
Rx Gain, Loudspeaker	ARX-HS	[0] + [4] + [HEX code]	29 dB	22 to 37 dB (see Table 14)
Line Loss Compensation	LLC	[0] + [5] +	[0] = off	[1] = range 1: I _{LINE} = 20 - 50 mA [2] = range 2: I _{LINE} = 45 - 75 mA
DTMF Level (Low Group)	V _{MF}	[0] + [6] + [HEX code]	-6 dBm	-18 to -6 dBm in 1 dB steps (see Table 24)
Tx Gain, Headset	ATX-HEAD	[0] + [7] + [HEX code]	37 dB	30 to 45 dB (see Table 20)
Rx Gain, Headset	ARX-HEAD	[0] + [8] + [HEX code]	1 dB	-6 to 9 dB (see Table 21)
MF Comfort Tone, RO	V _{MF-CT/RO}	[0] + [9] + [HEX code]	-30 dBr	-36 to -18 dBr in 6 dB steps (see Table 30)
MF Comfort Tone, LO1/2	V _{MF-CT/LO}	[0] + [0] + [HEX code]	-9 dBr	-15 to 3 dBr in 6 dB steps (see Table 30)
Make/Break Ratio (LD)	M/B	[#] + [1] +	[1] = 2 : 3	[0] = 1 : 2
Dial Rate (LD)	DR	[#] + [2] +	[0] = 10 pps	[1] = 20 pps
DC Mask (LI Voltage)	V _{LI}	[#] + [3] +	[1] = 4.5 Volt	[0] = 3.5 Volt
Tx Soft Clip (Handset)		[#] + [4] +	[1] = on (2 V _{PEAK})	[0] = off
Rx Soft Clip (Handset)		[#] + [5] +	[1] = on (1 V _{PEAK})	[0] = off
Noise Monitoring (HF)		[#] + [6] +	[1] = on	[0] = off
Loudhearing Mode		[#] + [7] +	[1] = HF only	[0] = LH and HF modes available
Ringer Melody		[#] + [8] +	[1] = 3-Tone	[0] = 2-Tone
Key-in Tone (Beep)	KT	[#] + [9] +	[1] = on	[0] = off
Reset PIN Code		[#] + [0] +	[1] = 1111	Selected by user

Parameter	Symbol	Procedure: [PG] + [0] + (Password) +	Default	Options
Flash 1 During LD		[#] + [*] +	[1] = on	[0] = off
Flash 2 During LD		[#] + [#] +	[0] = off	[1] = on
Extended LCD Symbols		[9] + [1] +	[0] = off	[1] = on
Tx Soft Clip, Handsfree		[9] + [2] +	[1] = on	[0] = off
Rx Soft Clip, Handsfree		[9] + [3] +	[1] = on	[0] = off
Voice Switching, Speed		[9] + [4] +	[1] = x 2	[0]=x1 (slow); [2]=x4; [3]=x8 (fast)
Handset/Headset Volume		[9] + [5] +	[1] = reset by on/off-hook	[0] = setting is maintained
LCD Test		[9] + [6]	Turns on all segments, pressing any further key turns on all digits "1" and all symbols off.	
Temporary MF by * with tone		[9] + [7] +	[0] = off	[1] = on
Key Lock Function		[9] + [8] +	[1] = available	[0] = not available
Pin Select "DM/HM"	DM/HM	[9] + [9] +	[1] = MF/LD	[0] = Handset/Headset
Ringer Off Function		[9] + [0] +	[1] = available	[0] = not available
Key Test		[9] + [*] +	Any key pressure turns the LED on	
Volume Control on Handset		[9] + [#] +	[1] = enabled	[0] = disabled

The above parameters are programmable using a password (0123) through external EEPROM. All procedures must be terminated by pressing the [PG] key. Software for factory settings is available on request.

$$Data = 4096 - (f_{osc} / (512 * 12)) * T$$

(T = Time; f_{osc} = 3.58 MHz)

The programming of timings is done by using a HEX data code as follows:

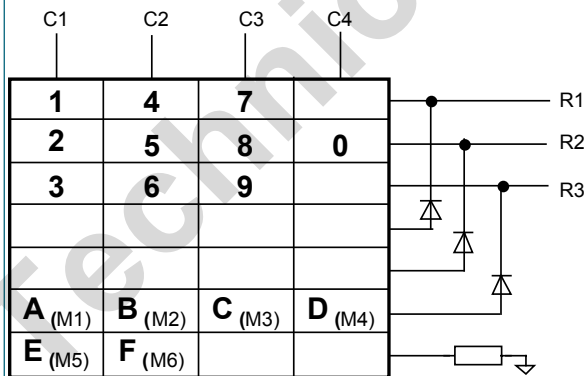

Figure 2: Keys for HEX-code entry

Table 4: Timing selection by HEX code

Parameter	Default	HEX	Binary Data
Inter-digit pause	840 ms	E17	1111 0001 0111
Tone duration	82 ms	FD0	1111 1101 0000
Inter-tone pause	82 ms	FD0	1111 1101 0000
Flash 1	101 ms	FC4	1111 1100 0100
Flash 2	285 ms	F5A	1111 0101 1010
Pause 1	1 sec	DB9	1101 1011 1001
Pause 2	3 sec	92C	1001 0010 1100
Pre-digit pause	33 ms	FED	1111 1110 1101
Post-flash pause	274	F60	1111 0110 0000

Table 5: User programming with PIN code

Function	Symbol	Procedure	Options
Call Restriction 1	CR1	[PG] + [1] + (PIN) + [*] + [1] +	Key in two digits, use [MT] for blank
Call Restriction 2	CR2	[PG] + [1] + (PIN) + [*] + [2] +	Key in two digits, use [MT] for blank
Key Lock		[PG] + [1] + (PIN) + [#] + [6] +	[0] = unlocked and [1] = locked
Clear All Memories		[PG] + [1] + (PIN) + [#] + [7] +	Press [1] to clear
Reset To Factory Settings		[PG] + [1] + (PIN) + [#] + [8] +	Press [1] to reset
Change PIN Code	PIN	[PG] + [1] + (PIN) + [0] +	Key in new PIN + new PIN
Press [PG] to store setting and terminate procedure			

Table 6: Mode programming

Function	Symbol	Procedure	Options
Select Flash	FL	[PG] + [2] +	[0] = Flash 1 and [1] = Flash 2
Select Dialing Mode ¹	DM	[PG] + [3] +	[0] = LD (pulse) and [1] = MF (DTMF)
Select Pause Time	P	[PG] + [4] +	[0] = Pause 1 and [1] = Pause 2
Easy Key Lock ²		[PG] + [5] + [3] + [9]	Toggles between locked and unlocked
Ringer Volume		[PG] + [6] +	[1] = -16 dB, [2] = -7 dB, and [3] = 0 dB (maximum)
Ringer Melody		[PG] + [7] +	[0] , [1], [2], [3], or [4]
LCD Contrast	V ₃₃	[PG] + [8] +	[1] , [2], or [3] (see also AS2591 data sheet)
Bell On/Off		[PG] + [9] +	[0] = Off and [1] = On
Press [PG] to store setting and terminate procedure			

¹ Only when DM/HM pin is set to HM

² Also selectable with jumper (see application note AN525)

Memory Allocation

The EEPROM memory consists of three areas:

A = factory settings; B = user settings; C = stored numbers

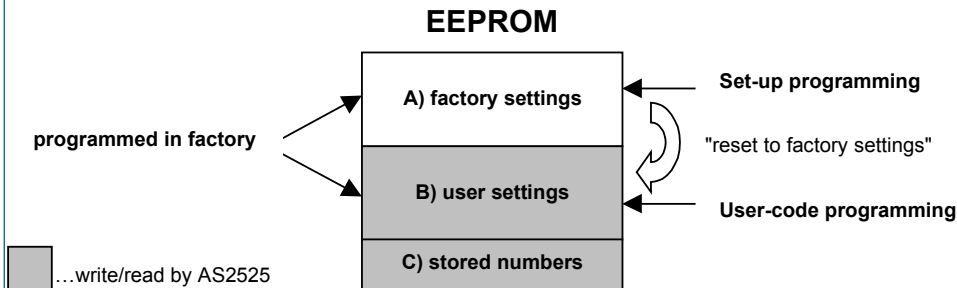

Figure 3: Memory allocation for external EEPROM

The AS2525 is writing and reading to and from area B and C during normal operation and user-code programming. Area A is protected during normal operation and contains a back-up copy of the factory settings. This back-up copy can be loaded into area B by the user with the user-code programming procedure "reset to factory settings". The only way to change the factory settings in area A is by set-up programming using password. After changing area A by set-up programming, the AS2525 automatically performs a "reset to factory settings" to load this changes also into area B.

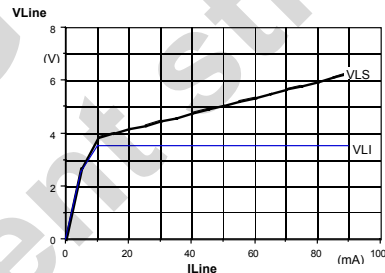

Figure 4: DC characteristic with low dc mask

Functional Description

DC Conditions

The normal operating mode is from 15 mA to 100 mA. An operating mode with reduced performance is from 5 mA to 15 mA. In the line-hold range from 0 mA to 5 mA the device is in a power down mode.

The dc characteristic is determined by the voltage at LI pin and a 30 Ω resistor between pin LI and LS. It can be calculated by the following equation:

$$V_{LS} = V_{LI} + I_{LINE} * 30 \Omega$$

VLI can be programmed to be 3.5 V or 4.5 V.

Table 7: DC mask selection

[PG] + [0] + (Password) + [#] + [3] + (digit) + [PG]	
Digit	DC Mask (dc voltage at pin LI)
[0]	Low dc mask, VLI = 3.5 Volt
[1]	High dc mask, VLI = 4.5 Volt

2/4 Wire Conversion

AS2525 has a built-in dual Wheatstone bridge with one common ground. This provides a maximum of independence of ac impedance and side-tone from each other. One can adapt side-tone without changing the ac impedance.

AC Impedance

The ac impedance of AS2525 is set to 1000 Ω. A complex impedance can be adjusted by connecting an external capacitor to the CI pin. With an external resistor of approximately 1.5 kΩ connected to the LS pin, it can be programmed to 600 Ω.

$$Z_{AC(syn)} = 33 * 30 \Omega$$

Side-Tone

A good side-tone cancellation can be achieved by using the following equation:

$$Z_{BAL}/Z_{LINE} = 10$$

This is assuming that the side-tone reference resistor, R2 (between LI and STB) is 300 Ω and R1 is 30 Ω.

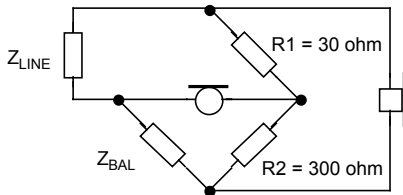

Figure 5: Side-tone balance

Transmit Path

The gain of the M1/M2 → LS path is default set to 37 dB. This gain can be changed from 30 dB to 45 dB in 1 dB steps by set-up programming.

Table 8: Handset Tx gain setting

[PG] + [0] + (Password) + [0] + [1] + (x) + [PG]			
Key (x)	Tx Gain (dB) M1/2 to LS	Key (x)	Tx Gain (dB) M1/2 to LS
[0]	30	[8]	38
[1]	31	[9]	39
[2]	32	[M1]	40
[3]	33	[M2]	41
[4]	34	[M3]	42
[5]	35	[M4]	43
[6]	36	[M5]	44
[7]	37	[M6]	45

The input is differential with an impedance of 10 kΩ. The soft clip circuit limits the output voltage swing at pin LS to 2 V_{PEAK} when activated.

Table 9: Handset Tx soft clipping selection

[PG] + [0] + (Password) + [#] + [4] + (digit) + [PG]	
Digit	Handset Tx Soft Clipping
[0]	Disabled
[1]	Enabled (2 V _{PEAK})

There is optional LLC for this path.

The gain of the M3/M4 → LS path is default set to 46 dB. This gain can be changed from 39 dB to 54 dB in 1 dB steps by set-up programming.

Table 10: Handsfree Tx gain setting

[PG] + [0] + (Password) + [0] + [3] + (x) + [PG]			
Key (x)	Tx Gain (dB) M3/4 to LS	Key (x)	Tx Gain (dB) M3/4 to LS
[0]	39	[8]	47
[1]	40	[9]	48
[2]	41	[M1]	49
[3]	42	[M2]	50
[4]	43	[M3]	51
[5]	44	[M4]	52
[6]	45	[M5]	53
[7]	46	[M6]	54

The input is differential with an impedance of 10 kΩ.

The soft clip circuit limits the output voltage swing at pin LS to 2 V_{PEAK} when activated.

Table 11: Handsfree Tx soft clipping selection

[PG] + [0] + (Password) + [9] + [2] + (digit) + [PG]	
Digit	Handsfree Tx Soft Clipping
[0]	Disabled
[1]	Enabled (2 V _{PEAK})

There is no LLC option for this path.

Receive Path

The gain of the LS → RO receive path is default set to 1 dB. This gain can be changed from -6 dB to 9 dB in 1 dB steps by set-up programming.

Table 12: Handset Rx gain setting

[PG] + [0] + (Password) + [0] + [2] + (x) + [PG]			
Key (x)	Rx Gain (dB) LS to RO	Key (x)	Rx Gain (dB) LS to RO
[0]	-6	[8]	2
[1]	-5	[9]	3
[2]	-4	[M1]	4
[3]	-3	[M2]	5
[4]	-2	[M3]	6
[5]	-1	[M4]	7
[6]	0	[M5]	8
[7]	1	[M6]	9

When the handset volume control is enabled (see Table 3: Parameter settings), the user can also change the gain within this range in 4 dB steps via the [V+]/[V-] keys. The default receive gain in handset and headset mode must lie between position 5 and 9 for correct operation of the volume control. The receive input is the differential signal of RI and STB. The soft clip circuit limits the output voltage at RO to 1 V_{PEAK}. It prevents harsh distortion and acoustic shock.

Table 13: Handset Rx soft clipping selection

[PG] + [0] + (Password) + [#] + [5] + (digit) + [PG]	
Digit	Handset Rx Soft Clipping (Earpiece)
[0]	Disabled
[1]	Enabled

There is LLC option for this path.

The gain of the LS → LO1/LO2 receive path is set to 29 dB.

This gain can be changed by set-up programming from 22 dB to -37 dB in 1 dB steps.

Table 14: Loudspeaker gain setting

[PG] + [0] + (Password) + [0] + [4] + (x) + [PG]			
Key (x)	Rx Gain (dB) LS to LO1/2	Key (x)	Rx Gain (dB) LS to LO1/2
[0]	22	[8]	30
[1]	23	[9]	31
[2]	24	[M1]	32
[3]	25	[M2]	33
[4]	26	[M3]	34
[5]	27	[M4]	35
[6]	28	[M5]	36
[7]	29	[M6]	37

The user can also change the gain using the [V+]/[V-] keys (see section "Handsfree"). The volume range is 20 dB (8 steps, each 2.5 dB).

The receive input is the differential signal of RI and STB. The soft clip circuit limits the output voltage swing at LO1/LO2 to 1 V_{PEAK}.

Table 15: Loudspeaker soft clipping selection

[PG] + [0] + (Password) + [9] + [3] + (digit) + [PG]	
Digit	Handsfree Rx Soft Clipping (Loudspeaker)
[0]	Disabled
[1]	Enabled

There is optional LLC for this path.

Line Loss Compensation (LLC)

The line loss compensation is set-up programmable and effects only the handset mode.

Table 16: Line loss compensation selection

[PG] + [0] + (Password) + [0] + [5] + (digit) + [PG]	
Digit	LLC Range
[0]	No LLC (gain independent of line current)
[1]	-1 dB/5 mA from 20 to 50 mA
[2]	-1 dB/5 mA from 45 to 75 mA

When it is activated, the transmit and receive gains for both channels are decreased by 6 dB at line currents from 20 mA to 50 mA or from 45 mA to 75 mA depending on selected range.

Handsfree

The handsfree function allows voice communication without using the handset (full 2-way speaker phone). Two voice controlled attenuators prevent acoustic coupling between the loudspeaker and the handsfree microphone.

The voice switching circuit has three states, namely idle, transmit or receive. In receive mode the attenuation of the receive path and the transmit path can be controlled by the volume keys between 0 dB and -20 dB. The following table (Table 18: Handsfree attenuation scheme) shows how voice switching is controlled.

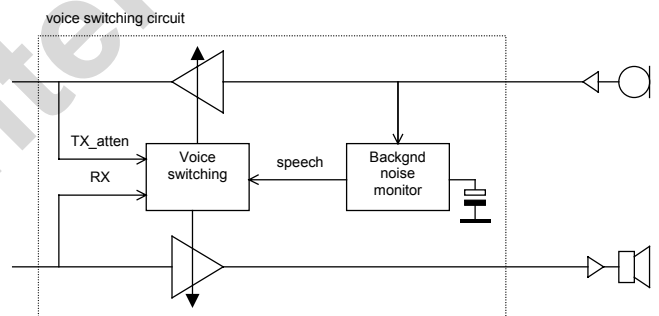

Figure 6: Handsfree voice switching

A background monitoring circuit is incorporated. This circuit can be enabled/disabled as required.

Table 17: Background noise monitoring selection

[PG] + [0] + (Password) + [#] + [6] + (digit) + [PG]	
Digit	Background Noise Monitoring
[0]	Disabled
[1]	Enabled

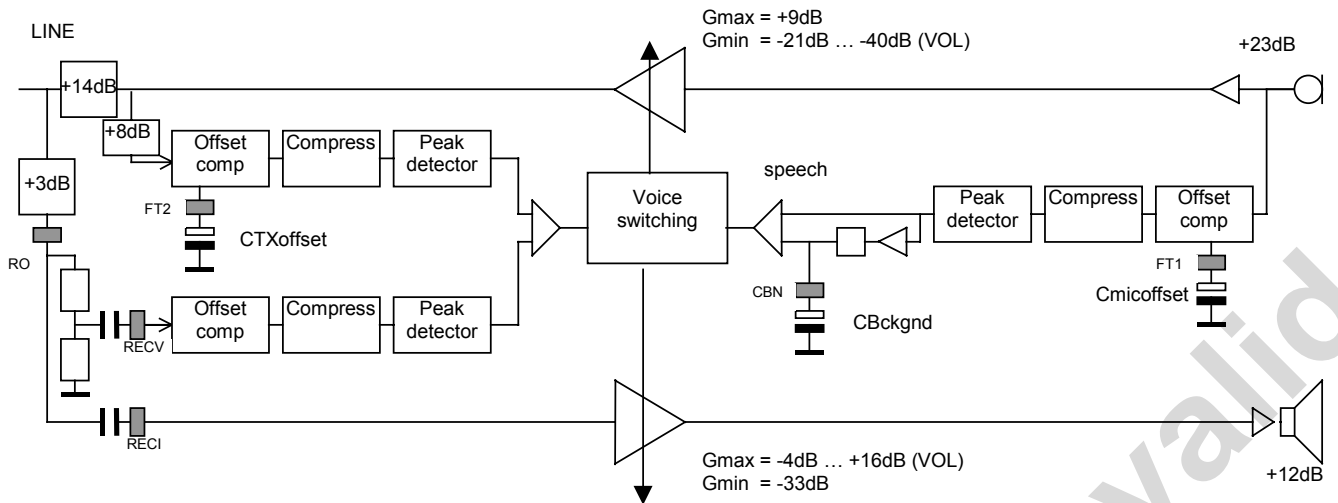

Figure 7: Signal path of handsfree circuit

Table 18: Handsfree attenuation scheme

	Speech	Mode	RX-gain	TX-gain	Remark
RX > TX_atten	X	Receive	0 dB to -20 dB	-50 dB to -30 dB	adjustable with [V+]/[V-] keys in 8 steps
TX_atten > RX	No	Idle	-25 dB	-25 dB	middle position
TX_atten > RX	Yes	Transmit	-50 dB	0 dB	independent of [V+]/[V-] keys

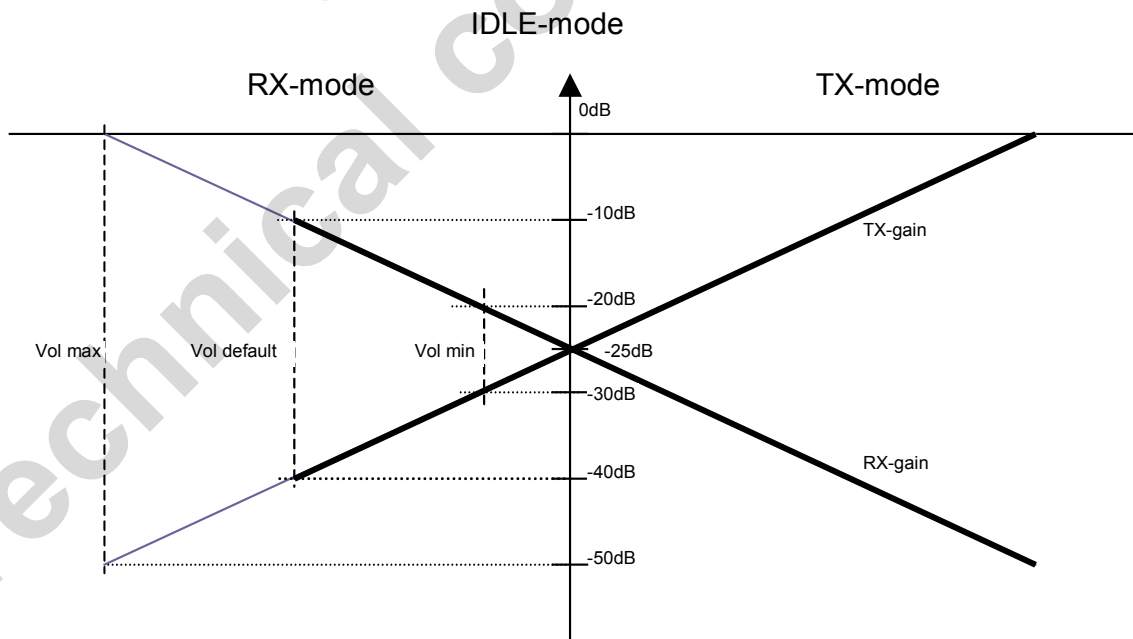

Figure 8: Gain transition of voice switching

Loudhearing

A loudhearing mode can be enabled/disabled through the set-up programming.

Table 19: Loudhearing mode selection

[PG] + [0] + (Password) + [#] + [7] + (digit) + [PG]	
Digit	Loudhearing
[0]	Enabled (LH + HF provided)
[1]	Disabled (only HF is provided)

Headset mode

Head set mode is selected by connecting pin "HEAD" to VDD and enabling the head function by service code programming (see also Table 3: Parameter settings).

Table 20: Headset Tx gain setting

[PG] + [0] + (Password) + [0] + [7] + (x) + [PG]			
Key (x)	Tx Gain (dB) M1/2 to LS	Key (x)	Tx Gain (dB) M1/2 to LS
[0]	30	[8]	38
[1]	31	[9]	39
[2]	32	[M1]	40
[3]	33	[M2]	41
[4]	34	[M3]	42
[5]	35	[M4]	43
[6]	36	[M5]	44
[7]	37	[M6]	45

Table 21: Headset Rx gain setting

[PG] + [0] + (Password) + [0] + [8] + (x) + [PG]			
Key (x)	Rx Gain (dB) LS to RO	Key (x)	Rx Gain (dB) LS to RO
[0]	-6	[8]	2
[1]	-5	[9]	3
[2]	-4	[M1]	4
[3]	-3	[M2]	5
[4]	-2	[M3]	6
[5]	-1	[M4]	7
[6]	0	[M5]	8
[7]	1	[M6]	9

If this mode is entered both hook inputs HS and HF act as electronic off-hook for handset operation. The gain in transmit and receive can be programmed by service code programming. The pin "HEAD" is only scanned once after off-hook and any change on this pin during one session will be ignored.

Ring Frequency Detection

The ring frequency detector assures that only signals with a frequency between 13 Hz and 70 Hz are regarded as valid ring signals.

When a valid ring signal is present for 100 ms continuously, the melody generator is activated and remains active as long as the ring signal is present.

Once the melody generator has been started, the ring signal is continuously monitored and the melody generator is instantly turned on or off according to the momentary presence of a valid or invalid ring signal respectively (until next POR or off-hook).

DC/DC converter

When a valid ring signal is detected, the dc/dc converter is started.

Dialing and Control Functions

Valid Keys

The key scanning is enabled in off-hook mode with V_{DD} above V_{REF} . A valid key is detected from the keyboard by connecting the appropriate row to the column ($R_{ON} < 1 \text{ k}\Omega$). This can be done using an $n \times m$ keyboard matrix with single contacts. Three diodes and a resistor are used to extend the number of rows (see Figure 1: Keyboard Layout).

PIN Code

A PIN code is available for protecting various user settings. The default PIN code is set to **1111** and can be change as follows:

1. Press **[PG]** to enter program mode
2. Press **[1] + (PIN) + [0]**
3. Key in new PIN code (valid digits: 0 - 9, #)
4. Key in new PIN code again
5. Press **[PG]** (= store and exit) or go on-hook to abort

It is also possible to reset the PIN code through set-up programming:

1. Press **[PG]** to enter program mode
2. Press **[0] + (Password) + [#] + [0]**
3. Press **[1]** to reset
4. Press **[PG]** (= store and exit) or go on-hook to abort

Call Restriction

A call restriction function is accommodated. This function can be activated using the PIN code. One or two digits can be programmed to inhibit dialing starting with said digit(s). If first digit(s) of a manual entered number or a number retrieved from a memory matches the content of the call restriction memory, dialing will be inhibited.

Storing digits for call restriction:

1. Press **[PG]** to enter program mode
2. Press **[1] + (PIN) + [*]**
3. Press **[1]** for entering first digit of call restriction or **[2]** for entering second digit
4. Key in digit for call restriction
5. Press **[PG]** (= store and exit) or go on-hook to abort.

Example 1:

Prohibit all calls with numbers starting with **0**.

Activate: **[PG] + [1] + (PIN) + [1] + [0] + [PG]**

Deactivate: **[PG] + [1] + (PIN) + [1] + [MT] + [PG]**

Example 2:

Prohibit all calls with numbers starting with **09** (numbers starting with 00..., 01..., etc. will be allowed; pauses will be ignored, i.e. numbers starting with 0 PS 9 ... will be prohibited).

Activate: **[PG] + [1] + (PIN) + [1] + [0] + [PG] + [PG] + [2] + (PIN) + [1] + [9] + [PG]**

Deactivate: **[PG] + [1] + (PIN) + [1] + [MT] + [PG] + [PG] + [2] + (PIN) + [1] + [MT] + [PG]**

Pressing the **[MT]** key in place of the digit during programming will cancel said call restriction. The first and second digit can be stored, changed or deleted independent of each other.

Key Lock

A key lock function is provided to allow the user to protect the telephone from any misuse. When this function is available through the set-up programming, it is possible to enable/disable the key lock using the user PIN code.

Enabling/disabling key lock:

1. Press **[PG]** to enter program mode
2. Press **[1] + (PIN) + [#] + [6]**
3. Press **[1]** for enable or **[0]** for disable
4. Press **[PG]** (= store and exit) or go on-hook to abort

Also an easy key lock function is provided. This function can be activated/deactivated when the key lock function is available through set-up programming and the previous mentioned key lock through PIN code is disabled.

Clear Memory Procedure

It is possible to clear all stored numbers by using the PIN code as follows:

1. Press **[PG]** to enter program mode
2. Press **[1] + (PIN) + [#] + [7]**
3. Press **[1]** for clear

4. Press **[PG]** (= store and exit) or go on-hook to abort

Reset to Factory Settings

It is possible to reset all settings to the default factory settings with following procedure:

1. Press **[PG]** to enter program mode
2. Press **[1]** + (PIN) + **[#]** + **[8]**
3. Press **[1]** for reset
4. Press **[PG]** (= store and exit) or go on-hook to abort

Dial Mode Selection

The default signaling mode (LD or MF) is selectable through following procedure:

1. Press **[PG]** to enter program mode
2. Press **[3]** to enter dial select mode
3. Press **[0]** for LD and **[1]** for MF
4. Press **[PG]** (= store and exit) or go on-hook to abort

When default LD mode is selected, a temporary change to MF can be invoked by pressing the **[*]** key. Temporary MF select with tone on first key pressure can be selected as option (see also Table 3: Parameter settings). The circuit will revert to LD by pressing the **[FL]** key or by next on-hook.

Re-Dialing (Last Number Redial)

Re-dialing is a facility that allows re-signaling of the last dialed number without keying in all the digits again. Numbers dialed out from any memory will also be stored in the LNR memory. The re-dialing works in following manner:

- Any digit (including Flash, Pause, and MF select) being dialed is storable in the LNR memory up to a total of 31 digits.
- If more than 31 digits are entered, re-dialing will be inhibited.
- Pressing the **[R/P]** key as first entry after off-hook (LNR cursor at first digit) will invoke dialing the content of the LNR memory.
- If the **[R/P]** key is pressed after entering one or more digits, the key will function as a pause key and each pressure will insert a pause.

Pauses can also be inserted by pressing the **[R/P]** key in program mode.

Flash Function

A flash, **[FL]** key, activation will invoke a timed loop break. The flash duration can be programmed through set-up (see Figure 2: Keys for HEX-code entry and Table 4: Timing selection by HEX code):

Table 22: Flash duration setting

[PG] + [0] + (Password) + [*] + (digit) + (HEX) + [PG]		
Digit	Timing	Flash Duration
[4]	HEX code	Flash 1
[5]	HEX code	Flash 2

One of two pre-programmed can be selected as follows:

1. Press **[PG]** to enter program mode
2. Press **[2]** to enter flash select mode
3. Press **[0]** for duration 1 and **[1]** for duration 2
4. Press **[PG]** (= store and exit) or go on-hook to abort

A flash entered will be stored in the LNR memory together with entered digits. After a recall a 270 ms pause will automatically be executed.

Pauses

Pauses can be inserted if the **[R/P]** key is pressed after entering one or more digits. Also during programming, pauses can be inserted by pressing the **[R/P]** key. Default pause duration is 1 second (P1) and an alternative pause of 3 second (P2) can be selected. These pauses can be changed through the set-up programming (see Table 3: Parameter settings)

Memory Keys

The keys **[M1]** to **[M8]** are direct memory access keys, **[SH]** key is used to access second level of direct memories, and the **[MR]** key is used for key-code dialing. Up to 26 numbers can be stored in the on-chip RAM. Each number can contain up to 21 digits (including pauses). During programming multiple pauses can be inserted by pressing the **[RD]** key.

Example (45678P123 is stored in M1, where P is a pause and 123 the extension number):

1. Off-hook, wait for dial tone
2. Press **[M1]**
 - 45678 is dialed out
 - Dialing halts (pauses)
 - Dialing is resumed, 123 is dialed out.

Memory dialing is cascadable up to a the maximum of 31 digits/data.

Memory Storing Procedure

Up to 28 numbers, each with maximum 24 digits, can be stored into the external EEPROM. The store procedure is as follows:

1. Press [PG] to enter program mode
2. Enter location (MR + digit³ ; M1 to 8; or SH + M1 to 8)
3. Enter number
4. Press [PG] to store and exit or go on-hook to abort
5. Go to 1 for storing further numbers

[Mute] starts and stops security storing (LCD-Symbols [and])

[R/P] inserts a pause (LCD-Symbol P)

Tone Generator

The tone generator incorporates the DTMF tones, 3 frequencies for the tone ringer and pacifier tones.

DTMF

The DTMF generator provides 7 frequencies.

Table 23: DTMF frequencies

Digit	Frequency
Rows	Low Group
1 - 2 - 3	697 Hz
4 - 5 - 6	770 Hz
7 - 8 - 9	852 Hz
* - 0 - #	941 Hz
Columns	High Group
1 - 4 - 7 - *	1209 Hz
2 - 5 - 8 - 0	1336 Hz
3 - 6 - 9 - #	1477 Hz

The MF output level can be set through set-up programming. The range is from -18 dBm to -6 dBm in 1 dB steps.

Table 24: DTMF level settings

[PG] + [0] + (Password) + [0] + [6] + (x) + [PG]			
Key (x)	Level (dBm) Low Group	Key (x)	Level (dBm) Low Group
[0]	-18	[7]	-11
[1]	-17	[8]	-10
[2]	-16	[9]	-9
[3]	-15	[M1]	-8
[4]	-14	[M2]	-7
[5]	-13	[M3]	-6
[6]	-12		

³ Digit includes 0 – 9, * and #

The pre-emphasis is 2.6 dB. The DTMF tones are according to CEPT recommendations.

Tone Ringer (Melody/Volume)

The tone ringer incorporates two basic selection, namely 2-tone or 3-tone melodies. The default set-up selection is the 3-tone ringer.

Table 25: Basic ringer melody selection

[PG] + [0] + (Password) + [#] + [8] + (digit) + [PG]	
Digit	Ringer Melody
[0]	2-tone
[1]	3-tone

The user can chose the following melodies as shown in below table.

Table 26: 3-tone melody programming

Procedure	Digit	Sequence	Rate
[PG] + [7] +	[0]	F1 F2 F3 F1 F2 F3	1
	[1]	F1 F2 F3 F1 F2 F3	2
	[2]	F1 F2 F3 F1 F2 F3	4
	[3]	F1 F2 F3 F1 F2 F3	6
	[4]	F1 F2 F3 F1 F2 F3	10
Press [PG] to store and terminate			

The chosen melody will be heard in the loudspeaker during programming. Pressing the [PG] key will end the procedure and the last selected melody will be stored.

When 2-tone melody is selected through the set-up procedure, it is possible to chose the following melodies:

Table 27: 2-tone melody programming

Procedure	Digit	Sequence	Rate
[PG] + [7] +	[0]	F1 F2 F1 F2 F1 F2	2
	[1]	F1 F2 F1 F2 F1 F2	5
	[2]	F1 F3 F1 F3 F1 F3	2
	[3]	F1 F3 F1 F3 F1 F3	5
	[4]	F2 F3 F2 F3 F2 F3	2
Press [PG] to store and terminate			

Repetition rate means that a sequence of 6 frequencies is repeated 1, 2, 4, 5, 6 or 10 times within 1 second.

Pacifier Tone

Any key entry is acknowledged by a pacifier tone (key-in tone) of 1333 Hz. The pacifier tone can be enabled/disabled through set-up programming.

Table 28: Pacifier tone selection

[PG] + [0] + (Password) + [#] + [9] + (digit) + [PG]	
Digit	Pacifier Tone (Key-in Tone)
[0]	Disabled
[1]	Enabled

Table 29: Pacifier tones

Key Entry	Frequency	Duration
Acknowledge	1333 Hz	40 ms
Reject/Terminate	1333 Hz	4 x 40 ms

An invalid key entry will be indicated by a rejection tone of 4 times 40 ms.

By MF dialing the DTMF tones are provided to the earpiece as comfort tone. The level of the comfort is selected through the set-up programming.

Table 30: DTMF comfort tone level setting

[PG] + [0] + (Password) + [0] + (y + x) + [PG]			
Key (y + x)	Level (dBr) Earpiece	Key (y + x)	Level (dBr) Loudspeaker
[9] + [0]	-36	[0] + [0]	-15
[9] + [1]	-30	[0] + [1]	-9
[9] + [2]	-24	[0] + [2]	-3
[9] + [3]	-18	[0] + [3]	3

Serial Bus

The AS2525 incorporates a microwire™ compatible serial bus (DO, DI, and CLK) with two chip select outputs (CS1 and CS2). The serial bus is used to:

- sending data to the LCD driver (AS2591) when a key is pressed or a number is dialed out
- reading and writing to the external EEPROM under following conditions:

Table 31: EEPROM read/write timings

ACTION	DURATION
After off-hook (debounced)	50 ms
After on-hook (debounced)	200 ms
After first rising edge at FCI	10 ms
After PG is terminated	12...600 ms
After pressing [V+]/[V-]	20 ms

See also AS2591 data sheet for further information.

LCD Control

The AS2525 is designed to work together with the LCD driver AS2591 (see also AS2591 data sheet).

Electrical Characteristics

Absolute maximum ratings

Positive Supply Voltage	$-0.3 \leq V_{DD} \leq 7V$
Input Current	+/- 25 mA
Input Voltage (LS)	$-0.3V \leq V_{IN} \leq 12V$
Input Voltage (LI, CS)	$-0.3V \leq V_{IN} \leq 8V$
Input Voltage (STB, RI)	$-2V \leq V_{IN} \leq V_{DD} + 0.3V$
Digital Input Voltage	$-0.3V \leq V_{IN} \leq V_{DD} + 0.3V$
Electrostatic Discharge	+/- 1000V
Storage Temperature Range	-65 to +125°C
Total Power Dissipation	500mW

* Exceeding these figures may cause permanent damage. Functional operation under these conditions is not permitted.

Recommended Operating Range

Symbol	Parameter	Conditions	Min.	Typ.*	Max.	Units
V _{DD}	Supply Voltage (internally generated)	Speech mode	3.0		5.0	V
T _{AMB}	Ambient Operating Temp. Range		-25		+70	°C
f _{OSC}	Oscillator Frequency	Resonator: Murata CSA 3.58M G312AM		3.58		MHz

* Typical figures are at 25°C and are for design aid only; not guaranteed and not subject to production testing.

DC Characteristics

(I_{LINE} = 15 mA, recommended operating conditions unless otherwise specified)

Symbol	Parameter	Conditions	Min.	Typ.	Max.	Units
I _{DD}	Operating Supply Current	Speech mode		4	6	mA
		Handsfree mode		11	13	mA
		LD dialing, V _{DD} = 2.5V		200		µA
		Ring mode, V _{DD} = 2.5V		300		µA
I _{DD-EXT}	Available Supply Current for Peripheral Circuits	Speech mode or MF dialing	2			mA
I _{DD0}	Idle Current	Idle mode, V _{DD} = 2 V, T _{AMB} = 25°C		2		µA
V _{LI}	Line Voltage, LIVolt = 0 Line Voltage, LIVolt = 1	13 mA < I _{LINE} < 100 mA	3.2	3.5	3.8	V
			4.2	4.5	4.8	V
I _{OL}	Output Current, Sink Pin CS, SS	V _{OL} = 0.4V		1		mA
V _{IL}	Input Low Voltage	T _{AMB} = 25°C	V _{SS}		0.3 V _{DD}	V
V _{IH}	Input High Voltage	T _{AMB} = 25°C	0.7 V _{DD}		V _{DD}	V

AC Electrical Characteristics

I_{LINE} = 15 mA; f = 800 Hz; Z_{AC} = 1000Ω; recommended operating conditions and default settings unless otherwise specified.

Transmit

Symbol	Parameter	Conditions	Min.	Typ.	Max.	Units
A _{TX}	Transmit Gain, default	M1/M2 to LS	34.3	35.8	37.3	dB
		M3/M4 to LS	42.0	44.0	46.0	dB
	Variation with Frequency	f = 500 Hz to 3.4 kHz		+/- 0.8		dB
THD	Distortion	V _{LS} < 0.25 V _{RMS}			2	%
V _{AGC}	Soft Clip Level	V _{LS} =		2		V
A _{SCO}	Soft Clip Overdrive			20		dB
t _{DECAY}	Attack Time			70		μs/6dB
t _{DECAY}	Decay Time			100		ms/6dB
Z _{IN}	Input Impedance; M1/M2			10		kΩ
	Input Impedance; M3/M4			10		kΩ
A _{MUTE}	Mute Attenuation	Mute activated	60			dB
V _{NO}	Noise Output Voltage	T _{AMB} = 25°C, handset mode A _{TX} = 37 dB			-72	dBmp
V _{IN MAX}	Input Voltage Range; M1/M2 and M3/M4	Differential		+/- 1		V _{PEAK}

Line Driver

Symbol	Parameter	Test Conditions	Min.	Typ.	Max.	Units
V _{IN MAX}	Input Voltage Range; LI			+/- 2		V _{PEAK}
V _{TX}	Dynamic Range; LI			+/- 2		V _{PEAK}
RL	Return Loss	Z _{RL} = 1000 Ω; T _{AMB} = 25°C	18			dB
ΔZ _{AC/TEMP}	Temperature Variation			0.5		Ω/°C

Receive

Symbol	Parameter	Conditions	Min.	Typ.	Max.	Units
A _{RX}	Receive Gain, Default	LS to RO; volume reset	-2.0	-0.5	1.0	dB
		LS to LO1/LO2; volume max.	25.0	27.0	29.0	dB
A _{RX-VOL}	Volume Control Range	8 steps through [V-]/[V+] keys		15		dB
ΔA _{RX}	Variation with Frequency	f = 500 Hz to 3.4 kHz		+/- 0.8		dB
THD	Distortion, RO	V _{RO} = 0.25 V _{RMS}			2	%
		Distortion, LO1/LO2	V _{LO1/2} = 0.25 V _{RMS}		5	%
V _{AGC}	Soft Clip Level	V _{RO} =		1		V _{PEAK}
A _{SCO}	Soft Clip Overdrive			10		dB
t _{DECAY}	Attack Time	V _{RI} > 0.8 V _{RMS}		70		μs/6dB
t _{DECAY}	Decay Time			100		ms/6dB
V _{NO}	Noise Output Voltage, RO	T _{AMB} = 25°C, A _{RX} = 3 dB			-72	dBmp
V _{UFC}	Unwanted Frequency Components	50 Hz.....20 kHz			-60	dBmp
Z _{IN}	Input Impedance, RI			8		kΩ
V _{IN-MAX RI}	Input Voltage Range, RI			+/- 2		V _{PEAK}
A _{ST}	Side Tone Cancellation	V _{RI} < 0.25 V _{RMS}	26			dB
Z _{IN}	Input Impedance, STB			80		kΩ
V _{IN-MAX ST}	Input Voltage Range, STB			+/- 2		V _{PEAK}

General Timings

Symbol	Parameter	Conditions	Min.	Typ.	Max.	Units
t _d	Key Debounce Time			15		ms
t _{HS-L}	Low/High Debounce	HS Input (going off-hook)		15		ms
t _{HS-H}	High/Low Debounce	HS Input (going on-hook)		210		ms
t _{FD}	Flash Duration	FL 1 (default)	100		102	ms
		FL 2 (default)	275	285	300	ms
t _{PFP}	Post Flash Pause			274		ms
t _{AP}	Access Pause	P1 (default)	0.9	1.0	1.1	sec.
		P2 (default)		3.0		sec.

DTMF

Symbol	Parameter	Conditions	Min.	Typ.	Max.	Units
DF	Frequency Deviation	Deviation of ceramic resonator is not included			1.2	%
V _{MF}	MF Tone Level at LS (Low Group)	Default	-4.5	-5.5	-6.5	dBm
V _{MF-RANGE}	MF Tone Level Range at LS (Low Group)	13 steps		-18/-6		dBm
ΔV _{L,H}	Pre-emphasis, Low to High		2.0	2.6	3.2	dBr
V _{UFC}	Unwanted Frequency Components	300 Hz...4.3 kHz 4.3 kHz...7 kHz 7 kHz...10 kHz 10 kHz...14 kHz 14 kHz...28.5 kHz 28.5 kHz...40 kHz			-40 -46 -52 -58 -70 -80	dBm dBm dBm dBm dBm dBm
t _{TD}	Tone Duration, Minimum	Default	80	82.3	85	ms
t _{ITP}	Inter Tone Pause, Min.	Default	80	82.3	85	ms
t _{TR}	Tone Rise Time	From 10% to 90% amplitude			5	ms
t _{TR}	Tone Fall Time	From 90% to 10% amplitude			5	ms
V _{CT}	Comfort Tone Level, RO	Relative to LS, 4 steps		-36 -18		dBr

LD Dialing

Symbol	Parameter	Conditions	Min.	Typ.	Max.	Units
t _{DR}	Dialing Rate	Default Option	9.53	10 20	10.5	pps pps
t _B	Break Period	Default Option Option	57	61.2 66 33	63	ms ms ms
t _M	Make Period	Default Option Option	38	40.8 33 16.5	42	ms ms ms
t _{PDP}	Pre-Digit Pause			35		ms
t _{IDP}	Inter-Digit Pause		800		880	ms

Tone Ringer

Symbol	Parameter	Conditions	Min.	Typ.	Max.	Units
F1	Frequency 1		770	800	830	Hz
F2	Frequency 2		1025	1067	1110	Hz
F3	Frequency 3		1280	1333	1385	Hz
t _{DT}	Detection Time	Initial		100		ms
f _{MIN}	Min. Detection Frequency		12	13	14	Hz
f _{MAX}	Max. Detection Frequency		68	70	75	Hz

Pacifier Tone

Symbol	Parameter	Conditions	Min.	Typ.	Max.	Units
V _{PARO}	Tone Output Level, RO	RL = 150 Ω		30		mV _{P-P}
	Tone Output Level, LO1/2	RL = 32 Ω		300		mV _{P-P}
f _{PT}	Frequency	Key entry		1333		Hz
t _{TBD}	Tone Burst Duration	Key entry		40		ms
		Acknowledge, terminate PG mode		140		ms
		Rejection, invalid key entry		4x40		ms
t _{TTP}	Inter-Tone Pause			80		ms

Timing Diagrams

LD dialling

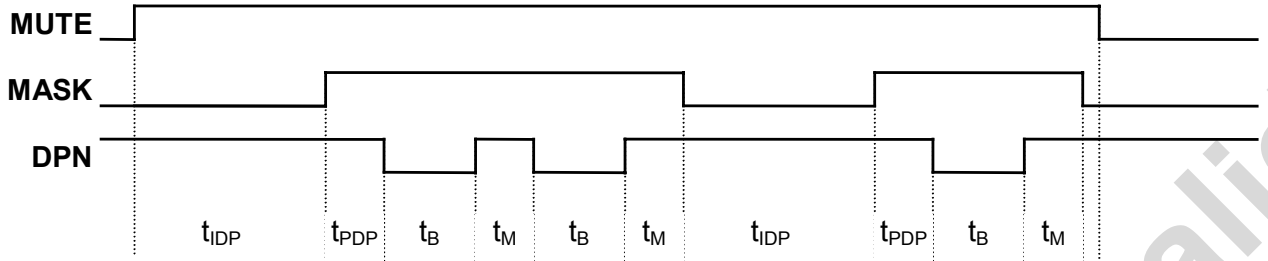

LD dialling with access pause

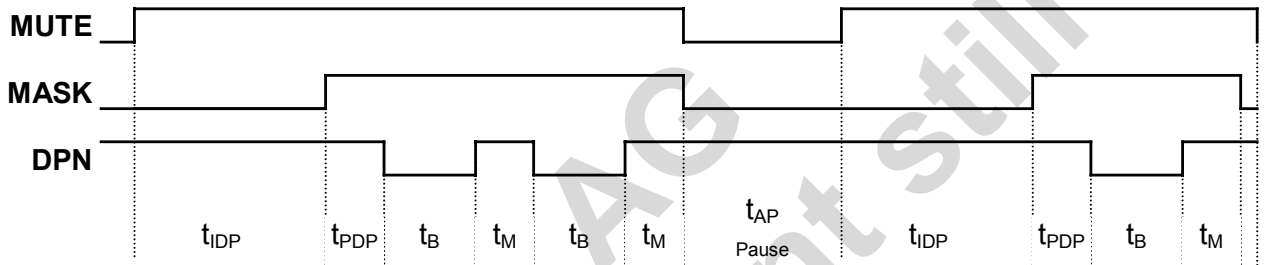

MF dialling

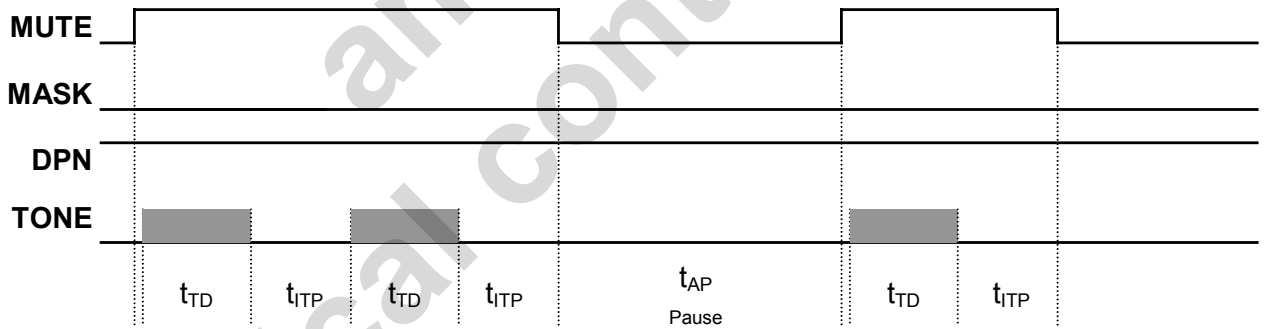

Figure 9: Timing diagrams

Test Circuit

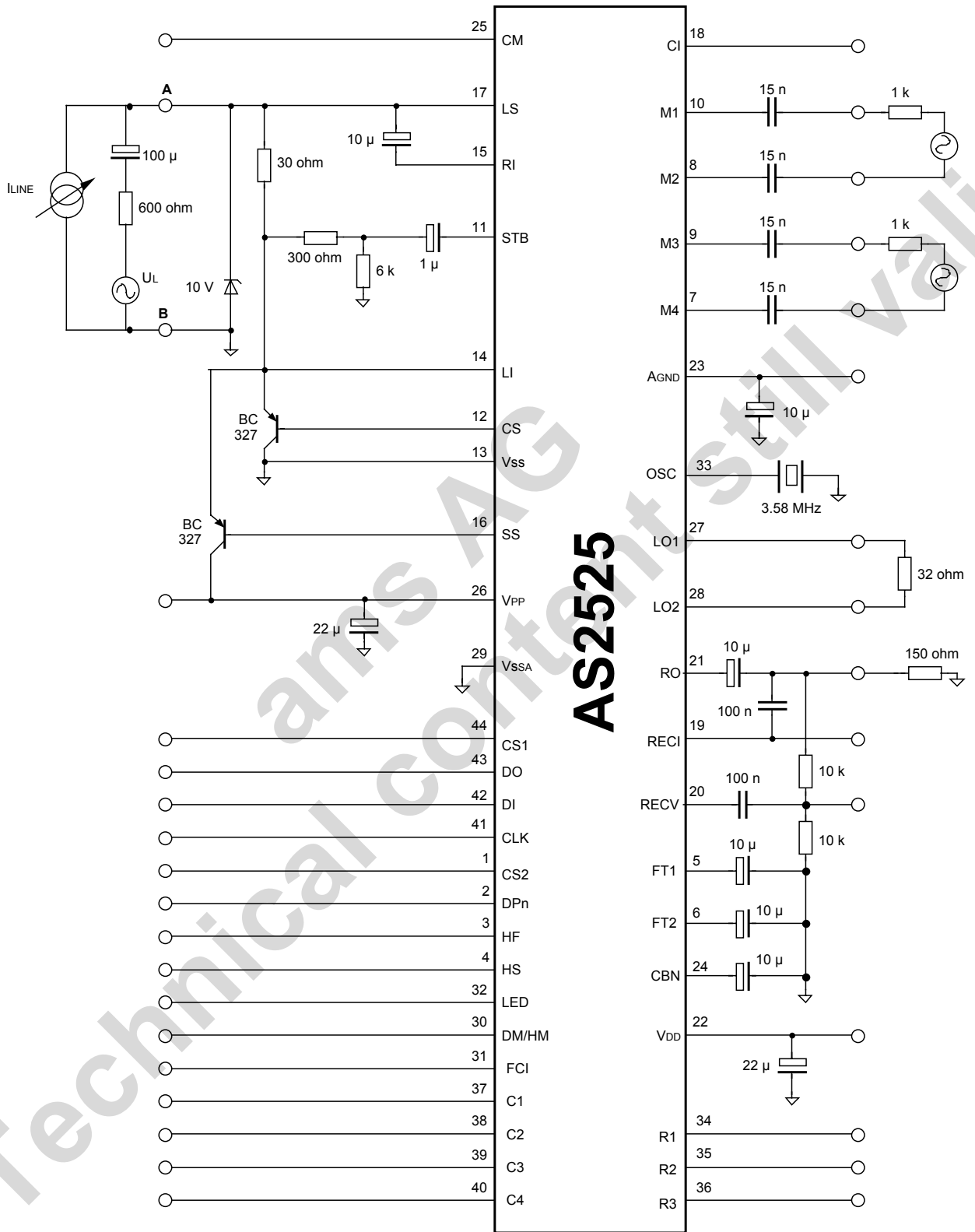

Figure 10: Test circuit

Typical Application

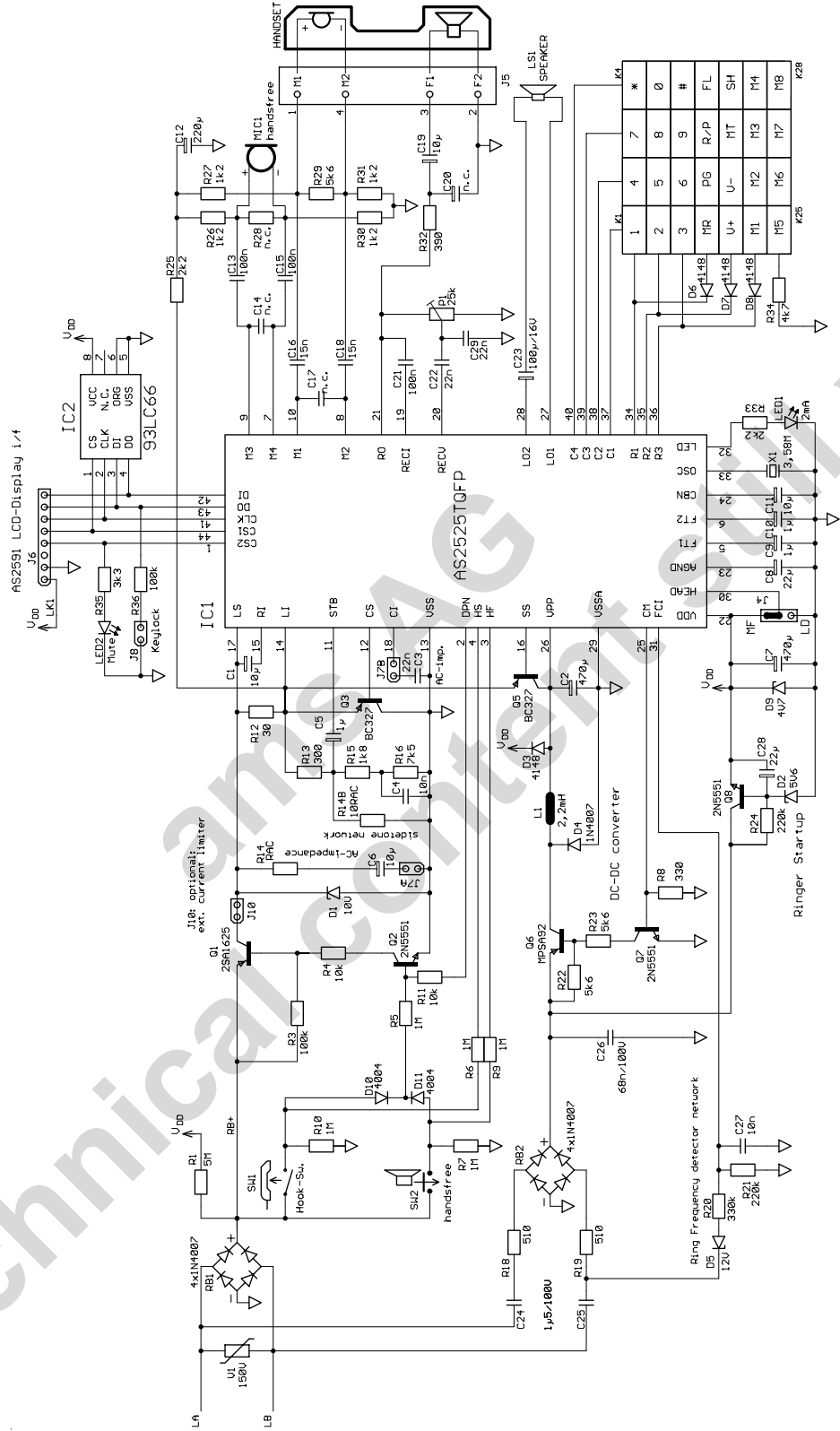
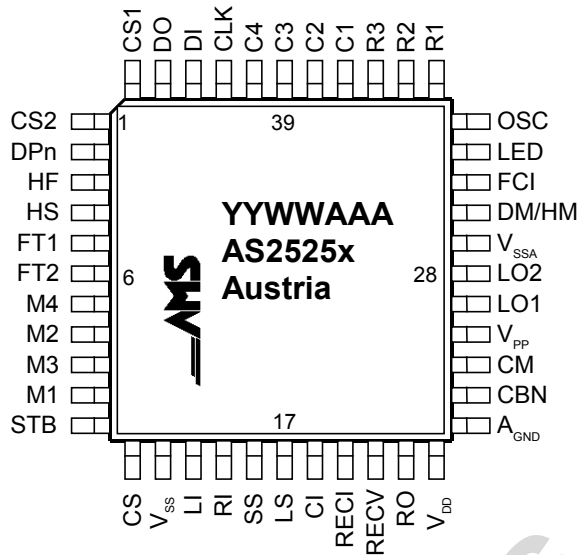

Figure 11: Typical application

Packaging

44-in plastic TQFP (suffix Q)
 For exact mechanical package dimensions please see austriamicrosystemsAG packaging information.

Marking, Pin-out



- YY year of production
- WW calendar week of production
- AAA austriamicrosystemsAG assembly ID
- X revision

Ordering Information

Number	Package	Description
AS2525 Q	TQFP	plastic thin quad flat package – 44 leads (suffix T)
AS2525 F	DOF	Dice-on-Foil

Devices sold by austriamicrosystems AG are covered by the warranty and patent identification provisions appearing in its Term of Sale. austriamicrosystems AG makes no warranty, express, statutory, implied, or by description regarding the information set forth herein or regarding the freedom of the described devices from patent infringement. austriamicrosystems AG reserves the right to change specifications and prices at any time and without notice. Therefore, prior to designing this product into a system, it is necessary to check with austriamicrosystems AG for current information. This product is intended for use in normal commercial applications. Applications requiring extended temperature range, unusual environmental requirements, or high reliability applications, such as military, medical life-support or life-sustaining equipment are specifically not recommended without additional processing by austriamicrosystems AG for each application.

Copyright

Copyright © 1997-2002, austriamicrosystems AG, Schloss Premstaetten, 8141 Unterpremstaetten, Austria-Europe. Trademarks Registered ©. All rights reserved. The material herein may not be reproduced, adapted, merged, translated, stored, or used without the prior written consent of the copyright owner.

The information furnished here by austriamicrosystems AG is believed to be correct and accurate. However, austriamicrosystems AG shall not be liable to recipient or any third party for any damages, including but not limited to personal injury, property damage, loss of profits, loss of use, interruption of business or indirect, special, incidental or consequential damages, of any kind, in connection with or arising out of the furnishing, performance or use of the technical data herein. No obligation or liability to recipient or any third party shall arise or flow out of austriamicrosystems AG rendering of technical or other services.

Contact

Headquarters

austriamicrosystems AG
Communications Business Unit
A 8141 Schloss Premstätten, Austria
T. +43 (0) 3136 500 0
F. +43 (0) 3136 525 01
www.austriamicrosystems.com

Sales Offices

Germany

austriamicrosystems Germany GmbH
Tegernseer Landstrasse 85
D-81539 München, Germany
Phone: +49/89/693643-0
Fax: +49/89/693643-66

France

austriamicrosystems France S.a.r.l.
124, Avenue de Paris
F-94300 Vincennes, France
Phone: +33/1/43 74 00 90
Fax: +33/1/43 74 20 98

Italy

austriamicrosystems Italy S.r.l.
Via Leone Tolstoj, 64
I-20146 Milano, Italy
Phone: +39/0242/36713
Fax: +39/0242/290889

Switzerland

austriamicrosystems Switzerland AG
Rietstrasse 4
CH-8640 Rapperswil, Switzerland
Phone: +41/55/220 9000
Fax: +41/55/220 9001

USA (west)

austriamicrosystems USA, Inc.
Suite 116, 4030 Moorpark Ave,
San Jose, CA 95117, USA
Phone: +1/408/345 1790
Fax: +1/408/345 1795

USA (east)

austriamicrosystems USA, Inc.
Suite 400, 8601 Six Forks Road
Raleigh, NC 27615, USA
Phone: +1/919/676 5292
Fax: +1/919/676 5305

United Kingdom

austriamicrosystems UK, Ltd.
Coliseum Business Centre, Watchmoor Park
Camberley, Surrey, GU15 3YL, UK
Phone: +44/1276/23 3 99
Fax: +44/1276/29 3 53

Japan

austriamicrosystems AG
Shin Yokohama Daini, Center Bldg. 10F
3-19-5, Shin Yokohama
Kohoku-ku, Yokohama 222-0033, Japan
Phone: +81/45/474 0962
Fax: +81/45/472 9845

Distributors & Representatives

austriamicrosystems AG is represented by distributors in the following countries. Please contact your nearest regional sales office for the distributor address:

Spain, Israel, Korea, Hong-Kong, Taiwan, Malaysia, Singapore, India, Brazil

Application Support

Please contact your local sales office or your distributor.

Mouser Electronics

Authorized Distributor

Click to View Pricing, Inventory, Delivery & Lifecycle Information:

[ams:](#)

[AS2525-DB](#) [AS2525 DB](#)



Стандарт Электрон Связь

Мы молодая и активно развивающаяся компания в области поставок электронных компонентов. Мы поставляем электронные компоненты отечественного и импортного производства напрямую от производителей и с крупнейших складов мира.

Благодаря сотрудничеству с мировыми поставщиками мы осуществляем комплексные и плановые поставки широчайшего спектра электронных компонентов.

Собственная эффективная логистика и склад в обеспечивает надежную поставку продукции в точно указанные сроки по всей России.

Мы осуществляем техническую поддержку нашим клиентам и предпродажную проверку качества продукции. На все поставляемые продукты мы предоставляем гарантию .

Осуществляем поставки продукции под контролем ВП МО РФ на предприятия военно-промышленного комплекса России , а также работаем в рамках 275 ФЗ с открытием отдельных счетов в уполномоченном банке. Система менеджмента качества компании соответствует требованиям ГОСТ ISO 9001.

Минимальные сроки поставки, гибкие цены, неограниченный ассортимент и индивидуальный подход к клиентам являются основой для выстраивания долгосрочного и эффективного сотрудничества с предприятиями радиоэлектронной промышленности, предприятиями ВПК и научно-исследовательскими институтами России.

С нами вы становитесь еще успешнее!

Наши контакты:

Телефон: +7 812 627 14 35

Электронная почта: sales@st-electron.ru

Адрес: 198099, Санкт-Петербург,
Промышленная ул, дом № 19, литера Н,
помещение 100-Н Офис 331