

### Devices Connected/Referenced

<a href="#">ADF4106</a>	PLL Frequency Synthesizer
<a href="#">ADCLK905</a>	ECL 1:1 Clock Buffer
<a href="#">ADCLK925</a>	ECL 1:2 Clock Buffer
<a href="#">ADP150</a>	3.3 V Low noise Linear Regulator
<a href="#">ADP7102</a>	5 V Low noise Linear Regulator

## Extending the Low Frequency Range of a High Performance Phase Locked Loop

### EVALUATION AND DESIGN SUPPORT

#### Circuit Evaluation Boards

[CN-0290 Circuit Evaluation Board \(EVAL-CN0290-SDPZ\)](#)

[System Demonstration Platform \(EVAL-SDP-CS1Z\)](#)

#### Design and Integration Files

[Schematics, Layout Files, Bill of Materials](#)

### CIRCUIT FUNCTION AND BENEFITS

The circuit shown in Figure 1 is a high performance phase locked loop (PLL) that uses high speed clock buffers and low noise LDOs to maintain low phase noise even at low reference and RF frequencies.

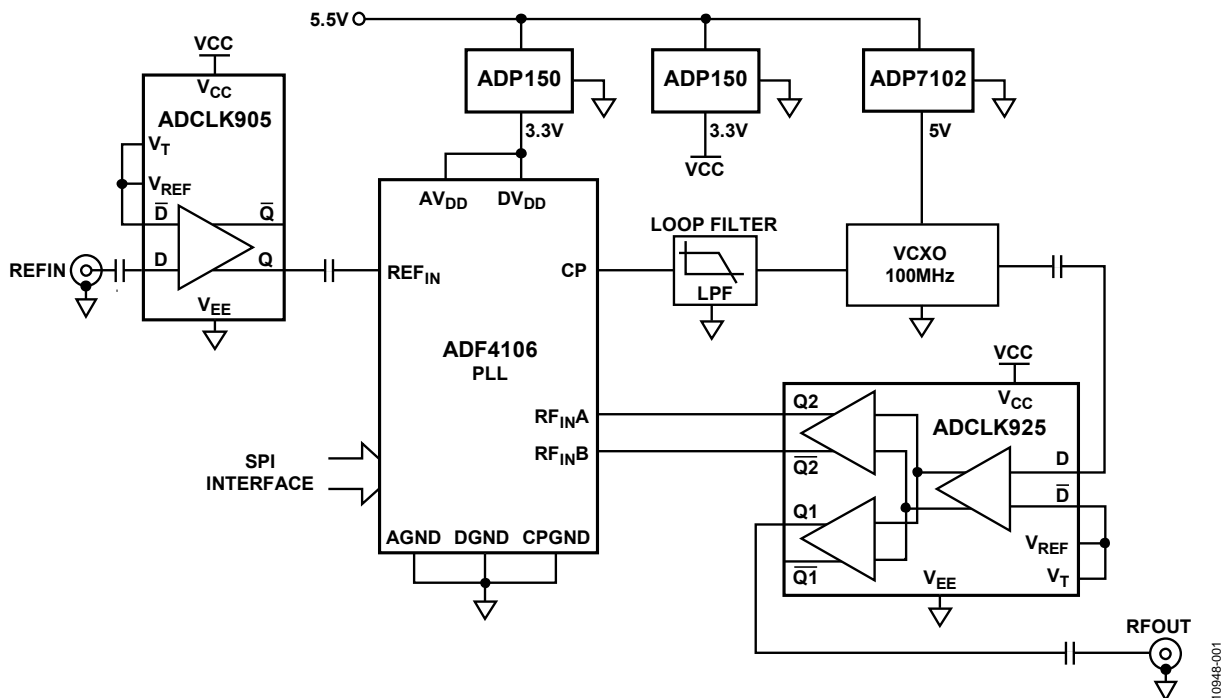

Figure 1. Block Diagram of the EVAL-CN0290-SDPZ. Simplified Schematic: All Connections and Decoupling not Shown

#### Rev. 0

Circuits from the Lab™ circuits from Analog Devices have been designed and built by Analog Devices engineers. Standard engineering practices have been employed in the design and construction of each circuit, and their function and performance have been tested and verified in a lab environment at room temperature. However, you are solely responsible for testing the circuit and determining its suitability and applicability for your use and application. Accordingly, in no event shall Analog Devices be liable for direct, indirect, special, incidental, consequential or punitive damages due to any cause whatsoever connected to the use of any Circuits from the Lab circuits. (Continued on last page)

For example, the minimum reference frequency and the RF input frequency of a number of Analog Devices PLLs, such as the [ADF4106](#), are specified for 20 MHz and 500 MHz, respectively. The frequency range can be lowered to a 10 MHz reference frequency and a 100 MHz RF input using the additional clock buffers as in Figure 1.

**CIRCUIT DESCRIPTION**

The [ADF4106](#) frequency synthesizer can be used to implement the local oscillator function in the up-conversion and down-conversion sections of RF receivers, transmitters, signal analyzers, data generators, or any RF application that requires a

local oscillator function. A complete phase-locked loop (PLL) is realized when the synthesizer is used with an external loop filter and voltage controlled oscillator (VCO).

The [ADF4106](#) is an integer-N PLL where the channel step size is an integer number N. This device has an RF frequency output range up to 6 GHz, is easy to use, and is specified for low phase noise, typically  $-223$  dBc/Hz (normalized phase noise floor). Figure.1 shows the block diagram, and Figure 2 shows the simplified schematic of a complete phase locked loop using the [ADF4106](#) in a low noise single frequency clock application.

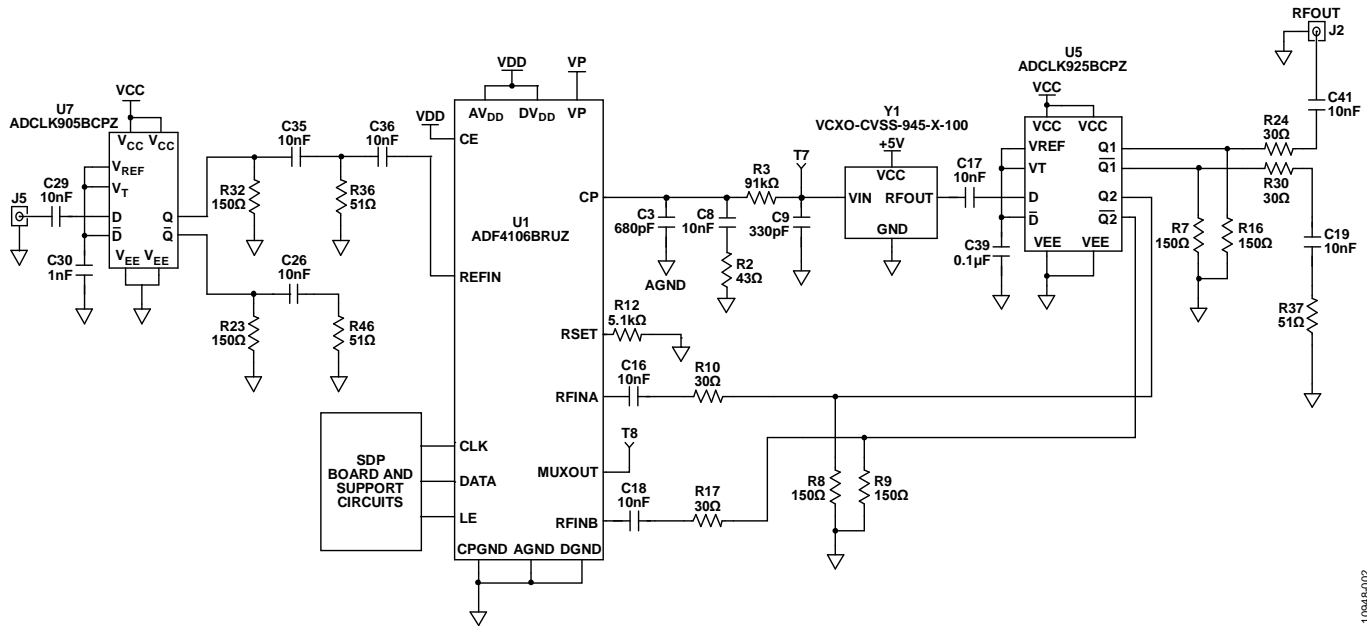

Figure 2. Simplified Schematic of Low Phase Noise Phase Locked Loop with Clock Buffers for Reference Frequency and RF Frequency Inputs of [ADF4106](#)

1 0948-002

A low noise 10 MHz reference source is buffered by the [ADCLK905](#) and ac coupled to the  $REF_{IN}$  of the [ADF4106](#) PLL. The VCO is a low noise, 100 MHz sinewave VCXO, whose output is ac coupled to the 50  $\Omega$  input load of the [ADCLK925](#). Interfacing between the VCXO and the [ADCLK925](#) is very simple, as both devices are matched in terms of their load and signal level requirements. The [ADCLK925](#) 1:2 buffer output stage provides both the  $RFOUT$  signal and the required RF feedback signal to the PLL.

The [ADF4106](#) PLL is powered from a dedicated 3.3 V [ADP150](#) low noise LDO, and the two clock buffers ([ADCLK905](#), [ADCLK925](#)) are powered using a second [ADP150](#). The [ADP150](#) has an output voltage noise of only 9  $\mu V$  rms, which ensures low phase noise for both the PLL and the clock buffers.

The low noise VCXO is powered from the [ADP7102](#) low noise 5 V linear regulator to reduce the impact of VCO pushing (equivalent to power supply rejection).

### Reference Input Clock Buffer

The clock buffers for the  $REF_{IN}$  and the  $RF_{IN}$  input stages of the PLL need to have low additive jitter, sufficient slew rate at the frequency of operation, and adequate signal swing to match the [ADF4106](#) requirements.

The [ADCLK905/ADCLK925](#) are ultrafast ECL clock/data buffers, designed specifically to minimize added random jitter over a wide input slew rate. They feature full-swing ECL emitter coupled logic output drivers, 95 ps propagation delay and 60 fs random jitter. The rise/fall time (20% to 80%) of these parts is 60 ps typical which corresponds to a slew rate of approximately 8000 V/ $\mu s$ .

The [ADCLK905](#) is used to buffer the 10 MHz  $REF_{IN}$  frequency source. A reference frequency of 10 MHz is common in many applications. Depending on the signal swing available, the slew rate may not meet the minimum 50 V/ $\mu s$  slew rate requirement of the [ADF4106](#). For example, the slew rate of a 10 MHz 0 dBm sine wave is only 20 V/ $\mu s$ .

The [ADCLK905](#) was chosen as the  $REF_{IN}$  clock buffer in order to increase the slew rate of the 10 MHz source. The [ADCLK905](#) low additive jitter ensures that any additive jitter introduced by the  $REF_{IN}$  clock buffer is minimal. Reference noise within the bandwidth of the PLL is not attenuated, therefore keeping the reference noise low, is a key factor in component choice. The low 60 fs additive jitter of the [ADCLK905](#) ensures that this is the case. In a 50  $\Omega$  environment, input and output matching have a significant impact on performance. The input buffer of the [ADCLK905](#) provides internal 50  $\Omega$  termination resistors for both D inputs. The center tap,  $V_T$ , between these 50  $\Omega$  resistors is connected externally to the complementary D input and to the  $V_{REF}$  pin. These pins are decoupled with a ceramic capacitor.

The PECL output stage of the [ADCLK905](#) directly drives 800 mV each side into 50  $\Omega$  terminated to  $V_{CC} - 2 V$ . The termination is implemented with a single resistor termination to

each [ADCLK905](#) output. For  $V_{CC} = 3.3 V$ , 150  $\Omega$  connected to ground is the recommended value.

The outputs are designed to drive transmission lines, and each output pin should see matched load impedances. The [ADCLK905](#) Q output is ac coupled to a 50  $\Omega$  load, before ac coupling to the high impedance input of the [ADF4106](#)  $REF_{IN}$ . The unused complementary Q output should be terminated with a similar load.

### RF Input Clock Buffer

The [ADCLK925](#) is used to buffer the 100 MHz  $RF_{IN}$  from the low noise VCXO. The  $RF_{IN}$  has a required minimum slew rate of 320 V/ $\mu s$ . The [ADCLK925](#) provides the required slew rate at the  $RF_{IN}$  input. The low additive jitter of the [ADCLK925](#) has minimal impact on the PLL phase noise performance. The 1:2 output stage of the [ADCLK925](#) simplifies feedback to the PLL without the need for a splitter and matching components.

The PECL output stages directly drives 800 mV each side into 50  $\Omega$  terminated to  $V_{CC} - 2 V$ . This is achieved without the need for an additional supply by using a single 150  $\Omega$  resistor to ground, as shown in Figure 2. The  $RF_{IN}$  input stage of the [ADF4106](#) is specified for a maximum signal level of  $\pm 600$  mV. A series resistor of 30  $\Omega$  reduces the [ADCLK925](#) output swing to below this value. The [ADCLK925](#) output is ac coupled to the differential 50  $\Omega$  input of the [ADF4106](#). The second [ADCLK925](#) output is terminated in a similar manner and provides the  $RFOUT$  signal.

### PLL Design and Performance

The [ADIsimPLL](#)™ software was used to design the loop filter of the PLL using the required low frequency values of 10 MHz  $REF_{IN}$  and 100 MHz  $RF_{IN}$ . The loop filter has 818 Hz bandwidth and 45° phase margin.

Figure 3 shows the [ADIsimPLL](#) simulated phase noise and indicates that the [ADF4106](#) PLL loop locks at low frequency with a minimum increase in phase noise.

The actual measured phase noise of the PLL system is shown in Figure 4.

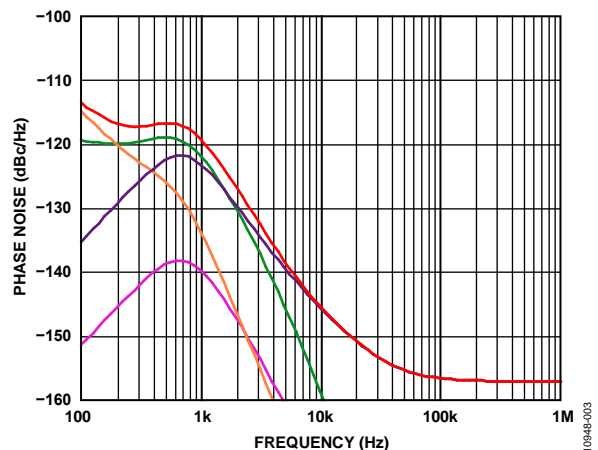

Figure 3. Simulated Phase Noise Plot from [ADIsimPLL](#)

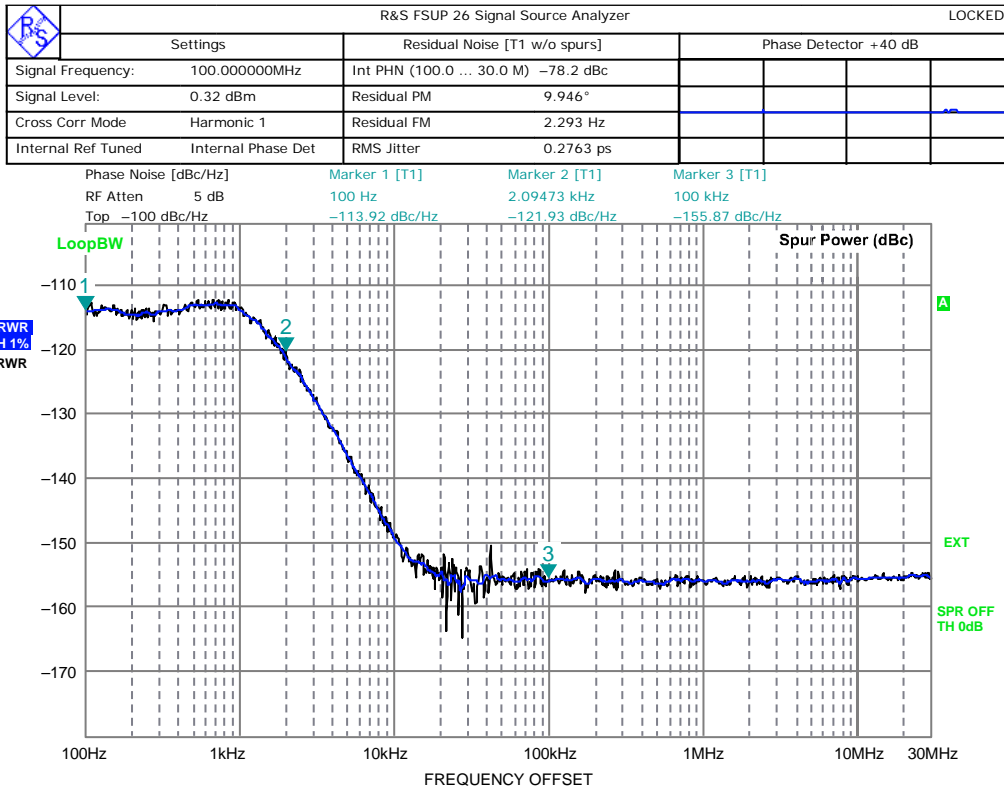

Figure 4. Measured Phase Noise Plot Using the Agilent FSSUP Spectrum Analyzer

The ADIsimPLL software used to generate the loop filter components can also be used to simulate the performance of the circuit. ADIsimPLL assumes an adequate signal slew rate and signal swing is provided by the REF<sub>IN</sub> and RF<sub>IN</sub> inputs. ADIsimPLL allows modeling the reference source used by the ADF4106 PLL, which for this setup is the R&S SMA100 signal generator.

The phase noise of the single-ended 10 MHz, 0 dBm reference input signal was modeled using the measured values at offsets of 10 Hz and 1 MHz. The Agilent FSUP spectrum analyzer was used to measure the reference phase noise at these offsets.

In order to simulate the VCO performance in ADIsimPLL, it is necessary to combine the phase noise from both the ADCLK925 datasheet and the CVSS-945 VCXO (Crystek Crystals, 12730 Commonwealth Drive, Fort Myers, Florida 33913) as shown in Table 1.

Table 1. Combined Phase Noise

Phase Noise Offset	ADCLK925 (dBc/Hz)	VCXO (dBc/Hz)	Total (dBc/Hz)
10 Hz	-140	-86	-86
1 MHz	-158	-172	-157

The combined 1/f phase noise is -86dBc/Hz at 10 Hz offset. The -140 dBc value at 10 Hz offset from the ADCLK925 datasheet will have negligible effect on the combined 1/f phase noise.

The combined phase noise is -157 dBc/Hz at an offset of 1 MHz .

The ADCLK925 phase noise at 1 MHz offset in the data sheet is -161 dBc/Hz. This is measured differentially, so it is necessary to adjust the datasheet measured noise floor by 3 dB when using a single-ended output. The VCXO phase noise of -172 dBc/Hz has an almost negligible contribution to the combined phase noise.

**Comparison of Measured vs. Simulated Results**

Table 2 shows simulated and measured results for phase noise and phase jitter. The phase noise is measured at offsets of 100 Hz, 2 kHz, and 100 kHz. Phase jitter is integrated from 100 Hz to 30 MHz. The ADIsimPLL program in this simulation uses a point floor model for the reference and VCO. As a result, the models in ADIsimPLL match very closely to the 1/f noise and the noise floor, but they can differ by several dB at intermediate offsets from the carrier.

Table 2. ADF4106 PLL System Simulated and Measured Phase Noise and Phase Jitter

Parameter	Simulated	Measured
PN Offset of 100 Hz dBc/Hz	-113 dBc/Hz	-114 dBc/Hz
PN Offset of 2 kHz dBc/Hz	-126 dBc/Hz	-122 dBc/Hz
PN Offset of 100 kHz dBc/Hz	-156 dBc/Hz	-156 dBc/Hz
Phase Jitter (100 Hz to 30 MHz)	208 fs	276 fs

## COMMON VARIATIONS

A single supply PECL/LVPECL comparator, such as the [ADCMP553](#), can be used for applications that require the REFIN to operate with signals having less than 10 V/ $\mu$ sec slew rates. The [ADCMP553](#) uses an output stage similar to the [ADCLK905/ADCLK925](#) to drive the REFIN/RFIN inputs, but the input of the comparator must be driven from a source impedance of 50  $\Omega$  with a common mode voltage that allows the required signal swing.

Other buffers such as the [ADCMP600](#) high speed CMOS comparator can be used to increase the slew rate for the REFIN circuit, however the additive jitter should be evaluated for the application in question.

All additional components will introduce some amount of additive noise, which can degrade the in-band phase noise and phase noise jitter. This may be acceptable for some applications, where the degradation in phase noise performance is still within the acceptable limits.

The [ADCLK9xx](#) family of clock buffers have very low additive jitter, however low slew rate signal inputs will degrade this specification. The [ADCLK9xx](#) data sheets should be consulted to evaluate this degradation.

A photo of the [EVAL-CN0290-SDPZ](#) circuit board is shown in Figure 5.

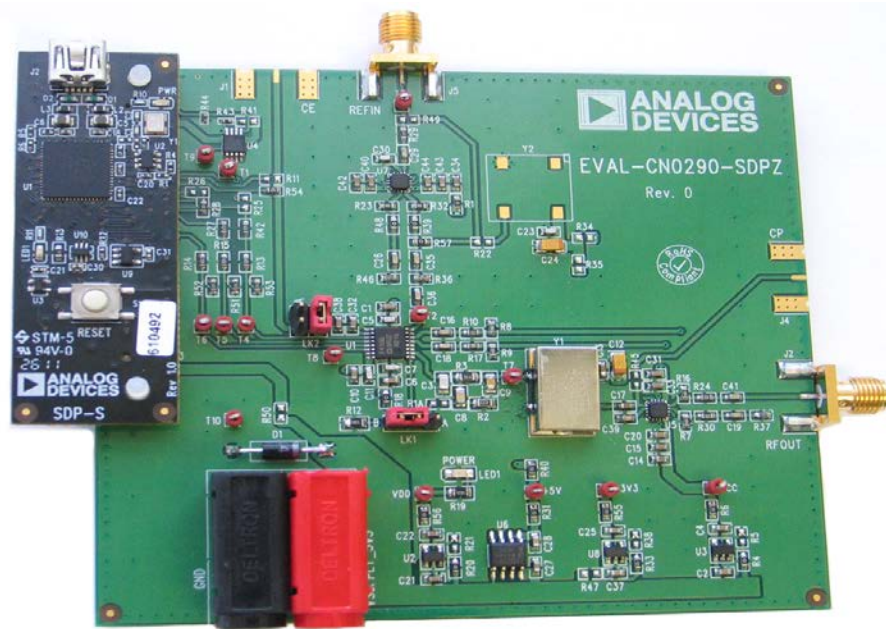

Figure 5. Photo of [EVAL-CN0290-SDPZ](#) Board Connected to the [EVAL-SDP-CS1Z](#) Board

10948-005

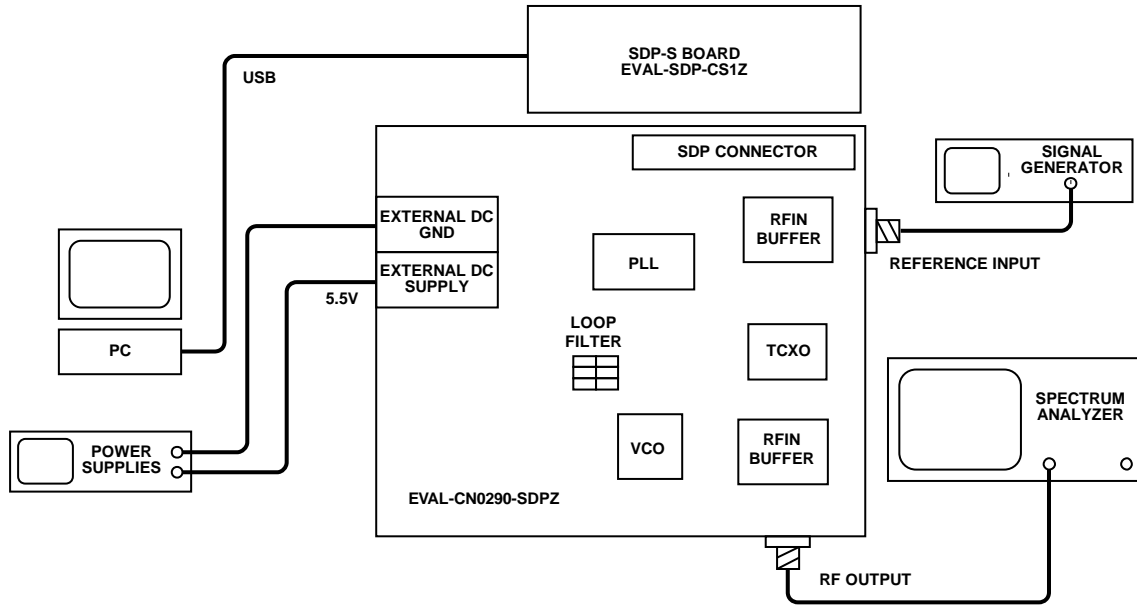

Figure 6. Measurement Setup for Phase Noise and Phase Jitter Testing

## CIRCUIT EVALUATION AND TEST

This circuit uses the [EVAL-CN0290-SDPZ](#) circuit board and the [EVAL-SDP-CS1Z](#) System Demonstration Platform (SDP-S) evaluation board. The two boards have a 120-pin mating connectors, allowing for the quick setup and evaluation of the circuit performance. The [EVAL-CN0290-SDPZ](#) board contains the circuit described in this note. The SDP-S evaluation board is used with the Integer N evaluation software to program the [ADF4106](#) on chip registers.

## Equipment needed

- PC with a USB port and Windows® XP, Windows Vista® (32-bit), or Windows® 7 (32-bit)
- [EVAL-CN0290-SDPZ](#) circuit evaluation board
- [EVAL-SDP-CS1Z](#) SDP evaluation board
- Integer-N v7 or greater evaluation software
- Power supply: +5.5 V.
- RF signal source (R&S SMA100 or equivalent)
- Spectrum Analyzer (Agilent FSUP or equivalent)
- Coaxial RF cables with SMA connectors

**Getting Started**

Refer to the [UG-582 User Guide](#) for software installation and test setup. The design support package includes the schematics, layout files, and the bill of materials ([www.analog.com/CN0290-DesignSupport](http://www.analog.com/CN0290-DesignSupport)). For additional details, refer to the [ADF4106](#), [ADCLK905](#), and the [ADCLK925](#) data sheets.

**Functional Block Diagram**

Refer to Figure 1 of this circuit note for the block diagram and Figure 2 for simplified schematic. A block diagram of the test setup is shown in Figure 6.

**Setup and Test**

After setting up the equipment, use standard RF test methods to measure the phase noise and phase jitter of the circuit.

**LEARN MORE**

CN0290 Design Support Package:

<http://www.analog.com/CN0290-DesignSupport>

[UG-582, User Guide, Evaluating the EVAL-CN0290-SDPZ](#)

[MT-031 Tutorial, Grounding Data Converters and Solving the Mystery of “AGND” and “DGND”, Analog Devices.](#)

[MT-086 Tutorial, Fundamentals of Phase Locked Loops \(PLLs\), Analog Devices.](#)

[MT-101 Tutorial, Decoupling Techniques, Analog Devices.](#)

[ADIsimPLL Design Tool](#)

[AN-30 Application Note, Ask the Application Engineer—PLL Synthesizers, Analog Devices](#)

[AN-586 Application Note, LVDS Data Outputs for High-Speed Analog-to-Digital Converters.](#)

**Data Sheets and Evaluation Boards**

[EVAL-CN0290-SDPZ Evaluation Board](#)

[EVAL-SDP-CS1Z System Development Platform](#)

[ADF4106 Data Sheet](#)

[ADCLK905 Data Sheet](#)

[ADCLK925 Data Sheet](#)

[ADP150 Data Sheet](#)

[ADP7102 Data Sheet](#)

[CVSS-945 VCXO, Crystek Crystals, 12730 Commonwealth Drive, Fort Myers, Florida 33913.](#)

**REVISION HISTORY**

8/13—Revision 0: Initial Version

(Continued from first page) Circuits from the Lab circuits are intended only for use with Analog Devices products and are the intellectual property of Analog Devices or its licensors. While you may use the Circuits from the Lab circuits in the design of your product, no other license is granted by implication or otherwise under any patents or other intellectual property by application or use of the Circuits from the Lab circuits. Information furnished by Analog Devices is believed to be accurate and reliable. However, Circuits from the Lab circuits are supplied "as is" and without warranties of any kind, express, implied, or statutory including, but not limited to, any implied warranty of merchantability, noninfringement or fitness for a particular purpose and no responsibility is assumed by Analog Devices for their use, nor for any infringements of patents or other rights of third parties that may result from their use. Analog Devices reserves the right to change any Circuits from the Lab circuits at any time without notice but is under no obligation to do so.

©2013 Analog Devices, Inc. All rights reserved. Trademarks and registered trademarks are the property of their respective owners.  
CN10948-0-8/13(0)





## Стандарт Электрон Связь

Мы молодая и активно развивающаяся компания в области поставок электронных компонентов. Мы поставляем электронные компоненты отечественного и импортного производства напрямую от производителей и с крупнейших складов мира.

Благодаря сотрудничеству с мировыми поставщиками мы осуществляем комплексные и плановые поставки широчайшего спектра электронных компонентов.

Собственная эффективная логистика и склад в обеспечивает надежную поставку продукции в точно указанные сроки по всей России.

Мы осуществляем техническую поддержку нашим клиентам и предпродажную проверку качества продукции. На все поставляемые продукты мы предоставляем гарантию .

Осуществляем поставки продукции под контролем ВП МО РФ на предприятия военно-промышленного комплекса России , а также работаем в рамках 275 ФЗ с открытием отдельных счетов в уполномоченном банке. Система менеджмента качества компании соответствует требованиям ГОСТ ISO 9001.

Минимальные сроки поставки, гибкие цены, неограниченный ассортимент и индивидуальный подход к клиентам являются основой для выстраивания долгосрочного и эффективного сотрудничества с предприятиями радиоэлектронной промышленности, предприятиями ВПК и научно-исследовательскими институтами России.

С нами вы становитесь еще успешнее!

### Наши контакты:

**Телефон:** +7 812 627 14 35

**Электронная почта:** [sales@st-electron.ru](mailto:sales@st-electron.ru)

**Адрес:** 198099, Санкт-Петербург,  
Промышленная ул, дом № 19, литера Н,  
помещение 100-Н Офис 331