



Is Now Part of



ON Semiconductor®

To learn more about ON Semiconductor, please visit our website at
www.onsemi.com

Please note: As part of the Fairchild Semiconductor integration, some of the Fairchild orderable part numbers will need to change in order to meet ON Semiconductor's system requirements. Since the ON Semiconductor product management systems do not have the ability to manage part nomenclature that utilizes an underscore (_), the underscore (_) in the Fairchild part numbers will be changed to a dash (-). This document may contain device numbers with an underscore (_). Please check the ON Semiconductor website to verify the updated device numbers. The most current and up-to-date ordering information can be found at www.onsemi.com. Please email any questions regarding the system integration to Fairchild_questions@onsemi.com.

ON Semiconductor and the ON Semiconductor logo are trademarks of Semiconductor Components Industries, LLC dba ON Semiconductor or its subsidiaries in the United States and/or other countries. ON Semiconductor owns the rights to a number of patents, trademarks, copyrights, trade secrets, and other intellectual property. A listing of ON Semiconductor's product/patent coverage may be accessed at www.onsemi.com/site/pdf/Patent-Marking.pdf. ON Semiconductor reserves the right to make changes without further notice to any products herein. ON Semiconductor makes no warranty, representation or guarantee regarding the suitability of its products for any particular purpose, nor does ON Semiconductor assume any liability arising out of the application or use of any product or circuit, and specifically disclaims any and all liability, including without limitation special, consequential or incidental damages. Buyer is responsible for its products and applications using ON Semiconductor products, including compliance with all laws, regulations and safety requirements or standards, regardless of any support or applications information provided by ON Semiconductor. "Typical" parameters which may be provided in ON Semiconductor data sheets and/or specifications can and do vary in different applications and actual performance may vary over time. All operating parameters, including "Typicals" must be validated for each customer application by customer's technical experts. ON Semiconductor does not convey any license under its patent rights nor the rights of others. ON Semiconductor products are not designed, intended, or authorized for use as a critical component in life support systems or any FDA Class 3 medical devices or medical devices with a same or similar classification in a foreign jurisdiction or any devices intended for implantation in the human body. Should Buyer purchase or use ON Semiconductor products for any such unintended or unauthorized application, Buyer shall indemnify and hold ON Semiconductor and its officers, employees, subsidiaries, affiliates, and distributors harmless against all claims, costs, damages, and expenses, and reasonable attorney fees arising out of, directly or indirectly, any claim of personal injury or death associated with such unintended or unauthorized use, even if such claim alleges that ON Semiconductor was negligent regarding the design or manufacture of the part. ON Semiconductor is an Equal Opportunity/Affirmative Action Employer. This literature is subject to all applicable copyright laws and is not for resale in any manner.



February 2016

FOD3120

High Noise Immunity, 2.5 A Output Current, Gate Drive Optocoupler

Features

- High Noise Immunity Characterized by 35 kV/ μ s Minimum Common Mode Rejection
- 2.5 A Peak Output Current Driving Capability for Most 1200 V/20 A IGBT
- Use of P-channel MOSFETs at Output Stage Enables Output Voltage Swing Close to The Supply Rail
- Wide Supply Voltage Range from 15 V to 30 V
- Fast Switching Speed
 - 400 ns max. Propagation Delay
 - 100 ns max. Pulse Width Distortion
- Under Voltage LockOut (UVLO) with Hysteresis
- Extended Industrial Temperature Range, -40°C to 100°C Temperature Range
- Safety and Regulatory Approved
 - UL1577, 5000 V_{RMS} for 1 min.
 - DIN EN/IEC60747-5-5
- R_{DS(ON)} of 1 Ω (typ.) Offers Lower Power Dissipation
- >8.0 mm Clearance and Creepage Distance (Option 'T' or 'TS')
- 1,414 V Peak Working Insulation Voltage (V_{IORM})

Applications

- Industrial Inverter
- Uninterruptible Power Supply
- Induction Heating
- Isolated IGBT/Power MOSFET Gate Drive

Description

The FOD3120 is a 2.5 A Output Current Gate Drive Optocoupler, capable of driving most medium power IGBT/MOSFET. It is ideally suited for fast switching driving of power IGBT and MOSFETs used in motor control inverter applications, and high performance power system.

It utilizes Fairchild's coplanar packaging technology, Optoplanar[®], and optimized IC design to achieve high noise immunity, characterized by high common mode rejection.

It consists of a gallium aluminum arsenide (AlGaAs) light emitting diode optically coupled to an integrated circuit with a high-speed driver for push-pull MOSFET output stage.

Related Resources

- FOD3150, 1 A Output Current, Gate Drive Optocoupler Datasheet
- www.fairchildsemi.com/products/optoelectronics/

Functional Block Diagram

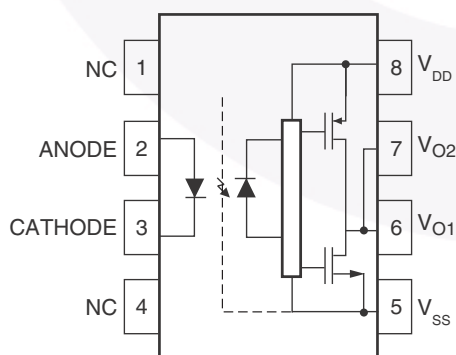

Figure 1. Functional Block Diagram⁽¹⁾

Note:

1. 0.1 μ F bypass capacitor must be connected between pins 5 and 8.

Package Outlines

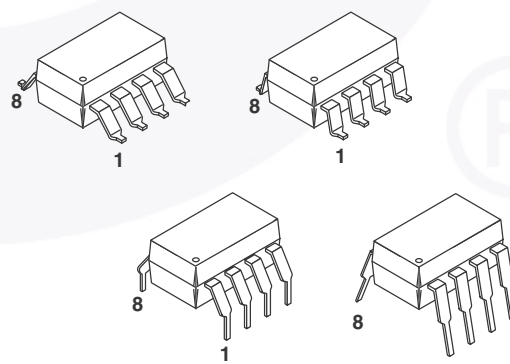

Figure 2. Package Outlines

Truth Table

LED	$V_{DD} - V_{SS}$ "Positive Going" (Turn-on)	$V_{DD} - V_{SS}$ "Negative Going" (Turn-off)	V_o
Off	0 V to 30 V	0 V to 30 V	Low
On	0 V to 11.5 V	0 V to 10 V	Low
On	11.5 V to 13.5 V	10 V to 12 V	Transition
On	13.5 V to 30 V	12 V to 30 V	High

Pin Definitions

Pin #	Name	Description
1	NC	Not Connected
2	Anode	LED Anode
3	Cathode	LED Cathode
4	NC	Not Connected
5	V_{SS}	Negative Supply Voltage
6	V_{O2}	Output Voltage 2 (internally connected to V_{O1})
7	V_{O1}	Output Voltage 1
8	V_{DD}	Positive Supply Voltage

Safety and Insulation Ratings

As per DIN EN/IEC 60747-5-5, this optocoupler is suitable for “safe electrical insulation” only within the safety limit data. Compliance with the safety ratings shall be ensured by means of protective circuits.

Parameter	Characteristics	
Installation Classifications per DIN VDE 0110/1.89 Table 1, For Rated Mains Voltage	< 150 V _{RMS}	I–IV
	< 300 V _{RMS}	I–IV
	< 450 V _{RMS}	I–III
	< 600 V _{RMS}	I–III
	< 1000 V _{RMS} (Option T, TS)	I–III
Climatic Classification	40/100/21	
Pollution Degree (DIN VDE 0110/1.89)	2	
Comparative Tracking Index	175	

Symbol	Parameter	Value	Unit
V _{PR}	Input-to-Output Test Voltage, Method A, V _{IORM} × 1.6 = V _{PR} , Type and Sample Test with t _m = 10 s, Partial Discharge < 5 pC	2,262	V _{peak}
	Input-to-Output Test Voltage, Method B, V _{IORM} × 1.875 = V _{PR} , 100% Production Test with t _m = 1 s, Partial Discharge < 5 pC	2,651	V _{peak}
V _{IORM}	Maximum Working Insulation Voltage	1,414	V _{peak}
V _{IOTM}	Highest Allowable Over-Voltage	6,000	V _{peak}
	External Creepage	≥ 8.0	mm
	External Clearance	≥ 7.4	mm
	External Clearance (for Option T or TS, 0.4" Lead Spacing)	≥ 10.16	mm
DTI	Distance Through Insulation (Insulation Thickness)	≥ 0.5	mm
T _S	Case Temperature ⁽²⁾	175	°C
I _{S,INPUT}	Input Current ⁽²⁾	400	mA
P _{S,OUTPUT}	Output Power (Duty Factor ≤ 2.7%) ⁽²⁾	700	mW
R _{IO}	Insulation Resistance at T _S , V _{IO} = 500 V ⁽²⁾	> 10 ⁹	Ω

Note:

2. Safety limit value - maximum values allowed in the event of a failure.

Absolute Maximum Ratings ($T_A = 25^\circ\text{C}$ unless otherwise specified)

Stresses exceeding the absolute maximum ratings may damage the device. The device may not function or be operable above the recommended operating conditions and stressing the parts to these levels is not recommended. In addition, extended exposure to stresses above the recommended operating conditions may affect device reliability. The absolute maximum ratings are stress ratings only.

Symbol	Parameter	Value	Unit
T_{STG}	Storage Temperature	-55 to +125	$^\circ\text{C}$
T_{OPR}	Operating Temperature	-40 to +100	$^\circ\text{C}$
T_J	Junction Temperature	-40 to +125	$^\circ\text{C}$
T_{SOL}	Lead Wave Solder Temperature (refer to page 21 for reflow solder profile)	260 for 10sec	$^\circ\text{C}$
$I_{F(AVG)}$	Average Input Current	25	mA
$I_{F(PEAK)}$	Peak Transient Forward Current ⁽³⁾	1	A
f	Operating Frequency ⁽⁴⁾	50	kHz
V_R	Reverse Input Voltage	5	V
$I_{O(PEAK)}$	Peak Output Current ⁽⁵⁾	3.0	A
$V_{DD} - V_{SS}$	Supply Voltage	$T_A < 90^\circ\text{C}$	0 to 35
		$T_A \geq 90^\circ\text{C}$	0 to 30
$V_{O(PEAK)}$	Peak Output Voltage	0 to V_{DD}	V
$t_{R(IN)}, t_{F(IN)}$	Input Signal Rise and Fall Time	500	ns
PD_I	Input Power Dissipation ⁽⁶⁾⁽⁸⁾	45	mW
PD_O	Output Power Dissipation ⁽⁷⁾⁽⁸⁾	250	mW

Notes:

- Pulse Width, $P_W \leq 1 \mu\text{s}$, 300 pps
- Exponential Waveform, $I_{O(PEAK)} \leq |2.5 \text{ A}| (\leq 0.3 \mu\text{s})$
- Maximum pulse width = 10 μs , maximum duty cycle = 1.1%
- Derate linearly above 87 $^\circ\text{C}$, free air temperature at a rate of 0.77 mW/ $^\circ\text{C}$
- No derating required across temperature range.
- Functional operation under these conditions is not implied. Permanent damage may occur if the device is subjected to conditions outside these ratings.

Recommended Operating Conditions

The Recommended Operating Conditions table defines the conditions for actual device operation. Recommended operating conditions are specified to ensure optimal performance to the datasheet specifications. Fairchild does not recommend exceeding them or designing to absolute maximum ratings.

Symbol	Parameter	Value	Unit
T_A	Ambient Operating Temperature	-40 to +100	$^\circ\text{C}$
$V_{DD} - V_{SS}$	Power Supply	15 to 30	V
$I_{F(ON)}$	Input Current (ON)	7 to 16	mA
$V_{F(OFF)}$	Input Voltage (OFF)	0 to 0.8	V

Isolation Characteristics

Apply over all recommended conditions, typical value is measured at $T_A = 25^\circ\text{C}$

Symbol	Parameter	Conditions	Min.	Typ.	Max.	Unit
V_{ISO}	Input-Output Isolation Voltage	$T_A = 25^\circ\text{C}$, R.H. < 50%, $t = 1.0\text{min}$, $I_{I-O} \leq 10 \mu\text{A}$, 50 Hz ⁽⁹⁾⁽¹⁰⁾	5,000			V_{RMS}
R_{ISO}	Isolation Resistance	$V_{I-O} = 500 \text{V}^{(9)}$		10^{11}		Ω
C_{ISO}	Isolation Capacitance	$V_{I-O} = 0 \text{V}$, Freq = 1.0 MHz ⁽⁹⁾		1		pF

Notes:

9. Device is considered a two terminal device: Pins 2 and 3 are shorted together and Pins 5, 6, 7 and 8 are shorted together.

10. 5,000 V_{RMS} for 1 minute duration is equivalent to 6,000 V_{ACRMS} for 1 second duration.

Electrical Characteristics

Apply over all recommended conditions, typical value is measured at $V_{DD} = 30 \text{V}$, $V_{SS} = \text{Ground}$, $T_A = 25^\circ\text{C}$ unless otherwise specified.

Symbol	Parameter	Conditions	Min.	Typ.	Max.	Unit
V_F	Input Forward Voltage	$I_F = 10 \text{mA}$	1.2	1.5	1.8	V
$\Delta(V_F / T_A)$	Temperature Coefficient of Forward Voltage			-1.8		mV/ $^\circ\text{C}$
BV_R	Input Reverse Breakdown Voltage	$I_R = 10 \mu\text{A}$	5			V
C_{IN}	Input Capacitance	$f = 1 \text{MHz}$, $V_F = 0\text{V}$		60		pF
I_{OH}	High Level Output Current ⁽⁴⁾	$V_O = V_{DD} - 3 \text{V}$	-1.0	-2.0	-2.5	A
		$V_O = V_{DD} - 6 \text{V}$	-2.0		-2.5	
I_{OL}	Low Level Output Current ⁽⁴⁾	$V_O = V_{SS} + 3 \text{V}$	1.0	2.0	2.5	A
		$V_O = V_{SS} + 6 \text{V}$	2.0		2.5	
V_{OH}	High Level Output Voltage	$I_F = 10 \text{mA}$, $I_O = -2.5 \text{A}$	$V_{DD} - 6.25 \text{V}$	$V_{DD} - 2.5 \text{V}$		V
		$I_F = 10 \text{mA}$, $I_O = -100 \text{mA}$	$V_{DD} - 0.25 \text{V}$	$V_{DD} - 0.1 \text{V}$		
V_{OL}	Low Level Output Voltage	$I_F = 0 \text{mA}$, $I_O = 2.5 \text{A}$		$V_{SS} + 2.5 \text{V}$	$V_{SS} + 6.25 \text{V}$	V
		$I_F = 0 \text{mA}$, $I_O = 100 \text{mA}$		$V_{SS} + 0.1 \text{V}$	$V_{SS} + 0.25 \text{V}$	
I_{DDH}	High Level Supply Current	$V_O = \text{Open}$, $I_F = 7 \text{ to } 16 \text{mA}$		2.8	3.8	mA
I_{DDL}	Low Level Supply Current	$V_O = \text{Open}$, $V_F = 0 \text{ to } 0.8 \text{V}$		2.8	3.8	mA
I_{FLH}	Threshold Input Current Low to High	$I_O = 0 \text{mA}$, $V_O > 5 \text{V}$		2.3	5.0	mA
V_{FHL}	Threshold Input Voltage High to Low	$I_O = 0 \text{mA}$, $V_O < 5 \text{V}$	0.8			V
V_{UVLO+}	Under Voltage Lockout Threshold	$I_F = 10 \text{mA}$, $V_O > 5 \text{V}$	11.5	12.7	13.5	V
V_{UVLO-}		$I_F = 10 \text{mA}$, $V_O < 5 \text{V}$	10.0	11.2	12.0	V
$UVLO_{HYS}$	Under Voltage Lockout Threshold Hysteresis			1.5		V

Switching Characteristics

Apply over all recommended conditions, typical value is measured at $V_{DD} = 30\text{ V}$, $V_{SS} = \text{Ground}$, $T_A = 25^\circ\text{C}$ unless otherwise specified.

Symbol	Parameter	Conditions	Min.	Typ.	Max.	Unit
t_{PHL}	Propagation Delay Time to Logic Low Output	$I_F = 7\text{ mA to }16\text{ mA}$, $R_g = 10\ \Omega$, $C_g = 10\text{ nF}$, $f = 10\text{ kHz}$, Duty Cycle = 50%	150	275	400	ns
t_{PLH}	Propagation Delay Time to Logic High Output		150	255	400	ns
PWD	Pulse Width Distortion, $ t_{PHL} - t_{PLH} $			20	100	ns
PDD (Skew)	Propagation Delay Difference Between Any Two Parts or Channels, $(t_{PHL} - t_{PLH})^{(11)}$			-250	250	ns
t_R	Output Rise Time (10% – 90%)				60	ns
t_F	Output Fall Time (90% – 10%)				60	ns
$t_{UVLO\ ON}$	UVLO Turn On Delay		$I_F = 10\text{ mA}$, $V_O > 5\text{ V}$		1.6	
$t_{UVLO\ OFF}$	UVLO Turn Off Delay	$I_F = 10\text{ mA}$, $V_O < 5\text{ V}$		0.4		μs
$ CM_H $	Common Mode Transient Immunity at Output High	$T_A = 25^\circ\text{C}$, $V_{DD} = 30\text{ V}$, $I_F = 7\text{ to }16\text{ mA}$, $V_{CM} = 2000\text{ V}^{(12)}$	35	50		$\text{kV}/\mu\text{s}$
$ CM_L $	Common Mode Transient Immunity at Output Low	$T_A = 25^\circ\text{C}$, $V_{DD} = 30\text{ V}$, $V_F = 0\text{ V}$, $V_{CM} = 2000\text{ V}^{(13)}$	35	50		$\text{kV}/\mu\text{s}$

Notes:

- The difference between t_{PHL} and t_{PLH} between any two FOD3120 parts under same test conditions.
- Common mode transient immunity at output high is the maximum tolerable negative dV_{cm}/dt on the trailing edge of the common mode impulse signal, V_{cm} , to assure that the output will remain high (i.e. $V_O > 15.0\text{ V}$).
- Common mode transient immunity at output low is the maximum tolerable positive dV_{cm}/dt on the leading edge of the common pulse signal, V_{cm} , to assure that the output will remain low (i.e. $V_O < 1.0\text{ V}$).

Typical Performance Characteristics

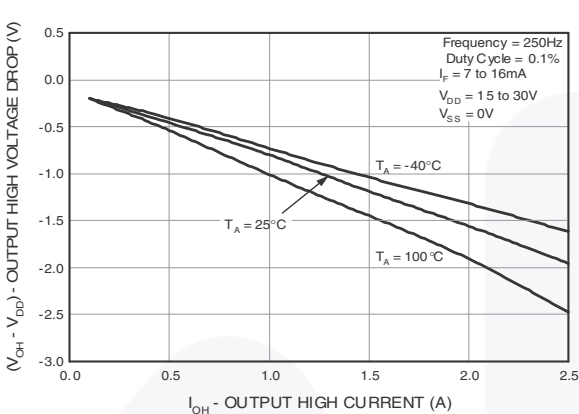

Fig. 3 Output High Voltage Drop vs. Output High Current

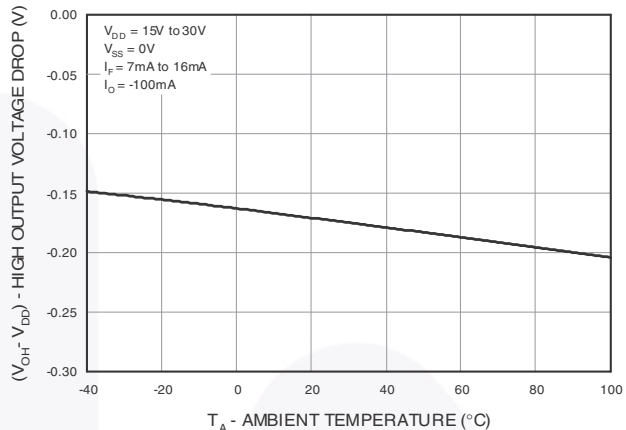

Fig. 4 Output High Voltage Drop vs. Ambient Temperature

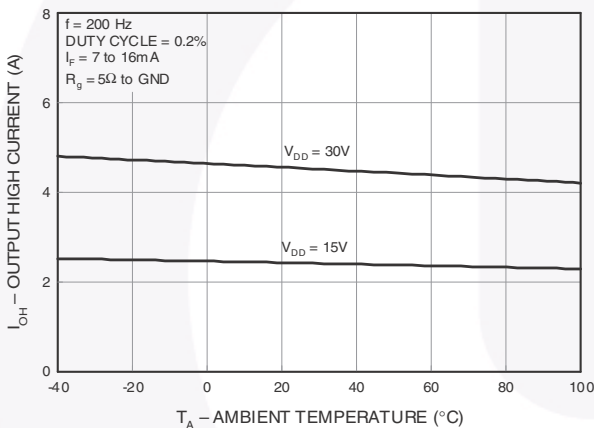

Fig. 5 Output High Current vs. Ambient Temperature

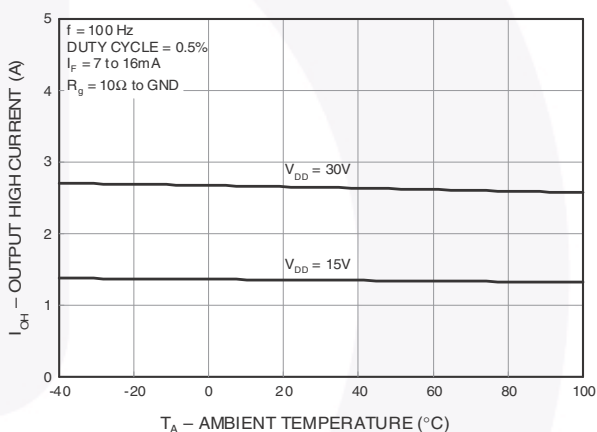

Fig. 6 Output High Current vs. Ambient Temperature

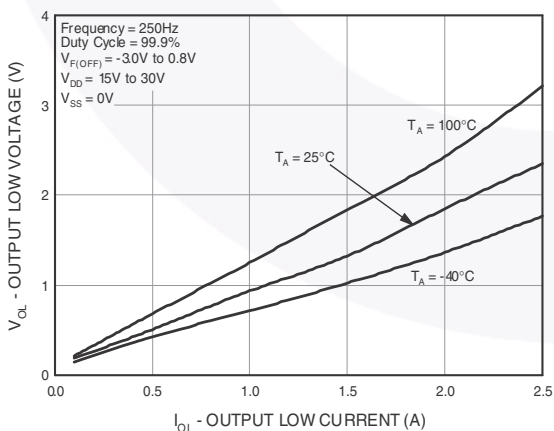

Fig. 7 Output Low Voltage vs. Output Low Current

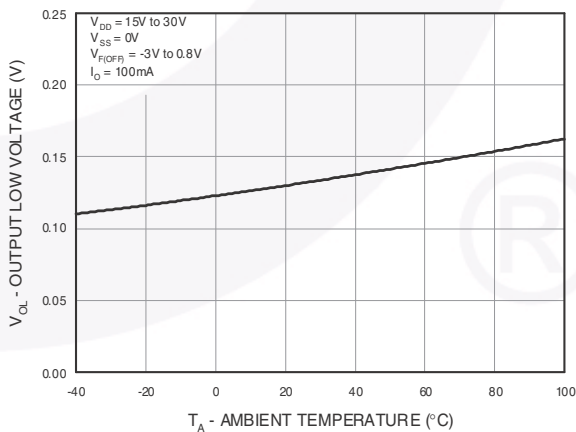

Fig. 8 Output Low Voltage vs. Ambient Temperature

Typical Performance Characteristics (Continued)

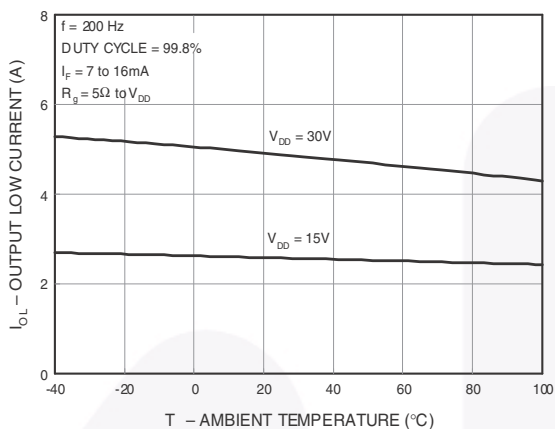

Fig. 9 Output Low Current vs. Ambient Temperature

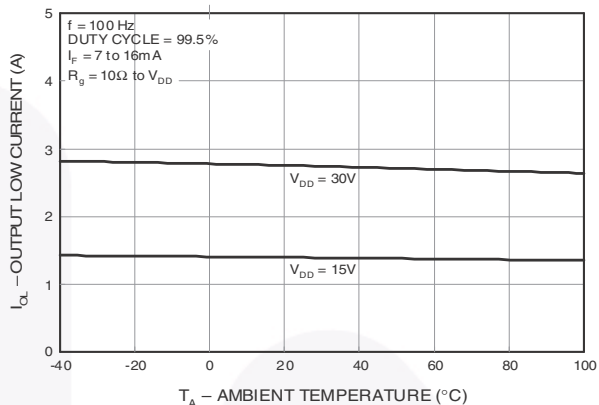

Fig. 10 Output Low Current vs. Ambient Temperature

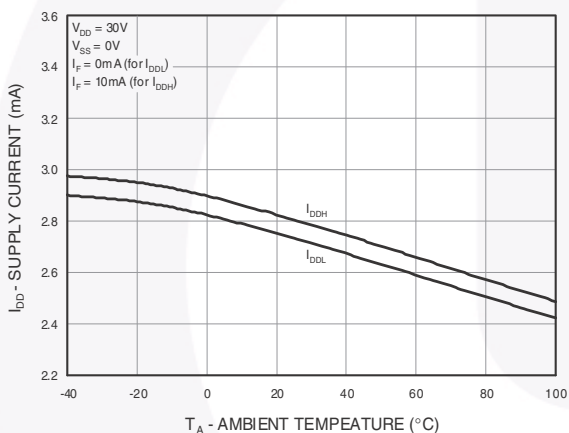

Fig. 11 Supply Current vs. Ambient Temperature

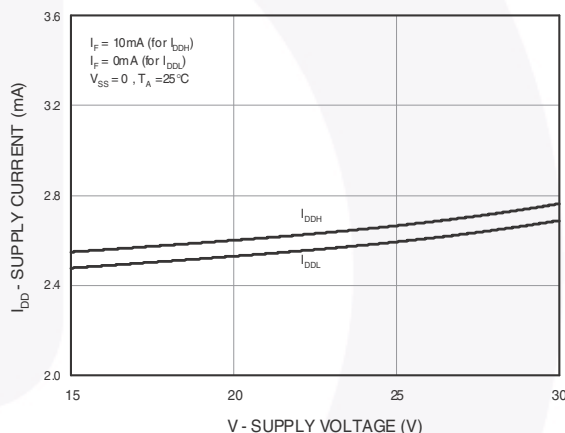

Fig. 12 Supply Current vs. Supply Voltage

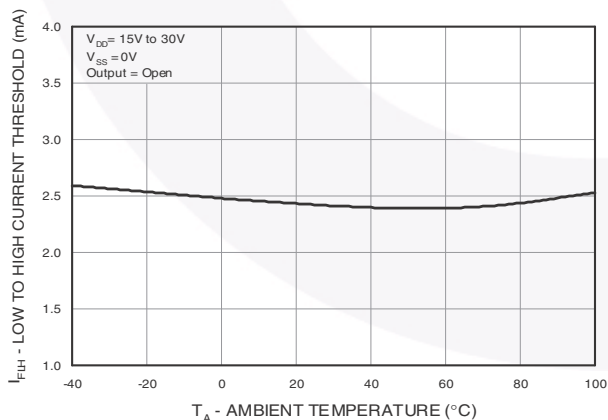

Fig. 13 Low to High Input Current Threshold vs. Ambient Temperature

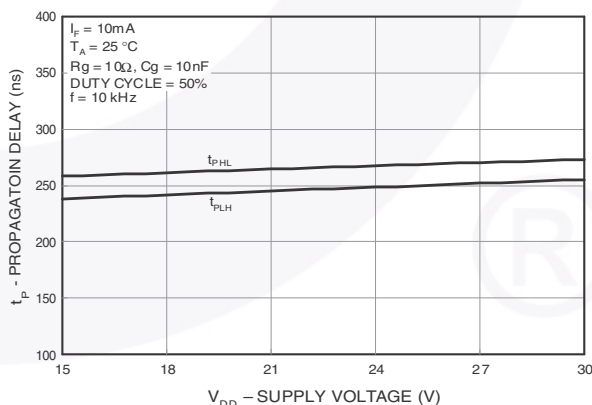

Fig. 14 Propagation Delay vs. Supply Voltage

Typical Performance Characteristics (Continued)

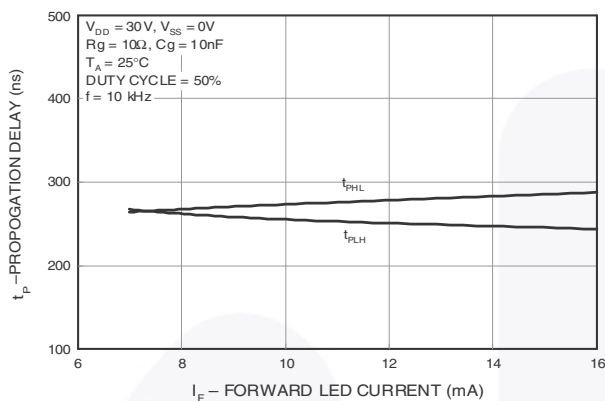

Fig. 15 Propagation Delay vs. LED Forward Current

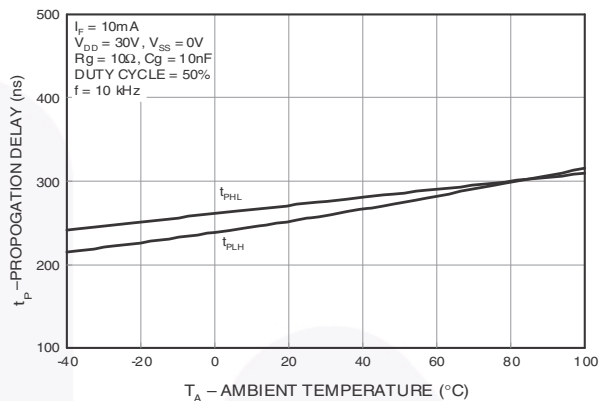

Fig. 16 Propagation Delay vs. Ambient Temperature

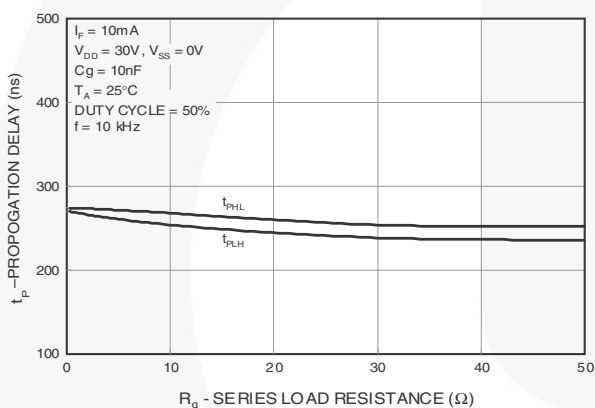

Fig. 17 Propagation Delay vs. Series Load Resistance

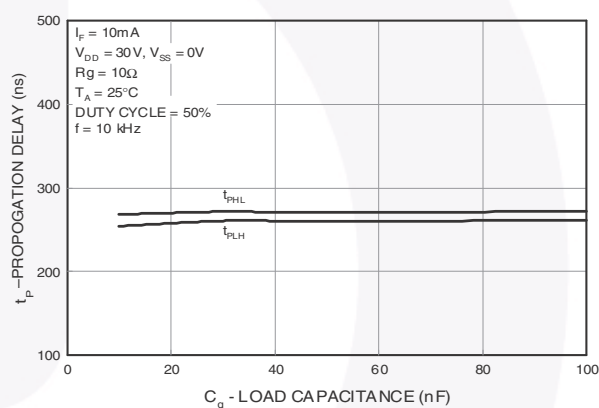

Fig. 18 Propagation Delay vs. Load Capacitance

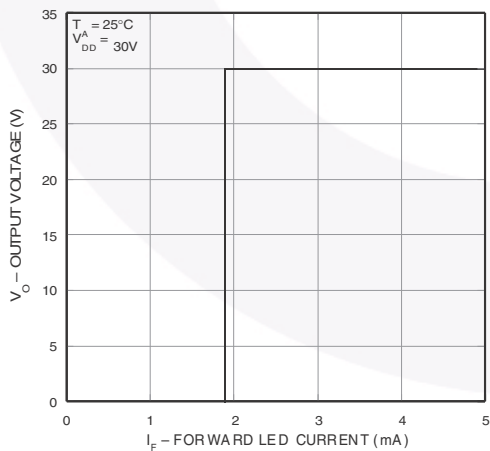

Fig. 19 Transfer Characteristics

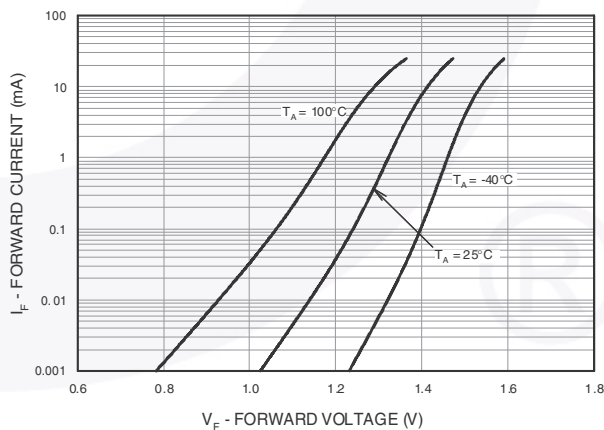

Fig. 20 Input Forward Current vs. Forward Voltage

Typical Performance Characteristics (Continued)

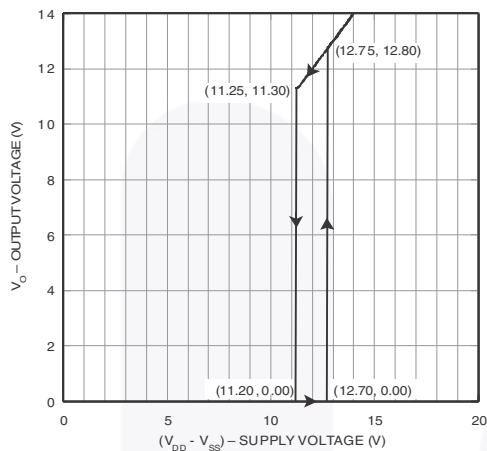

Fig. 21 Under Voltage Lockout



Test Circuit

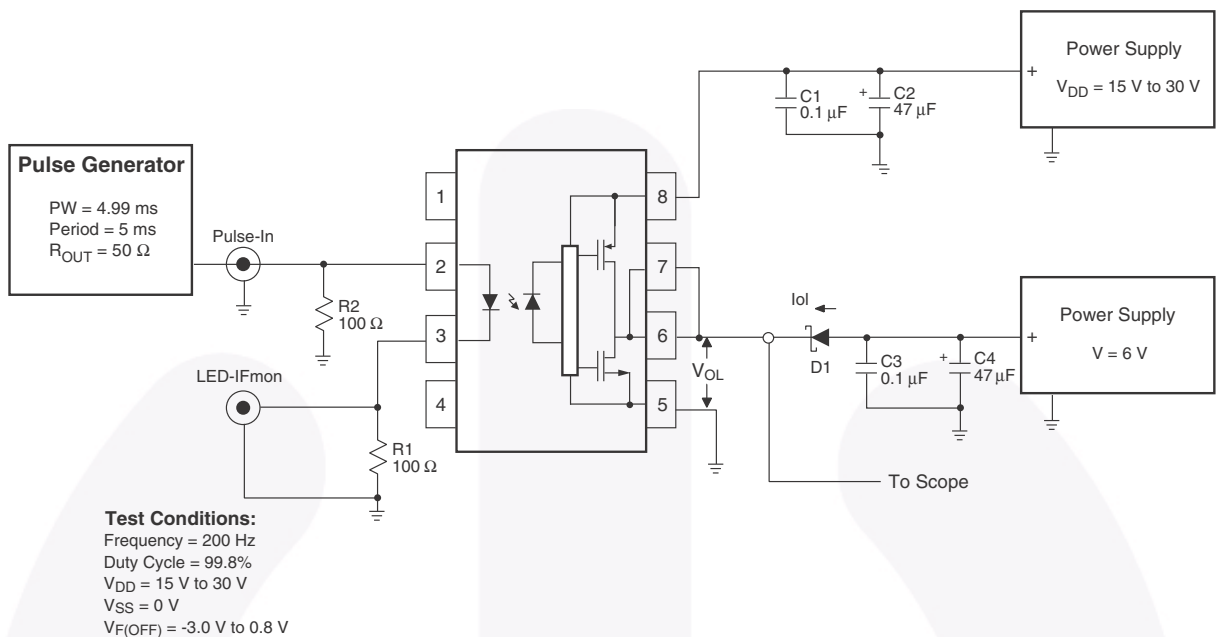

Figure 22. I_{OL} Test Circuit

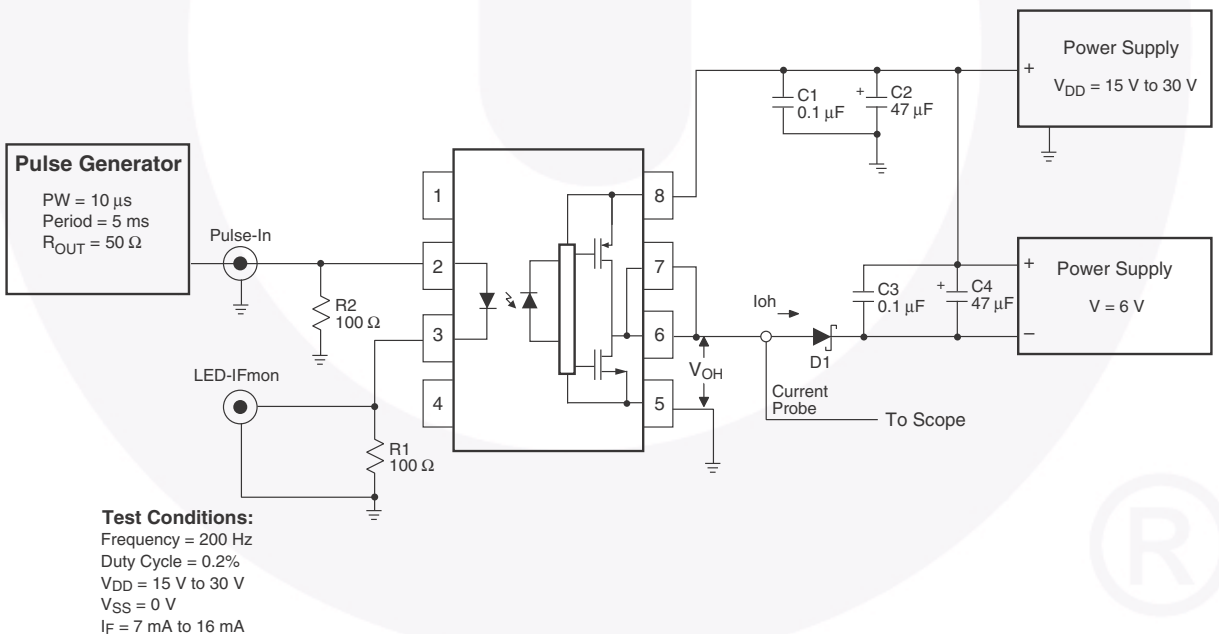

Figure 23. I_{OH} Test Circuit

Test Circuit (Continued)

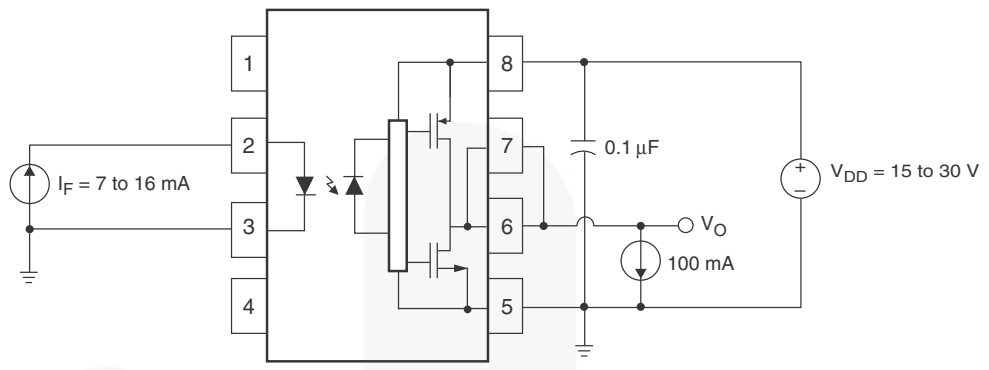

Figure 24. V_{OH} Test Circuit

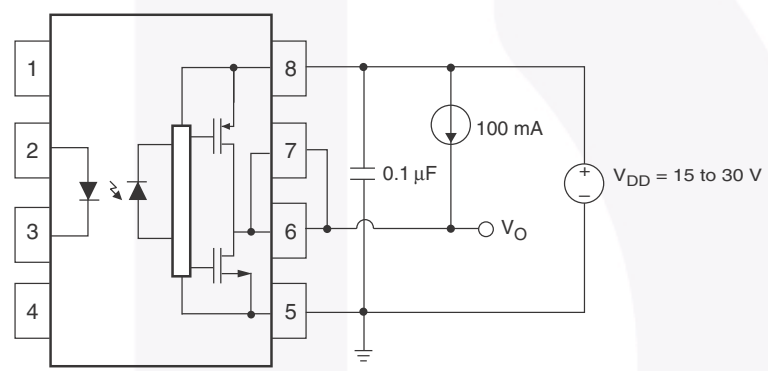

Figure 25. V_{OL} Test Circuit



Test Circuit (Continued)

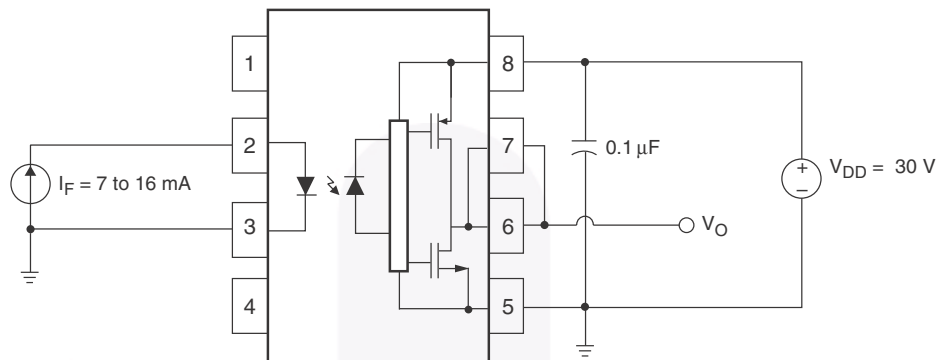

Figure 26. I_{DDH} Test Circuit

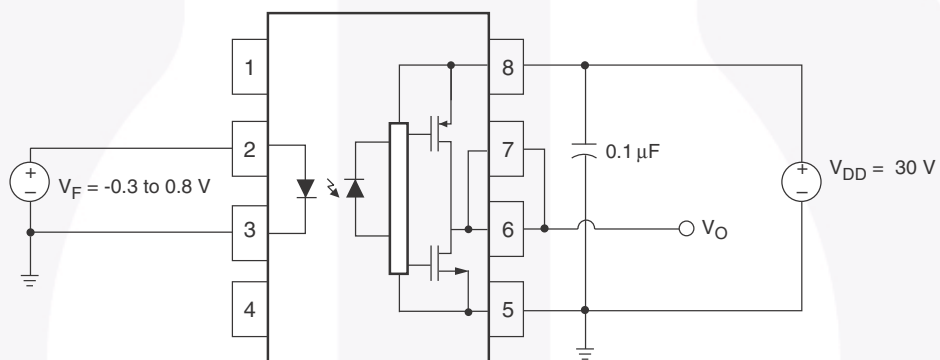

Figure 27. I_{DDL} Test Circuit



Test Circuit (Continued)

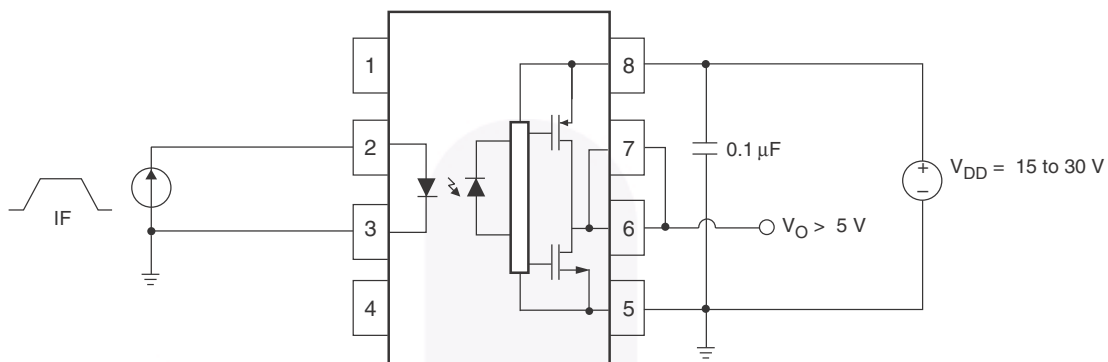

Figure 28. I_{FLH} Test Circuit

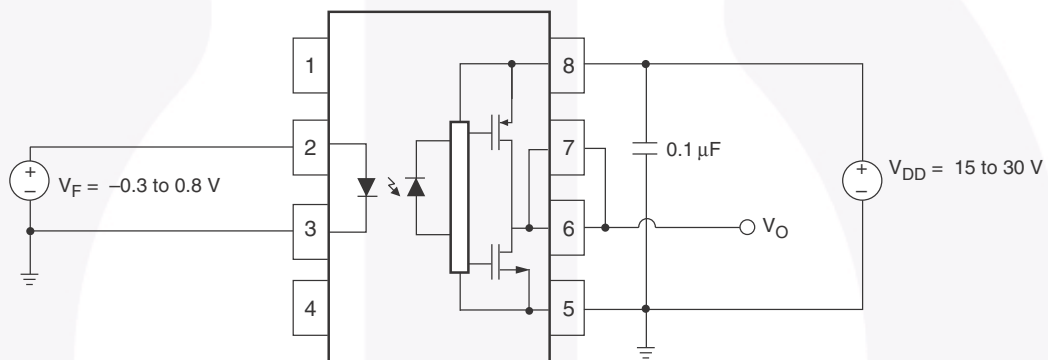

Figure 29. V_{FHL} Test Circuit

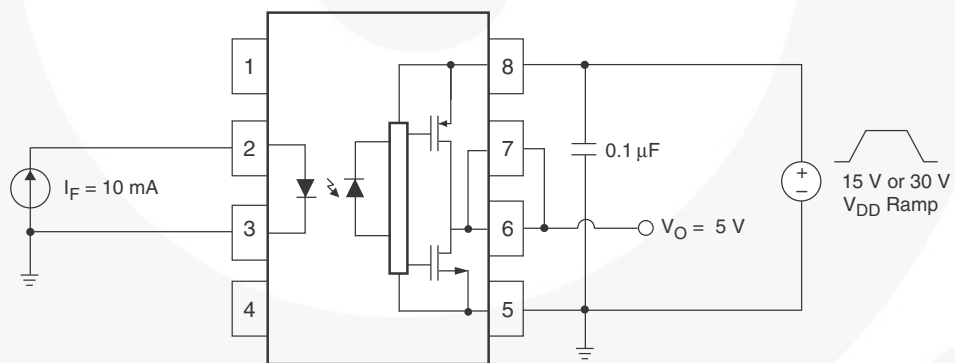

Figure 30. UVLO Test Circuit

Test Circuit (Continued)

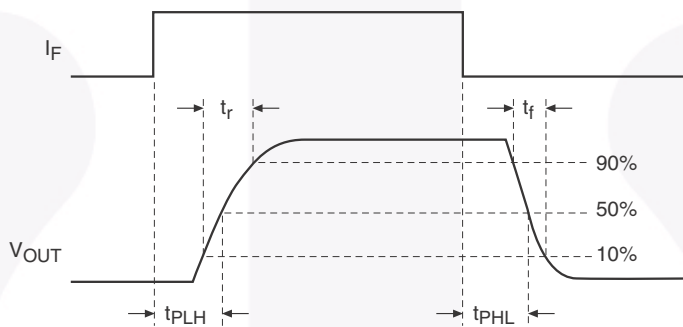
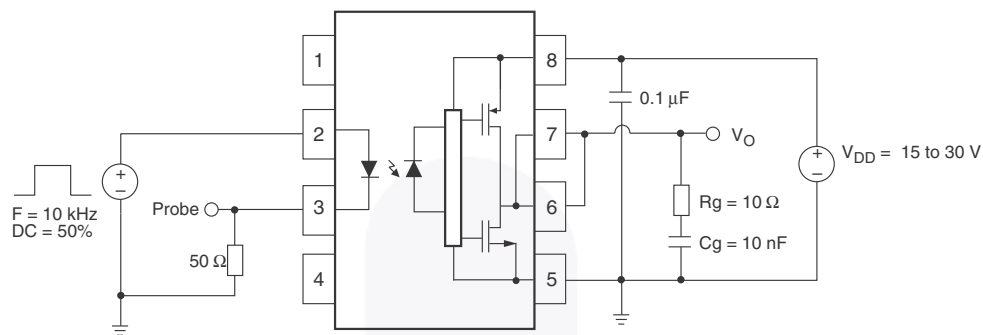

Figure 31. t_{PHL} , t_{PLH} , t_R and t_F Test Circuit and Waveforms

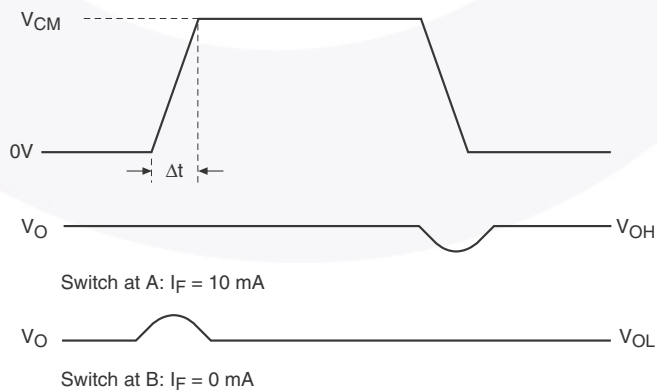
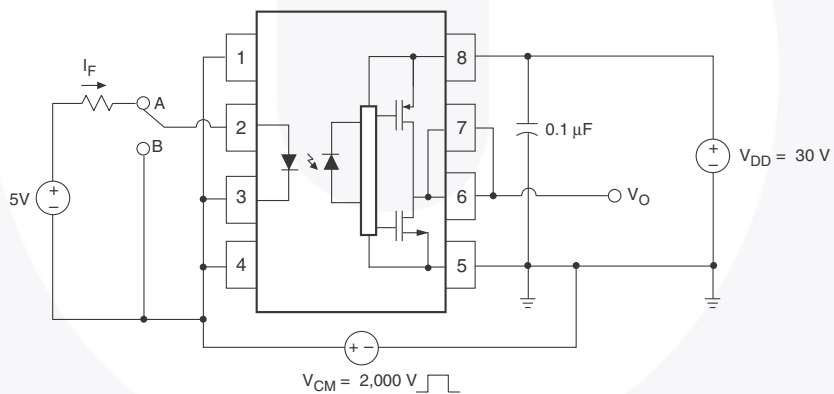
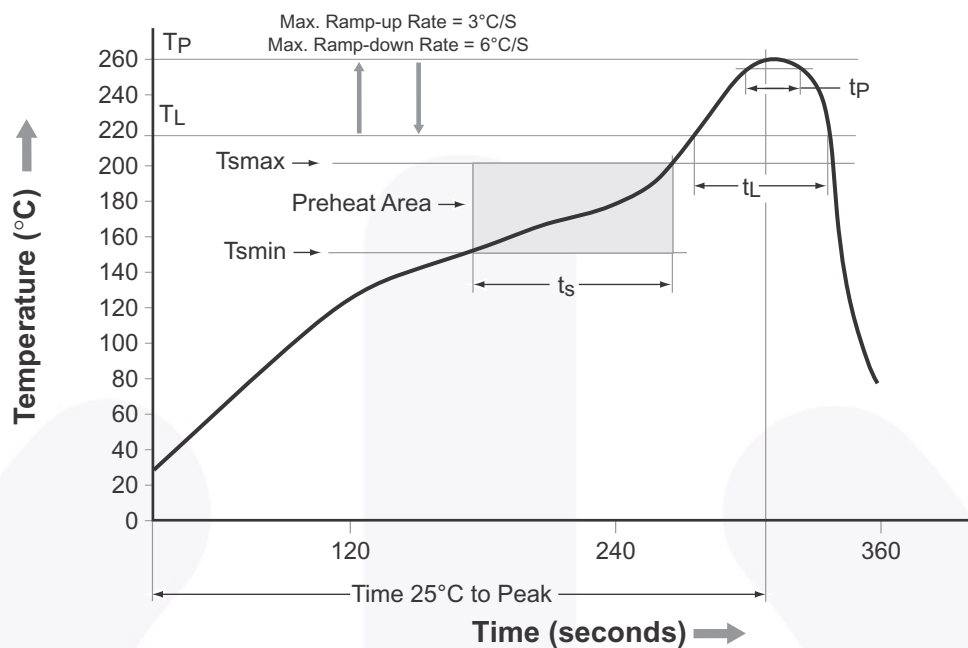

Figure 32. CMR Test Circuit and Waveforms

Reflow Profile



Profile Feature	Pb-Free Assembly Profile
Temperature Min. (T _{smín})	150°C
Temperature Max. (T _{smáx})	200°C
Time (t _s) from (T _{smín} to T _{smáx})	60–120 seconds
Ramp-up Rate (t _L to t _p)	3°C/second max.
Liquidous Temperature (T _L)	217°C
Time (t _L) Maintained Above (T _L)	60–150 seconds
Peak Body Package Temperature	260°C +0°C / -5°C
Time (t _p) within 5°C of 260°C	30 seconds
Ramp-down Rate (T _p to T _L)	6°C/second max.
Time 25°C to Peak Temperature	8 minutes max.

Ordering Information

Part Number	Package	Packing Method
FOD3120	DIP 8-Pin	Tube (50 units per tube)
FOD3120S	SMT 8-Pin (Lead Bend)	Tube (50 units per tube)
FOD3120SD	SMT 8-Pin (Lead Bend)	Tape and Reel (1,000 units per reel)
FOD3120V	DIP 8-Pin, DIN_EN/IEC60747-5-5 option	Tube (50 units per tube)
FOD3120SV	SMT 8-Pin (Lead Bend), DIN_EN/IEC60747-5-5 option	Tube (50 units per tube)
FOD3120SDV	SMT 8-Pin (Lead Bend), DIN_EN/IEC60747-5-5 option	Tape and Reel (1,000 units per reel)
FOD3120TV	DIP 8-Pin, 0.4" Lead Spacing, DIN_EN/IEC60747-5-5 option	Tube (50 units per tube)
FOD3120TSV	SMT 8-Pin, 0.4" Lead Spacing, DIN_EN/IEC60747-5-5 option	Tube (50 units per tube)
FOD3120TSR2V	SMT 8-Pin, 0.4" Lead Spacing, DIN_EN/IEC60747-5-5 option	Tape and Reel (700 units per reel)

Marking Information

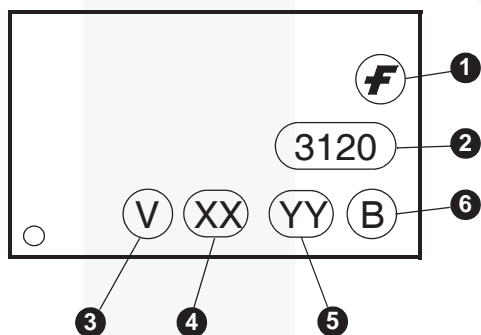
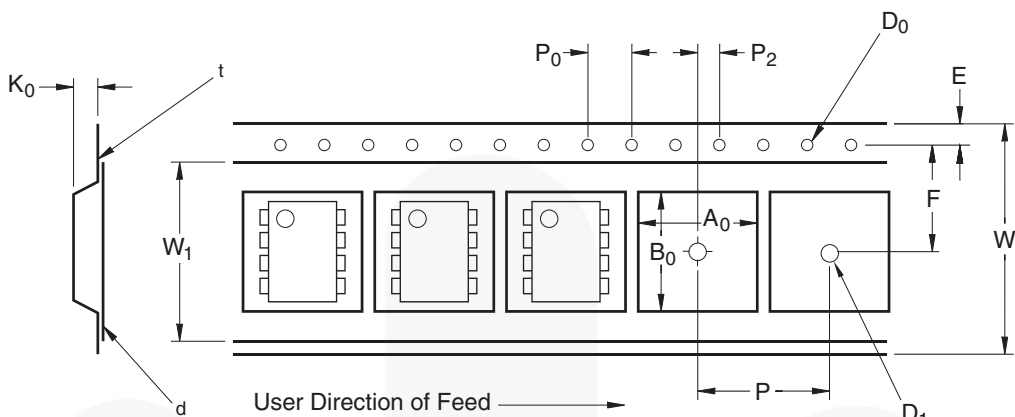

Figure 33. Top Mark

Definitions	
1	Fairchild logo
2	Device number
3	DIN_EN/IEC60747-5-5 Option (only appears on component ordered with this option)
4	Two digit year code, e.g., '16'
5	Two digit work week ranging from '01' to '53'
6	Assembly package code

Carrier Tape Specifications (Option SD)



Symbol	Description	Dimension in mm
W	Tape Width	16.0 ± 0.3
t	Tape Thickness	0.30 ± 0.05
P ₀	Sprocket Hole Pitch	4.0 ± 0.1
D ₀	Sprocket Hole Diameter	1.55 ± 0.05
E	Sprocket Hole Location	1.75 ± 0.10
F	Pocket Location	7.5 ± 0.1
P ₂		2.0 ± 0.1
P	Pocket Pitch	12.0 ± 0.1
A ₀	Pocket Dimensions	10.30 ± 0.20
B ₀		10.30 ± 0.20
K ₀		4.90 ± 0.20
W ₁	Cover Tape Width	13.2 ± 0.2
d	Cover Tape Thickness	0.1 max
	Max. Component Rotation or Tilt	10°
R	Min. Bending Radius	30

Carrier Tape Specifications (Option TSR2)

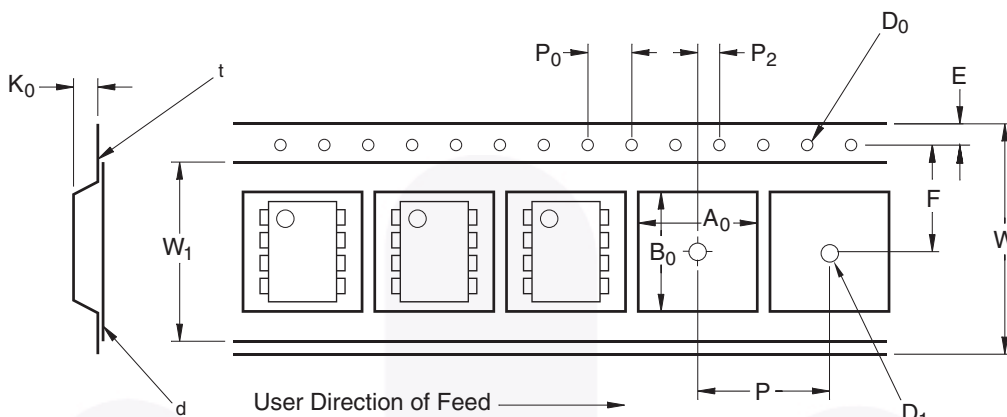

Symbol	Description	Dimension in mm
W	Tape Width	24.0 ± 0.3
t	Tape Thickness	0.40 ± 0.1
P ₀	Sprocket Hole Pitch	4.0 ± 0.1
D ₀	Sprocket Hole Diameter	1.55 ± 0.05
E	Sprocket Hole Location	1.75 ± 0.10
F	Pocket Location	11.5 ± 0.1
P ₂		2.0 ± 0.1
P	Pocket Pitch	16.0 ± 0.1
A ₀	Pocket Dimensions	12.80 ± 0.1
B ₀		10.35 ± 0.1
K ₀		5.7 ± 0.1
W ₁	Cover Tape Width	21.0 ± 0.1
d	Cover Tape Thickness	0.1 max
	Max. Component Rotation or Tilt	10°
R	Min. Bending Radius	30

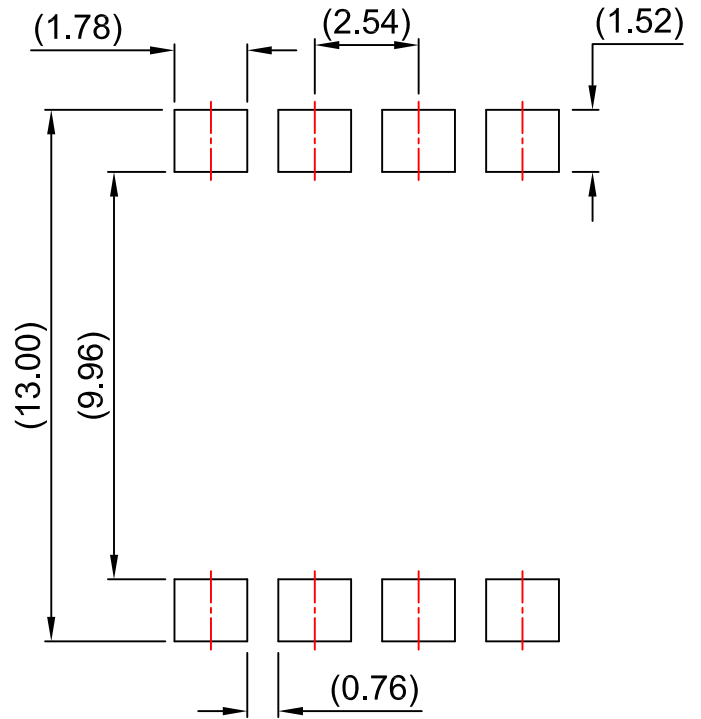
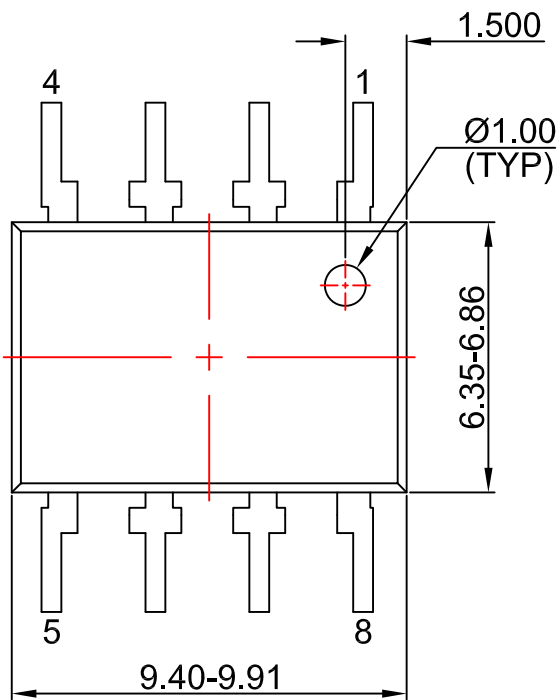

LAND PATTERN RECOMMENDATION

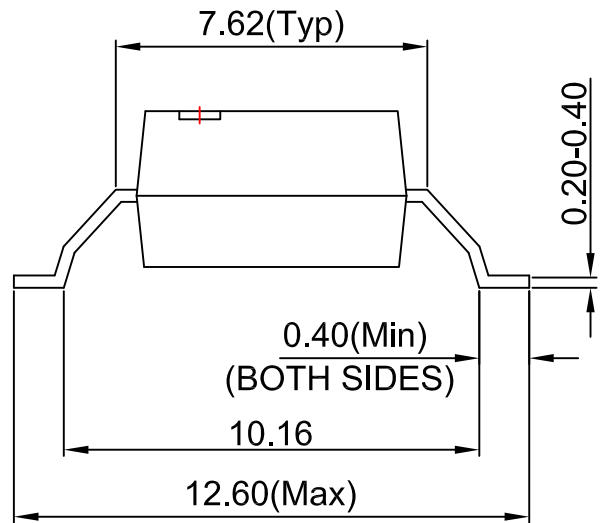
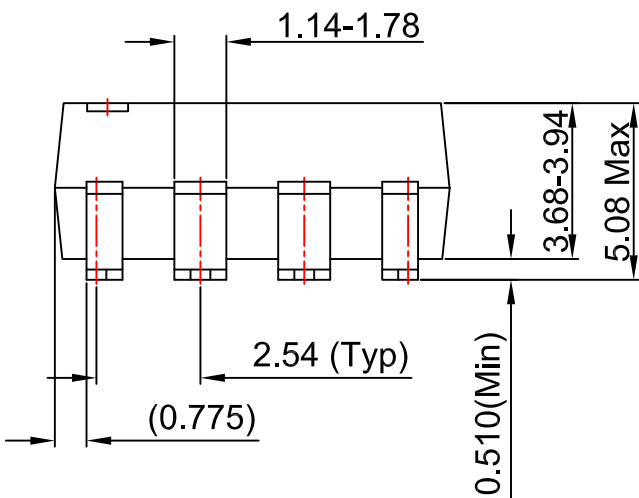

NOTES:

- A) NO STANDARD APPLIES TO THIS PACKAGE
- B) ALL DIMENSIONS ARE IN MILLIMETERS.
- C) DIMENSIONS ARE EXCLUSIVE OF BURRS, MOLD FLASH, AND TIE BAR EXTRUSION
- D) DWG FILENAME AND REVISION: MKT-N08Lrev2.



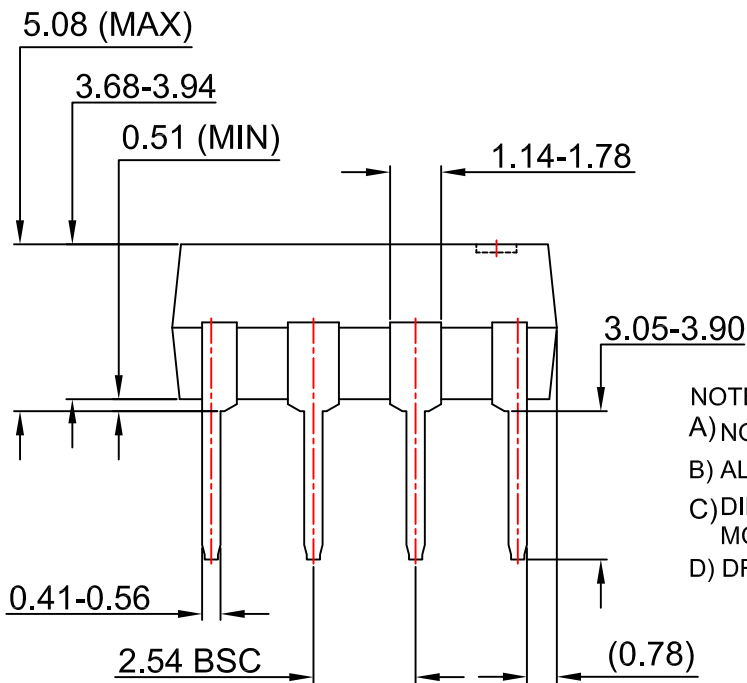
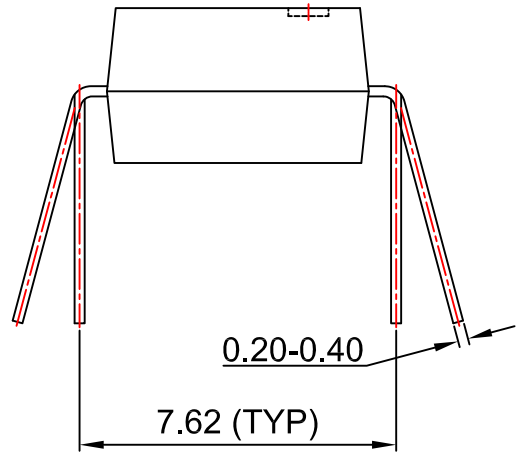
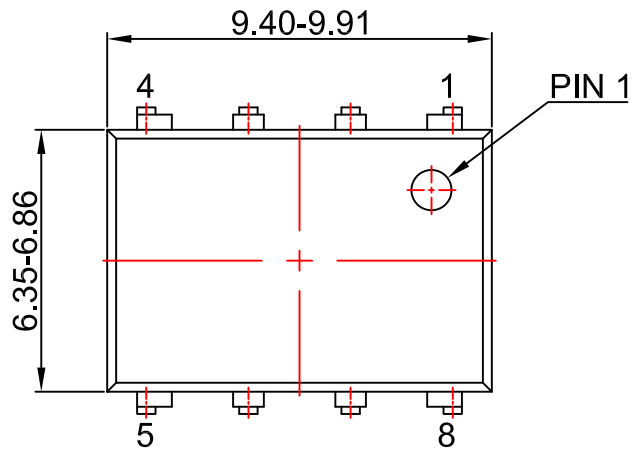

- NOTES:
 A) NO STANDARD APPLIES TO THIS PACKAGE
 B) ALL DIMENSIONS ARE IN MILLIMETERS.
 C) DIMENSIONS ARE EXCLUSIVE OF BURRS, MOLD FLASH, AND TIE BAR EXTRUSION
 D) DRAWING FILENAME AND REVISION: MKT-N08GREV7



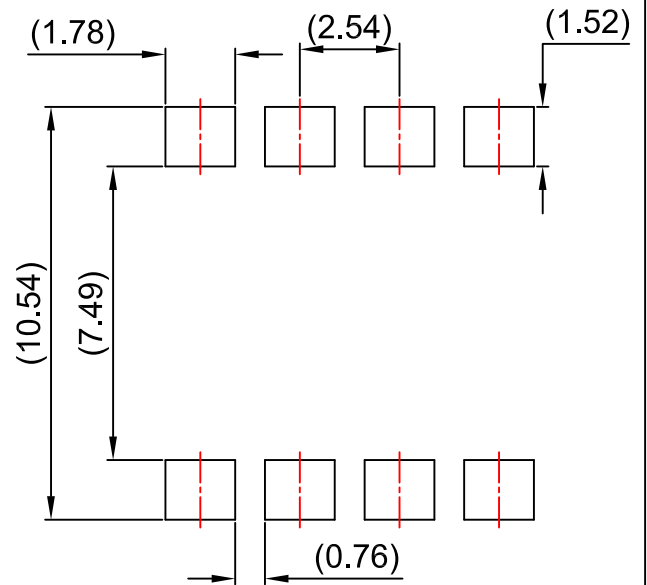
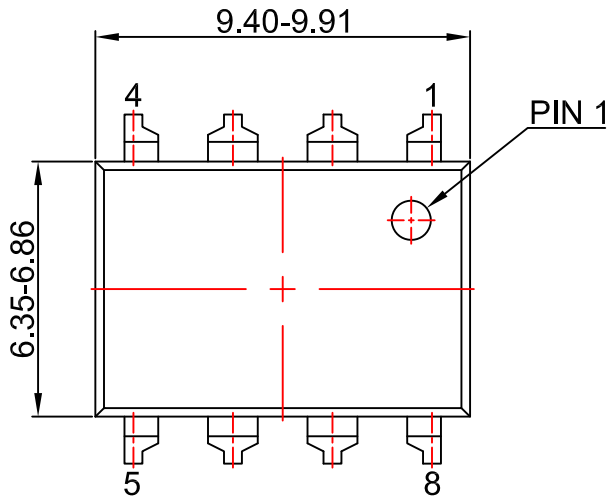

LAND PATTERN RECOMMENDATION

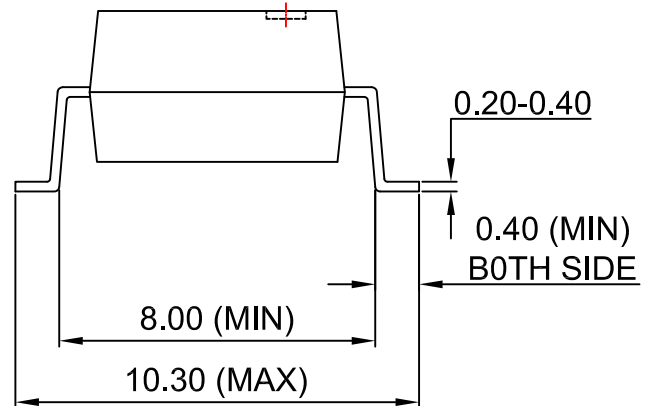
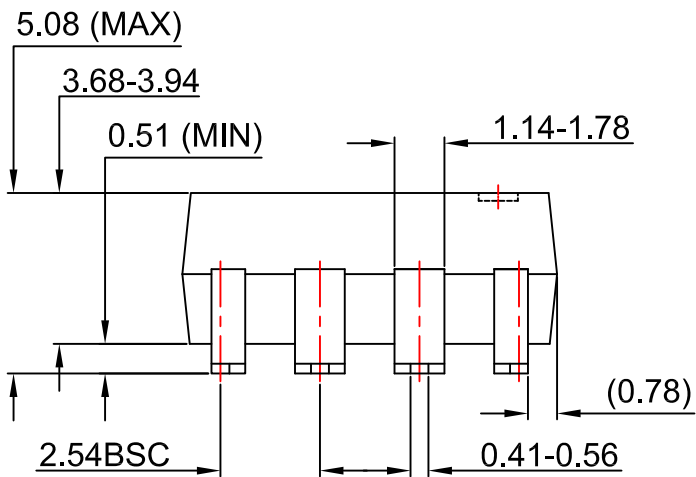

NOTES:

- A) NO STANDARD APPLIES TO THIS PACKAGE
- B) ALL DIMENSIONS ARE IN MILLIMETERS.
- C) DIMENSIONS ARE EXCLUSIVE OF BURRS, MOLD FLASH, AND TIE BAR EXTRUSION
- D) DRAWING FILENAME AND REVISION: MKT-N08Hrev7.



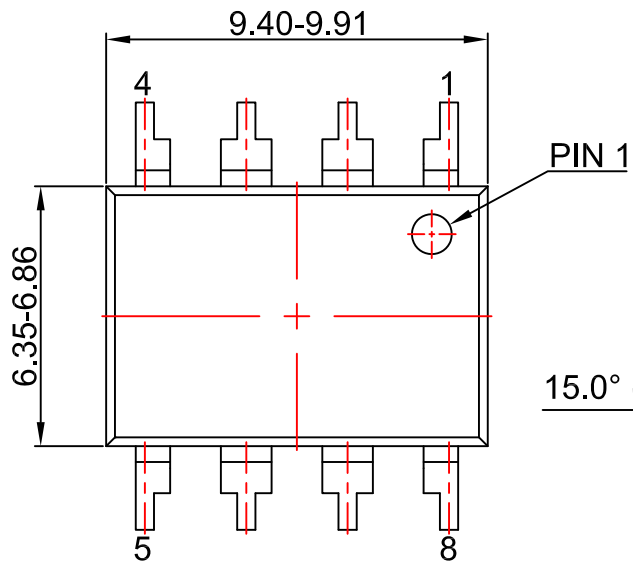

PIN 1

15.0° (MAX)

10.16 (TYP)

0.20-0.40

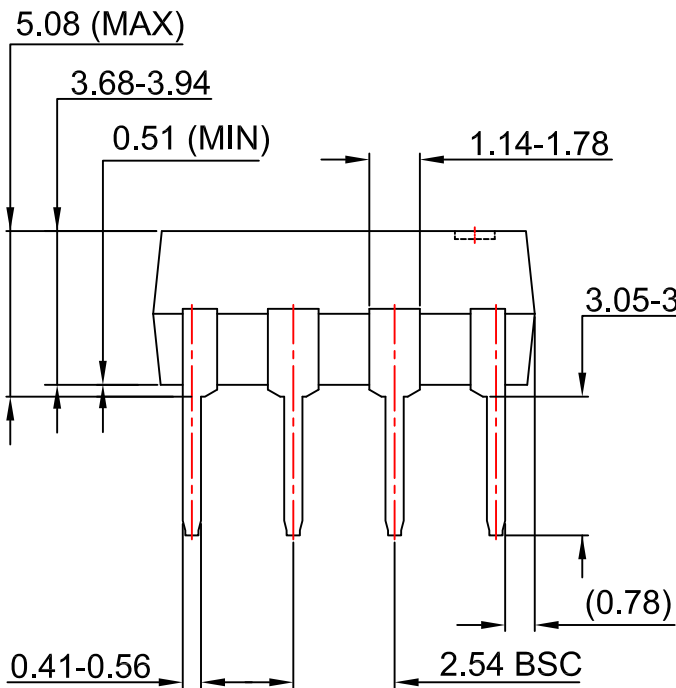

NOTES:

- A) NO STANDARD APPLIES TO THIS PACKAGE
- B) ALL DIMENSIONS ARE IN MILLIMETERS.
- C) DIMENSIONS ARE EXCLUSIVE OF BURRS, MOLD FLASH, AND TIE BAR EXTRUSION
- D) DRAWING FILENAME AND REVISION: MKT-N08REV7



ON Semiconductor and  are trademarks of Semiconductor Components Industries, LLC dba ON Semiconductor or its subsidiaries in the United States and/or other countries. ON Semiconductor owns the rights to a number of patents, trademarks, copyrights, trade secrets, and other intellectual property. A listing of ON Semiconductor's product/patent coverage may be accessed at www.onsemi.com/site/pdf/Patent-Marking.pdf. ON Semiconductor reserves the right to make changes without further notice to any products herein. ON Semiconductor makes no warranty, representation or guarantee regarding the suitability of its products for any particular purpose, nor does ON Semiconductor assume any liability arising out of the application or use of any product or circuit, and specifically disclaims any and all liability, including without limitation special, consequential or incidental damages. Buyer is responsible for its products and applications using ON Semiconductor products, including compliance with all laws, regulations and safety requirements or standards, regardless of any support or applications information provided by ON Semiconductor. "Typical" parameters which may be provided in ON Semiconductor data sheets and/or specifications can and do vary in different applications and actual performance may vary over time. All operating parameters, including "Typicals" must be validated for each customer application by customer's technical experts. ON Semiconductor does not convey any license under its patent rights nor the rights of others. ON Semiconductor products are not designed, intended, or authorized for use as a critical component in life support systems or any FDA Class 3 medical devices or medical devices with a same or similar classification in a foreign jurisdiction or any devices intended for implantation in the human body. Should Buyer purchase or use ON Semiconductor products for any such unintended or unauthorized application, Buyer shall indemnify and hold ON Semiconductor and its officers, employees, subsidiaries, affiliates, and distributors harmless against all claims, costs, damages, and expenses, and reasonable attorney fees arising out of, directly or indirectly, any claim of personal injury or death associated with such unintended or unauthorized use, even if such claim alleges that ON Semiconductor was negligent regarding the design or manufacture of the part. ON Semiconductor is an Equal Opportunity/Affirmative Action Employer. This literature is subject to all applicable copyright laws and is not for resale in any manner.

PUBLICATION ORDERING INFORMATION

LITERATURE FULFILLMENT:

Literature Distribution Center for ON Semiconductor
19521 E. 32nd Pkwy, Aurora, Colorado 80011 USA
Phone: 303-675-2175 or 800-344-3860 Toll Free USA/Canada
Fax: 303-675-2176 or 800-344-3867 Toll Free USA/Canada
Email: orderlit@onsemi.com

N. American Technical Support: 800-282-9855 Toll Free
USA/Canada
Europe, Middle East and Africa Technical Support:
Phone: 421 33 790 2910
Japan Customer Focus Center
Phone: 81-3-5817-1050

ON Semiconductor Website: www.onsemi.com
Order Literature: <http://www.onsemi.com/orderlit>
For additional information, please contact your local
Sales Representative

Mouser Electronics

Authorized Distributor

Click to View Pricing, Inventory, Delivery & Lifecycle Information:

[ON Semiconductor:](#)

[FOD3120](#) [FOD3120SDV](#) [FOD3120SV](#) [FOD3120TV](#) [FOD3120V](#) [FOD3120S](#) [FOD3120SD](#) [FOD3120TSR2V](#)
[FOD3120TSV](#)



Стандарт Электрон Связь

Мы молодая и активно развивающаяся компания в области поставок электронных компонентов. Мы поставляем электронные компоненты отечественного и импортного производства напрямую от производителей и с крупнейших складов мира.

Благодаря сотрудничеству с мировыми поставщиками мы осуществляем комплексные и плановые поставки широчайшего спектра электронных компонентов.

Собственная эффективная логистика и склад в обеспечивает надежную поставку продукции в точно указанные сроки по всей России.

Мы осуществляем техническую поддержку нашим клиентам и предпродажную проверку качества продукции. На все поставляемые продукты мы предоставляем гарантию .

Осуществляем поставки продукции под контролем ВП МО РФ на предприятия военно-промышленного комплекса России , а также работаем в рамках 275 ФЗ с открытием отдельных счетов в уполномоченном банке. Система менеджмента качества компании соответствует требованиям ГОСТ ISO 9001.

Минимальные сроки поставки, гибкие цены, неограниченный ассортимент и индивидуальный подход к клиентам являются основой для выстраивания долгосрочного и эффективного сотрудничества с предприятиями радиоэлектронной промышленности, предприятиями ВПК и научно-исследовательскими институтами России.

С нами вы становитесь еще успешнее!

Наши контакты:

Телефон: +7 812 627 14 35

Электронная почта: sales@st-electron.ru

Адрес: 198099, Санкт-Петербург,
Промышленная ул, дом № 19, литера Н,
помещение 100-Н Офис 331