



# MAX4206 Evaluation Kit

## General Description

The MAX4206 evaluation kit (EV kit) is a fully assembled and tested surface-mount circuit board that demonstrates the MAX4206 logarithmic amplifier. The MAX4206 computes the log ratio of an input current relative to a reference current and provides a corresponding voltage output with a default 0.25V/decade scale factor. The EV kit operates from a single +2.7V to +11V supply or from dual  $\pm 2.7V$  to  $\pm 5.5V$  supplies, with the ability to select one of four reference currents.

The MAX4206 EV kit can be used to evaluate the MAX4207 by changing the IC and the input RC networks R1, R2, C7, and C8.

## Features

- ◆ +2.7V to +11V Single-Supply Operation or  $\pm 2.7V$  to  $\pm 5.5V$  Dual-Supply Operation
- ◆ Selectable 10nA/100nA/1 $\mu$ A/10 $\mu$ A On-Board Reference Current
- ◆ Adjustable Output Scale Factor
- ◆ Surface-Mount Construction
- ◆ Fully Assembled and Tested

## Ordering Information

PART	TEMP RANGE	PIN PACKAGE
MAX4206EVKIT	0°C to +70°C	16 Thin QFN-EP* (4mm x 4mm)

\*EP = Exposed paddle.

**Note:** To evaluate the MAX4207, order a MAX4207ETE free sample with the MAX4206EVKIT.

## Component List

DESIGNATION	QTY	DESCRIPTION
C1	1	10 $\mu$ F $\pm 20\%$ , 16V X5R ceramic capacitor (1206) TDK C3216X5R1C106M
C2	1	10 $\mu$ F $\pm 20\%$ , 6.3V X5R ceramic capacitor (0805) Taiyo Yuden JMK212BJ106MG or TDK C2012X5R0J106M
C3–C6	4	0.1 $\mu$ F $\pm 10\%$ , 25V X7R ceramic capacitors (0603) TDK C1608X7R1E104K
C7, C8	2	100pF $\pm 5\%$ , 50V C0G ceramic capacitors (0603) Murata GRM1885C1H101J or TDK C1608C0G1H101J
D1, D2	0	Not installed, photodiode (TO-46)
R1, R2	2	100 $\Omega$ $\pm 1\%$ resistors (0603)
R3	0	Not installed, resistor (0603)
R4	0	Not installed, potentiometer
R5	1	30.1k $\Omega$ $\pm 0.1\%$ , precision chip resistor (0603) ICR PCF-W0603R-03-3012-B or Vishay P0603K3012BB

DESIGNATION	QTY	DESCRIPTION
R6–R9	4	10k $\Omega$ $\pm 0.1\%$ , precision chip resistors (0603) IRC PCF-W0603R-03-1002-B or Vishay P0603K1002BB
R10	1	4.99M $\Omega$ $\pm 0.5\%$ , precision chip resistor (0805) IRC CR0805F4M99D or Vishay D11P10049940.5PN
R11	1	499k $\Omega$ $\pm 0.5\%$ , precision chip resistor (0805) IRC PCF-W0805R-03-4993-D or Vishay D11P10049930.5PN
R12	1	49.9k $\Omega$ $\pm 0.5\%$ , precision chip resistor (0603) IRC PCF-W0603R-01-4992-D or Vishay D11P10049920.5PN
R13	1	4.99k $\Omega$ $\pm 0.5\%$ , precision chip resistor (0603) IRC PCF-W0603R-02-4991-D or Vishay D11P10049910.5PN
R14	0	Not installed, shorted by PC trace (0603)

Evaluates: MAX4206/MAX4207

# MAX4206 Evaluation Kit

## Component List (continued)

DESIGNATION	QTY	DESCRIPTION
U1	1	MAX4206ETE (16-pin TQFN 4mm x 4mm)
J1, J2	0	Not installed, edge-mount SMA connectors
JU1, JU6, JU9, JU10, JU11	5	2-pin headers

DESIGNATION	QTY	DESCRIPTION
JU2, JU5, JU7, JU8	4	3-pin headers
JU3	1	5-pin header
JU4	1	4-pin header
None	11	Shunts
None	1	MAX4206/7 PC board

## Component Suppliers

SUPPLIER	PHONE	FAX	WEBSITE
IRC	361-992-7900	361-992-3377	www.irctt.com
Murata	770-436-1300	770-436-3030	www.murata.com
Taiyo Yuden	800-348-2496	847-925-0899	www.t-yuden.com
TDK	847-803-6100	847-390-4405	www.component.tdk.com
Vishay	402-564-3131	402-563-6296	www.vishay.com

**Note:** Indicate that you are using the MAX4206/MAX4207 when contacting these suppliers.

### Quick Start

The MAX4206 EV kit is a fully assembled and tested surface-mount board. Follow the steps below for board operation. **Do not turn on the power supply until all connections are complete.**

#### Recommended Equipment

- Current source capable of sourcing 10nA to 1mA current
- Single +2.7V to +11V, 20mA DC power supply

#### Evaluating the MAX4206 with Single Supply

- 1) Verify that shunts are connected across jumpers JU1 and JU11 (single-supply operation, sets  $CMVIN = CMVOUT$ ).
- 2) Verify that shunts are connected across jumpers JU4 (pins 1 and 4), JU5 (pins 2 and 3), JU6, and JU7 (pins 1 and 2) (sets output scale factor  $K = 1V/decade$ ).
- 3) Verify that shunts are connected across jumpers JU8 (pins 2 and 3) and JU3 (pins 1 and 3) (sets on-board reference current = 100nA).
- 4) Verify that there is no shunt across jumpers JU2, JU9, and JU10.
- 5) Connect a +5V power supply to the VCC pad. Connect the power-supply ground to the GND pad.

- 6) Connect a 100 $\mu$ A current source to the LOGIIN pad.
- 7) Turn on the power supply and verify the output voltages  $LOGV1 = 0.75V$  and  $LOGV2 = 3.00V$ .

**Note:** For dual-supply operation, JU1 should be open. Reset the VCC and VDD to within operation range.

### Detailed Description

#### Jumper Selection

Jumper JU3 controls the REFISSET pin of the MAX4206/MAX4207 device. See Table 1 for JU3 function.

**Table 1. JU3 Function**

JU3 SHUNT POSITION	REFERENCE CURRENT
Pins 1 and 2	10nA
Pins 1 and 3	100nA
Pins 1 and 4	1 $\mu$ A
Pins 1 and 5	10 $\mu$ A

**Note:** Make sure a shunt is across pins 2 and 3 of JU8 when using the on-board reference current source.

# MAX4206 Evaluation Kit

Evaluates: MAX4206/MAX4207

**Table 2. Setting Output Scale Factor for MAX4206 (Single-Supply Operation)**

SCALE FACTOR (V/decade)	JU2 SHUNT POSITION	JU4 SHUNT POSITION	JU5 SHUNT POSITION	JU6 SHUNT POSITION	JU7 SHUNT POSITION
0.25	Not installed	Pins 1 and 2	Pins 2 and 3	Installed	Pins 1 and 2
0.50	Not installed	Pins 1 and 3	Pins 2 and 3	Installed	Pins 1 and 2
	Not installed	Pins 1 and 2	Pins 1 and 2	Installed	Pins 1 and 2
0.75	Not installed	Pins 1 and 3	Pins 1 and 2	Installed	Pins 1 and 2
1.00	Not installed	Pins 1 and 4	Pins 2 and 3	Installed	Pins 1 and 2
1.25	Not installed	Pins 1 and 4	Pins 1 and 2	Installed	Pins 1 and 2

**Table 3. Setting Output Scale Factor for MAX4206 (Dual-Supply Operation)/MAX4207**

SCALE FACTOR (V/decade)	JU2 SHUNT POSITION	JU4 SHUNT POSITION	JU5 SHUNT POSITION	JU6 SHUNT POSITION	JU7 SHUNT POSITION
0.25	Pins 2 and 3	Pins 1 and 3	Pins 2 and 3	Not Installed	Pins 2 and 3
	Pins 2 and 3	Pins 1 and 2	Pins 1 and 2	Not Installed	Pins 2 and 3
0.50	Pins 2 and 3	Pins 1 and 3	Pins 1 and 2	Not Installed	Pins 2 and 3
0.75	Pins 2 and 3	Pins 1 and 4	Pins 2 and 3	Not Installed	Pins 2 and 3
1.00	Pins 2 and 3	Pins 1 and 4	Pins 1 and 2	Not Installed	Pins 2 and 3

The EV kit incorporates jumpers JU2 and JU4–JU7 to set the output scale factor. See Tables 2 and 3 for setting the output scale factor for the MAX4206 and MAX4207.

Jumper JU8 controls the REFIIN pin of the MAX4206/MAX4207 device. See Table 4 for JU8 function.

The EV kit incorporates jumper JU11 to create a connection between CMVIN and CMVOUT pins. To set the common-mode voltage input to a voltage other than 0.5V (MAX4206) or 0V (MAX4207), remove the shunt across JU11, and then connect a desired common-mode voltage on the CMVIN pad.

### Output Offset (MAX4206)

To adjust the output offset voltage for single-supply operation, cut open the short on R14, install a resistor on the R14 pads, and then apply a current on the OSADJ pad. The value of R14 can be calculated by the following equation:

$$R14 = V_{OS} / I_{OSADJ}$$

where  $V_{OS}$  is the desired offset voltage, and  $I_{OSADJ}$  is a user-supplied offset current.

### Evaluating the MAX4207

To evaluate the MAX4207 with the MAX4206 EV kit, replace the MAX4206ETE with a MAX4207ETE, replace R1, R2, C7, and C8 with component values 330Ω, 330Ω, 33pF, and 33pF, respectively.

**Jumper JU1 must be open to ensure proper operation with dual supplies.**

**Table 4. JU8 Function**

JU8 SHUNT POSITION	REFIIN PIN
Pins 1 and 2	REFIIN is connected to the REFIIN pad, requiring an external reference source.
Pins 2 and 3	REFIIN is connected to the REFIOUT pad, using the internal reference current source.

# MAX4206 Evaluation Kit

## **Evaluating the MAX4207 (Dual-Supply Operation)**

- 1) Verify that there is no shunt across jumpers JU1, JU9, and JU10 (dual-supply operation).
- 2) Verify that there is a shunt across JU11 (sets  $CMVIN = CMVOUT$ ).
- 3) Verify that shunts are connected across jumpers JU2 (pins 2 and 3), JU4 (pins 1 and 4), JU5 (pins 1 and 2), and JU7 (pins 2 and 3); and JU6 is open (sets output scale factor  $K = 1V/decade$ ).
- 4) Verify that shunts are connected across jumpers JU8 (pins 2 and 3) and JU3 (pins 1 and 3) (sets on-board reference current = 100nA).
- 5) Connect a +5V power supply to the VCC pad. Connect the power-supply ground to the GND pad. Connect a -5V power supply to the VEE pad.
- 6) Connect a 100 $\mu$ A current source to the LOGIIN pad.
- 7) Turn on the power supply and verify the output voltages  $LOGV1 = -0.75V$  and  $LOGV2 = 3.00V$ .

## **Output Offset Adjustment (MAX4207)**

The MAX4207 accepts a large output-offset voltage adjustment at the inverting configuration. To adjust the output offset voltage, install a resistor on R3 and potentiometer on R4 pads, and make sure there is a shunt across JU2 (pins 1 and 2). The magnitude of the offset voltage is given by the following equation:

$$V_{OS} = REFOUT \times (R4 / (R3 + R4)) \times (1 + R_{COMB} / R6)$$

where  $V_{OS}$  is the desired offset voltage, and  $R_{COMB}$  is the effective resistance between the LOGV2 and SCALE pins.

# MAX4206 Evaluation Kit

Evaluates: MAX4206/MAX4207

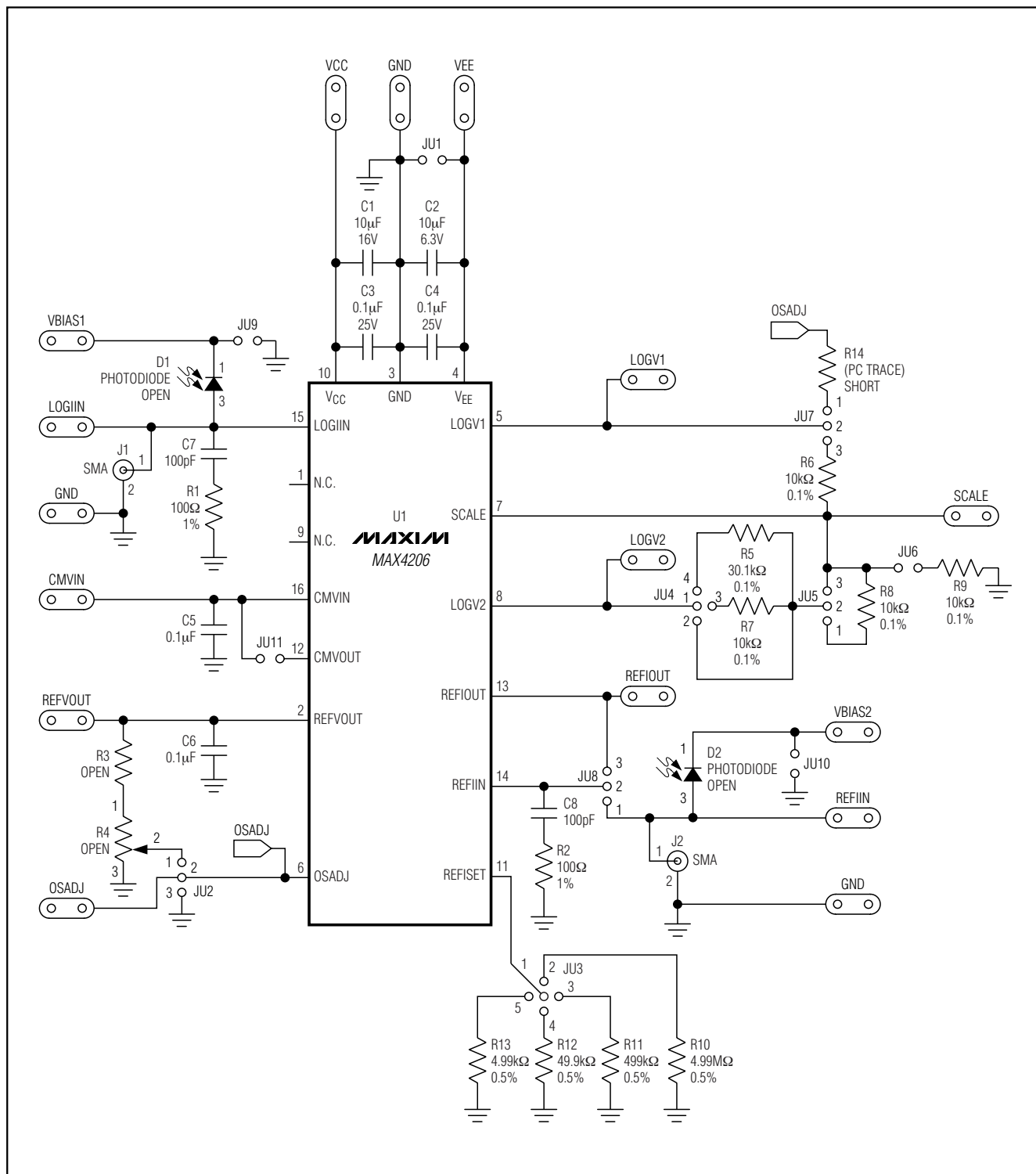

Figure 1. MAX4206 EV Kit Schematic

# MAX4206 Evaluation Kit

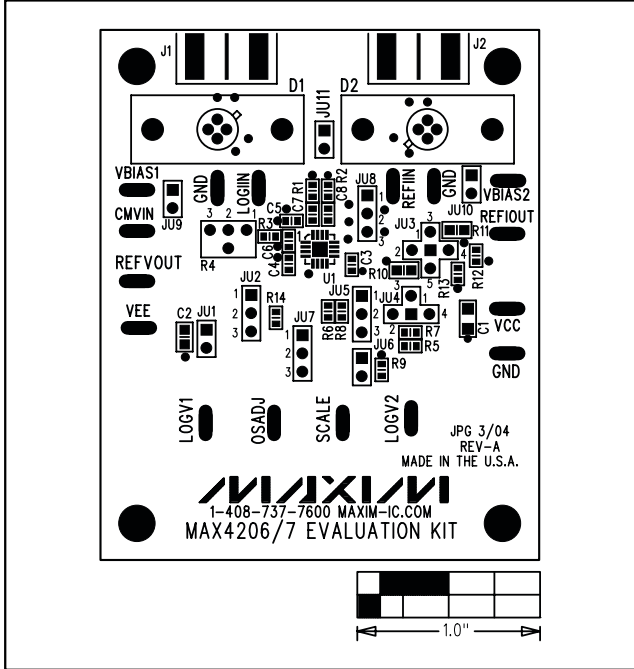

Figure 2. MAX4206 EV Kit Component Placement Guide—Component Side

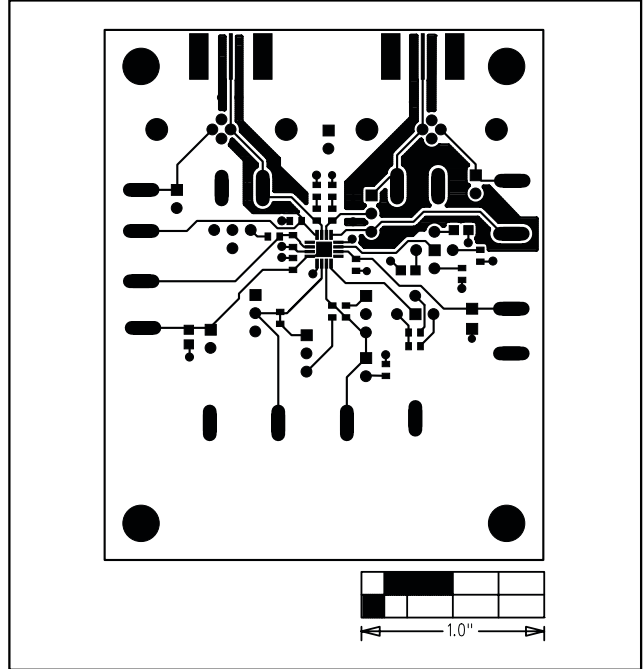

Figure 3. MAX4206 EV Kit PC Board Layout—Component Side

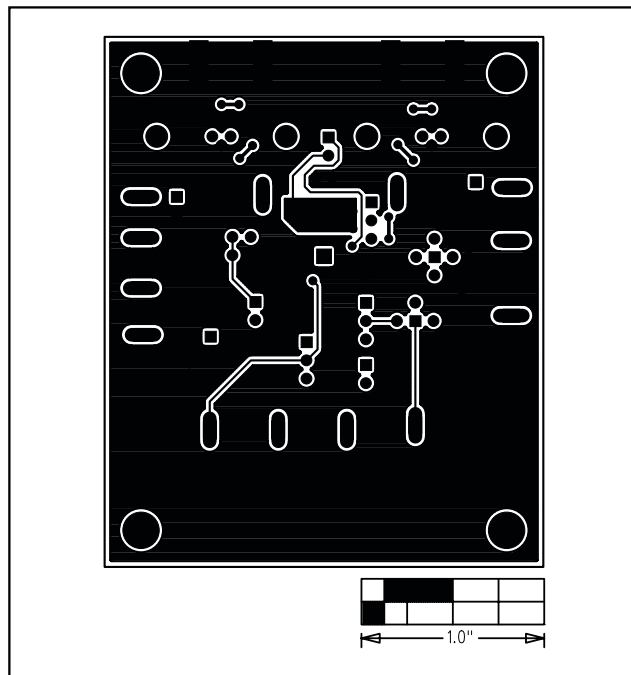

Figure 4. MAX4206 EV Kit PC Board Layout—Solder Side

Maxim cannot assume responsibility for use of any circuitry other than circuitry entirely embodied in a Maxim product. No circuit patent licenses are implied. Maxim reserves the right to change the circuitry and specifications without notice at any time.

6 Maxim Integrated Products, 120 San Gabriel Drive, Sunnyvale, CA 94086 408-737-7600



## Стандарт Электрон Связь

Мы молодая и активно развивающаяся компания в области поставок электронных компонентов. Мы поставляем электронные компоненты отечественного и импортного производства напрямую от производителей и с крупнейших складов мира.

Благодаря сотрудничеству с мировыми поставщиками мы осуществляем комплексные и плановые поставки широчайшего спектра электронных компонентов.

Собственная эффективная логистика и склад в обеспечивает надежную поставку продукции в точно указанные сроки по всей России.

Мы осуществляем техническую поддержку нашим клиентам и предпродажную проверку качества продукции. На все поставляемые продукты мы предоставляем гарантию .

Осуществляем поставки продукции под контролем ВП МО РФ на предприятия военно-промышленного комплекса России , а также работаем в рамках 275 ФЗ с открытием отдельных счетов в уполномоченном банке. Система менеджмента качества компании соответствует требованиям ГОСТ ISO 9001.

Минимальные сроки поставки, гибкие цены, неограниченный ассортимент и индивидуальный подход к клиентам являются основой для выстраивания долгосрочного и эффективного сотрудничества с предприятиями радиоэлектронной промышленности, предприятиями ВПК и научно-исследовательскими институтами России.

С нами вы становитесь еще успешнее!

### Наши контакты:

**Телефон:** +7 812 627 14 35

**Электронная почта:** [sales@st-electron.ru](mailto:sales@st-electron.ru)

**Адрес:** 198099, Санкт-Петербург,  
Промышленная ул, дом № 19, литера Н,  
помещение 100-Н Офис 331