



1. SCOPE

This specification is applied to the ceramics discriminator used with the type JT10.7MG18 for FM receiver. Please contact us before using any of the products in the applications not described above.

2. PART NO.:

PART NUMBER	CUSTOMER PART NO	SPECIFICATION NO
JT10.7MG18		

3. OUTLINE DRAWING AND DIMENSIONS:

Appearance: No visible damage and dirt.

Construction: Leads are soldered on electrode and body is molded by resin.

Dimensions:

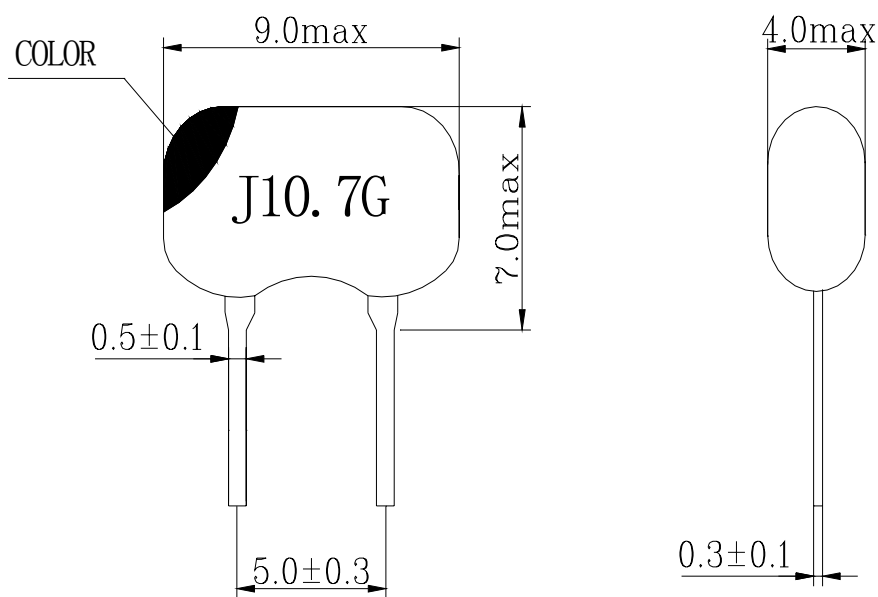

UNIT: mm

#### 4. ELECTRICAL SPECIFICATIONS:

No	Item	Requirements
4.1	Center Frequency $f_0$ (MHz)	A: $10.700 \pm 0.030$ (RED)
4.2	Recovered Audio Voltage (at $f_0$ ) (mV) min	60
4.3	Distortion (at $f_0$ ) (%) max	0.9
4.4	Recovered Audio 3dB Bandwidth (kHz) min	300
4.5	Temp. Coefficient of Frequency (ppm/°C) max	$\pm 100$ (Center Frequency drift, $-10^\circ\text{C} \sim +70^\circ\text{C}$ )
4.6	Insulation Resistance $R_i$ (M $\Omega$ ) min	100 (100V, 1min)
4.7	Withstanding Voltage	50VDC, 1min

#### 5. MEASUREMENT:

Measurement Conditions: Parts shall be measured under a condition (Temp.:  $20 \pm 15^\circ\text{C}$ , Humidity :  $65 \pm 20\%$  R.H.) unless the standard condition (Temp.:  $25 \pm 2^\circ\text{C}$ , Humidity :  $65 \pm 5\%$  R.H.) is regulated to measure.

Test Circuit:

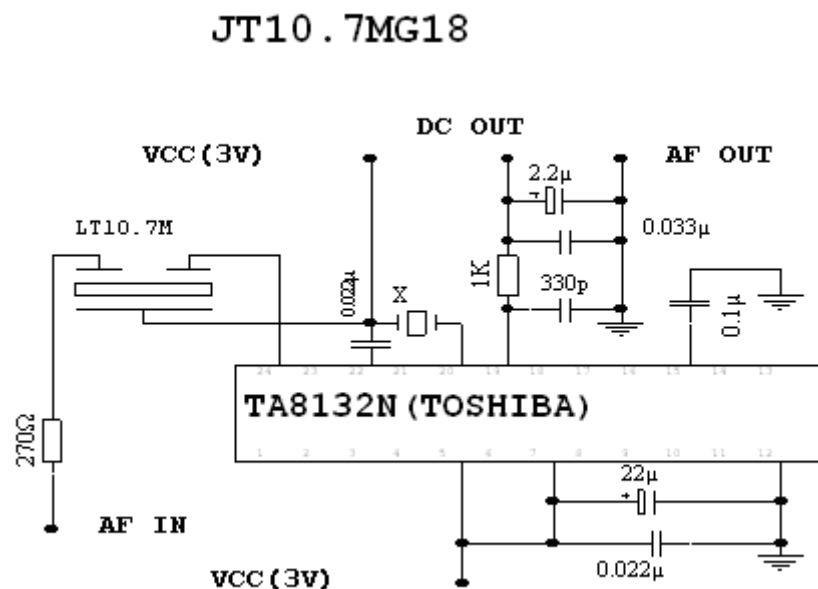



Input Signal:

Input Level: 80dB  $\mu$  V

Modulation Frequency: 1000Hz

Frequency Deviation:  $\pm 22.5$ kHz

Center Frequency (fo) : Center frequency is measured under the condition that modulated and 80dB  $\mu$  V input signal (center) is supplied and varied its frequency. It is defined as the frequency at that D.C.output voltage shall correspond to that for 0dB  $\mu$  V input signal.

Recovered Audio Voltage: It is defined as the recovered audio voltage at center frequency (fo) .

Distortion: It is defined as the distortion at center frequency (fo) .

Recovered Audio 3dB Bandwidth: It is defined as the difference between the two frequencies where the recovered audio voltage 3dB from the level of center frequency (fo) .

## 6. PHYSICAL AND ENVIRONMENTAL CHARACTERISTICS

No	Item	Condition of Test	Performance Requirements
6.1	Humidity	Subject the discriminator at $+40 \pm 2^\circ\text{C}$ and 90%-95% R.H. for 100 hours, discriminator shall be measured after being placed in natural conditions for 1 hour.	It shall fulfill the specifications in Table 1.
6.2	High Temperature Exposure	Subject the discriminator to $+85 \pm 5^\circ\text{C}$ for 100 hours, discriminator shall be measured after being placed in natural conditions for 1 hour.	It shall fulfill the specifications in Table 1.
6.3	Low Temperature Exposure	Subject the discriminator to $-25 \pm 5^\circ\text{C}$ for 100 hours, discriminator shall be measured after being placed in natural conditions for 1 hour.	It shall fulfill the specifications in Table 1.
6.4	Temperature Cycling	Subject the discriminator to $-25^\circ\text{C}$ for 30 min. followed by a high temperature of $+85^\circ\text{C}$ for 30 min. Cycling shall be repeated 5 times. Discriminator shall be measured after being placed in natural conditions for 1 hour.	It shall fulfill the specifications in Table 1.



6. PHYSICAL AND ENVIRONMENTAL CHARACTERISTICS

(Continued from the preceding page)

No	Item	Condition of Test	Performance Requirements
6.5	Vibration	Subject the discriminator to vibration for 2 hours each in x y and z axis with the amplitude of 1.5mm, the frequency shall be varied uniformly between the limits of 10Hz-55Hz and then discriminator shall be measured.	It shall fulfill the specifications in Table 1.
6.6	Mechanical Shock	Discriminator shall be measured after 3 times' random dropping from the height of 100cm on concrete floor.	No visible damage and it shall fulfill the specifications in Table 1.
6.7	Resistance to Soldering Heat	Lead terminals are immersed up to 2 mm from discriminator's body in soldering bath of $260 \pm 5 \text{ }^\circ\text{C}$ for $5 \pm 1$ seconds and then discriminator shall be measured after being placed in natural conditions for 1 hour	It shall fulfill the specifications in Table 1.
6.8	Solderability	Lead terminals are immersed up to 2mm from discriminator's body in soldering bath of $250 \pm 5^\circ\text{C}$ for $2 \pm 0.5$ sec.	More than 95% of the terminal surface of the discriminator shall be covered with fresh solder.
6.9	Terminal Strength	Force of 5N is applied to each lead in axial direction for $10 \pm 1$ sec.	No visible damage and it shall fulfill the specifications in Table 1.
6.9.1	Terminal Pulling	When force of 5N is applied to each lead in axial direction, the lead shall folded up $90^\circ$	
6.9.2	Terminal Bending	from the axial direction and folded back to the axial direction. The speed of folding shall be each 3 seconds.	

Table 1

Item	Specification after test
Center Frequency drift	$\pm 30\text{kHz}$ max
Recovered Audio Voltage drift	$\pm 2\text{dB}$ max

Note : The limits in the above table are referenced to the initial measurements.

**SHENZHEN LUGUANG ELECTRONIC TECHNOLOGY CO.,LTD.**

7. REVIEW OF SPECIFICATIONS

When something gets doubtful with this specifications, we shall jointly work to get an agreement.

8. PACKAGE

To protect the products in storage and transportation, it is necessary to pack them (outer and inner package). On paper pack, the following requirements are requested.

a) Dimensions and Mark

At the end of package, the warning (moisture proof, upward put) should be stick to it.

Dimensions and Mark (see below)

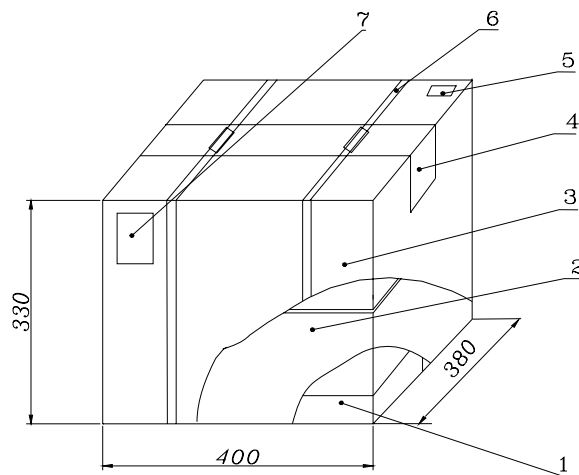

NO.	Name	Quantity	Notes
1	Inner Box	40	
2	Box	2	
3	Package	1	
4	Adhesive tape	1.2m	
5	Label	1	
6	Belt	2.9m	
7	Certificate of approval	1	

b) Section of package

Package is made of corrugated paper with thickness of 0.8cm. Package has 2 inner boxes, each has 20 inner boxes (each box for plastic bag).

c) Quantity of package

Per plastic bag 500 pieces

Per inner box 3 plastic bag

Per package 40 inner boxes ( 60000 pieces of piezoelectric ceramic part )

d) Inner box Dimensions

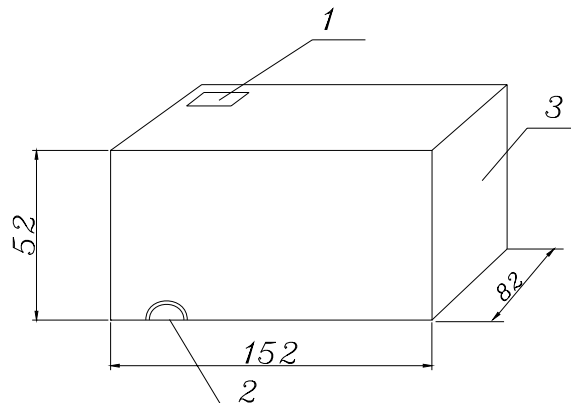

1	Label
2	QC Label
3	Inner Box

1.UNIT: mm

Pars shall be packaged in box with hold down tape upside. Part No., quantity and lot No.



## Стандарт Электрон Связь

Мы молодая и активно развивающаяся компания в области поставок электронных компонентов. Мы поставляем электронные компоненты отечественного и импортного производства напрямую от производителей и с крупнейших складов мира.

Благодаря сотрудничеству с мировыми поставщиками мы осуществляем комплексные и плановые поставки широчайшего спектра электронных компонентов.

Собственная эффективная логистика и склад в обеспечивает надежную поставку продукции в точно указанные сроки по всей России.

Мы осуществляем техническую поддержку нашим клиентам и предпродажную проверку качества продукции. На все поставляемые продукты мы предоставляем гарантию .

Осуществляем поставки продукции под контролем ВП МО РФ на предприятия военно-промышленного комплекса России , а также работаем в рамках 275 ФЗ с открытием отдельных счетов в уполномоченном банке. Система менеджмента качества компании соответствует требованиям ГОСТ ISO 9001.

Минимальные сроки поставки, гибкие цены, неограниченный ассортимент и индивидуальный подход к клиентам являются основой для выстраивания долгосрочного и эффективного сотрудничества с предприятиями радиоэлектронной промышленности, предприятиями ВПК и научно-исследовательскими институтами России.

С нами вы становитесь еще успешнее!

### Наши контакты:

**Телефон:** +7 812 627 14 35

**Электронная почта:** [sales@st-electron.ru](mailto:sales@st-electron.ru)

**Адрес:** 198099, Санкт-Петербург,  
Промышленная ул, дом № 19, литера Н,  
помещение 100-Н Офис 331