

MAX1493X Evaluation Kit

Evaluates: MAX14930, MAX14931, MAX14932,
MAX14934, MAX14935, MAX14936

General Description

The MAX1493X evaluation kit (EV kit) demonstrates the functionality of the MAX1493X 4-channel, unidirectional, digital isolators in a 16-pin, SOIC surface-mount package. The EV kit features two independent isolated power supplies independently adjustable to +5V.

Ordering Information appears at end of data sheet.

Features

- Ease of Use
 - Easy Powering Through Micro-USB or Test Points
 - SMA Connectors to Connect to External Equipment
- Guaranteed Up to 5kV_{RMS} Isolation (for the Wide-Body SOIC Version)
 - Also Evaluates the 2.75kV_{RMS} Versions.

MAX1493X Wide-Body Evaluation Kit Board Photo

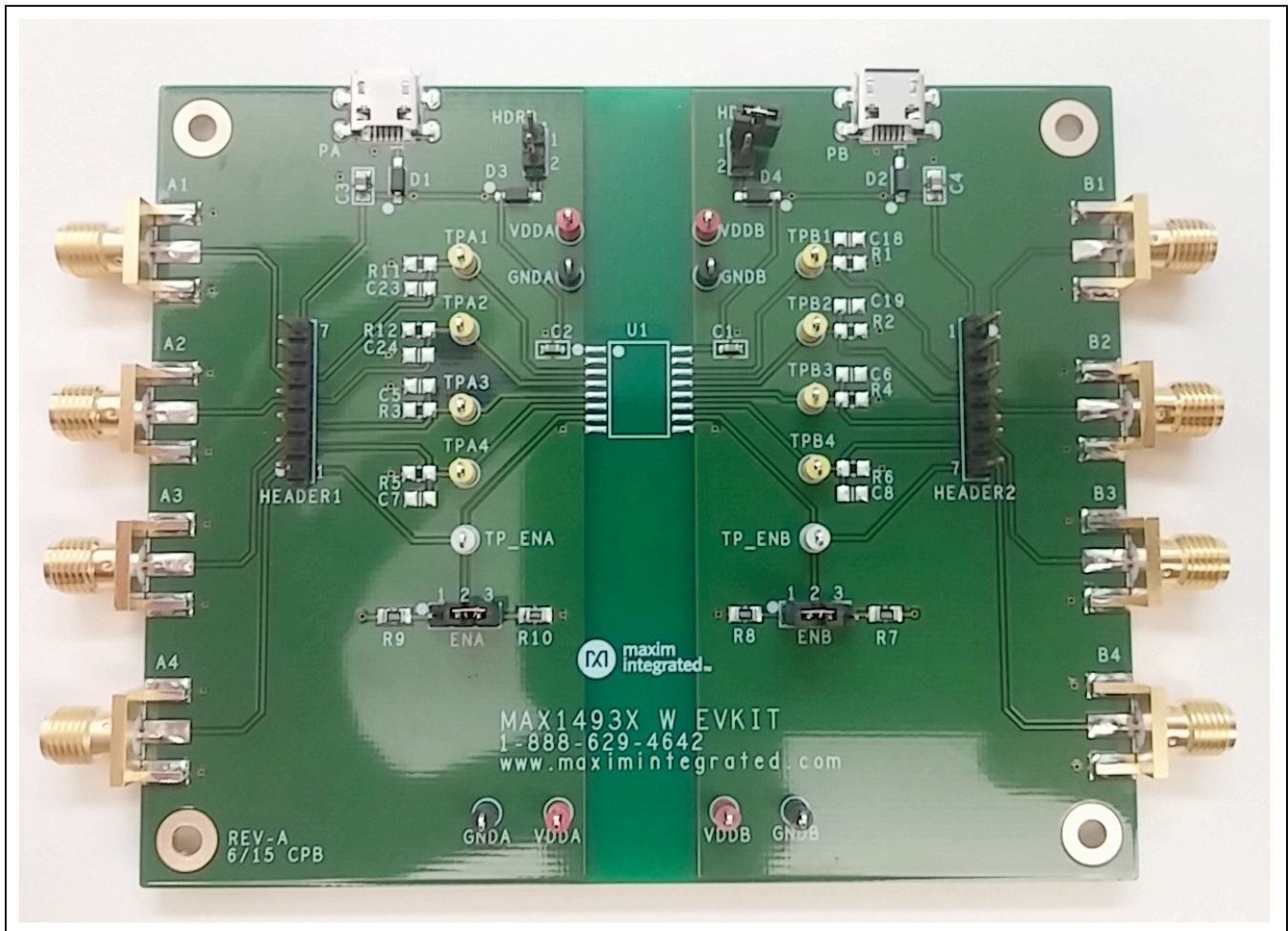

Quick Start

Required Equipment

- MAX1493X EV kit
- MAX1493X device separated sampled
- Two 5V DC power supplies or USB cables with a micro-B connector
- Signal/function generator
- Oscilloscope

Procedure

The MAX1493X EV kit has everything except the DUT installed. The user can install the desired flavor of the MAX1493X family of unidirectional isolators. Once installed, follow the steps below to verify board operation:

- 1) Connect the DC power supplies between the MAX1493X EV kit's VDDA/VDDB and GNDA/GNDB test points.
- 2) Turn on the DC power supplies and set to 5V, then enable the power-supply output.

Note: It is also possible to power the MAX1493X EV kit with standard USB ports. To do so, connect the micro-B-end of the USB cables into PA/PB on the board. Connect the A-end of the USB cable into the USB ports. Please ensure that only one type of supply is used on either side (USB or DC power supply).

- 3) Connect any signal to the SMA connectors or test points and observe the isolated signal on the other side using an oscilloscope.

Detailed Description of Hardware (or Software)

The MAX1493X EV kit is powered from two +5V supplies, as described below.

External Power Supplies

Power on the MAX1493X EV kit is derived from two +5V sources. Connect external supplies to the +5V and GNDA test points, or connect a micro-B USB cable to the on-board PA/PB connectors to provide the 5V. Both options have a reverse-current protection diode.

The MAX1493X level-shifts the data and control signals, transmitting them across the isolation barrier. Each supply is set independently and can be present over the entire specified range of the device, regardless of the level or presence of the other supply.

Figure 1 is a simplified schematic showing the connections for evaluating the MAX1493X in a simple microprocessor interface. The MAX1493X level-shifts the signals and transmits them across the isolation barrier.

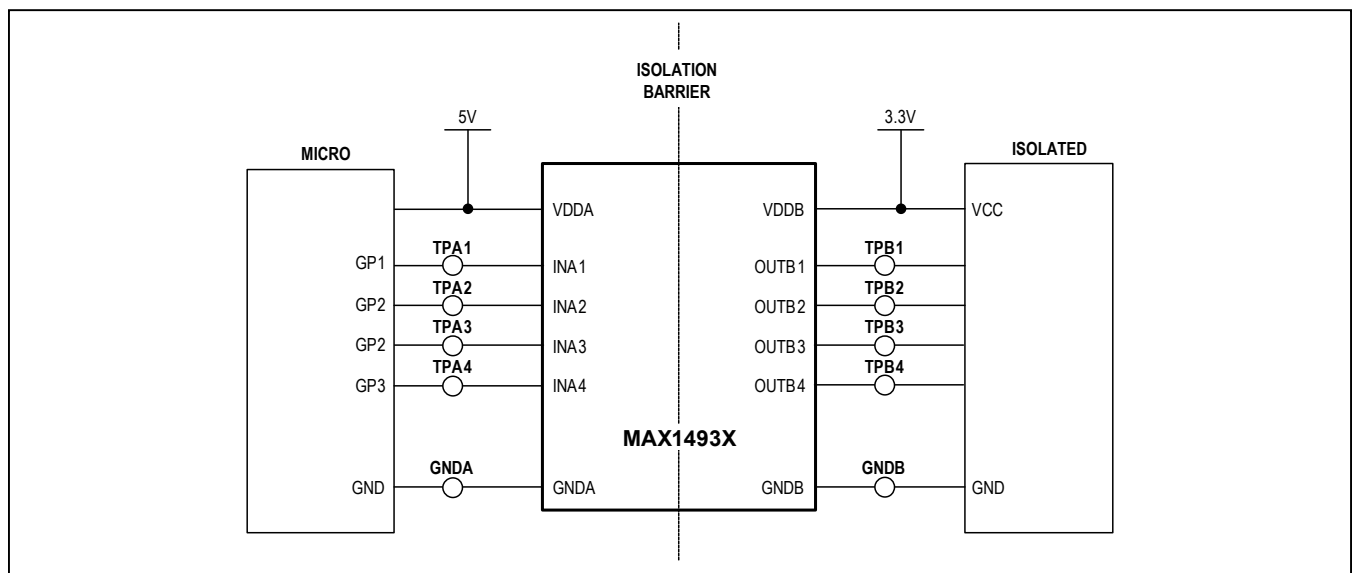

Figure 1. Simplified Schematic Shown for MAX1493X

MAX1493X Evaluation Kit

Evaluates: MAX14930, MAX14931, MAX14932, MAX14934, MAX14935, MAX14936

Termination

Each input and output has an unpopulated resistor and capacitor to GND_ to allow terminating based on customer requirements.

Jumpers

Two jumpers (ENA/ENB) are provided to enable either side of the isolation barrier. These are active-high signals. To enable each side, connect to VDDA/VDDB, respectively.

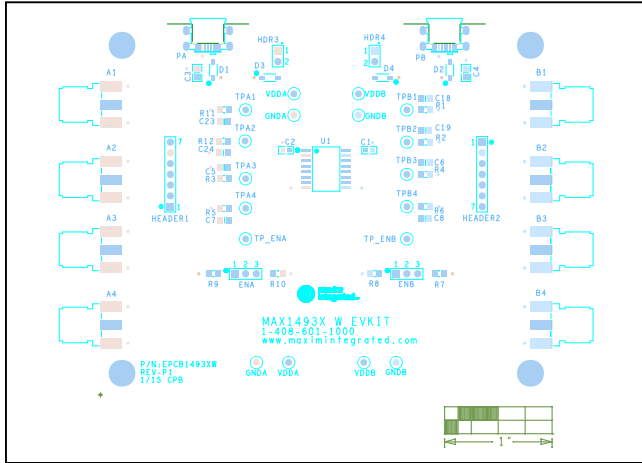

Figure 2. MAX1493X EV Kit Component Placement Guide (Top Silkscreen)

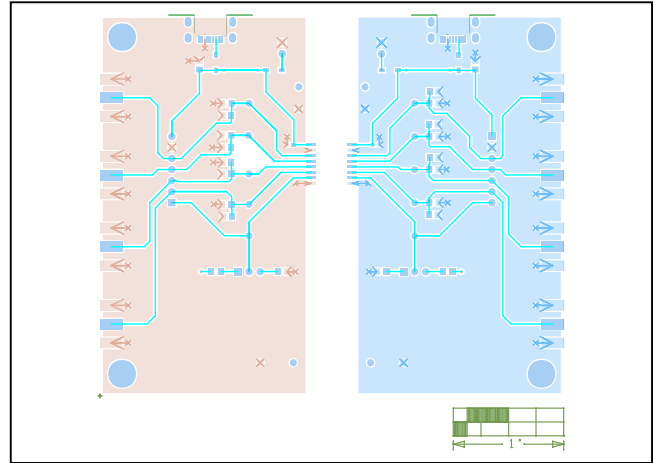

Figure 3. MAX1493X EV Kit PCB Layout (Top Layer)

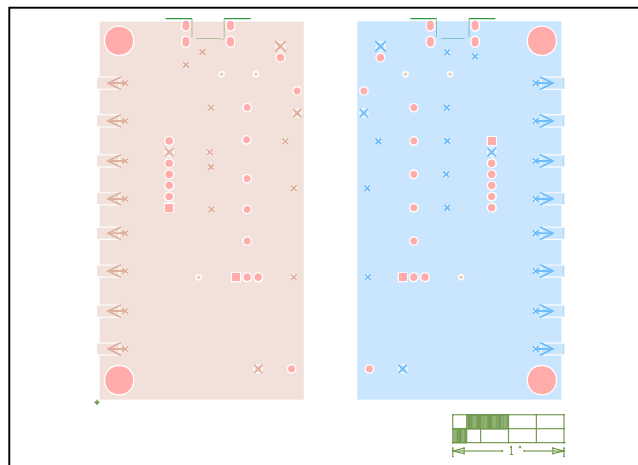

Figure 4. MAX1493X EV Kit PCB Layout (Bottom Layer)

MAX1493X Evaluation Kit

Evaluates: MAX14930, MAX14931, MAX14932,
MAX14934, MAX14935, MAX14936

Component List and Schematic

See the following links for component information and schematic:

- [MAX1493X EV BOM](#)
- [MAX1493X EV Schematic](#)

Ordering Information

PART	TYPE
MAX1493XWEVKIT#	EVKIT (for wide-body SOIC packages)
MAX1493XSEVKIT#	EVKIT (for narrow-body SOIC packages)

#Denotes RoHS compliant.

MAX1493X Evaluation Kit

Evaluates: MAX14930, MAX14931, MAX14932,
MAX14934, MAX14935, MAX14936

Revision History

REVISION NUMBER	REVISION DATE	DESCRIPTION	PAGES CHANGED
0	6/15	Initial release	—
1	8/15	Expanded part numbers that this document applies to	1, 2, 4

For pricing, delivery, and ordering information, please contact Maxim Direct at 1-888-629-4642, or visit Maxim Integrated's website at www.maximintegrated.com.

Maxim Integrated cannot assume responsibility for use of any circuitry other than circuitry entirely embodied in a Maxim Integrated product. No circuit patent licenses are implied. Maxim Integrated reserves the right to change the circuitry and specifications without notice at any time.

8 7 6 5 4 3 2 1

D

D

C

C

B

B

A

A

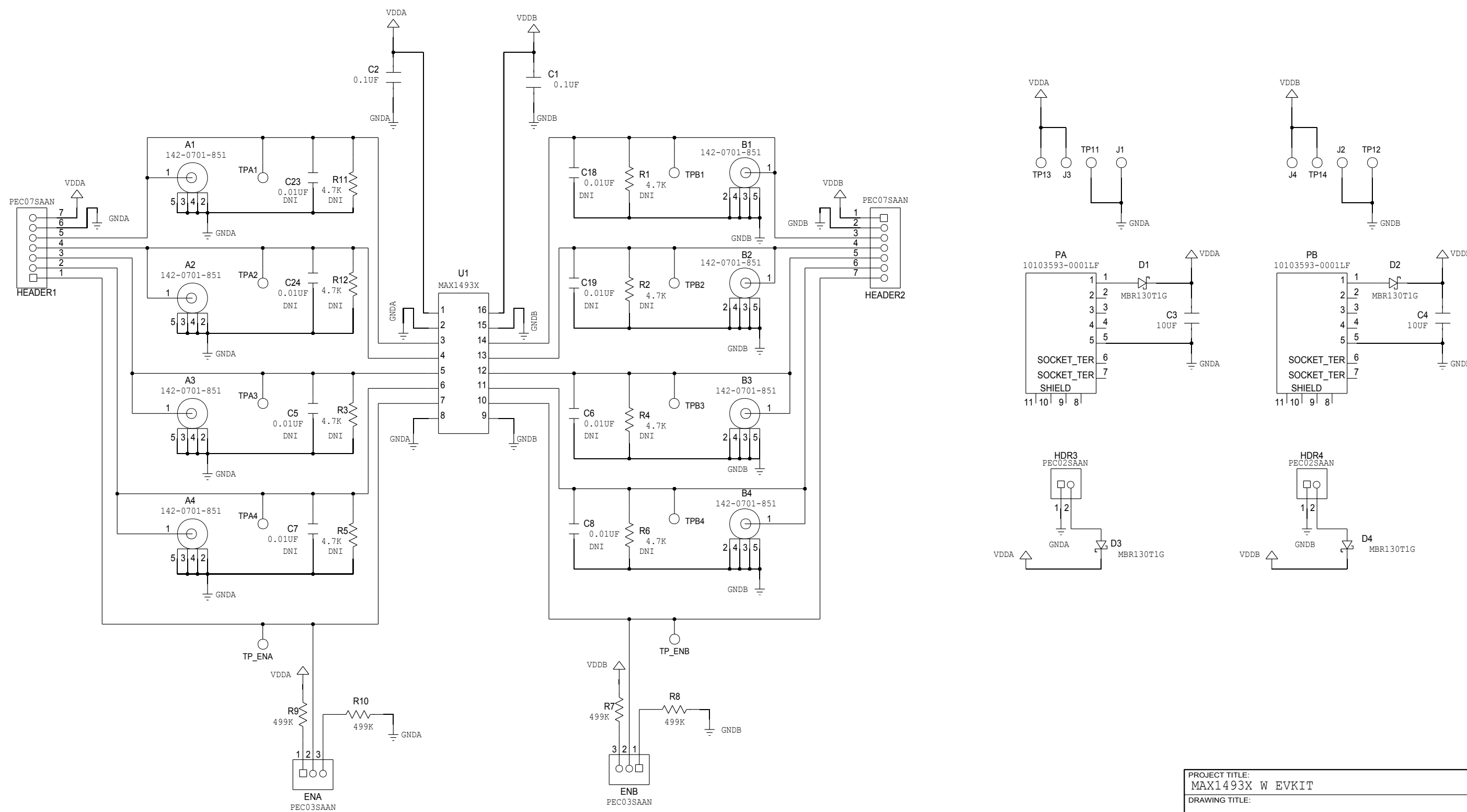

PROJECT TITLE: MAX1493X W EVKIT		
DRAWING TITLE:		
SIZE B	HARDWARE NUMBER: EPCB1493XW	DATE: 01/28/15
ENGINEER:	DRAWN BY:	REV: P1
	TEMPLATE REV: 1.5	SHEET 2 OF 2

8 7 6 5 4 3 2 1

BILL OF MATERIALS (BOM)

ITEM	QTY	REF DES	MFG PART #	MOUSER PART NUMBERS	VALUE	COMMENTS
1	8	A1-A4,B1-B4	142-0701-851	530-142-0701-801	142-0701-851	
2	2	C1,C2	EMK107BJ104KAH	963-EMK107BJ104KAHT	0.1UF	
3	2	C3,C4	LMK212F106ZG-T	963-LMK212F106ZG-T	10UF	
4	4	D1-D4	MBR130T1G	863-MBR130T3G	MBR130T1G	
5	2	ENA,ENB	961103-6404-AR	517-9611036404AR	PEC03SAAN	
6	2	HDR3,HDR4	961102-6404-AR	517-9611026404AR	PEC02SAAN	
7	2	HEADER1,HEADER2	961107-6404-AR	517-9611076404AR	PEC07SAAN	
8	4	GNDA, GNDB	5001	534-5001	N/A	
9	4	VDDA, VDDB	5000	534-5000	N/A	
10	2	PA,PB	10103593-0001LF	649-10103593-0001LF	10103593-0001LF	
11	4	R7-R10	RCV0805499KFKEA	71-RCV0805499KFKEA	499K	
13	8	TPA1-TPA4,TPB1-TPB4	5004	534-5004	N/A	
14	2	TP_ENA,TP_ENB	5002	534-5002	N/A	
15	1		EPCB1493XW		PCB	
16	1	U1 (Not Included)	MAX1493X			
DO NOT POPULATE						
12	4	SU1-SU4	969102-0000-DA	517-9691020000DA	STC02SYAN, JMP	
6	8	C5-C8,C18,C19,C23,C24	GRM2195C1H103JA01	81-GRM215C1H103JA01D		PACKOUT
7	8	R1-R6,R11,R12	ERJ-P06J472V	667-ERJ-P06J472V		PACKOUT

TOTAL 21



Стандарт Электрон Связь

Мы молодая и активно развивающаяся компания в области поставок электронных компонентов. Мы поставляем электронные компоненты отечественного и импортного производства напрямую от производителей и с крупнейших складов мира.

Благодаря сотрудничеству с мировыми поставщиками мы осуществляем комплексные и плановые поставки широчайшего спектра электронных компонентов.

Собственная эффективная логистика и склад в обеспечивает надежную поставку продукции в точно указанные сроки по всей России.

Мы осуществляем техническую поддержку нашим клиентам и предпродажную проверку качества продукции. На все поставляемые продукты мы предоставляем гарантию .

Осуществляем поставки продукции под контролем ВП МО РФ на предприятия военно-промышленного комплекса России , а также работаем в рамках 275 ФЗ с открытием отдельных счетов в уполномоченном банке. Система менеджмента качества компании соответствует требованиям ГОСТ ISO 9001.

Минимальные сроки поставки, гибкие цены, неограниченный ассортимент и индивидуальный подход к клиентам являются основой для выстраивания долгосрочного и эффективного сотрудничества с предприятиями радиоэлектронной промышленности, предприятиями ВПК и научно-исследовательскими институтами России.

С нами вы становитесь еще успешнее!

Наши контакты:

Телефон: +7 812 627 14 35

Электронная почта: sales@st-electron.ru

Адрес: 198099, Санкт-Петербург,
Промышленная ул, дом № 19, литера Н,
помещение 100-Н Офис 331