

PLEASE CHECK WWW.MOLEX.COM FOR LATEST PART INFORMATION

Part Number: [0753310444](#)
Status: **Active**
Overview: [gbx_backplane_connector_system](#)
Description: 1.85mm by 1.85mm (.073 by .073") Pitch 3-Pair GbX® Backplane Connector System, Power Module, 6 Circuits, 1.27µm (50µ") Gold (Au)

Documents:

[Drawing \(PDF\)](#) [RoHS Certificate of Compliance \(PDF\)](#)
[Product Specification PS-75221-999 \(PDF\)](#)

General

| | |
|-------------------------------|---------------------------------------------------------------------------------|
| Product Family | Backplane Connectors |
| Series | 75331 |
| Application | Backplane |
| Application Tooling Documents | Tooling Manual |
| Comments | Blade Length A 4.50mm, B 4.50mm, C 4.50mm |
| Component Type | Power Header |
| Overview | gbx_backplane_connector_system |
| Product Name | GbX® |
| Style | N/A |

Physical

| | |
|--------------------------------|--------------------------------|
| Circuits (Loaded) | 6 |
| Circuits (maximum) | 6 |
| Circuits Detail | Rows A, B & C |
| Color - Resin | Gray (Dark) |
| Durability (mating cycles max) | 200 |
| First Mate / Last Break | No |
| Guide to Mating Part | No |
| Keying to Mating Part | None |
| Material - Metal | High Performance Alloy (HPA) |
| Material - Plating Mating | Gold |
| Material - Plating Termination | Tin-Lead |
| Material - Resin | High Temperature Thermoplastic |
| Number of Columns | N/A |
| Number of Pairs | 3 |
| Number of Rows | 3 |
| Orientation | Vertical |
| PC Tail Length (in) | 0.090 In |
| PC Tail Length (mm) | 2.28 mm |
| PCB Locator | Yes |
| PCB Retention | Yes |
| PCB Thickness Recommended (in) | 0.063 In |
| PCB Thickness Recommended (mm) | 1.60 mm |
| Packaging Type | Tube |
| Pitch - Mating Interface (in) | 0.000 In |
| Pitch - Mating Interface (mm) | 0.00 mm |
| Pitch - Term. Interface (in) | 0.102 In |
| Pitch - Term. Interface (mm) | 2.60 mm |
| Plating min: Mating (µin) | 50 |
| Plating min: Mating (µm) | 1.25 |
| Plating min: Termination (µin) | 30 |
| Plating min: Termination (µm) | 0.75 |
| Polarized to PCB | Yes |
| Stackable | No |

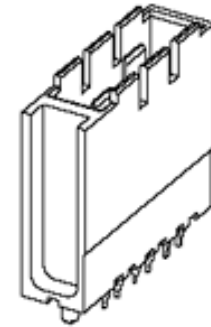

Series
image - Reference only

EU RoHS

RoHS Compliant by Exemption

REACH SVHC

Not Reviewed

Halogen-Free

Status

Not Reviewed

China RoHS



Pb

Need more information on product environmental compliance?

Email productcompliance@molex.com
 For a multiple part number RoHS Certificate of Compliance, [click here](#)

Please visit the [Contact Us](#) section for any non-product compliance questions.

Search Parts in this Series

[75331Series](#)

Mates With

[75292 GbX® Daughtercard](#)

Application Tooling | FAQ

Tooling specifications and manuals are found by selecting the products below. Crimp Height Specifications are then contained in the Application Tooling Specification document.

Global

| Description | Product # |
|------------------|----------------------------|
| GbX® Single Pin | 0622022090 |
| Repair Tool | |
| GbX® Shield | 0622022100 |
| Removal Tool | |
| GbX® 3 Pair 1-Up | 0622022580 |
| Power Module | |

| | |
|--------------------------------|------------------------------|
| Surface Mount Compatible (SMC) | Yes |
| Temperature Range - Operating | 105°C |
| Termination Interface: Style | Through Hole - Compliant Pin |

Electrical

| | |
|-------------------------------|------------------|
| Current - Maximum per Contact | 6A |
| Data Rate | 8.0 Gbps |
| Real Signals (per 25mm) | 0 |
| Shield Type | N/A |
| Shielded | No |
| Voltage - Maximum | 120V AC (RMS)/DC |

Material Info

Reference - Drawing Numbers

| | |
|-------------------------|--------------|
| Packaging Specification | PK-70873-571 |
| Product Specification | PS-75221-999 |
| Sales Drawing | SD-75331-001 |

GbX is a registered trademark of Amphenol Corporation.

This document was generated on 05/13/2010

PLEASE CHECK WWW.MOLEX.COM FOR LATEST PART INFORMATION

10 9 8 7 6 5 4 3 2 1

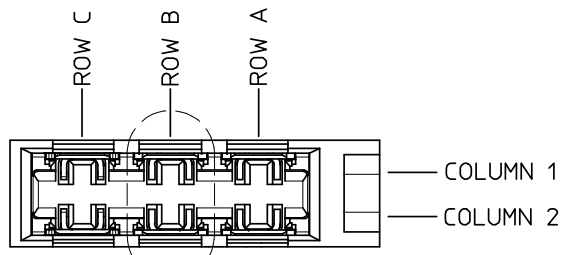

SEE NOTE 4.

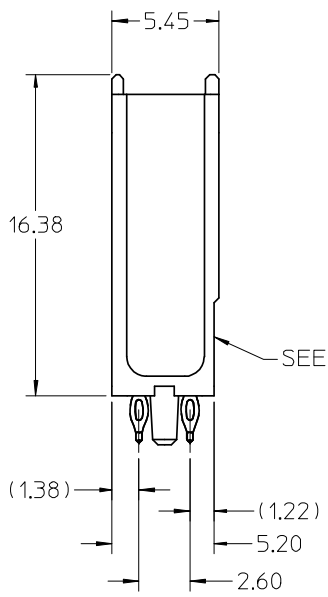
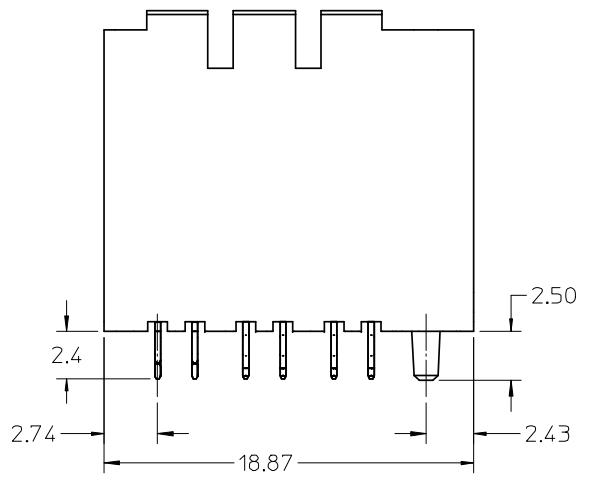

SEE NOTE 8.

- NOTES:
1. MATERIALS: HOUSING - LIQUID CRYSTAL POLYMER (LCP), UL 94V-0, GRAY; CONTACT - COPPER ALLOY.
 2. FINISH: SELECT GOLD IN CONTACT AREA, 50 μ " THICK, TIN/LEAD OR MATTE TIN IN COMPLIANT AREA.
 3. PACKAGING PER PK-70873-571.
 4. CONTACTS IN EACH ROW HAVE THE SAME WIPE LENGTH.
 5. BACKPLANE ASSEMBLY MATES WITH DAUGHTERCARD POWER MODULE 75292-3***.
 6. PART SHOWN IS 75331-0467.
 7. SEE OTHER SHEETS FOR ADDITIONAL NOTES.
 8. WHEN INSERTING OPEN SIGNAL MODULES NEXT TO COLUMN 1 SIDE OF POWER MODULES, SIGNAL MODULES MUST BE INSERTED BEFORE THE POWERS TO AVOID INTERFERENCE BETWEEN THE TWO CONNECTOR HOUSINGS.
 9. THESE PARTS CONFORM TO MOLEX PRODUCT SPECIFICATION PS-75221-999.
 10. THESE PARTS CONFORM TO MOLEX COSMETIC SPECIFICATION PS-45499-002.

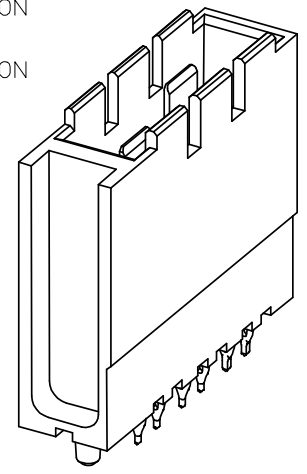

1-UP ASSEMBLY PART NUMBER

7 5 3 3 1 - 0 A B C
 - TIN/LEAD PLATED PRODUCT -
 FOR EACH ROW LOCATION A, B, C:
 0 = VOID
 4 = 4.5 mm WIPE
 6 = 6.0 mm WIPE
 7 = 7.5 mm WIPE
 - LEAD-FREE PLATED PRODUCT -
 FOR EACH ROW LOCATION A, B, C:
 0 = VOID
 2 = 4.5 mm WIPE
 3 = 6.0 mm WIPE
 5 = 7.5 mm WIPE

| | | | | | | |
|-------------------------------------------------------------------------------------------------------------------------------------|-------------------------------------------------------------------------------------------------------------------------------|-----------------------------------------------------------------------------------------------------------------|----------------------------------------------------------------------------------------------------------------------------------------------|------------------|--------------|----------------------------------------------------------|
| SPEC FILE CORRECTED EC NO: UCP2008-2380 TIDR: MNDVARVARA 2008/03/27 CHKD: JBINGHAM 2008/03/27 APPR: JBINGHAM 2008/03/31 | QUALITY SYMBOLS | GENERAL TOLERANCES (UNLESS SPECIFIED) | DIMENSION STYLE | SCALE | DESIGN UNITS | THIRD ANGLE PROJECTION |
| | ▽=0 ▽=0 | mm INCH 4 PLACES ±--- ±--- 3 PLACES ±--- ±--- 2 PLACES ±--- ±--- 1 PLACE ±--- ±--- ANGULAR ±---° | MM ONLY DRAWN BY DATE ELO 2005/02/18 CHECKED BY DATE ELO 2005/02/22 APPROVED BY DATE CUNNINGHAM 2005/02/23 MATERIAL NO. | 4:1 | METRIC | TITLE GBX 3 PAIR BACKPLANE POWER SALES ASSEMBLY |
| | DRAFT WHERE APPLICABLE MUST REMAIN WITHIN DIMENSIONS | SEE CHART | MOLEX INCORPORATED DOCUMENT NO. SD-75331-001 | SHEET NO. 1 OF 4 | | |
| | THIS DRAWING CONTAINS INFORMATION THAT IS PROPRIETARY TO MOLEX INCORPORATED AND SHOULD NOT BE USED WITHOUT WRITTEN PERMISSION | | | | | |

9 8 7 6 5 4 3 2 1

10 9 8 7 6 5 4 3 2 1

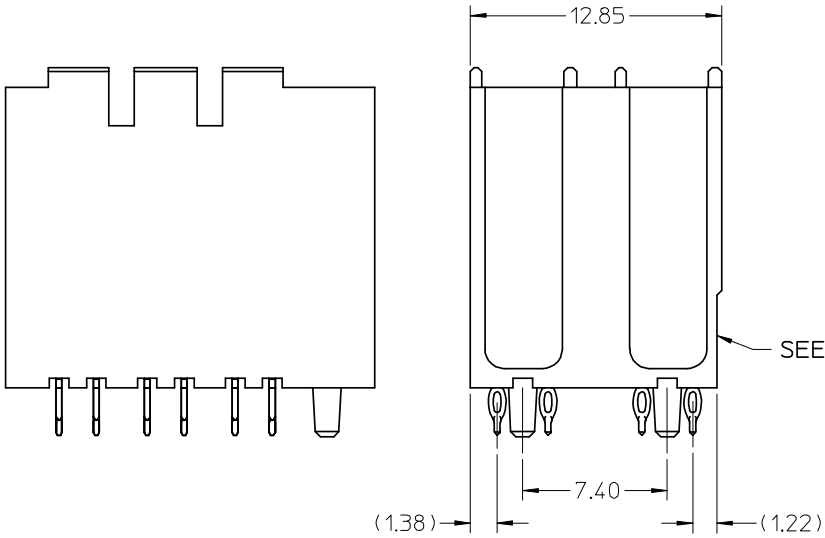
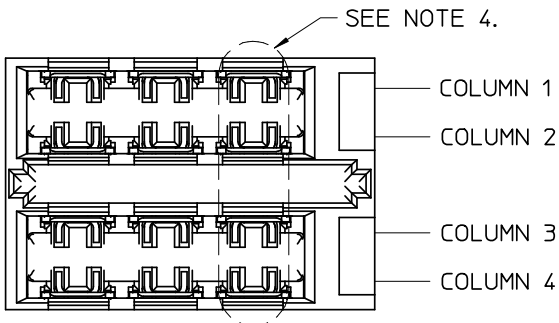

2-UP ASSEMBLY PART NUMBER

7 5 3 3 2 - 0 A B C
 - TIN/LEAD PLATED PRODUCT -
 FOR EACH ROW LOCATION A, B, C:
 0 = VOID
 4 = 4.5 mm WIPE
 6 = 6.0 mm WIPE
 7 = 7.5 mm WIPE
 - LEAD-FREE PLATED PRODUCT -
 FOR EACH ROW LOCATION A, B, C:
 0 = VOID
 2 = 4.5 mm WIPE
 3 = 6.0 mm WIPE
 5 = 7.5 mm WIPE

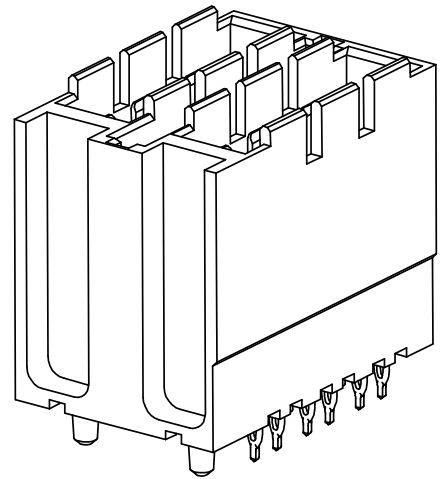

SEE SHEET 1 FOR ADDITIONAL INFORMATION
 CHECK WITH PRODUCT MANAGER FOR AVAILABILITY

| | | | | | | | | | | |
|-----------------------------------------------------------------------------------------------------------------------------|-------------------------------|---------------------------------------|---------------------------|----------------------------|------------------------------------------------------|--------------------|--------------------------------------------------------------------------|------------------------|--|--|
| SEE SHEET ONE EC NO: UCP2008-2380 TDR: DWARVARVARA 2008/03/27 CHKD: BINGHAM 2008/03/27 APPR: BINGHAM 2008/03/31 | QUALITY SYMBOLS ▽=0 ▽=0 | GENERAL TOLERANCES (UNLESS SPECIFIED) | | DIMENSION STYLE MM ONLY | | SCALE 4:1 | DESIGN UNITS METRIC | THIRD ANGLE PROJECTION | | |
| | | | mm | INCH | DRAWN BY ELO | DATE 2005/02/18 | TITLE GBX 3 PAIR BACKPLANE POWER SALES ASSEMBLY MOLEX INCORPORATED | | | |
| | | 4 PLACES | ± --- | ± --- | CHECKED BY | DATE | | | | |
| | | 3 PLACES | ± --- | ± --- | ELO | 2005/02/22 | MATERIAL NO. SEE CHART DOCUMENT NO. SD-75331-001 | | | |
| 2 PLACES | ± --- | ± --- | APPROVED BY CUNNINGHAM | DATE 2005/02/23 | | | | | | |
| 1 PLACE | ± --- | ± --- | ANGULAR ± --- ° | | DRAFT WHERE APPLICABLE MUST REMAIN WITHIN DIMENSIONS | | SHEET NO. 2 OF 4 | | | |

9 8 7 6 5 4 3 2 1

10 9 8 7 6 5 4 3 2 1

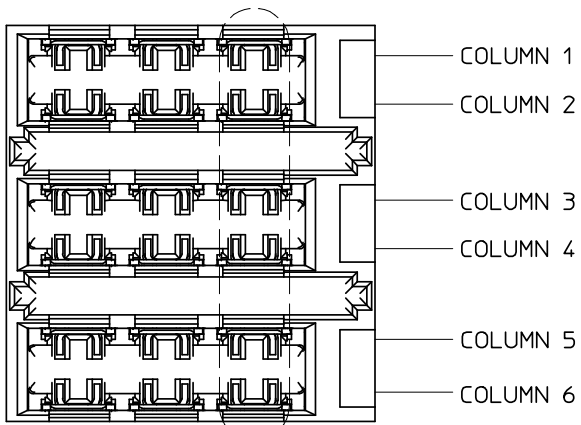

3-UP ASSEMBLY PART NUMBER

7 5 3 3 3 - 0 A B C
 - TIN/LEAD PLATED PRODUCT -
 FOR EACH ROW LOCATION A, B, C:
 0 = VOID
 4 = 4.5 mm WIPE
 6 = 6.0 mm WIPE
 7 = 7.5 mm WIPE
 - LEAD-FREE PLATED PRODUCT -
 FOR EACH ROW LOCATION A, B, C:
 0 = VOID
 2 = 4.5 mm WIPE
 3 = 6.0 mm WIPE
 5 = 7.5 mm WIPE

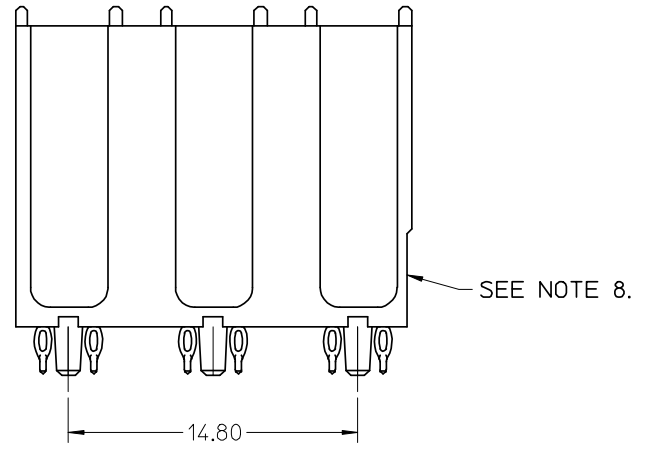
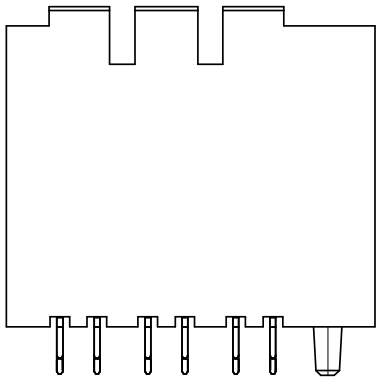
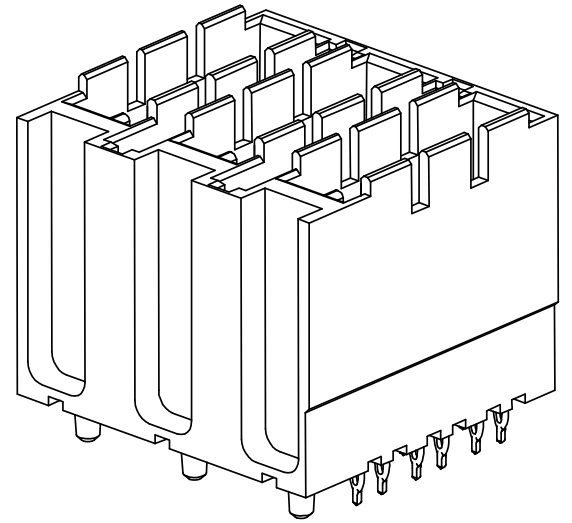

SEE SHEET 1 FOR ADDITIONAL INFORMATION
 CHECK WITH PRODUCT MANAGER FOR AVAILABILITY

| | | | | | | | | | | | |
|------------------------------------------------------------------------------------------------------------------------------|-----------------|-----------------|---------------------------------------|----------------------|------------------------------------------------------|---------------------|-------------------------------------------------------------------------------------------------------------------------------|--------------|-------------------------------------------|--|--|
| SEE SHEET ONE EC NO: UCP2008-2380 TDR: DWARVARA 2008/03/27 CHKD: J. INGHAM 2008/03/27 APPR: J. INGHAM 2008/03/31 | REV DESCRIPTION | QUALITY SYMBOLS | GENERAL TOLERANCES (UNLESS SPECIFIED) | | DIMENSION STYLE | | SCALE | DESIGN UNITS | THIRD ANGLE PROJECTION | | |
| | | ▽=0 ∇=0 | mm | INCH | MM ONLY | | 4:1 | METRIC | | | |
| | | | 4 PLACES ± --- ± --- | 3 PLACES ± --- ± --- | 2 PLACES ± --- ± --- | 1 PLACE ± --- ± --- | DRAWN BY | DATE | TITLE | | |
| | | | ANGULAR ± --- ° | | DRAFT WHERE APPLICABLE MUST REMAIN WITHIN DIMENSIONS | | ELO | 2005/02/18 | GBX 3 PAIR BACKPLANE POWER SALES ASSEMBLY | | |
| | | | | | CHECKED BY | DATE | MOLEX INCORPORATED | | | | |
| | | | | | ELO | 2005/02/22 | SD-75331-001 | | | | |
| | | | | | APPROVED BY | DATE | SHEET NO. | | | | |
| | | | | | CUNNINGHAM | 2005/02/23 | 3 OF 4 | | | | |
| | | | | | MATERIAL NO. | | THIS DRAWING CONTAINS INFORMATION THAT IS PROPRIETARY TO MOLEX INCORPORATED AND SHOULD NOT BE USED WITHOUT WRITTEN PERMISSION | | | | |
| | | | | | SEE CHART | | | | | | |
| | | | | | SIZE B | | | | | | |

9 8 7 6 5 4 3 2 1

10 9 8 7 6 5 4 3 2 1

SEE NOTE 5.

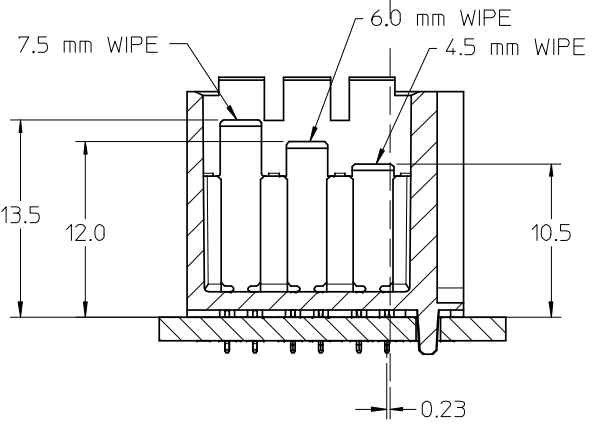
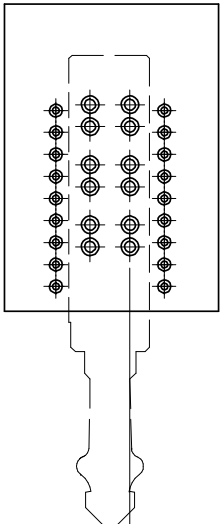
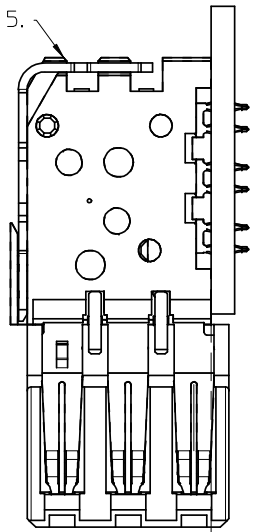

DC BOARD EDGE TO CENTERLINE OF BP TAIL

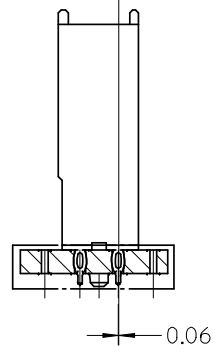

HOLE PATTERN FOR 1-UP ASSEMBLY

- 1.) ADD 7.40 FROM CENTERLINES OF PEGS FOR MULTIPLE UP ASSEMBLIES.
- 2.) ADD 5.55 FROM CENTERLINE TO CENTERLINE OF PEG FOR INDIVIDUAL POWER MODULES STACKED NEXT TO EACH OTHER.

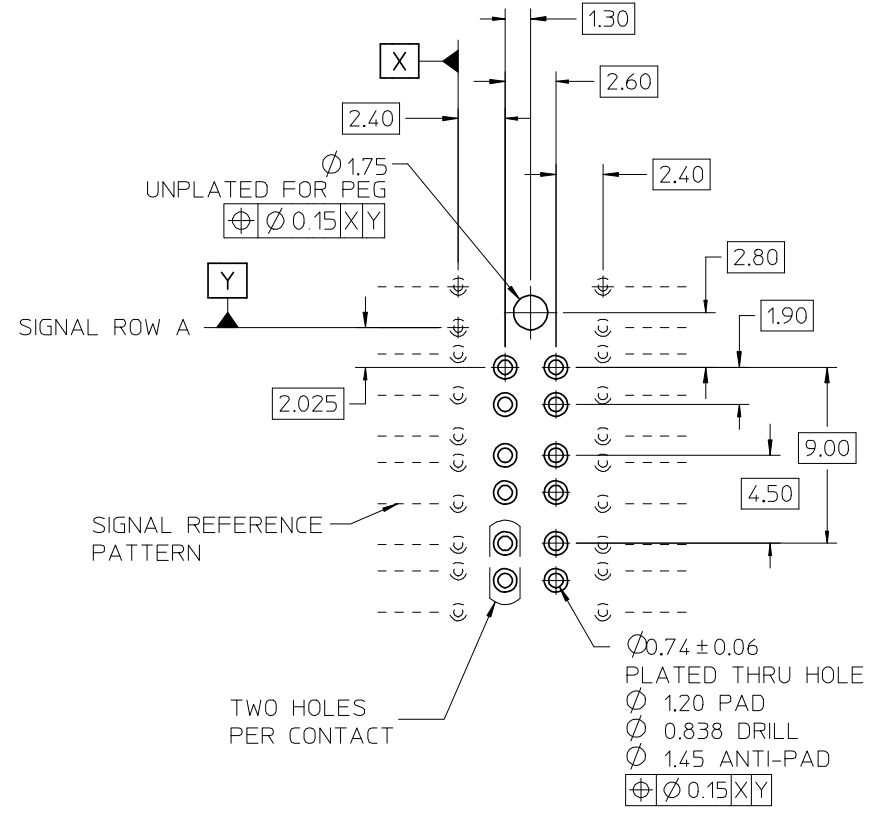

| | | | | | | | |
|---------------------------------------------------------------------------------------------------------------------------------|--------------------|-----------------|--------------------------------------------------------------------------------------------------------------------------------------------------------------------|-------------------------------------------------------------------------------------------------------------------------------|-------------------------------------------|---------------------------|------------------------|
| SEE SHEET ONE EC NO: UCP2008-2380 TDRWN: DIVARVARA 2008/03/27 CHKD: JB INGHAM 2008/03/27 APPR: JB INGHAM 2008/03/31 | DESCRIPTION REV | QUALITY SYMBOLS | GENERAL TOLERANCES (UNLESS SPECIFIED) mm INCH 4 PLACES ± --- ± --- 3 PLACES ± --- ± --- 2 PLACES ± --- ± --- 1 PLACE ± --- ± --- ANGULAR ± --- ° | DIMENSION STYLE | SCALE | DESIGN UNITS | THIRD ANGLE PROJECTION |
| | | MM ONLY | | 4:1 | METRIC | | |
| | | DRAWN BY | | DATE | TITLE | | |
| | | ELO | | 2005/02/18 | GBX 3 PAIR BACKPLANE POWER SALES ASSEMBLY | | |
| | | CHECKED BY | DATE | MOLEX INCORPORATED | | DOCUMENT NO. SD-75331-001 | |
| | | ELO | 2005/02/22 | | | | |
| | | APPROVED BY | DATE | MOLEX INCORPORATED | | SHEET NO. 4 OF 4 | |
| | | CUNNINGHAM | 2005/02/23 | | | | |
| | | MATERIAL NO. | SEE PREVIOUS | THIS DRAWING CONTAINS INFORMATION THAT IS PROPRIETARY TO MOLEX INCORPORATED AND SHOULD NOT BE USED WITHOUT WRITTEN PERMISSION | | | |
| | | SIZE | B | | | | |

9 8 7 6 5 4 3 2 1



Стандарт Электрон Связь

Мы молодая и активно развивающаяся компания в области поставок электронных компонентов. Мы поставляем электронные компоненты отечественного и импортного производства напрямую от производителей и с крупнейших складов мира.

Благодаря сотрудничеству с мировыми поставщиками мы осуществляем комплексные и плановые поставки широчайшего спектра электронных компонентов.

Собственная эффективная логистика и склад в обеспечивает надежную поставку продукции в точно указанные сроки по всей России.

Мы осуществляем техническую поддержку нашим клиентам и предпродажную проверку качества продукции. На все поставляемые продукты мы предоставляем гарантию .

Осуществляем поставки продукции под контролем ВП МО РФ на предприятия военно-промышленного комплекса России , а также работаем в рамках 275 ФЗ с открытием отдельных счетов в уполномоченном банке. Система менеджмента качества компании соответствует требованиям ГОСТ ISO 9001.

Минимальные сроки поставки, гибкие цены, неограниченный ассортимент и индивидуальный подход к клиентам являются основой для выстраивания долгосрочного и эффективного сотрудничества с предприятиями радиоэлектронной промышленности, предприятиями ВПК и научно-исследовательскими институтами России.

С нами вы становитесь еще успешнее!

Наши контакты:

Телефон: +7 812 627 14 35

Электронная почта: sales@st-electron.ru

Адрес: 198099, Санкт-Петербург,
Промышленная ул, дом № 19, литера Н,
помещение 100-Н Офис 331