

BATTERY PROTECTION IC WITH CELL-BALANCE FUNCTION

The S-8209B Series is a protection IC for lithium-ion / lithium polymer rechargeable batteries and includes a high-accuracy voltage detection circuit and a delay circuit.

The S-8209B Series has a transmission function and two types of cell-balance function so that users are also able to configure a protection circuit with series multi-cell.

■ Features

- High-accuracy voltage detection circuit

Overcharge detection voltage* ¹	3.55 V to 4.40 V (5 mV step)	Accuracy ±25 mV
Overcharge release voltage* ¹	3.50 V to 4.40 V* ²	Accuracy ±50 mV
Cell-balance detection voltage* ¹	3.55 V to 4.40 V (5 mV step)* ³	Accuracy ±25 mV
Cell-balance release voltage* ¹	3.50 V to 4.40 V* ⁴	Accuracy ±50 mV
Overdischarge detection voltage	2.0 V to 3.0 V (10 mV step)	Accuracy ±50 mV
Overdischarge release voltage	2.0 V to 3.4 V* ⁵	Accuracy ±100 mV
- Settable delay time by external capacitor for output pin
- Control charging, discharging, cell-balance by CTLC pin, CTLD pin
- Two types of cell-balance function; charge / discharge*⁶
- Wide range of operation temperature Ta = -40°C to +85°C
- Low current consumption 7.0 μA max.
- Lead-free, Sn 100%, halogen-free*⁷

*1. Regarding selection of overcharge detection voltage, overcharge release voltage, cell-balance detection voltage and cell-balance release voltage, refer to **Remark 3** in "**3. Product name list**" of "**■ Product Name Structure**".

*2. Overcharge release voltage = Overcharge detection voltage – Overcharge hysteresis voltage
(Overcharge hysteresis voltage is selectable in 0 V to 0.4 V in 50 mV step.)

*3. Select as to overcharge detection voltage > cell-balance detection voltage.

*4. Cell-balance release voltage = Cell-balance detection voltage – Cell-balance hysteresis voltage
(Cell-balance hysteresis voltage is selectable in 0 V to 0.4 V in 50 mV step.)

*5. Overdischarge release voltage = Overdischarge detection voltage + Overdischarge hysteresis voltage
(Overdischarge hysteresis voltage is selectable in 0 V to 0.7 V in 100 mV step.)

*6. Also available the product without discharge cell-balance function

*7. Refer to "**■ Product Name Structure**" for details.

■ Applications

- Lithium-ion rechargeable battery pack
- Lithium polymer rechargeable battery pack

■ Packages

- SNT-8A
- 8-Pin TSSOP

■ **Block Diagram**

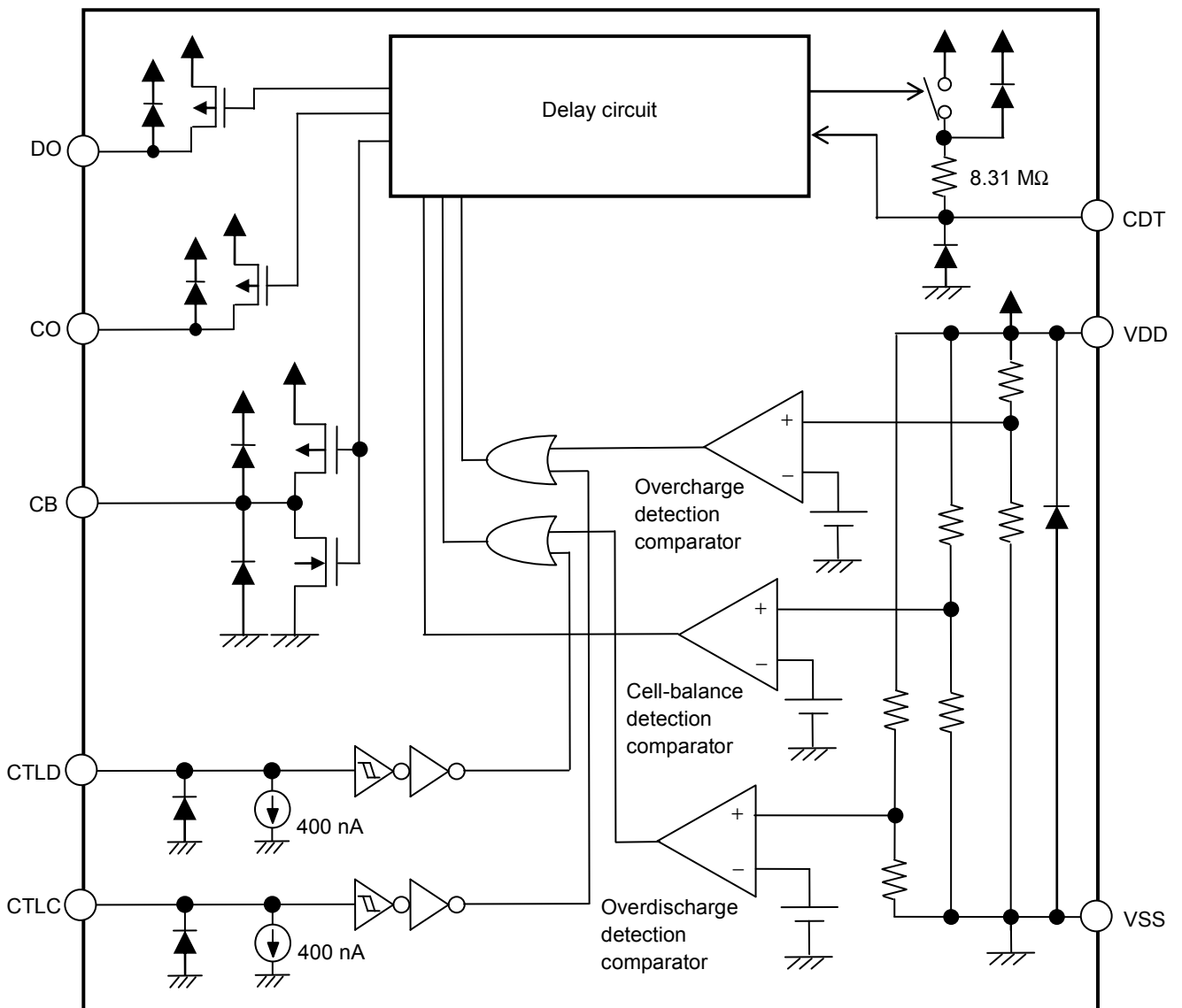

Remark The diodes in the IC are parasitic diodes.

Figure 1

■ Product Name Structure

1. Product name

1.1 8-Pin TSSOP

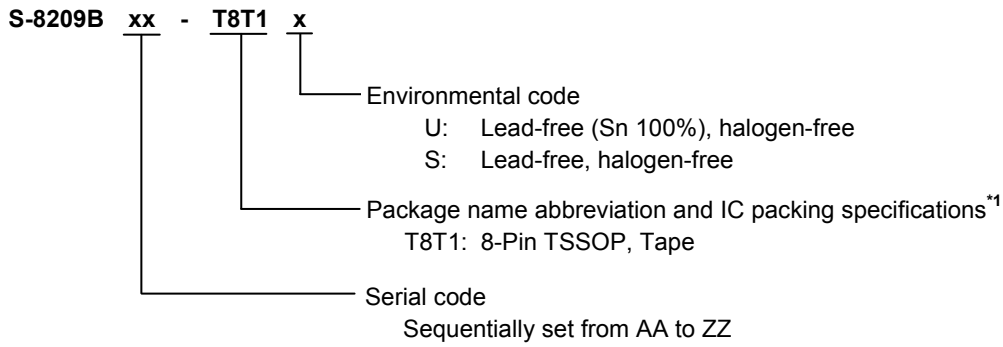

*1. Refer to the tape drawing.

1.2 SNT-8A

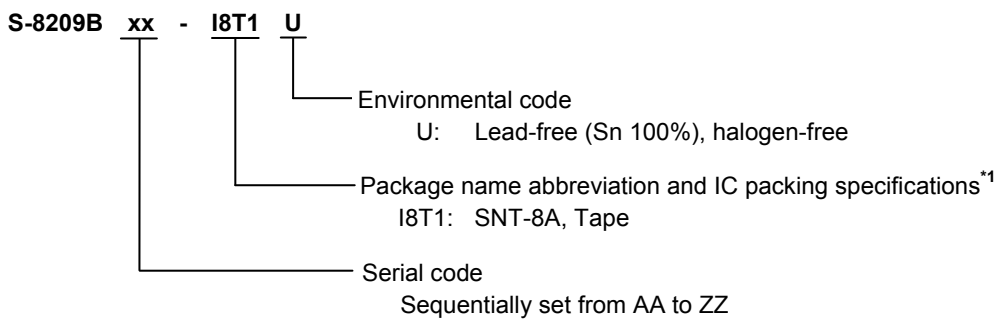

*1. Refer to the tape drawing.

2. Packages

Table 1 Package Drawing Codes

Package Name		Dimension	Tape	Reel	Land
8-Pin TSSOP	Environmental code = S	FT008-A-P-SD	FT008-E-C-SD	FT008-E-R-SD	-
	Environmental code = U	FT008-A-P-SD	FT008-E-C-SD	FT008-E-R-S1	
SNT-8A		PH008-A-P-SD	PH008-A-C-SD	PH008-A-R-SD	PH008-A-L-SD

3. Product name list

3.1 8-Pin TSSOP

Table 2

Product Name	Overcharge Detection Voltage (V _{CU})	Overcharge Release Voltage (V _{CL})	Cell-balance Detection Voltage (V _{BU})	Cell-balance Release Voltage (V _{BL})	Overdischarge Detection Voltage (V _{DL})	Overdischarge Release Voltage (V _{DU})	Discharge Cell-balance Function
S-8209BAA-T8T1y	4.100 V	4.000 V	4.050 V	4.000 V	2.50 V	2.70 V	Yes
S-8209BAD-T8T1y	4.150 V	3.950 V	3.900 V	3.900 V	2.00 V	2.70 V	Yes
S-8209BAG-T8T1y	3.800 V	3.650 V	3.700 V	3.700 V	2.20 V	2.50 V	No
S-8209BAH-T8T1y	4.250 V	4.150 V	4.200 V	4.200 V	2.50 V	2.80 V	No
S-8209BAI-T8T1y	4.250 V	4.150 V	4.100 V	4.050 V	2.50 V	2.70 V	Yes
S-8209BAJ-T8T1y	4.150 V	3.950 V	3.900 V	3.900 V	2.30 V	3.00 V	No
S-8209BAK-T8T1y	4.215 V	4.215 V	4.190 V	4.190 V	2.00 V	2.50 V	Yes
S-8209BAL-T8T1y	4.300 V	4.100 V	4.225 V	4.225 V	2.00 V	2.50 V	Yes
S-8209BAN-T8T1U	4.250 V	4.150 V	4.200 V	4.200 V	2.00 V	2.10 V	No

3.2 SNT-8A

Table 3

Product Name	Overcharge Detection Voltage (V _{CU})	Overcharge Release Voltage (V _{CL})	Cell-balance Detection Voltage (V _{BU})	Cell-balance Release Voltage (V _{BL})	Overdischarge Detection Voltage (V _{DL})	Overdischarge Release Voltage (V _{DU})	Discharge Cell-balance Function
S-8209BAA-I8T1U	4.100 V	4.000 V	4.050 V	4.000 V	2.50 V	2.70 V	Yes
S-8209BAM-I8T1U	4.000 V	3.800 V	3.900 V	3.850 V	3.00 V	3.40 V	No

Remark 1. y: S or U

2. Please select products of environmental code = U for Sn 100%, halogen-free products.

3. Please contact our sales office for the products with detection voltage value other than those specified above.

Users are able to select the overcharge detection voltage, overcharge release voltage, cell-balance detection voltage and cell-balance release voltage from the range shown in **Figure 2** and **Figure 3**.

Users are able to select how to combine the overcharge detection voltage (V_{CU}) and the overcharge release voltage (V_{CL}) from the range A or B shown in **Figure 2**^{*1}.

Similarly, select how to combine the cell-balance detection voltage (V_{BU}) and the cell-balance release voltage (V_{BL}) from the range of C or D in **Figure 3**^{*2}.

In selecting the combination of V_{CU} and V_{CL} from the range A, select the combination of V_{BU} and V_{BL} from the range C. Similarly, in selecting the combination of V_{CU} and V_{CL} from the B range, select the combination of V_{BU} and V_{BL} from the range D^{*3}.

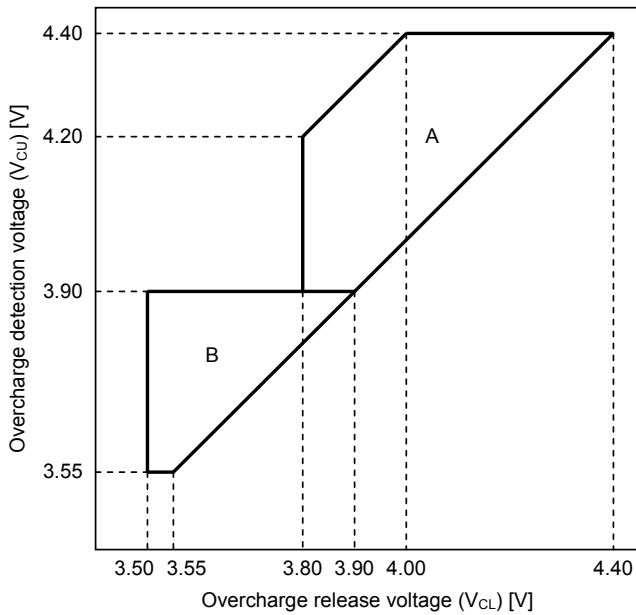

Figure 2

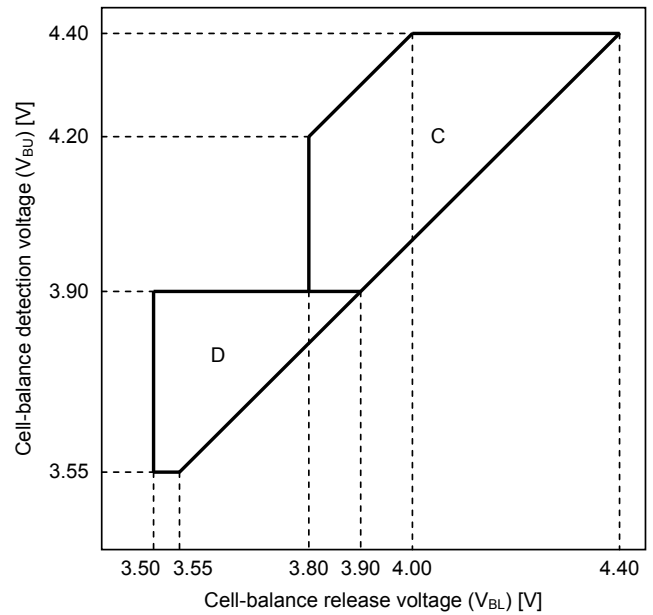

Figure 3

- *1. Users are able to select the overcharge hysteresis voltage ($V_{CU} - V_{CL}$) in 0 V to 0.4 V, in 50 mV step.
- *2. Users are able to select the cell-balance hysteresis voltage ($V_{BU} - V_{BL}$) in 0 V to 0.4 V, in 50 mV step.
- *3. Select as to set $V_{CU} > V_{BU}$.

■ **Pin Configurations**

1. 8-Pin TSSOP

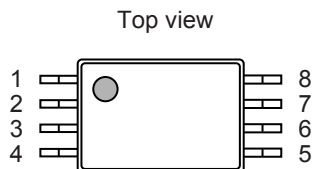

Figure 4

Table 4

Pin No.	Symbol	Description
1	CTLIC	Pin for charge control
2	CTLD	Pin for discharge control
3	VDD	Input pin for positive power supply; Connection pin for battery's positive voltage
4	CDT	Capacitor connection pin for overcharge detection delay, cell-balance detection delay and overdischarge detection delay
5	VSS	Input pin for negative power supply; Connection pin for batter's negative voltage
6	DO	Output pin for discharge control (Pch open-drain output)
7	CO	Output pin for charge control (Pch open-drain output)
8	CB	Output pin for cell-balance control (CMOS output)

2. SNT-8A

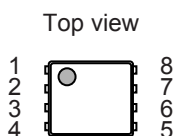

Figure 5

Table 5

Pin No.	Symbol	Description
1	CTLIC	Pin for charge control
2	CTLD	Pin for discharge control
3	VDD	Input pin for positive power supply; Connection pin for battery's positive voltage
4	CDT	Capacitor connection pin for overcharge detection delay, cell-balance detection delay and overdischarge detection delay
5	VSS	Input pin for negative power supply; Connection pin for battery's negative voltage
6	DO	Output pin for discharge control (Pch open-drain output)
7	CO	Output pin for charge control (Pch open-drain output)
8	CB	Output pin for cell-balance control (CMOS output)

■ **Absolute Maximum Ratings**

Table 6

(Ta = +25°C unless otherwise specified)

Item	Symbol	Applied pin	Absolute Maximum Rating	Unit	
Input voltage between VDD and VSS	V _{DS}	VDD	V _{SS} - 0.3 to V _{SS} + 12	V	
CB pin output voltage	V _{CB}	CB	V _{SS} - 0.3 to V _{DD} + 0.3	V	
CDT pin voltage	V _{CDT}	CDT	V _{SS} - 0.3 to V _{DD} + 0.3	V	
DO pin output voltage	V _{DO}	DO	V _{DD} - 24 to V _{DD} + 0.3	V	
CO pin output voltage	V _{CO}	CO	V _{DD} - 24 to V _{DD} + 0.3	V	
CTLC pin input voltage	V _{CTLC}	CTLC	V _{SS} - 0.3 to V _{SS} + 24	V	
CTLD pin input voltage	V _{CTLD}	CTLD	V _{SS} - 0.3 to V _{SS} + 24	V	
Power dissipation	8-Pin TSSOP	P _D	-	700*1	mW
	SNT-8A			450*1	mW
Operating ambient temperature	T _{opr}	-	-40 to +85	°C	
Storage temperature	T _{stg}	-	-55 to +125	°C	

*1. When mounted on board

[Mounted board]

- (1) Board size: 114.3 mm × 76.2 mm × t1.6 mm
- (2) Board name: JEDEC STANDARD51-7

Caution The absolute maximum ratings are rated values exceeding which the product could suffer physical damage. These values must therefore not be exceeded under any conditions.

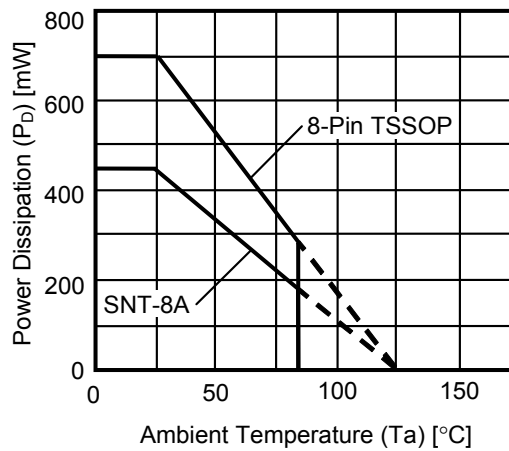

Figure 6 Power Dissipation of Package (When mounted on board)

■ **Electrical Characteristics**

Table 7

(Ta = +25°C unless otherwise specified)

Item	Symbol	Condition	Min.	Typ.	Max.	Unit	Test Circuit
Overcharge detection voltage	V _{CU}	–	V _{CU} – 0.025	V _{CU}	V _{CU} + 0.025	V	1
Overcharge release voltage	V _{CL}	V _{CL} ≠ V _{CU}	V _{CL} – 0.05	V _{CL}	V _{CL} + 0.05	V	1
		V _{CL} = V _{CU}	V _{CL} – 0.05	V _{CL}	V _{CL} + 0.025	V	1
Cell-balance detection voltage	V _{BU}	–	V _{BU} – 0.025	V _{BU}	V _{BU} + 0.025	V	1
Cell-balance release voltage	V _{BL}	V _{BL} ≠ V _{BU}	V _{BL} – 0.05	V _{BL}	V _{BL} + 0.05	V	1
		V _{BL} = V _{BU}	V _{BL} – 0.05	V _{BL}	V _{BL} + 0.025	V	1
Overdischarge detection voltage	V _{DL}	–	V _{DL} – 0.05	V _{DL}	V _{DL} + 0.05	V	1
Overdischarge release voltage	V _{DU}	–	V _{DU} – 0.10	V _{DU}	V _{DU} + 0.10	V	1
CDT pin resistance*1	R _{CDT}	V _{DS} = 3.5 V, V _{CDDT} = 0 V	4.76	8.31	10.9	MΩ	2
CDT pin detection voltage*1	V _{CDET}	V _{DS} = 3.5 V	V _{DS} × 0.65	V _{DS} × 0.70	V _{DS} × 0.75	V	3
Operating voltage between VDD and VSS	V _{DSOP}	Output voltage of CO pin, DO pin and CB pin are determined	1.5	–	8.0	V	–
CTLCH pin H voltage	V _{CTLCH}	V _{DS} = 3.5 V	V _{DS} × 0.55	–	V _{DS} × 0.90	V	4
CTLDH pin H voltage	V _{CTLDH}	V _{DS} = 3.5 V	V _{DS} × 0.55	–	V _{DS} × 0.90	V	4
CTLCL pin L voltage	V _{CTLCL}	V _{DS} = 3.5 V	V _{DS} × 0.10	–	V _{DS} × 0.45	V	4
CTLDL pin L voltage	V _{CTLDL}	V _{DS} = 3.5 V	V _{DS} × 0.10	–	V _{DS} × 0.45	V	4
Current consumption during operation*2	I _{OPE}	V _{DS} = 3.5 V	–	3.5	7.0	μA	5
Sink current CTLCH*2	I _{CTLCL}	V _{DS} = 3.5 V, V _{CTLCH} = 3.5 V	320	400	480	nA	6
Sink current CTLDH*2	I _{CTLDL}	V _{DS} = 3.5 V, V _{CTLDH} = 3.5 V	320	400	480	nA	6
Source current CB	I _{CBH}	V _{CB} = 4.0 V, V _{DS} = 4.5 V	30	–	–	μA	7
Sink current CB	I _{CBL}	V _{CB} = 0.5 V, V _{DS} = 3.5 V	30	–	–	μA	7
Source current CO	I _{COH}	V _{CO} = 3.0 V, V _{DS} = 3.5 V	30	–	–	μA	7
Leakage current CO	I _{COL}	V _{CO} = 24 V, V _{DS} = 4.5 V	–	–	0.1	μA	8
Source current DO	I _{DOH}	V _{DO} = 3.0 V, V _{DS} = 3.5 V	30	–	–	μA	7
Leakage current DO	I _{DOL}	V _{DO} = 24 V, V _{DS} = 1.8 V	–	–	0.1	μA	8

*1. In the S-8209B Series, users are able to set delay time for the output pins. By using the following formula, delay time is calculated with the value of CDT pin's resistance in the IC (R_{CDT}) and the value of capacitor set externally at the CDT pin (C_{CDT}).

$$\begin{aligned}
 t_D [s] &= -\ln(1 - V_{CDET} / V_{DS}) \times C_{CDT} [\mu F] \times R_{CDT} [M\Omega] \\
 &= -\ln(1 - 0.7 \text{ (typ.)}) \times C_{CDT} [\mu F] \times 8.31 \text{ M}\Omega \text{ (typ.)} \\
 &= 10.0 \text{ M}\Omega \text{ (typ.)} \times C_{CDT} [\mu F]
 \end{aligned}$$

In case of the capacitance of CDT pin C_{CDT} = 0.01 μF, the output pin delay time t_D is calculated by using the above formula and as follows.

$$t_D [s] = 10.0 \text{ M}\Omega \text{ (typ.)} \times 0.01 \mu F = 0.1 \text{ s (typ.)}$$

Test R_{CDT} and the CDT pin detection voltage (V_{CDET}) by test circuits shown in this datasheet after applying the power supply while pulling-up the CTLCH pin, CTLDH pin to the level of VDD pin outside the IC.

*2. In case of using CTLCH pin, CTLDH pin pulled-up to the level of VDD pin externally, the current flows from the VSS pin (I_{SS}) is calculated by the following formula.

$$I_{SS} = I_{OPE} + I_{CTLCL} + I_{CTLDL}$$

■ **Test Circuits**

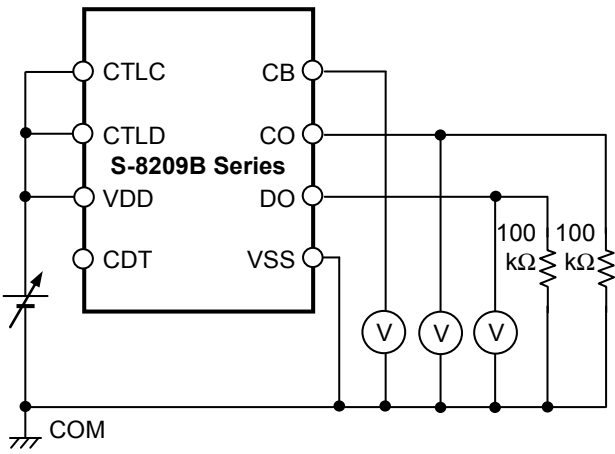

Figure 7 Test circuit 1

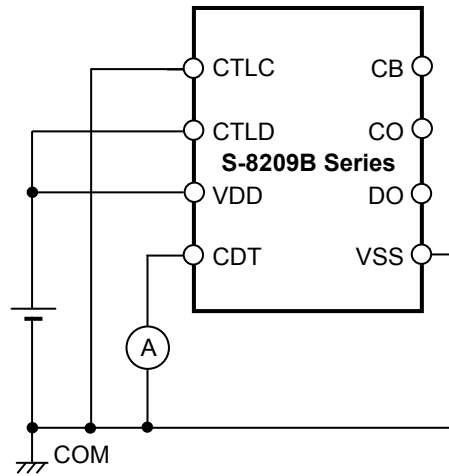

Figure 8 Test circuit 2

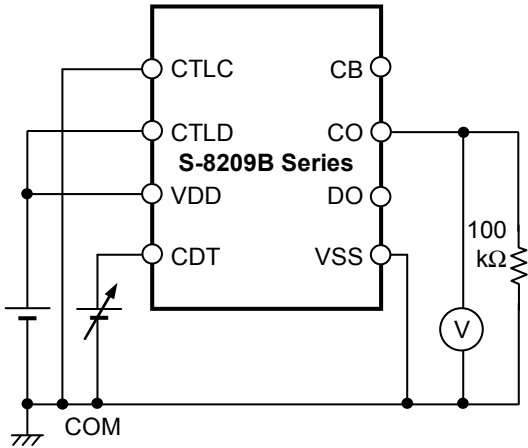

Figure 9 Test circuit 3

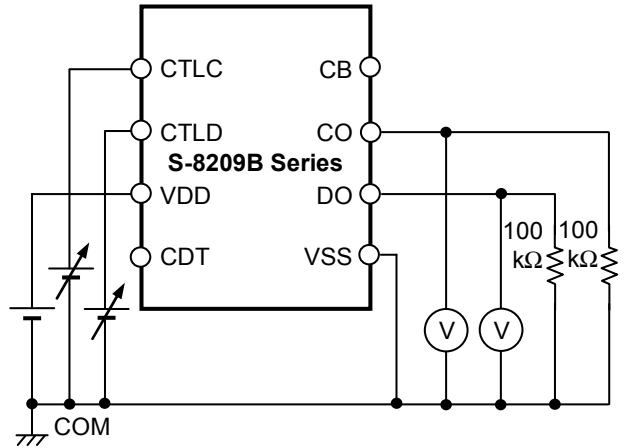

Figure 10 Test circuit 4

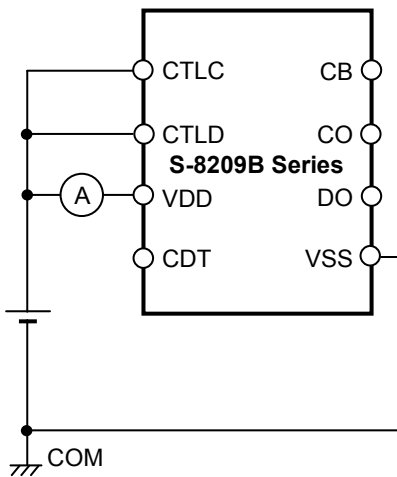

Figure 11 Test circuit 5

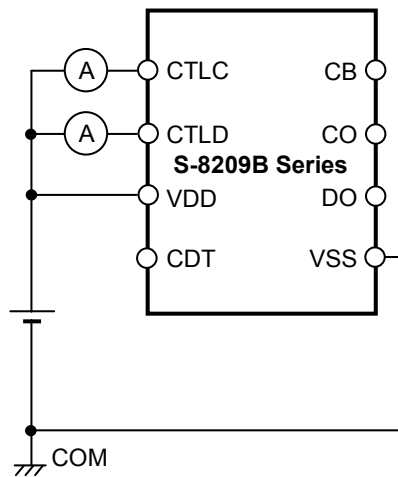

Figure 12 Test circuit 6

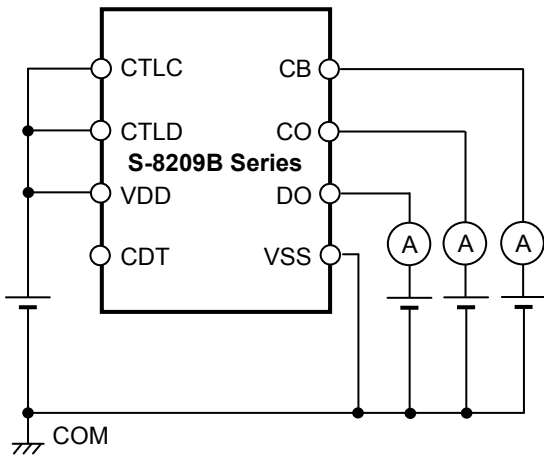

Figure 13 Test circuit 7

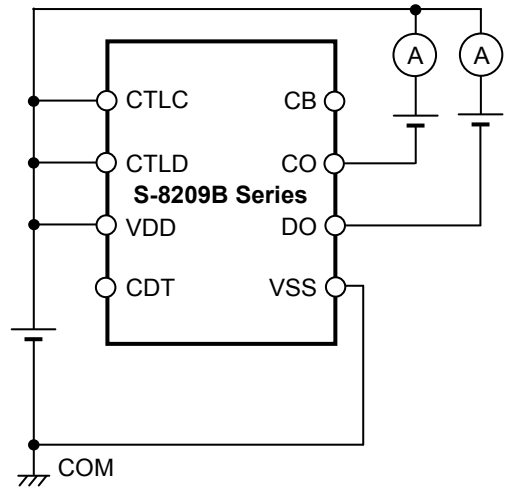

Figure 14 Test circuit 8

■ Operation

Figure 15 shows the operation transition of the S-8209B Series

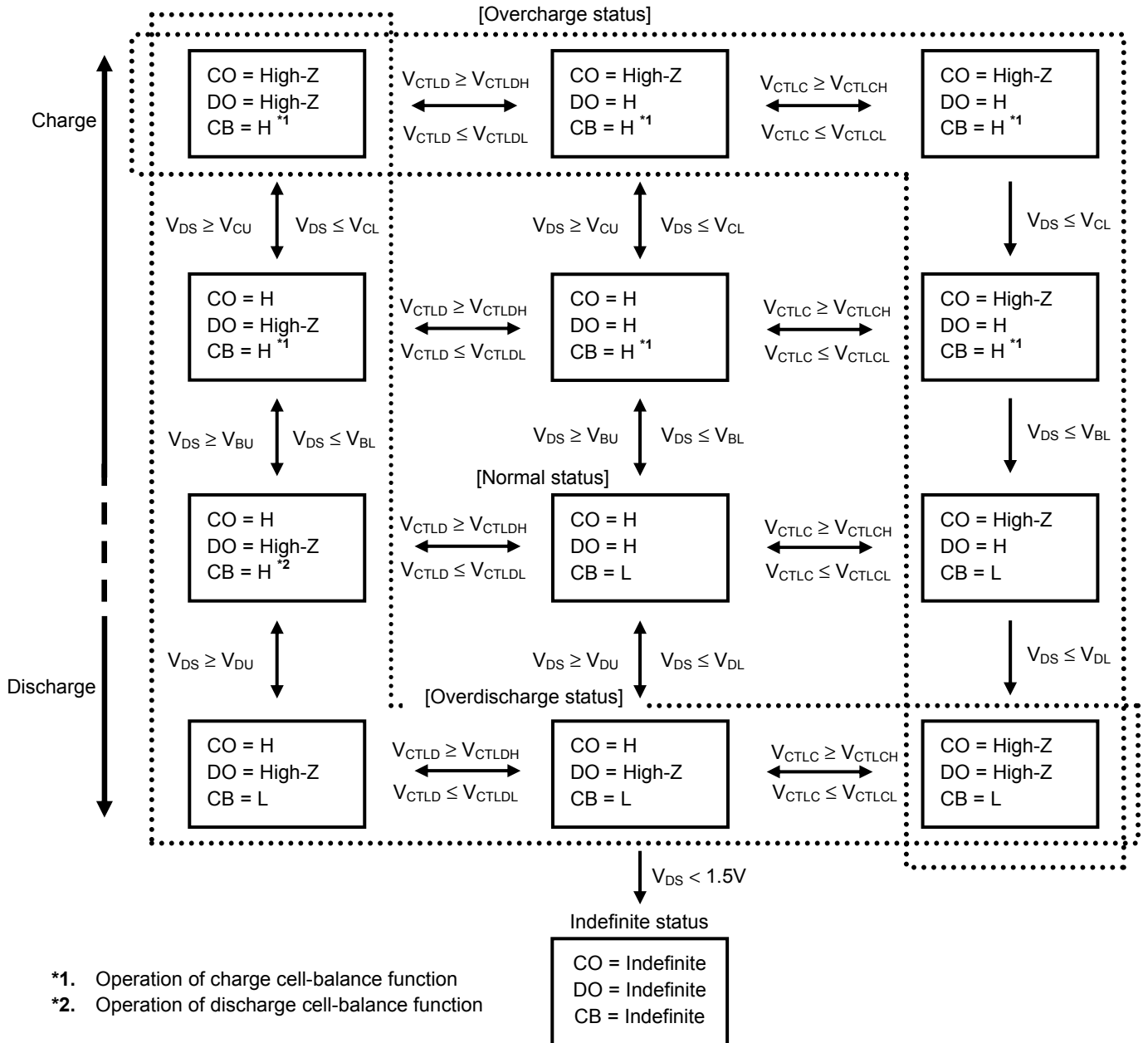

Figure 15 Operation Transition

1. Normal status

In the S-8209B Series, both of CO and DO pin get the V_{DD} level; the voltage between V_{DD} and V_{SS} (V_{DS}) is more than the overdischarge detection voltage (V_{DL}), and is less than the overcharge detection voltage (V_{CU}) and respectively, the CTLC pin input voltage (V_{CTLC}) > the CTLC pin voltage "L" ($V_{CTLC(L)}$), the CTLD pin input voltage (V_{CTLD}) > the CTLD pin voltage "L" ($V_{CTLD(L)}$). This is the normal status.

2. Overcharge status

In the S-8209B Series, the CO pin is in high impedance; when V_{DS} gets V_{CU} or more, or V_{CTLC} gets $V_{CTLC(L)}$ or less. This is the overcharge status.

If V_{DS} gets the overcharge release voltage (V_{CL}) or less, and V_{CTLC} gets the CTLC pin voltage "H" ($V_{CTLC(H)}$) or more, the S-8209B Series releases the overcharge status to return to the normal status.

3. Overdischarge status

In the S-8209B Series, the DO pin is in high impedance; when V_{DS} gets V_{DL} or less, or V_{CTLD} gets $V_{CTLD(L)}$ or less. This is the overdischarge status.

If V_{DS} gets the overdischarge release voltage (V_{DU}) or more, and V_{CTLD} gets the CTLD pin voltage "H" ($V_{CTLD(H)}$) or more, the S-8209B Series releases the overdischarge status to return to the normal status.

4. Cell-balance function

In the S-8209B Series, the CB pin gets the level of V_{DD} pin; when V_{DS} gets the cell-balance detection voltage (V_{BU}) or more. This is the charge cell-balance function.

If V_{DS} gets the cell-balance release voltage (V_{BL}) or less again, the S-8209B Series sets the CB pin the level of V_{SS} pin.

In addition, the CB pin gets the level of V_{DD} pin; when V_{DS} is more than V_{DL} , and V_{CTLD} is $V_{CTLD(L)}$ or less. This is the discharge cell-balance function.

If V_{CTLD} gets $V_{CTLD(H)}$ or more, or V_{DS} is V_{DL} or less again, the S-8209B Series sets the CB pin the level of V_{SS} pin.

5. Delay circuit

In the S-8209B Series, users are able to set delay time which is from detection of changes in V_{DS} , V_{CTLC} , V_{CTLD} to output to the CO, DO, CB pin.

For example in the detection of overcharge status, when V_{DS} exceeds V_{CU} , or V_{CTLC} gets $V_{CTLC(L)}$ or less, charging to C_{CDT} starts via R_{CDT} . If the voltage between CDT and V_{SS} (V_{CDT}) reaches the CDT pin detection voltage (V_{CDET}), the CO pin is in high impedance. The output pin delay time t_D is calculated by the following formula.

$$t_D [s] = 10.0 \text{ M}\Omega (\text{typ.}) \times C_{CDT} [\mu\text{F}]$$

The electric charge in C_{CDT} starts to be discharged when the delay time has finished.

The delay time that users have set for the CO pin, as seen above, is settable for each output pin DO, CB.

■ **Battery Protection IC Connection Examples**

Regarding the operation of protection circuit with the S-8209B Series for series-connected batteries, refer to the application note "S-8209B Series Usage Guidelines".

1. Example of Protection Circuit with the S-8209B Series (Without Discharge Cell-balance Function) for Series Multi-Cells

Figure 16 shows the example of protection circuit with the S-8209B Series (without discharge cell-balance function) for series multi-cells.

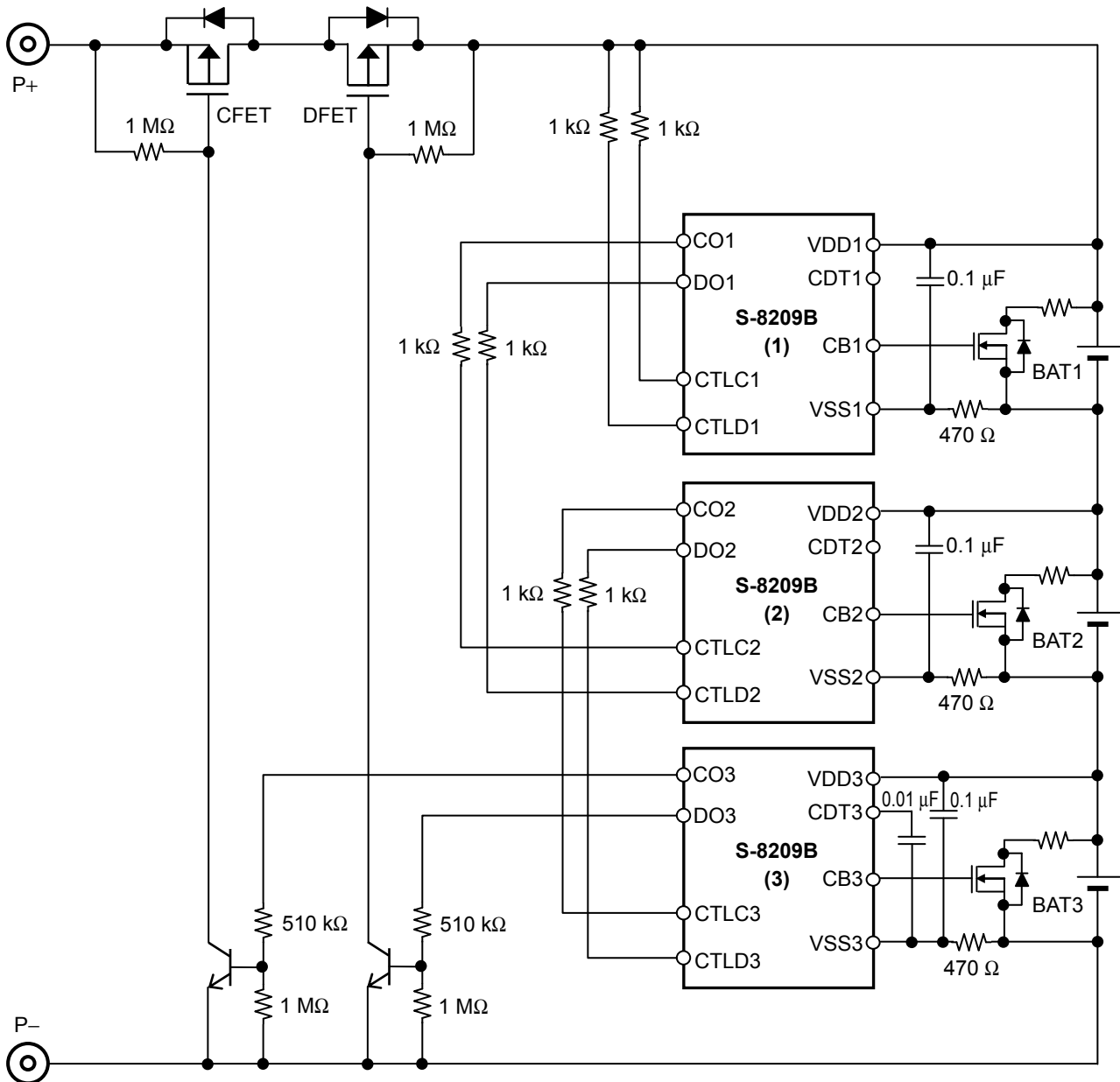

Figure 16

- Caution 1.** The above constants may be changed without notice.
2. The example of connection shown above and the constant do not guarantee proper operation. Perform thorough evaluation using the actual application to set the constant.

2. Example of Protection Circuit with the S-8209B Series (With Discharge Cell-balance Function) for Series Multi-Cells

Figure 17 shows the example of protection circuit with the S-8209B Series (with discharge cell-balance function) for series multi-cells.

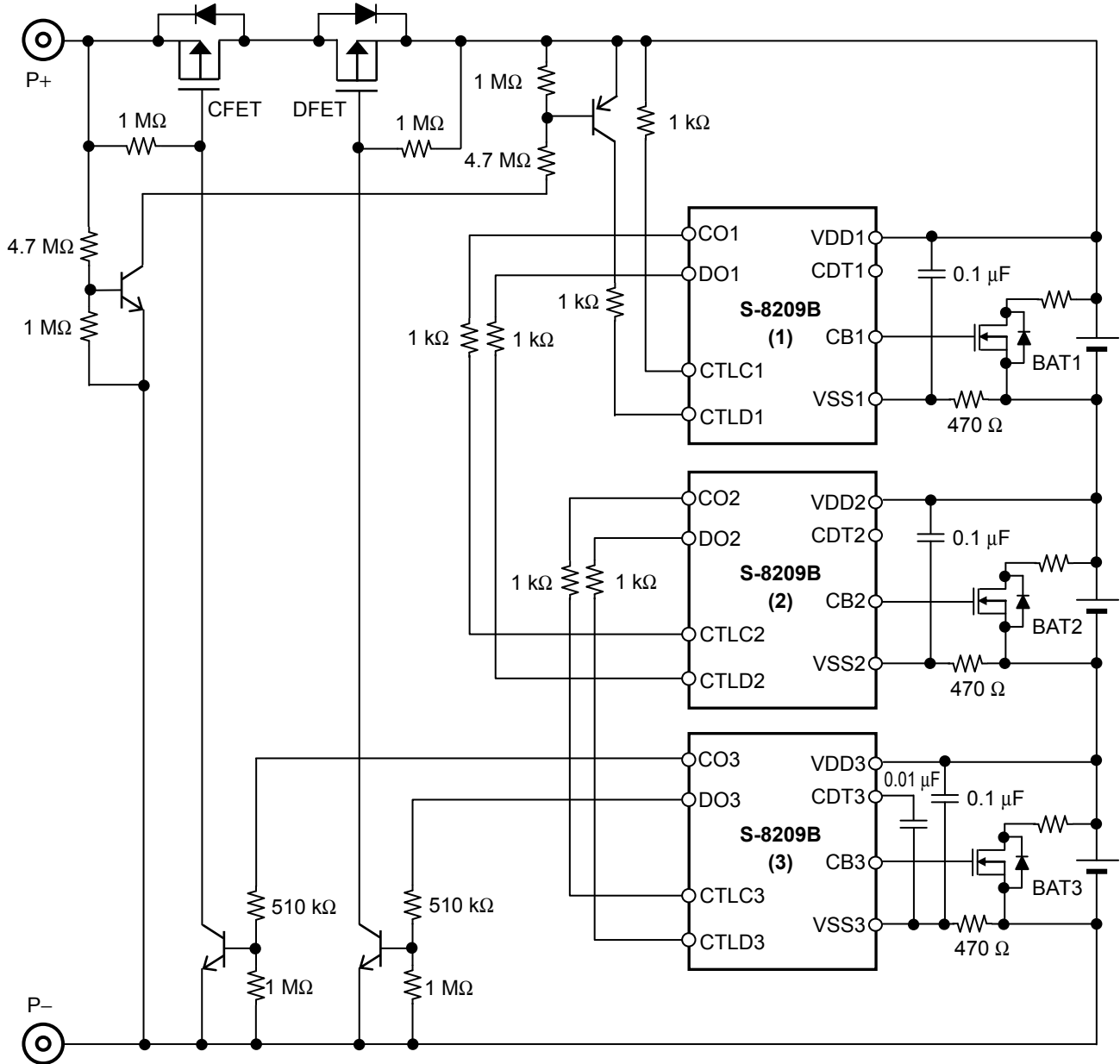

Figure 17

- Caution 1.** The above constants may be changed without notice.
2. The example of connection shown above and the constant do not guarantee proper operation. Perform thorough evaluation using the actual application to set the constant.

■ Precautions

- The application conditions for the input voltage, output voltage, and load current should not exceed the package power dissipation.
- Do not apply an electrostatic discharge to this IC that exceeds the performance ratings of the built-in electrostatic protection circuit.
- SII Semiconductor Corporation claims no responsibility for any and all disputes arising out of or in connection with any infringement by products including this IC of patents owned by a third party.

■ **Characteristics (Typical Data)**

1. Current consumption

1.1 I_{OPe} vs. T_a

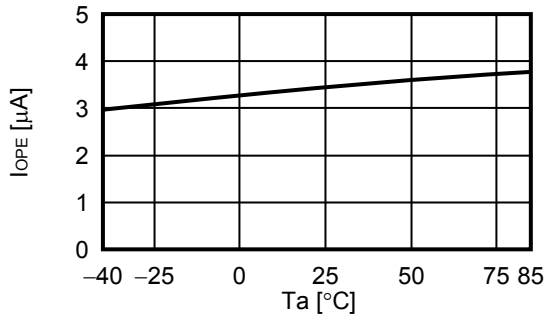

1.2 I_{OPe} vs. V_{Ds}

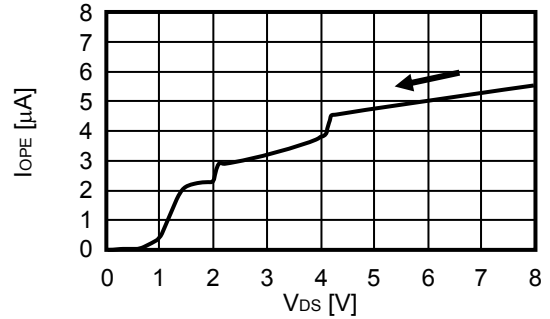

2. Overcharge detection / release voltages, Cell-balance detection / release voltages, Overdischarge detection / release voltages

2.1 V_{CU} vs. T_a

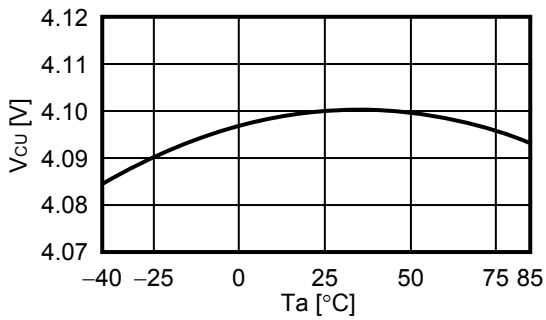

2.2 V_{CL} vs. T_a

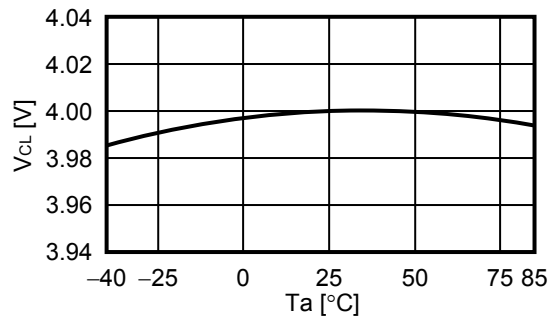

2.3 V_{BU} vs. T_a

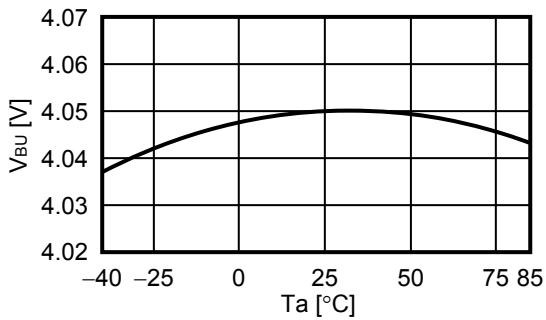

2.4 V_{BL} vs. T_a

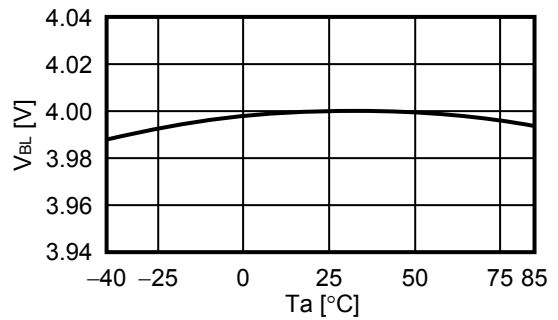

2.5 V_{DU} vs. T_a

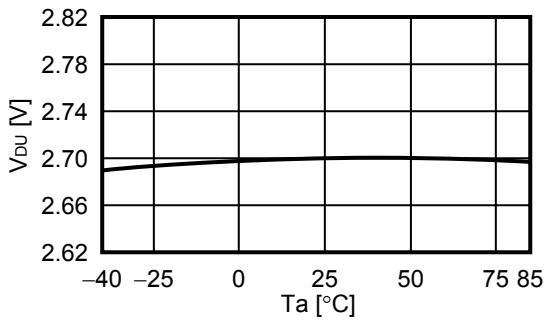

2.6 V_{DL} vs. T_a

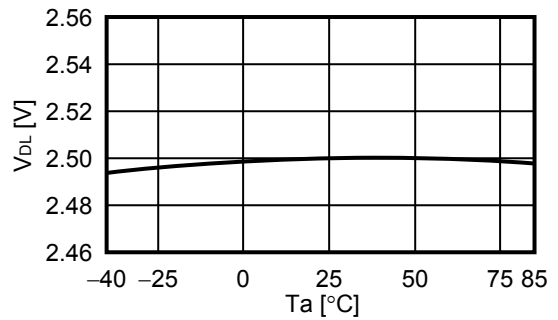

3. CO / DO / CB pin current

3.1 I_{COH} vs. V_{CO} (V_{DS} = 3.5 V)

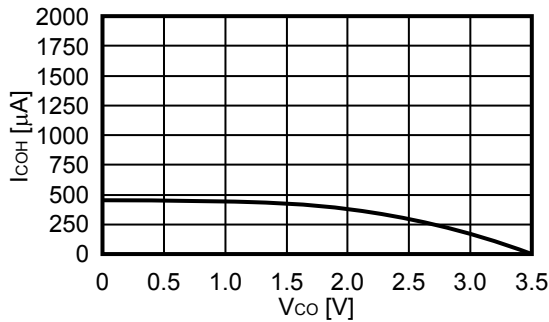

3.2 I_{DOH} vs. V_{DO} (V_{DS} = 3.5 V)

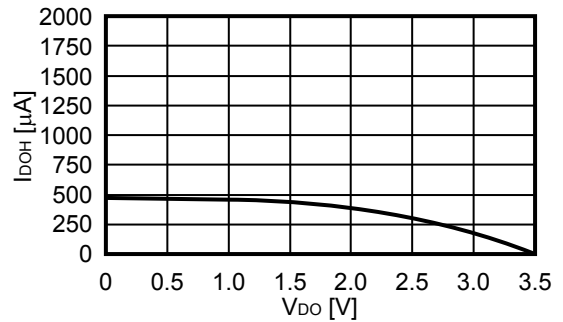

3.3 I_{CBH} vs. V_{CB} (V_{DS} = 4.5 V)

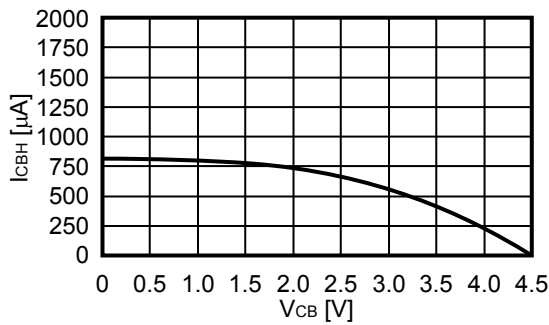

3.4 I_{CBL} vs. V_{CB} (V_{DS} = 3.5 V)

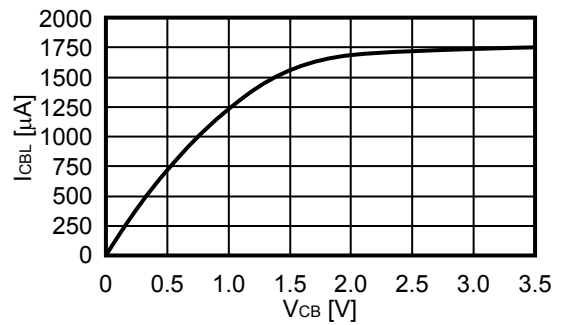

4. CTLC / CTLD pin current

4.1 I_{CTLCL} vs. Ta (V_{DS} = 3.5 V)

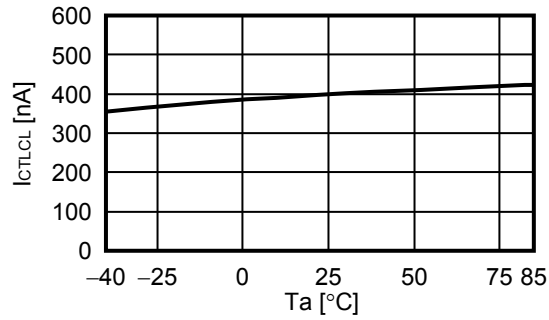

4.2 I_{CTLDL} vs. Ta (V_{DS} = 3.5 V)

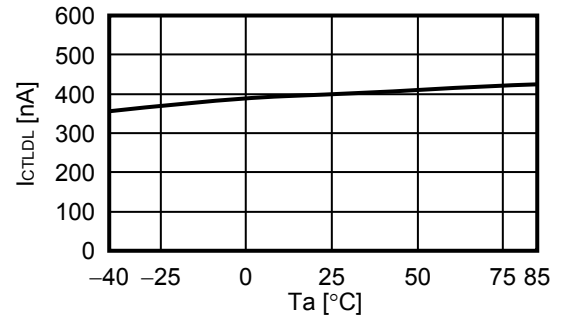

5. CDT pin resistance / CDT pin detection voltage

5.1 R_{CDT} vs. Ta

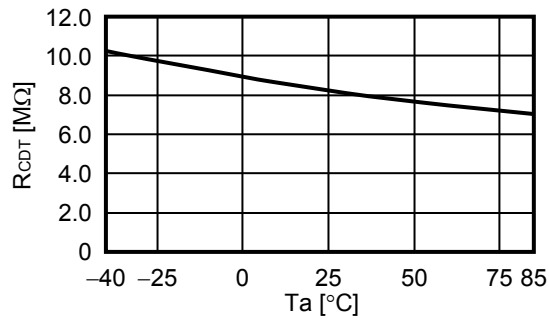

5.2 V_{CDDET} / V_{DS} vs. Ta

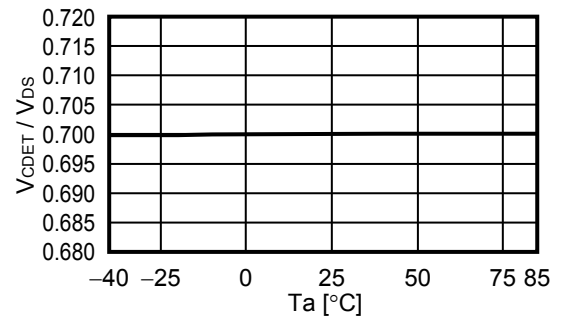

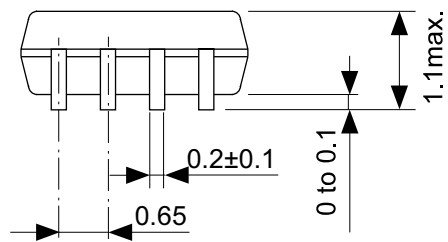
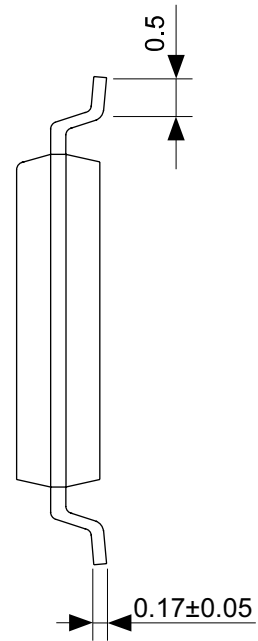
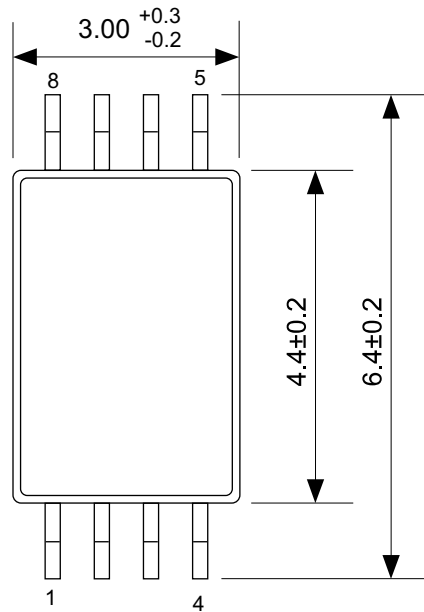

No. FT008-A-P-SD-1.1

TITLE	TSSOP8-E-PKG Dimensions
No.	FT008-A-P-SD-1.1
SCALE	
UNIT	mm
SII Semiconductor Corporation	

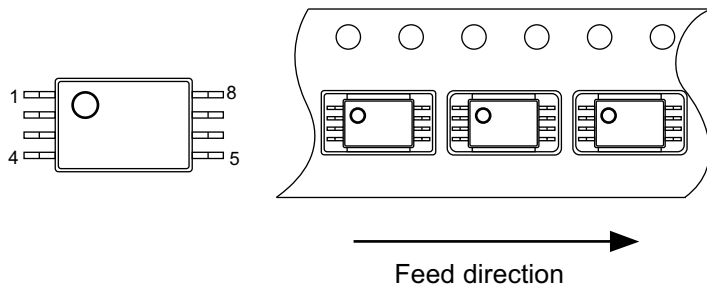
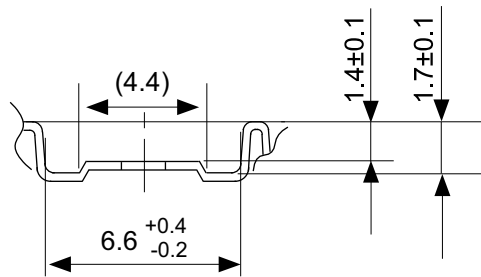
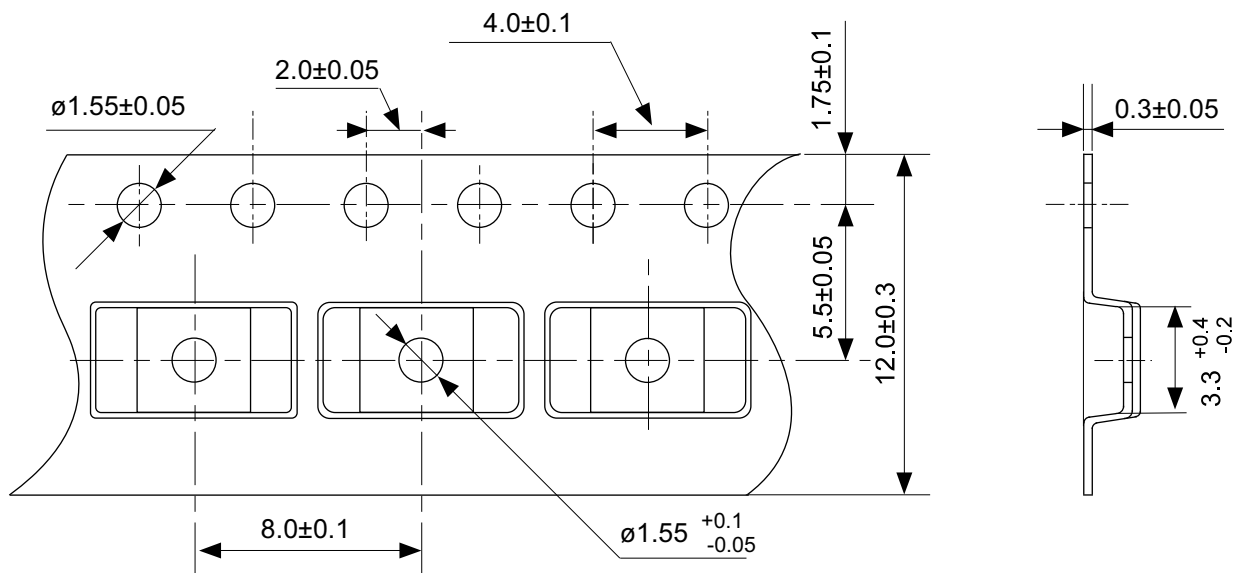

No. FT008-E-C-SD-1.0

TITLE	TSSOP8-E-Carrier Tape
No.	FT008-E-C-SD-1.0
SCALE	
UNIT	mm
SII Semiconductor Corporation	

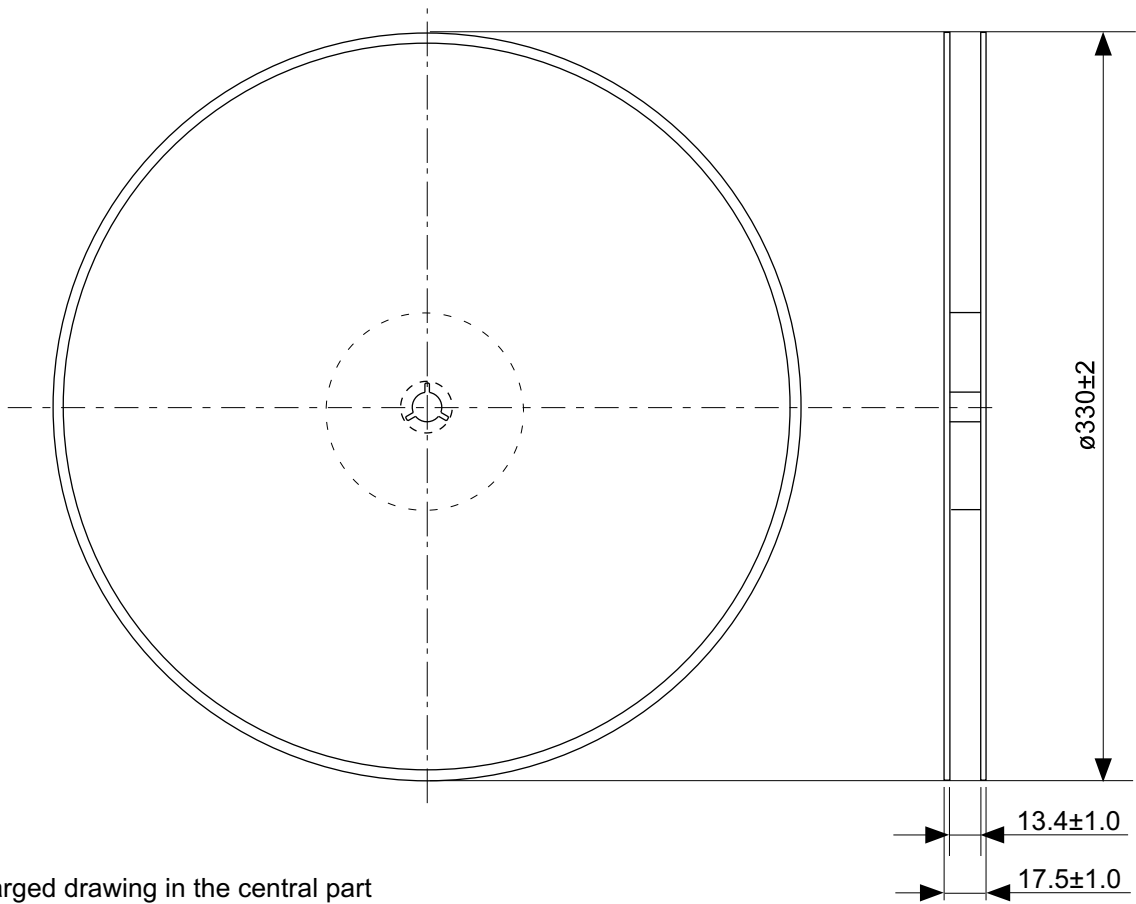

Enlarged drawing in the central part

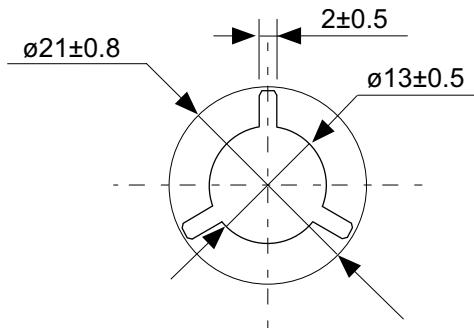

No. FT008-E-R-SD-1.0

TITLE	TSSOP8-E-Reel		
No.	FT008-E-R-SD-1.0		
SCALE		QTY.	3,000
UNIT	mm		
SII Semiconductor Corporation			

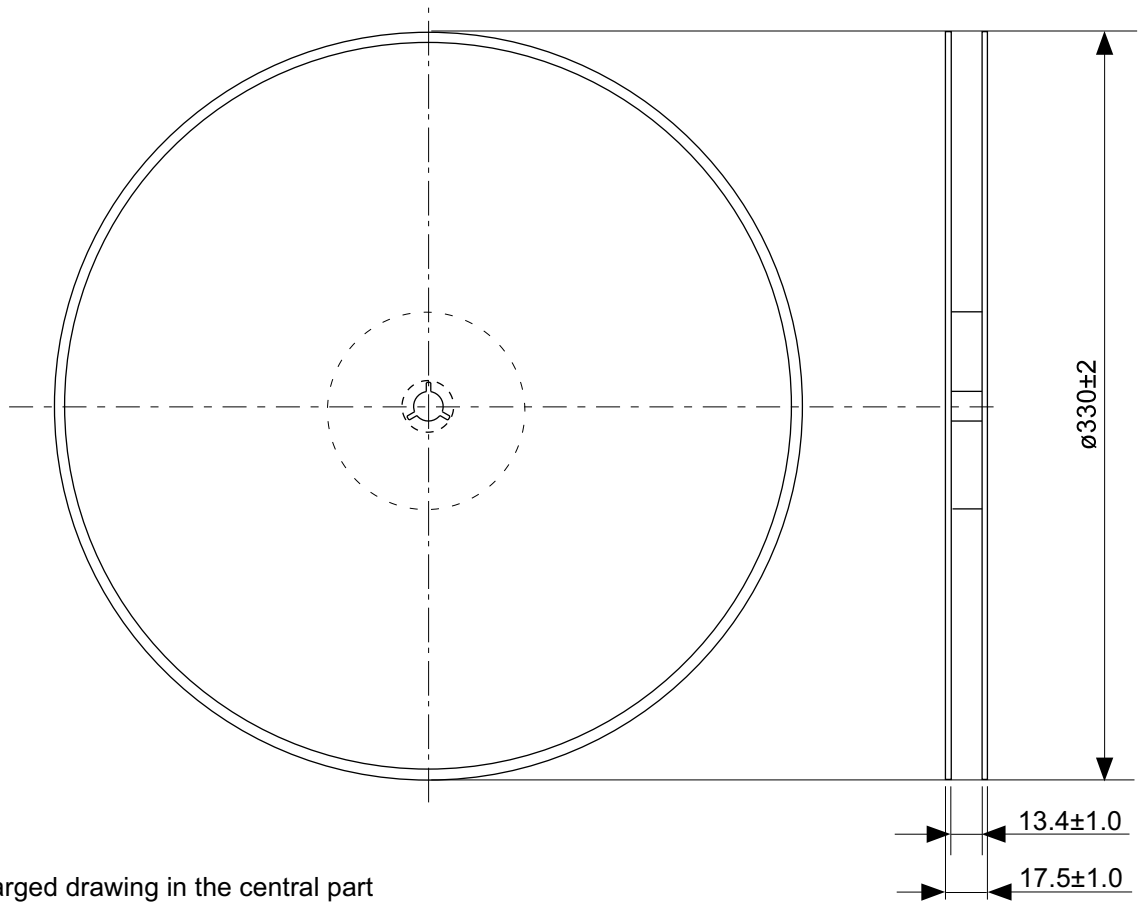

Enlarged drawing in the central part

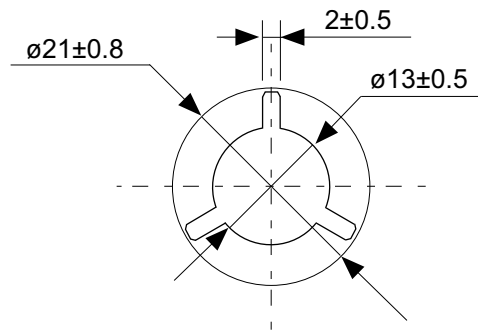

No. FT008-E-R-S1-1.0

TITLE	TSSOP8-E-Reel		
No.	FT008-E-R-S1-1.0		
SCALE		QTY.	4,000
UNIT	mm		
SII Semiconductor Corporation			

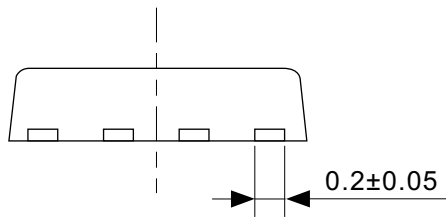
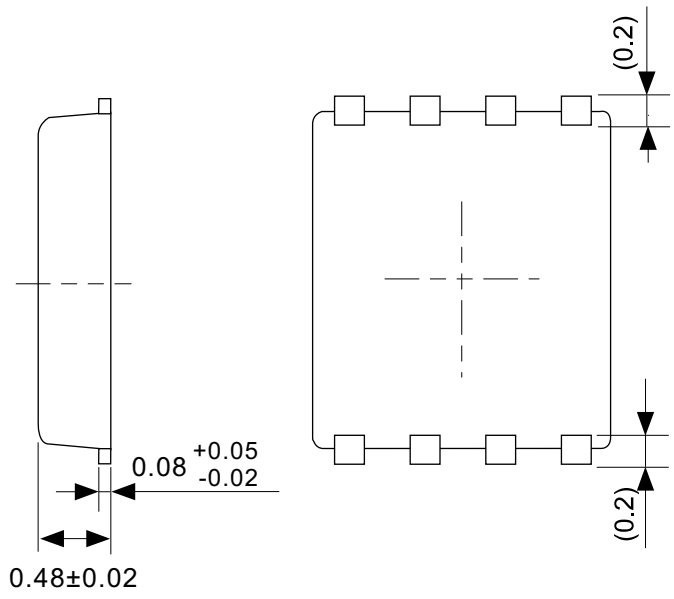
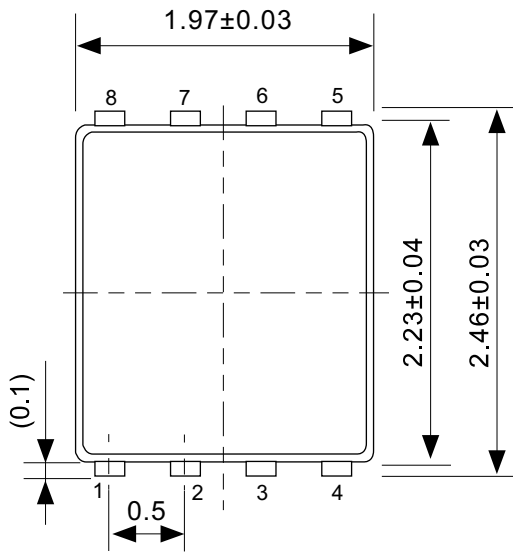

No. PH008-A-P-SD-2.0

TITLE	SNT-8A-A-PKG Dimensions
No.	PH008-A-P-SD-2.0
SCALE	
UNIT	mm
SII Semiconductor Corporation	

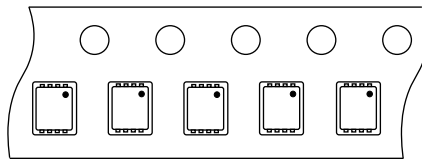
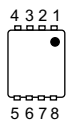
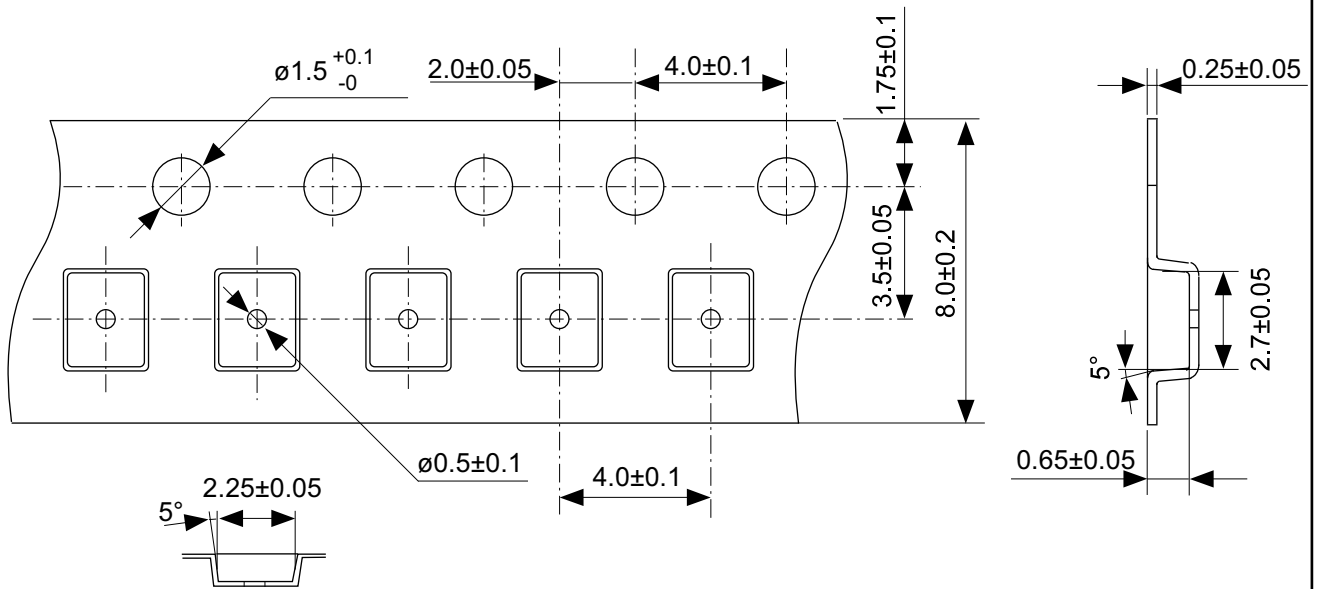

Feed direction

No. PH008-A-C-SD-1.0

TITLE	SNT-8A-A-Carrier Tape
No.	PH008-A-C-SD-1.0
SCALE	
UNIT	mm
SII Semiconductor Corporation	

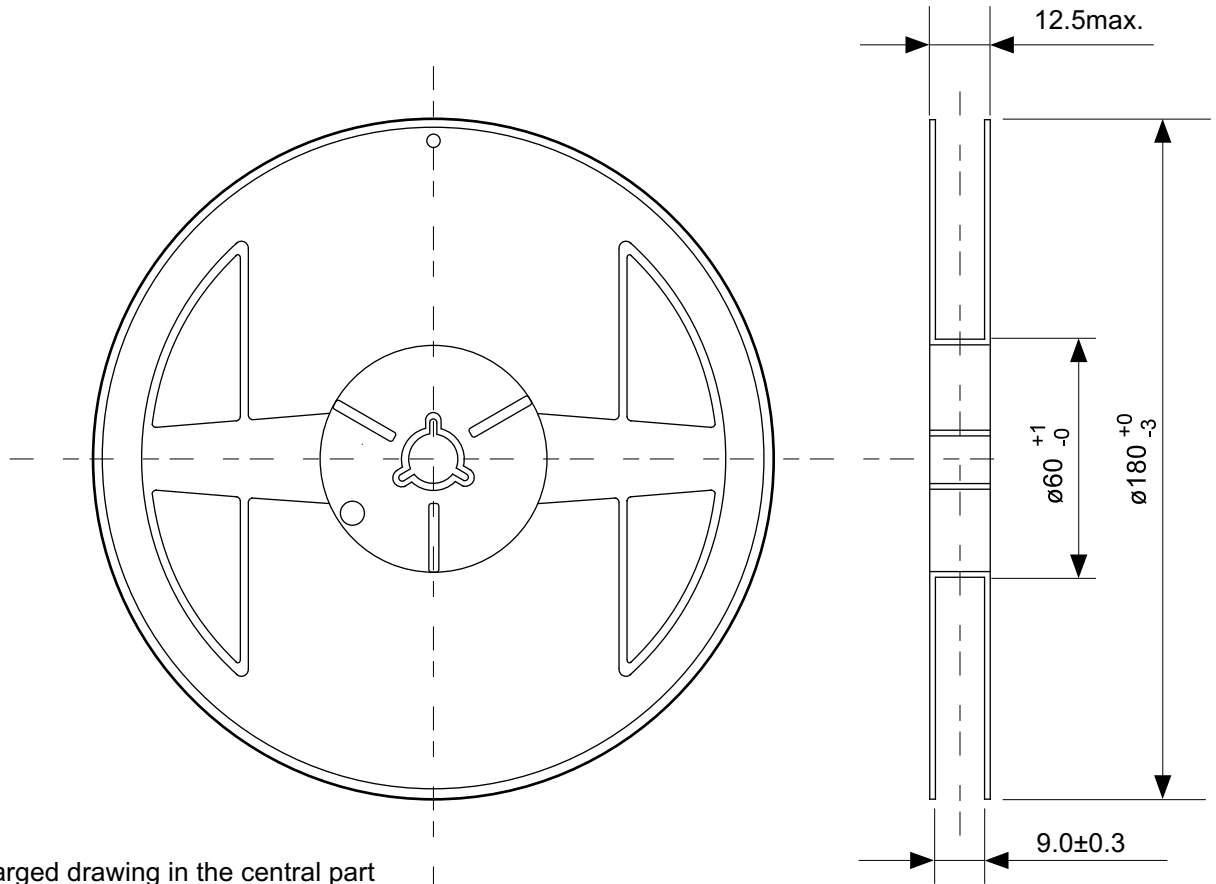

Enlarged drawing in the central part

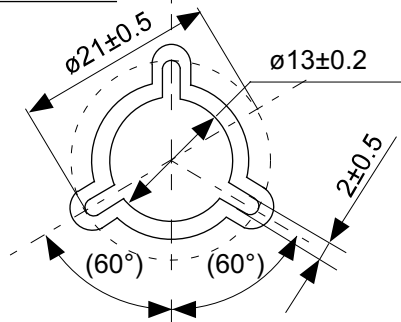

No. PH008-A-R-SD-1.0

TITLE	SNT-8A-A-Reel		
No.	PH008-A-R-SD-1.0		
SCALE		QTY.	5,000
UNIT	mm		
SII Semiconductor Corporation			

Disclaimers (Handling Precautions)

1. All the information described herein (product data, specifications, figures, tables, programs, algorithms and application circuit examples, etc.) is current as of publishing date of this document and is subject to change without notice.
2. The circuit examples and the usages described herein are for reference only, and do not guarantee the success of any specific mass-production design.
SII Semiconductor Corporation is not responsible for damages caused by the reasons other than the products or infringement of third-party intellectual property rights and any other rights due to the use of the information described herein.
3. SII Semiconductor Corporation is not responsible for damages caused by the incorrect information described herein.
4. Take care to use the products described herein within their specified ranges. Pay special attention to the absolute maximum ratings, operation voltage range and electrical characteristics, etc.
SII Semiconductor Corporation is not responsible for damages caused by failures and/or accidents, etc. that occur due to the use of products outside their specified ranges.
5. When using the products described herein, confirm their applications, and the laws and regulations of the region or country where they are used and verify suitability, safety and other factors for the intended use.
6. When exporting the products described herein, comply with the Foreign Exchange and Foreign Trade Act and all other export-related laws, and follow the required procedures.
7. The products described herein must not be used or provided (exported) for the purposes of the development of weapons of mass destruction or military use. SII Semiconductor Corporation is not responsible for any provision (export) to those whose purpose is to develop, manufacture, use or store nuclear, biological or chemical weapons, missiles, or other military use.
8. The products described herein are not designed to be used as part of any device or equipment that may affect the human body, human life, or assets (such as medical equipment, disaster prevention systems, security systems, combustion control systems, infrastructure control systems, vehicle equipment, traffic systems, in-vehicle equipment, aviation equipment, aerospace equipment, and nuclear-related equipment), excluding when specified for in-vehicle use or other uses. Do not use those products without the prior written permission of SII Semiconductor Corporation. Especially, the products described herein cannot be used for life support devices, devices implanted in the human body and devices that directly affect human life, etc.
Prior consultation with our sales office is required when considering the above uses.
SII Semiconductor Corporation is not responsible for damages caused by unauthorized or unspecified use of our products.
9. Semiconductor products may fail or malfunction with some probability.
The user of these products should therefore take responsibility to give thorough consideration to safety design including redundancy, fire spread prevention measures, and malfunction prevention to prevent accidents causing injury or death, fires and social damage, etc. that may ensue from the products' failure or malfunction.
The entire system must be sufficiently evaluated and applied on customer's own responsibility.
10. The products described herein are not designed to be radiation-proof. The necessary radiation measures should be taken in the product design by the customer depending on the intended use.
11. The products described herein do not affect human health under normal use. However, they contain chemical substances and heavy metals and should therefore not be put in the mouth. The fracture surfaces of wafers and chips may be sharp. Take care when handling these with the bare hands to prevent injuries, etc.
12. When disposing of the products described herein, comply with the laws and ordinances of the country or region where they are used.
13. The information described herein contains copyright information and know-how of SII Semiconductor Corporation.
The information described herein does not convey any license under any intellectual property rights or any other rights belonging to SII Semiconductor Corporation or a third party. Reproduction or copying of the information described herein for the purpose of disclosing it to a third-party without the express permission of SII Semiconductor Corporation is strictly prohibited.
14. For more details on the information described herein, contact our sales office.

1.0-2016.01



Mouser Electronics

Authorized Distributor

Click to View Pricing, Inventory, Delivery & Lifecycle Information:

Seiko Instruments:

[S-8209BAA-T8T1S](#) [S-8209BAA-T8T1G](#) [S-8209AAZ-I8T1U](#) [S-8209AAA-I8T1U](#) [S-8209AAK-I8T1U](#) [S-8209AAG-I8T1U](#) [S-8209AAS-I8T1U](#) [S-8209AAH-I8T1U](#) [S-8209AAF-I8T1U](#) [S-8209AAL-I8T1U](#) [S-8209ABF-I8T1U](#) [S-8209AAC-I8T1U](#) [S-8209AAD-I8T1U](#) [S-8209AAU-I8T1U](#) [S-8209AAJ-I8T1U](#) [S-8209AAB-I8T1U](#) [S-8209ABE-I8T1U](#) [S-8209ABA-I8T1U](#) [S-8209ABG-I8T1U](#) [S-8209AAT-I8T1U](#) [S-8209AAX-I8T1U](#) [S-8209BAA-I8T1U](#)



Стандарт Электрон Связь

Мы молодая и активно развивающаяся компания в области поставок электронных компонентов. Мы поставляем электронные компоненты отечественного и импортного производства напрямую от производителей и с крупнейших складов мира.

Благодаря сотрудничеству с мировыми поставщиками мы осуществляем комплексные и плановые поставки широчайшего спектра электронных компонентов.

Собственная эффективная логистика и склад в обеспечивает надежную поставку продукции в точно указанные сроки по всей России.

Мы осуществляем техническую поддержку нашим клиентам и предпродажную проверку качества продукции. На все поставляемые продукты мы предоставляем гарантию .

Осуществляем поставки продукции под контролем ВП МО РФ на предприятия военно-промышленного комплекса России , а также работаем в рамках 275 ФЗ с открытием отдельных счетов в уполномоченном банке. Система менеджмента качества компании соответствует требованиям ГОСТ ISO 9001.

Минимальные сроки поставки, гибкие цены, неограниченный ассортимент и индивидуальный подход к клиентам являются основой для выстраивания долгосрочного и эффективного сотрудничества с предприятиями радиоэлектронной промышленности, предприятиями ВПК и научно-исследовательскими институтами России.

С нами вы становитесь еще успешнее!

Наши контакты:

Телефон: +7 812 627 14 35

Электронная почта: sales@st-electron.ru

Адрес: 198099, Санкт-Петербург,
Промышленная ул, дом № 19, литера Н,
помещение 100-Н Офис 331