

SX8724CEVK USER GUIDE

Evaluation Kit for SX8724C Data Acquisition System

Description

The SX8724CEVK is a platform for SX8724C evaluation and sensing application prototyping. It consists of a single board with the ZoomingADC device interfaced to the computer through a USB gateway.

All SX8724C I/Os are available and placed on breakout pads for easy access. The tool is intended to be the interface between the sensor and the PC in order to ease the handling of the SX8724C.

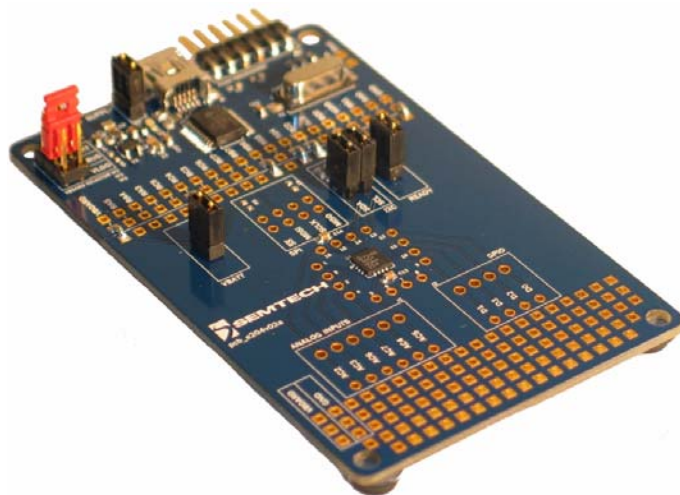

Equipment Needed

- PC with Windows XP or a latest version
- Powered USB 2.0 port

Ordering Informations

EVK Part Number	Function
SX8724CEVK	SX8724C (I2C) Evaluation

Features

- Evaluation Board
 - Directly connects most types of sensors
 - Extended temperature range from -40 to 125°C
 - 2.4V to 5.5V operation
 - Supply from 5V USB, externally or regulated 3.3V
 - USB interface with gateway to the SX8724C
 - On board master MCU with flash memory, access to all IO
 - Prototyping area
 - I/Os, board supplies and grounds placed on pads
- Graphical User Interface
 - Easy settings through registers and controls
 - System and device performance analysis tool
 - Save and load configurations
 - Log to file
- SX8724C ZoomingADC System Evaluation
 - Up to 16-bit differential data acquisition
 - Programmable gain: (1/12 to 1000)
 - Sensor offset compensation up to 15 times full scale of input signal
 - 3 differential or 6 single-ended signal inputs
 - Programmable Resolution versus Speed versus Supply current
 - External reference input voltage
 - Internal reference output
 - Digital outputs to bias sensors
 - Low-power (250 uA for 16b @ 500 S/s)
- Digital Interface
 - Access to I2C signal
 - ADC conversion ready
 - 4 GPIO
 - Possibility to chain boards on the same bus
- Application Examples in this User Guide
 - Interfacing your first pressure sensor

TABLE OF CONTENT

Section	Page
GETTING STARTED	4
1 Introduction	4
2 Evaluation Kit Contents	4
3 Board Overview	5
4 Software Installation	6
4.1 About Microsoft .NET Framework	7
5 Board Connection and Drivers Installation (first time)	8
HARDWARE DESCRIPTION	9
6 Board Schematic	9
7 User Interfaces	10
7.1 Prototyping Area	11
8 Power Supply	12
8.1 Power Sources Specifications	12
8.2 Power Supply Selection	13
9 USB Interface	14
9.1 Gateway to SX8724C	14
10 EVK Bill of Materials List	16
11 Board Physical Dimensions	18
11.1 Errata Note	18
GRAPHICAL USER INTERFACE	19
12 Software Tool Overview	19
13 Main Window	20
13.1 Menu Tool Bar	20
13.2 Window Tool Bar	22
13.3 Status Bar	23
13.4 ZoomingADC controls	24
13.5 Voltage Control	28
13.6 Estimated Device Performances	28
13.7 Display Chart	30
13.8 Log Data to File	31
14 ZoomingADC Data Display Window	32
14.1 ZoomingADC data display panel	32
14.2 Histogram Panel - Noise Analysis	33
14.3 Measured System Performances	33
15 Registers Display Window	35
16 Verification Mode Window	35
APPLICATION EXAMPLES	36
17 Interfacing your first pressure sensor	36
17.1 Introduction	36
17.2 Pressure Sensor	36
17.3 Using the Evaluation Board and the GUI	40

TABLE OF CONTENT

Section		Page
17.4	Reading the sensor using the GUI	41
17.5	Reference Voltage Selection.	41
17.6	ZoomingADC™ Configuration.	43
17.7	ADC Configuration	46
17.8	Noise Cancellation	48
17.9	LSB Equivalence.	49
17.10	ZoomingADC™ Benefits.	50

GETTING STARTED

1 Introduction

This section describes a typical configuration for operating the evaluation board of the SX8724C with ZoomingADC.

The SX8724C is a signal conditioner based on Semtech's ultra low power ZoomingADC™ technology. It directly connects most types of miniature sensors with a general purpose microcontroller.

The SX8724CEVK is a USB based evaluation tool designed to allow simple and easy evaluation of the suitability of the SX8724C device for a given application.

The analog input signal can be entered either in differential or single ended. Refer to the datasheet for the impact of driving an analog input in single or in differential.

2 Evaluation Kit Contents

The SX8724CEVK evaluation kit consists of:

- a "Read me first" sheet
- an Evaluation Board
- one USB cable
- a CDROM containing:
 - Software Installer including *MS .NET framework 3.5* and USB drivers
 - SX8724CEVK User Guide (this document)

3 Board Overview

The picture below describes the main zones and functions accessible on the SX8724CEVK

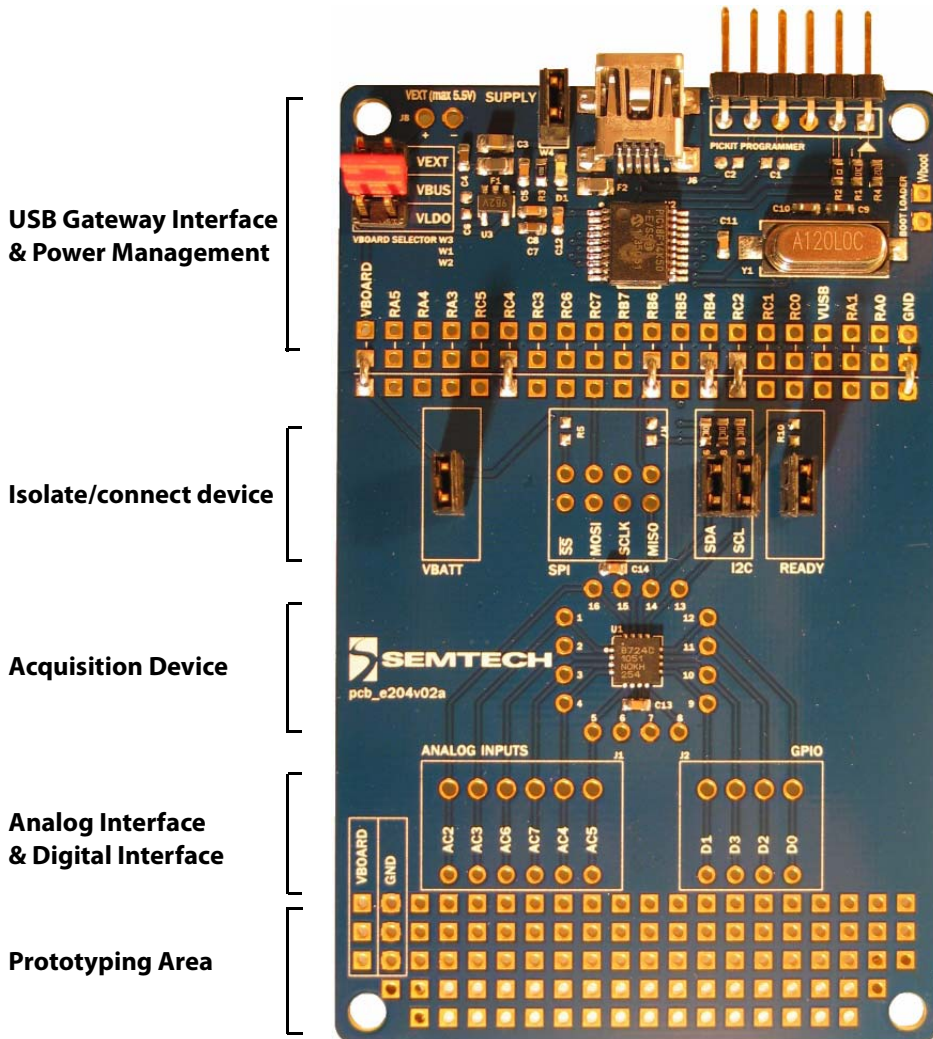

Figure 1. SX8724CEVK Board Overview

4 Software Installation

If the evaluation kit is supplied with an insert sheet, follow the instruction on the insert sheet. The latest software revision can be downloaded on Semtech website.

1. Put the CDROM in your computer and browse the contents of the CD, open the *SX8724xEvaluationKitSetup.exe* file manually. It can be found in the root of the CD-ROM. Click on *Next>* to start the installation



Figure 2. Installation Screen

2. Choose the installation directory. The software must be installed on a local directory. Click on *Next>* to confirm the path.

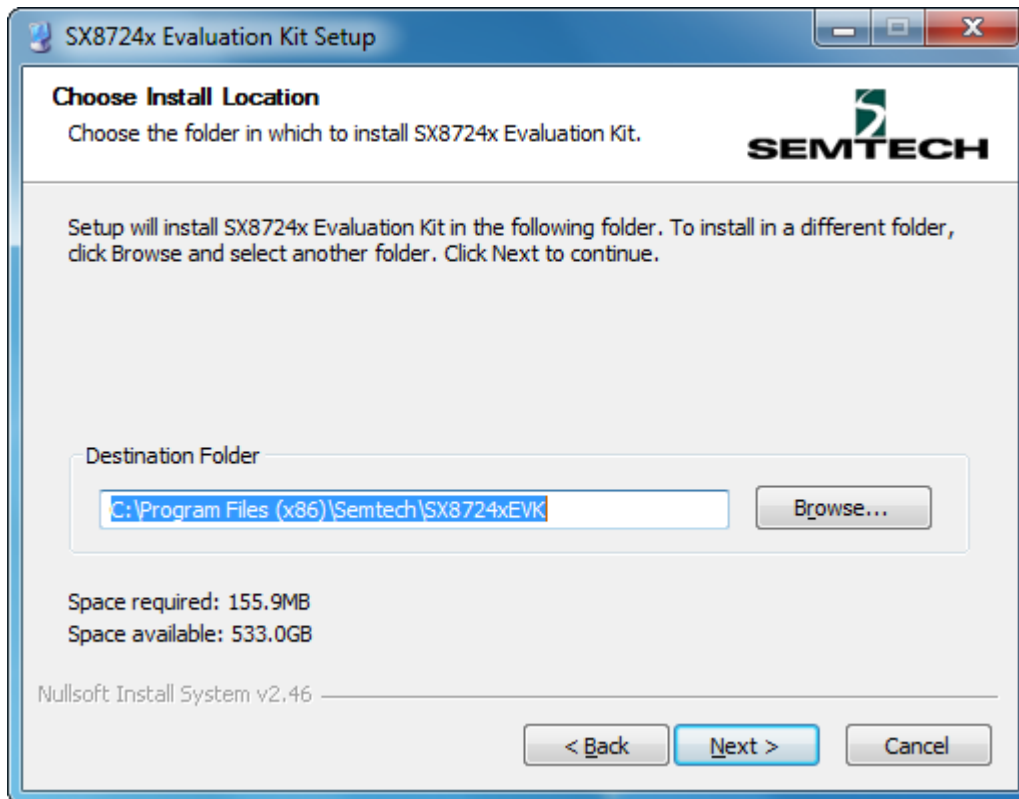

Figure 3. Software Install Location

3. Follow the on-screen installation guidelines until the process is completed. Please note that *.NET Framework 3.5* and the PIC USB driver will be automatically installed if not detected on your computer. (Administrator rights may be needed).

4. The GUI software and *.Net Framework* are now installed on your computer.

4.1 About Microsoft .NET Framework

The *Microsoft .NET Framework 3.5* is required to run the software. The software installer will install the it automatically if not present on your computer.

Details and installation information about the *.NET Framework* are available on Microsoft web site (<http://www.microsoft.com>). Then go to the Download section.

There are multiple versions of the *.NET Framework* available from Microsoft, and they can be installed side-by-side on the same computer. Contact your system administrator for more details.

5 Board Connection and Drivers Installation (first time)

1. Connect the board to the PC with the USB interface. The board is powered via the USB and will be detected as new USB peripheral. Choose the *"Install the software automatically (Recommended)"* option and click on the *Next>* button.
2. Windows will search for the associated driver and install the board as new peripheral.
3. Follow the on-screen installation guidelines until the process is completed. Driver compatibility screens may appear during the installation procedure. Validate always by clicking the *"Continue Anyway button"*:
4. The drivers are now installed. The board and its dedicated software are ready to be used. Launch *SX8724xEVK* software from the Windows Start menu.

HARDWARE DESCRIPTION

6 Board Schematic

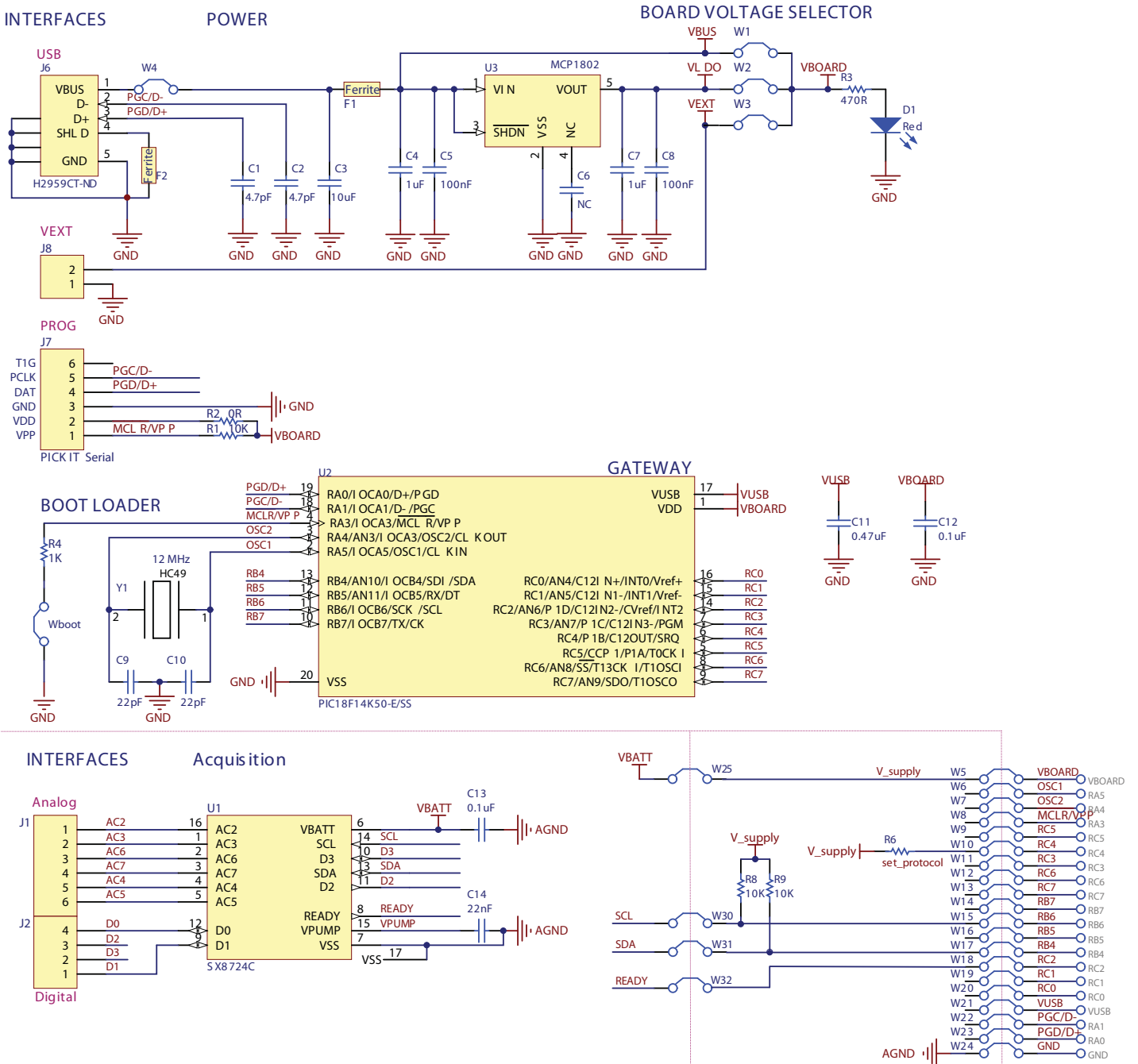

7 User Interfaces

The analog interface gives access to the ZoomingADC inputs. The digital interface gives access to the GPIO pins, the PC gateway connections and the power supplies. The analog and digital connections are available on single row 2.54mm connectors and on the bare PCB next to the prototyping area.

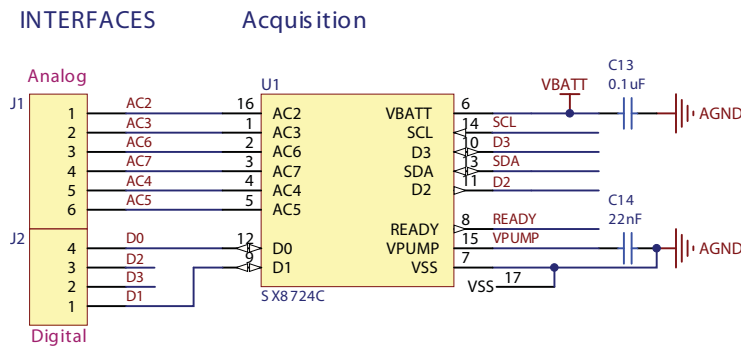

Figure 4. Analog Interface Schematic

The connections points are available for industrial PCB terminal blocks and on the bare PCB next to the SX8724C

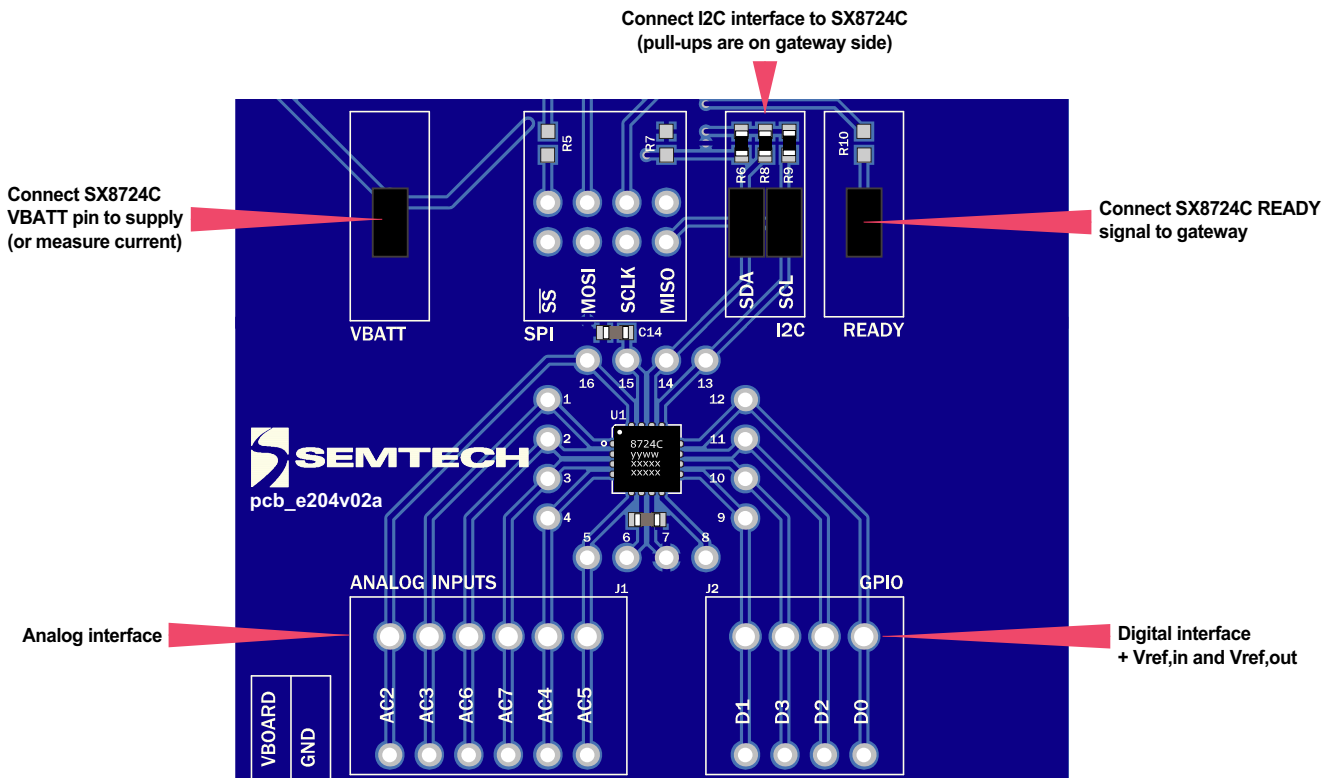

Figure 5. SX8724C Interface on the Board

7.1 Prototyping Area

Using the prototyping area, one can set its own application only using the SX8724C and bypassing the onboard gateway.

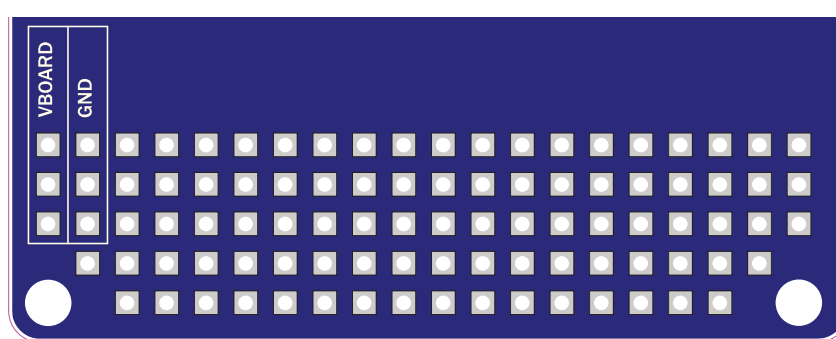

Figure 6. Prototyping Area

8 Power Supply

The board provides different power supply voltage possibilities; the following paragraphs describe how to configure and use them.

8.1 Power Sources Specifications

The board can be powered through three different sources:

1. VBUS: USB power coming from the PC.
2. VLDO: 3.3V Regulated voltage.
3. VEXT: External source applied on VEXT interface.

Input analog voltages specified in the device datasheet.

Table 1. Power Sources Specifications

Voltage range	Min	Typ	Max	Unit	Comment
VBUS	4.5	5	5.5	V	DC, Unregulated
VLDO ¹		3.3		V	DC, Regulated
VEXT	2.4	-	5.5	V	DC, Unregulated ²
Board current driving capability					
	-		100	mA	

1. Temperature range from -40 to 85°C
2. External power supply

8.2 Power Supply Selection

Available supply voltages vs. selected power source is described below.

IMPORTANT NOTICE

- DO NEVER CONNECT VEXT JUMPER IF EXTERNAL VOLTAGE IS HIGHER THAN 5.5VDC.
- CONNECT ONLY ONE JUMPER ON THIS SELECTOR

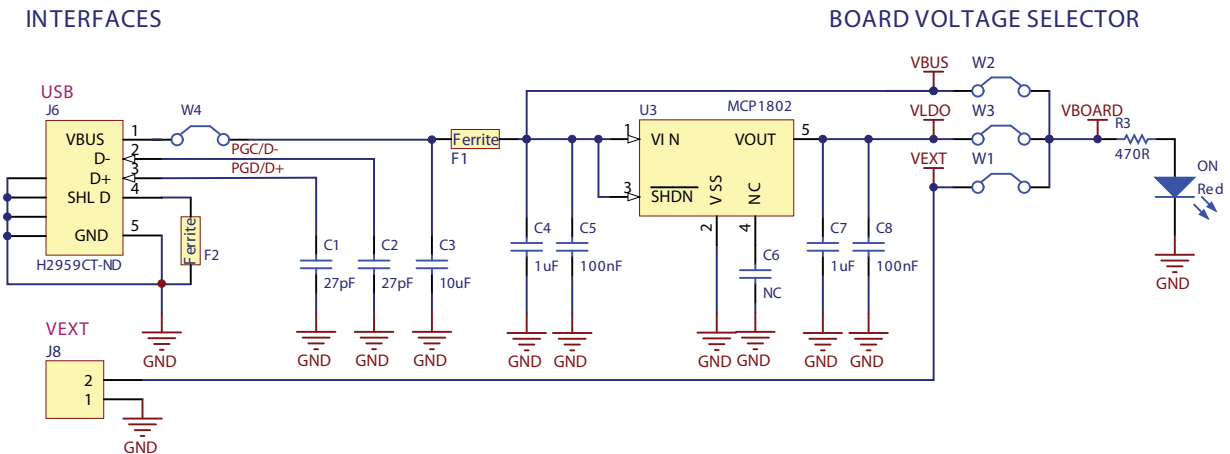

Figure 7. Power Supply Schematic

The picture below shows the selector. User should place the jumper on the desired SX8724C supply voltage value.

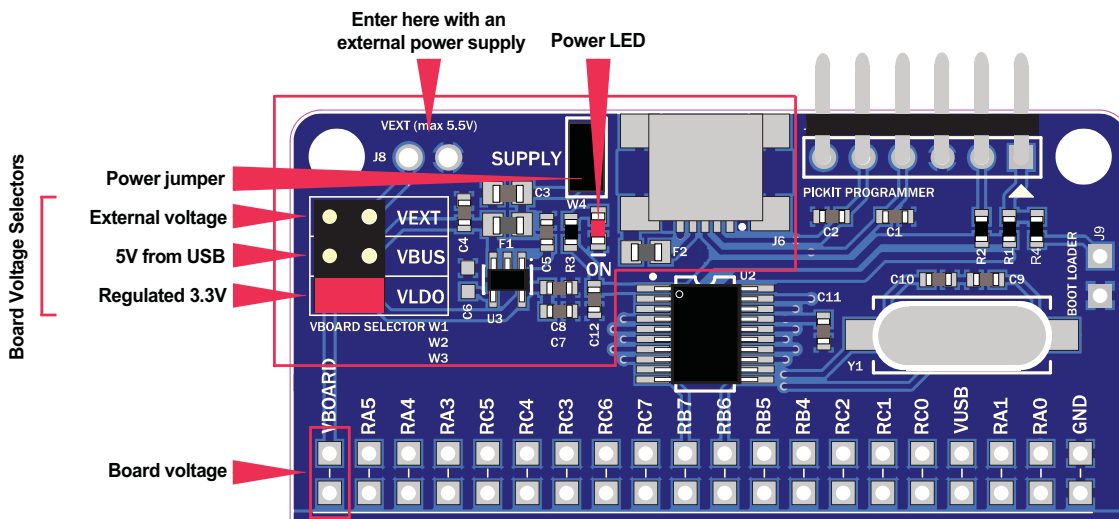

Figure 8. SX8724CEVK Power Supply Selector

9 USB Interface

9.1 Gateway to SX8724C

The USB gateway is a complete interface to drive the SX8724C on the board. The knowledge, implementation or modification of this gateway is not required for evaluation.

This interface is used to communicate with the GUI, but can also enable automation with external processes such as Python, MATLAB, and LabVIEW.

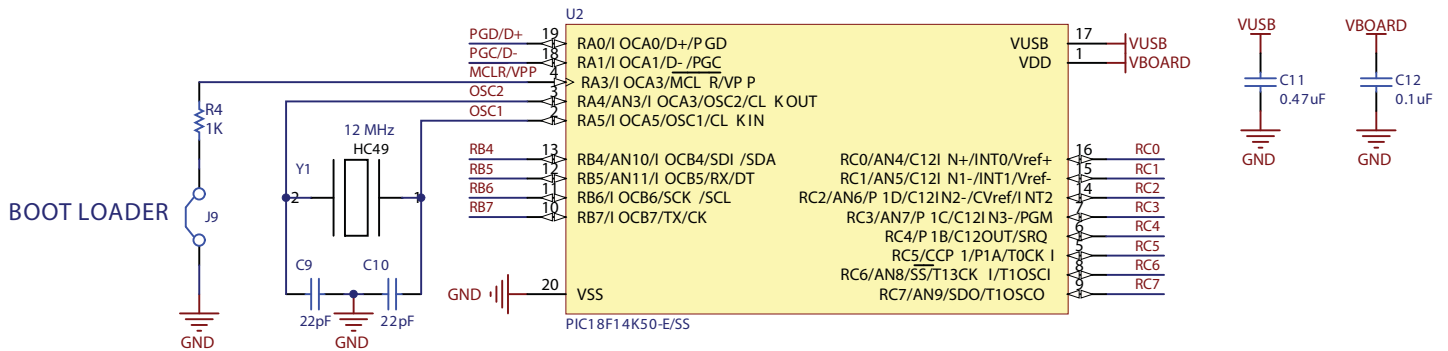

Figure 9. PIC Gateway Schematic

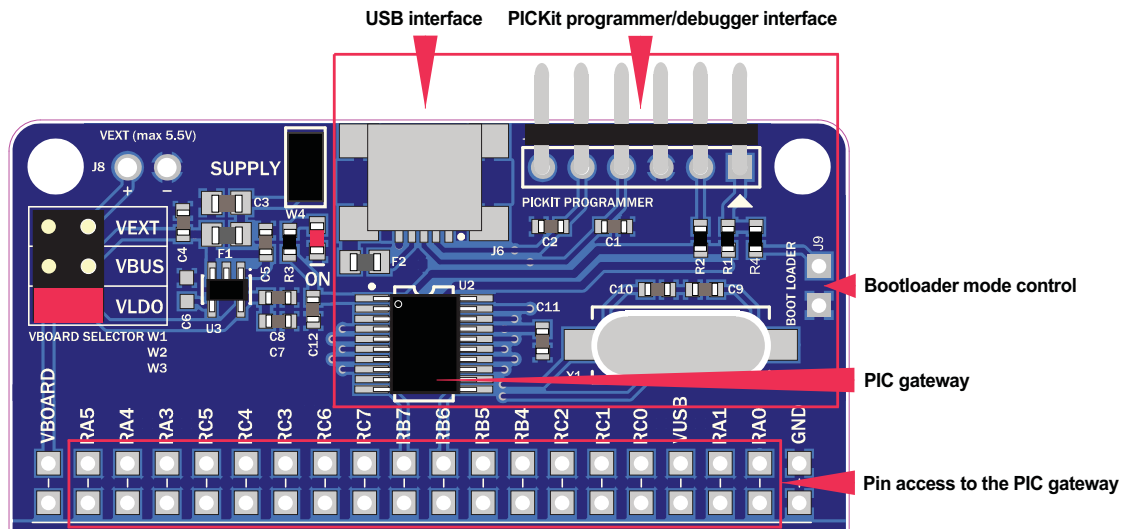

Figure 10. PIC Gateway on the Board

9.1.1 Bootloader Mode

The BOOT LOADER (J9) jumper allows the user to set the onboard PIC18F14K50 in bootloader mode and to program it. One can then update the gateway with the latest driver from Semtech website or set its own solution¹ using the I2C interface (see **7.1. Prototyping Area**).

By default, the jumper is not connected.

To enter in bootloader mode, shortcut the BOOT LOADER (J9) jumper and restart the PIC by unplug-plug the SUPPLY jumper or disconnect-connect the USB cable (see **Figure 10 on page 14**).

9.1.2 PICkit Programming Interface

This interface is used to program the board with a Microchip PICkit 3 Programmer/Debugger.

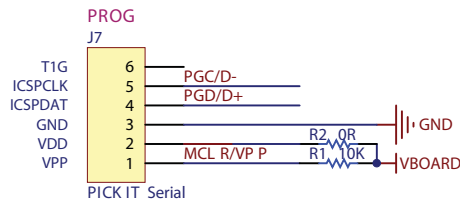

Figure 11. PICKIT Programmer Interface

1. Semtech does not provide support for modified Gateway software other than the official releases available on the website.

10 EVK Bill of Materials List

Table 2. SX8724CEVK Bill of Material

Ref	Val	Package	Description	Manufacturer	Part#
IC					
U1		MLPQ-16 4x4	SX8724C acquisition system	SEMTECH	SX8724CWLTD
U2		SSOP-20, 6.5mm pitch	PIC Gateway	Microchip	PIC18F14K50-E/SS
U3		SOT23-5	3.3V REG LDO 300MA	Microchip	MCP1802T-3302I/OT
Connectors					
J6		Surface Mount, Right Angle, Horizontal	Connector mini USB2.0	Interconnects	UX60-MB-5ST
J7		Through Hole, Right Angle	Header BRKWAY .100 6POS R/A	Tyco Electronics	9-103325-0-06
Crystal					
Y1		Surface Mount, HC49/US	Crystal 12.00000 MHZ 18pF SMD	Abracon Corporation	ABLS-12.000MHZ-K4T
Jumpers/selectors					
W1, W2, W3,		Through Hole, 2.54mm	3x2 header + 1x RED jumper		
W4, W25, W32		Through Hole, 2.54mm	3x 1x2 headers + 3x BLACK jumper		
W30, W31		Through Hole, 2.54mm	2x2 header + 2x BLACK jumper		
Ferrites Bead					
F1, F2		SMD 0805	Ferrite 1.5A 40 Ohm	Steward	PZ2012D400-3R0TF
Resistors					
R1, R5, R6	10K	SMD 0603			
R2	0R	SMD 0603	PICKIT prog		
R3	470R	SMD 0603	LED current limiting resistor		
R4	1K	SMD 0603	Protection for Bootloader bypass		
Capacitors					
C1, C2,	47pF	SMD 0603			
C3	10uF	SMD 0805			
C4, C7	1uF	SMD 0603			

Table 2. SX8724CEVK Bill of Material

Ref	Val	Package	Description	Manufacturer	Part#
C5, C8, C12, C13	100nF	SMD 0603			
C9, C10	22pF	SMD 0603			
C11	47nF	SMD 0603			
C14	22nF	SMD 0603			

11 Board Physical Dimensions

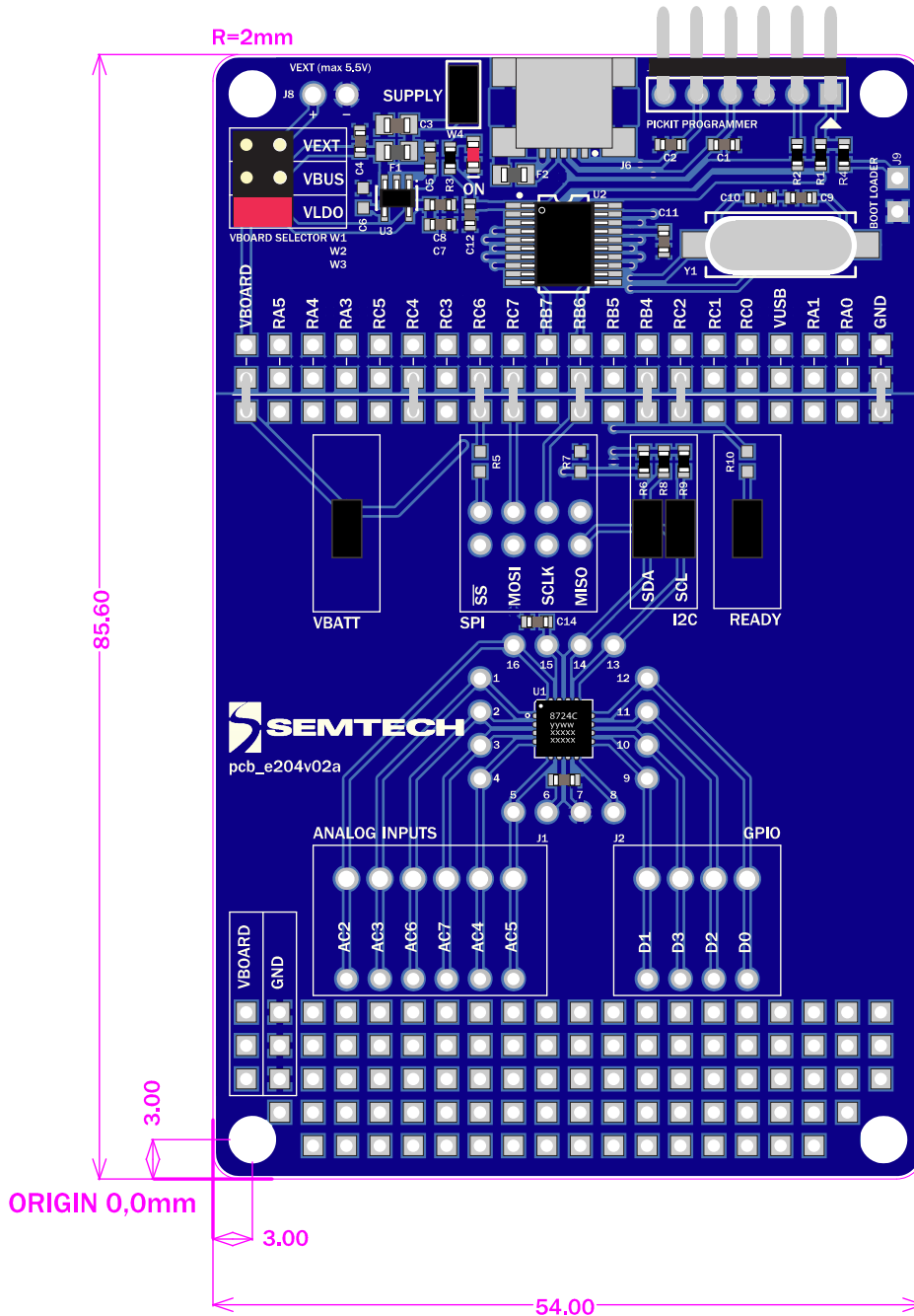

Figure 12. SX8724CEVK Board Overview

11.1 Errata Note

Boards with the PCB reference pcb_e204v02a have the MOSI and SCLK marking inverted.

GRAPHICAL USER INTERFACE

12 Software Tool Overview

The SX8724CEVK includes a graphical user interface (GUI) that provides simplified access to all key registers on the board. It uses intuitive controls and popup menus to write settings from the hardware.

This GUI takes high level input from the user and computes the required low level register values. With the GUI, the user is not required to compute complicated equations to determine which values must be written for board operation. In addition, the GUI simplifies analog interfacing by providing controls that simplify alignment of analog functions.

The figure below illustrates the SX8724xEVK graphical user interface (GUI). Each of the numbered captions corresponds to a proceeding chapter within the sections which correspond to the description of that GUI feature:

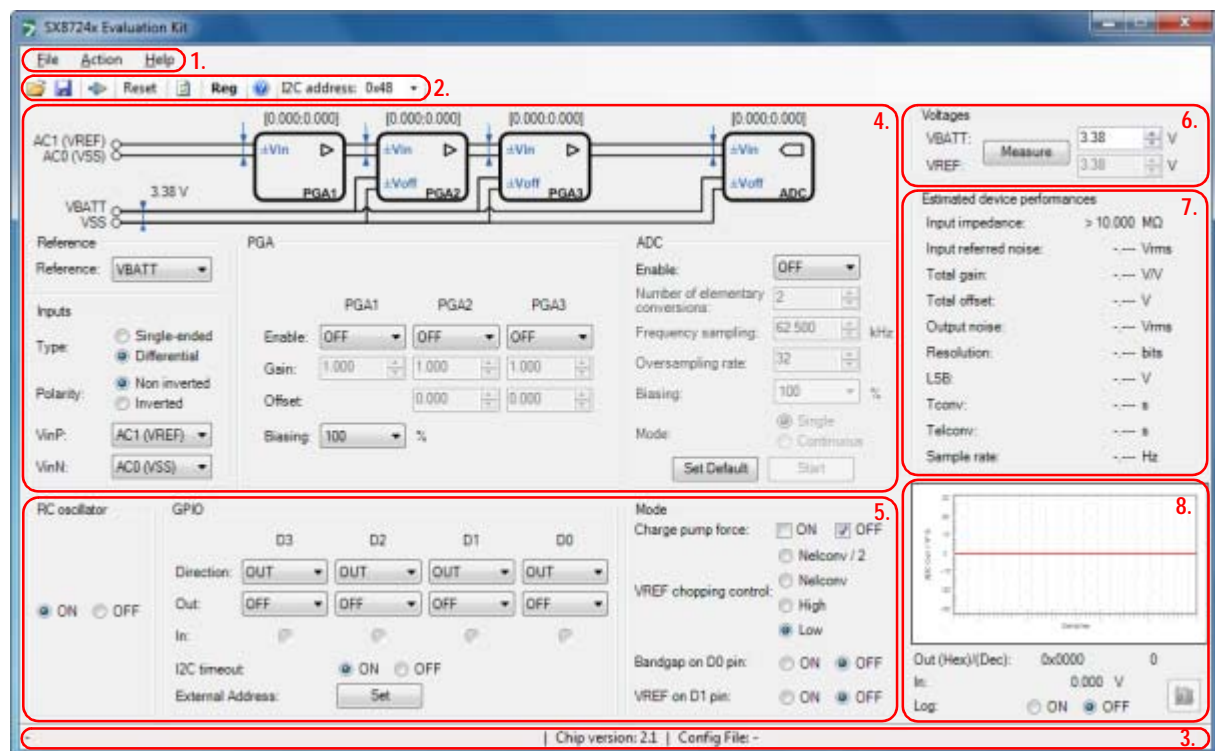

Figure 13. SX8724xEVK GUI Overview

1. see section **13.1. Menu Tool Bar** in **page 20**
2. see section **13.2. Window Tool Bar** in **page 22**
3. see section **13.3. Status Bar** in **page 23**
4. see section **13.4. Zooming ADC controls** in **page 24**
5. see section **13.4.5. General Controls** in **page 25**
6. see section **13.5. Voltage Control** in **page 28**
7. see section **13.6. Estimated Device Performances** in **page 28**
8. see section **13.7. Display Chart** in **page 30**

13 Main Window

13.1 Menu Tool Bar

The *Menu tool bar* contains four drop down menus, *File Menu*, *Action Menu*, *Tools Menu* and *Help Menu*.

13.1.1 File Menu

- *Connect / Disconnect* allows the connection or disconnection of the board from the host PC. This functionality can also be accessed through the short cut buttons of the *Window Toolbar* (see **13.2. Window Tool Bar**).
- *Open Config...* allows for the opening of SX8724xEVK configuration files (.cfg). This is implemented through a standard Windows file dialog box and may also be accessed through the short cut buttons of the *Window Toolbar*.
- *Save Config* allows for SX8724xEVK configuration files (.cfg) to be saved. This is implemented through a standard Windows file dialog box. The default file name is the last saved configuration file.
- *Save Config as...* prompts for a new file name before saving, allowing for multiple configuration files to be saved and may also be accessed through the short cut buttons of the *Window Toolbar*.
- *Exit* closes the application.

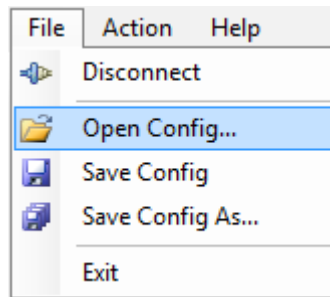

Figure 14. File Menu Options

13.1.2 Action Menu

- *Reset* resets the SX8724C configuration registers to the default values by sending an I2C General Call Reset command.
- *Refresh* reads all SX8724C registers and updates the GUI controls.
- *Show registers* toggles the SX8724C Registers display window and may also be accessed through the short cut buttons of the *Window Toolbar*. The register display window indicates the status of SX8724C

configuration registers as detailed in the SX8724C datasheet. Refer to **15. Registers Display Window** section for further information.

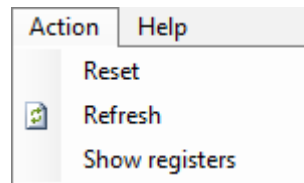

Figure 15. Action Menu Options

13.1.3 Help Menu

- *Help* opens a HTML help window with GUI controls descriptions.
- *User's Guide...* opens a PDF version of the User Guide.
- *About...* provides details of the GUI revision. The latest version of the GUI can be downloaded from Semtech web site.

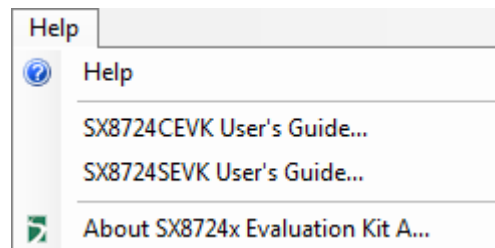

Figure 16. Help Menu Options

13.2 Window Tool Bar

The *Windows Tool Bar* contains buttons that provide shortcuts to some of the functions accessed from the drop-down menus.



Figure 17. Windows Tool Bar Menu

- *Open Config, USB Connect / Disconnect* and *Save Config* buttons provides a direct control of the actions described in **13.1.1. File Menu** section. A configuration file illustrated below in **Figure 18**.
- *Reset, Refresh* and *Show registers* provides a direct control of the actions described in **13.1.2. Action Menu**
- *I2C address* button set the I2C device address that the GUI will access.
- *Help* button provides a direct control of the actions described in **13.1.3. Help Menu**.

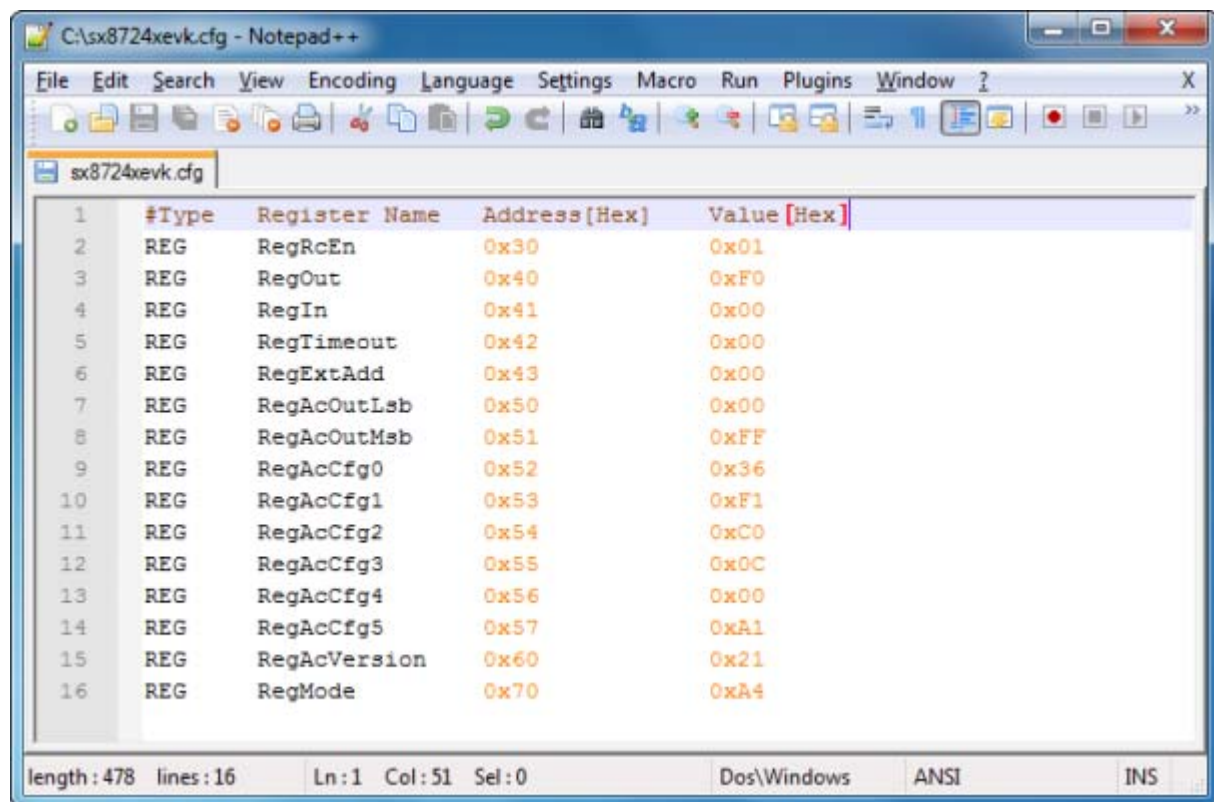

	#Type	Register Name	Address [Hex]	Value [Hex]
1				
2	REG	RegRcEn	0x30	0x01
3	REG	RegOut	0x40	0xF0
4	REG	RegIn	0x41	0x00
5	REG	RegTimeout	0x42	0x00
6	REG	RegExtAdd	0x43	0x00
7	REG	RegAcOutLsb	0x50	0x00
8	REG	RegAcOutMsb	0x51	0xFF
9	REG	RegAcCfg0	0x52	0x36
10	REG	RegAcCfg1	0x53	0xF1
11	REG	RegAcCfg2	0x54	0xC0
12	REG	RegAcCfg3	0x55	0x0C
13	REG	RegAcCfg4	0x56	0x00
14	REG	RegAcCfg5	0x57	0xA1
15	REG	RegAcVersion	0x60	0x21
16	REG	RegMode	0x70	0xA4

Figure 18. Example Configuration File Text Editor Output

13.3 Status Bar

The Status Bar provides error messages, the onboard SX8724C version and the current user configuration file. For further information concerning the IC revision, please refer to the SX8724C datasheet.

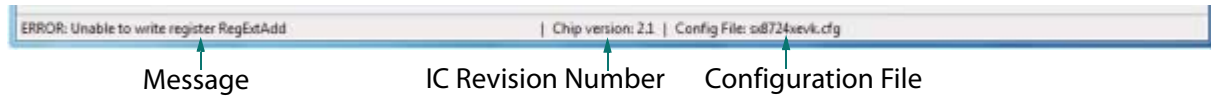

Figure 19. Status Bar

13.4 ZoomingADC controls

The ZoomingADC control sections allows the user to configure the acquisition chain of the SX8724C by selecting the control corresponding to the desired mode. Note that the settings are applied to the device registers as soon as the control is changed.

The representation picture on the top gives an indication of the settings applied to the ZoomingADC.

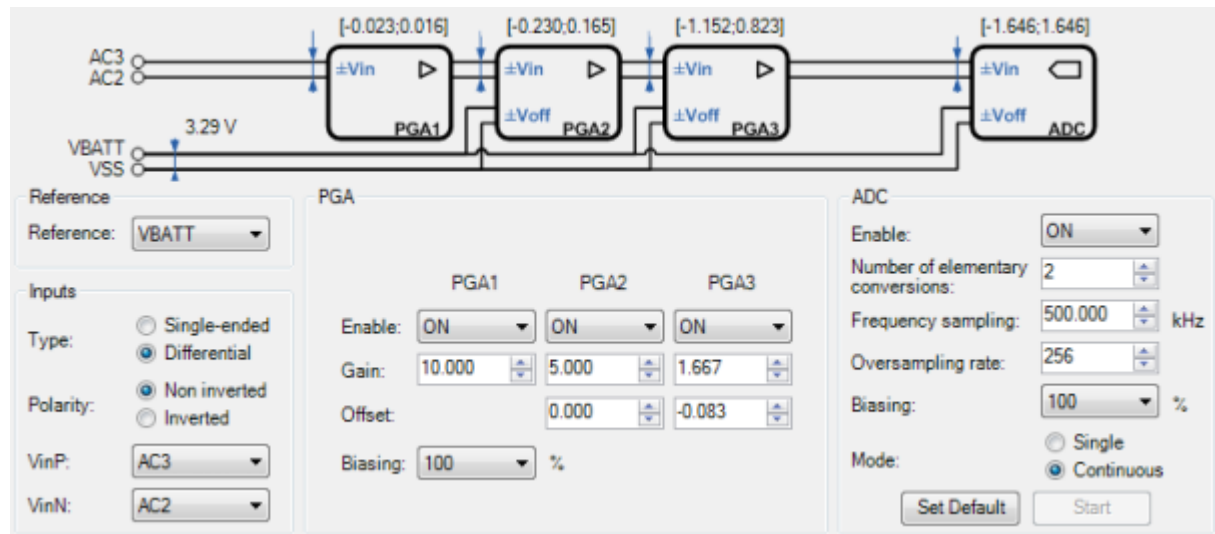

Figure 20. ZoomingADC Control Sections

13.4.1 Reference selection control

This control allows to choose the reference voltage of the acquisition chain. This can be the internally generated VREF with a nominal value of 1.22V or VBATT (2.4V to 5.5V).

When the control selects VREF, it can also be selected combined with a GPIO to provide a reference voltage from GPIO. See [Section 13.4.7](#) for details.

13.4.2 Inputs controls

The controls in the group named "Inputs" lets the user choose which inputs and which reference pins will be used to make the measurement. On this group of controls the user may also choose if the inputs are "Single-ended" or "Differential" as well as choosing which of the inputs is used as "Positive" or "Negative" input.

13.4.3 PGA controls

The group of controls named "PGA" lets the user control the gain, offset and enabling disabling each PGA individually.

The user has also the possibility to control the PGAs biasing current ratio.

13.4.4 ADC controls

The group of controls named “ADC” lets the user control the ADC parameters. Parameters like number of elementary conversions, the over-sampling rate, the sampling frequency at the input and the ADC biasing current ratio can be tuned.

Select the correct input sampling frequency depending on the required input impedance and conversion time. If necessary and/or possible, the power consumption can be reduced using the biasing parameters.

However, if the biasing current is too low, the performance of the ZoomingADC will be adversely affected. Select the ADC parameters for the required resolution using over-sampling rate (OSR) and number of elementary conversions (NELCONV). Prefer over-sampling rate since it increases much faster the resolution than NELCONV. If the offset is important, select a number of elementary conversions > 1.

The user has also the possibility to decide if the ADC will work in single shot or in continuous mode of samples acquisition.

13.4.5 General Controls

The general control provides an indication of the status of the GPIO and settings. Please refer to the SX8724C datasheet for a detailed description.



Figure 21. General Control

13.4.6 RC Oscillator

The *RC oscillator* provides the master clock reference for the chip. It produces a clock at 4 MHz which is divided internally in order to generate the clock sources needed by the other blocks.

It can be disabled to set the device in a low power mode. Any I2C command will wake up the RC oscillator automatically.

13.4.7 GPIO

The direction of each bit within the GPIO block (input only or input/output) can be individually set using the GPIO controls. If direction is set as “OUT”, the corresponding pin can be set as output high or low. The digital pins are able to deliver a driving current up to 8 mA.

D0 and D1 are multi-functional pins, see **13.4.8. Mode**. for GPIO with VREF functionality.

13.4.7.1 I2C time-out

I2C time-out provides control to enable or disable the time-out on SCL signal. If enabled, the digital interface is reset if the SCL is low more than 30ms. This is the default mode at startup. The time-out can be disabled with the corresponding radio button.

13.4.7.2 External Address

External address set D0 and D1 as input address bits for I2C interface. Please note that the GPIO are set as output low at startup, so a resistor should be connected to the pad to avoid shortcut if this option is used.

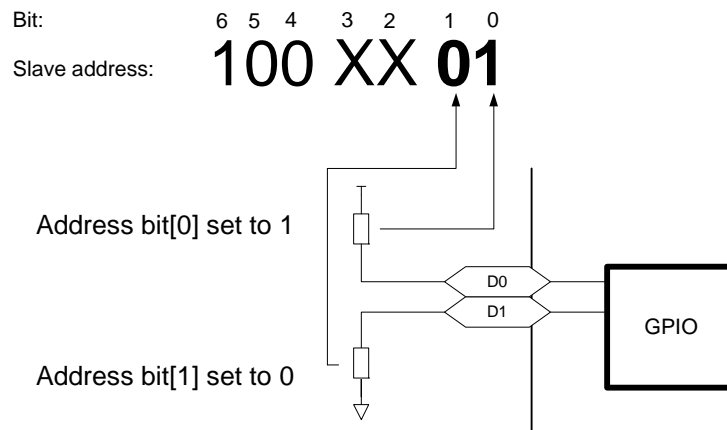

Figure 22. I2C Address Set Externally

When the External address option has been selected, the new I2C address of the SX8724C device must be selected in the windows tool bar (see [Section 13.2](#))

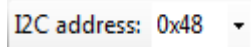

Figure 23. I2C Address Selection

13.4.8 Mode

- *Charge pump force ON and OFF* allows to force ON or OFF the internal voltage multiplier to avoid conversion interruptions due to the pump switching off and on when the VBATT supply is near 3V. Force ON takes priority to Force OFF.
- *VREF chopping control* allow chopping of the 1.22V internal bandgap reference. This helps to eliminate bandgap related internal offset voltage and 1/f noise. The bandgap chop state may be forced *High* or *Low*, or may be set to toggle during conversion at either the same rate or half the rate of the Elementary Conversion.
- *Bandgap on D0 pin*, outputs the SX8724C internal VREF on D0 pin. This allows external monitoring of the internal bandgap reference or the ability to use an external reference input for the ADC, or the option to filter the internal VREF output before feeding back as VREF,ADC input.

- *VREF on D1 pin* allows to select D1 pin as reference voltage for the acquisition chain. As described in **Section 13.4.1**, D1 can input a VREF. When using an external VREF,ADC input, it may have any value between 0V and VBATT.

13.5 Voltage Control

The voltage control allows to select or read the board voltage. This allow the GUI to compute ZoomingADC parameters and data values function of the registers settings in the GUI, for example the estimated device performance. VBATT is read at the connection of the EVK or when the External VREF setting is changed.

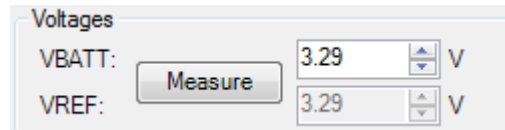

Figure 24. Voltage Control

Note that the VBATT voltage or external VREF voltage are estimated according to a 1.22V bandgap reference. For more precise data values in the GUI, the User has the possibility to set manually the real device voltage value.

13.6 Estimated Device Performances

These data are theoretical values extracted from registers settings and computed according to the equations available in the datasheet. The values expressed in Volt units [V] are function of the VREF voltage set by the user (**13.5. Voltage Control**) in the GUI.

Estimated device performances	
Input impedance:	361.011 kΩ
Input referred noise:	486.989 nVrms
Total gain:	83.333 V/V
Total offset:	-83.333 mV
Output noise:	40.582 μVrms
Resolution:	16.000 bits
LSB:	600.320 nV
Tconv:	4.114 ms
Telconv:	514.000 μs
Sample rate:	243.072 Hz

Figure 25. Computed Data Display

- Input impedance** – observed input impedance of the first PGA stage that is enabled or the input impedance of the ADC if all three stages are disabled. C_g multiplied by gain is the equivalent gain capacitor and C_p is the parasitic capacitor of the first enabled stage. The applied equation is:

$$Z_{in} = \frac{1}{(C_g \cdot GD + C_p)} \quad [\Omega]$$

- Input referred noise** – the simple noise model described in the datasheet is used to estimate the equivalent input referred rms noise $V_{N,IN}$ of the acquisition chain. It is computed with the extracted rms output noise

of PGA1, 2, and 3, standard output deviation and output rms noise voltage. V_{N1} , V_{N2} , and V_{N3} are the output rms noise figures (constants). GD_1 , GD_2 , and GD_3 are the PGA gains of stages 1 to 3 respectively, set by the user in the GUI:

$$V_{N,IN} = \sqrt{\frac{\left(\frac{V_{N1}}{GD_1}\right)^2 + \left(\frac{V_{N2}}{GD_1 \cdot GD_2}\right)^2 + \left(\frac{V_{N3}}{GD_{TOT}}\right)^2}{(OSR \cdot N_{ELCONV})}} \quad [V_{rms}]$$

- **Total gain** – the total gain of the acquisition chain is the product of all individual gains:

$$GD_{TOT} = GD_1 \cdot GD_2 \cdot GD_3 \quad \left[\frac{V}{V}\right]$$

- **Total offset** – the total offset of the acquisition chain is computed according to the PGA2 and PGA3 offset controls. Additionally, this total offset is function of the contribution of PGA3 gain. Therefore, the total offset is computed as:

$$GDoff_{TOT} = GDoff_3 + GD_3 \cdot GDoff_2 \quad \left[\frac{V}{V}\right]$$

- **Output noise** – the output noise is computed using the input noise value multiplied by the total gain of the PGAs as follows:

$$V_{N,OUT} = V_{N,IN} \cdot GD_{TOT} \quad [V_{rms}]$$

- **Resolution** – the theoretical resolution of the ADC, without considering thermal noise, is given by:

$$Q = 2 \cdot \text{Log}_2(OSR) + \text{Log}_2(N_{ELCONV}) \quad [bit]$$

- **LSB** – the least-significant bit of ADC output codes. The total range (or span) of the 16-bit ADC is 2^{16} LSBs, ratiometric to the voltage reference:

$$LSB = \frac{V_{REF}}{2^{16}} \quad [V]$$

- **T_{CONV}** – the time of the conversion sequence for one sample is computed as:

$$T_{CONV} = \frac{N_{ELCONV} \cdot (OSR + 1) + 1}{f_S} \quad [s]$$

- T_{ELCONV} – the whole conversion sequence is made of a set of NELCONV elementary incremental conversions. The conversion time for an elementary conversion:

$$T_{ELCONV} = \frac{(OSR + 1)}{f_s} \quad [s]$$

- *Sample rate* – the ADC output sample rate is computed with the TCONV time:

$$samplerate = \frac{1}{T_{CONV}} \quad [Hz]$$

13.7 Display Chart

The display chart is a graphic representing the ADC output samples. An enlarged graph including a histogram and measured system performance is available when pressing the button and is described in **14. Zooming ADC Data Display Window** section.

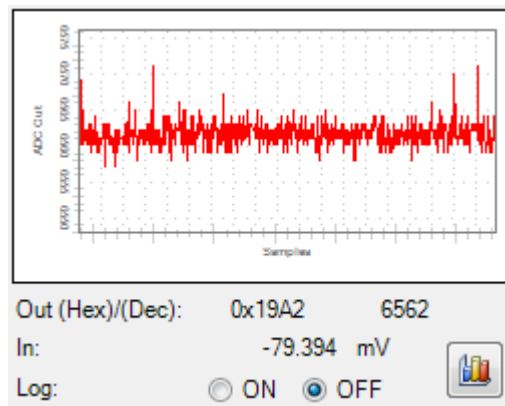

Figure 26. Display Chart

13.8 Log Data to File

Set the *Log* selector to ON to access the Log control:

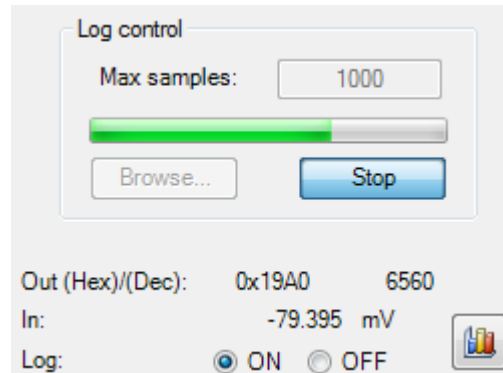

Figure 27. Log Controls

- *Max sample* input box indicates how many ZoomingADC samples are stored in the log file.
- *Browse...* button let the user choose where to store the log file and which name it will have.
- *Start/Stop* start the logging process or stop it. While the logging process is running a progress bar will show the progress.

14 ZoomingADC Data Display Window

The windows described in this section are only accessible for enabled configurations in the GUI.

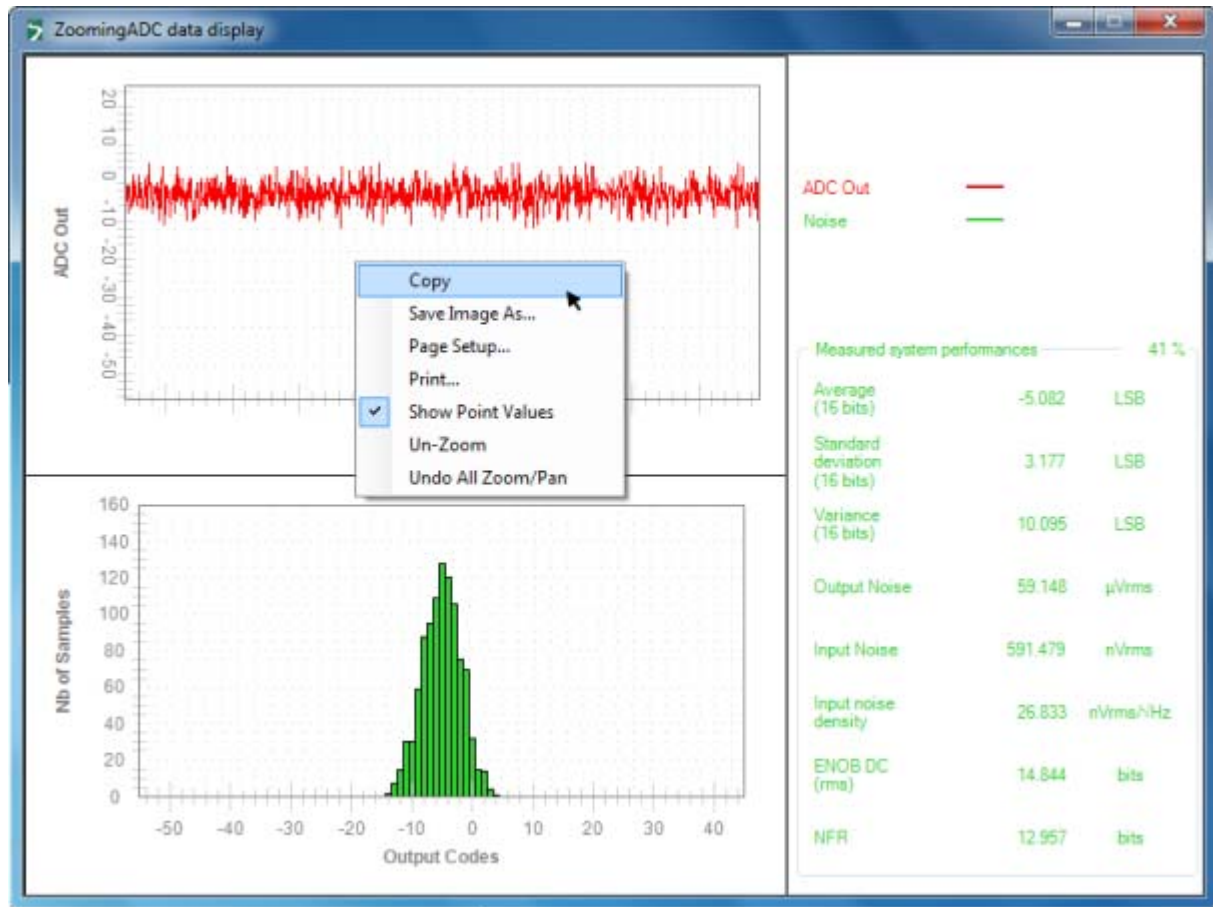

Figure 28. ZoomingADC Data Display Window

14.1 ZoomingADC data display panel

By default, the samples are displayed in the panel in a range from -32768 to 32767 LSB.

Various options allows the user to display the small signals as described below. Note that the following panel options are available in the small display chart described in **13.7. Display Chart**.

14.1.1 Zoom (left click on the panel)

If the user draws a rectangle in the graphic and then release the mouse button the graphic will zoom the signal inside the rectangle.

14.1.2 Zoom and Pan Via Mouse Scroll

The mouse scroll (if available) can be used to pan or zoom. It zooms in when you spin the scroll towards you and zooms out when you spin it towards the display panel. Holding it pushed also enables the pan command. To reset the display to default range, the right button of the mouse provides the *Undo All Zoom/Pan* operation (see **Section 14.1.3**.)

14.1.3 Display Options (right click on the panel)

- *Copy...* allows the user to copy the display panel into the clip-board. Then the curve can be past in any other program.
- *Save Image As...* allows to save the display panel into various common picture formats.
- *Page Setup...* provides the settings for printing the panel
- *Print...* allows to select an installed printer and print the display panel.
- *Show points Values* displays the sample value by pointing on any location on the curve.
- *Un-Zoom* allows the user to zoom out (with a small step) the display panel if the wheel is not available.
- *Undo All Zoom/Pan* resets the display range to it's default values.

14.2 Histogram Panel - Noise Analysis

The distribution of the codes from the acquired signal can be seen on the Histogram panel.

The Histogram graph is computed from a buffer of 1000 consecutive samples. Therefore, the refresh rate is dependant of the sample rate. If the signal is DC, the distribution width shows the noise.

The samples are coded on 16 bits, if the digital resolution is set to lower than 16bits, some output codes will never be hit.

14.3 Measured System Performances

The right value for the Measured System Performances is correct only when the DC signal is applied on the inputs. The values expressed in Volt units [V] are function of the VREF voltage set by the user (**13.5. Voltage Control**) in the GUI.

The measured system performances are computed as follows:

- *Average*– average of the code distribution measured on a buffer of 1000 samples. If the input is 0V, the average is equal to the output offset:

$$\mu = \frac{1}{N} \Sigma(\text{samples}) \quad [LSB]$$

- *Standard Deviation* – the standard deviation is the rms value (Root Mean Square) of the code distribution:

$$\sigma = \sqrt{\frac{1}{N} \Sigma(\text{sample} - \text{average})^2} \quad [LSB]$$

- *Output noise* – the output noise rms $V_{N,OUT}$ is computed with the standard deviation of the code distribution:

$$V_{N,OUT} = \sigma \times \frac{V_{REF}}{2^{16}} \quad [V_{rms}]$$

- *Input referred noise* – $V_{N,IN}$ is the rms noise referred to the input. This parameter is computed from the output rms noise (code) and the total PGA gain:

$$V_{N,IN} = \frac{V_{N,OUT}}{GD_{tot}} \quad [V_{rms}]$$

- *Noise Density (referred to the input)* – the input noise density $V_{ND,IN}$ is computed according to sample rate previously computed in the software with OSR , $NELCONV$ and f_s parameters:

$$V_{ND,IN} = \frac{V_{N,IN}}{\sqrt{samplerate}} \quad \left[\frac{V_{rms}}{\sqrt{Hz}} \right]$$

- *ENOB DC* – Effective Number Of Bits (or Effective Bits)¹ – is computed according to the σ samples rms noise value. This value is a DC ENOB measure, not the dynamic ENOB that is measured using FFT and SINAD. Its equation is as follows:

$$ENOB = 16 - \text{Log}_2(\sigma) \quad [bits]$$

- *NFR* – the Noise Free Code Resolution (or flicker-free resolution) is the number of bits of resolution beyond which it is impossible to distinctly resolve individual codes. Multiplying by a factor of 6.6 converts the samples rms noise into a useful measure of peak-to-peak noise:

$$NFR = 16 - \text{Log}_2(\sigma \cdot 6.6) \quad [bits]$$

1. Digital averaging increases resolution and reduces noise. The effects of input-referred noise is reduced by digital averaging on the buffer of samples used to compute the Measured System Performances. Therefore, the ENOB DC value can be higher than the sample width limitation (>16 bits).

15 Registers Display Window

As outlined in Section **13.2. Window Tool Bar** the SX8724x GUI has a show registers utility that, when enabled from either the Menu or Windows tool bar, provides details of the status of all configuration registers that are documented in the SX8724C datasheet.

Whenever the contents of a register are changed in the main GUI window, the corresponding register displays the new contents of the register(s), highlighting changed contents in red for a period of approximately 5 seconds before reverting back to black.

The register window is displayed below in **Figure 29**.

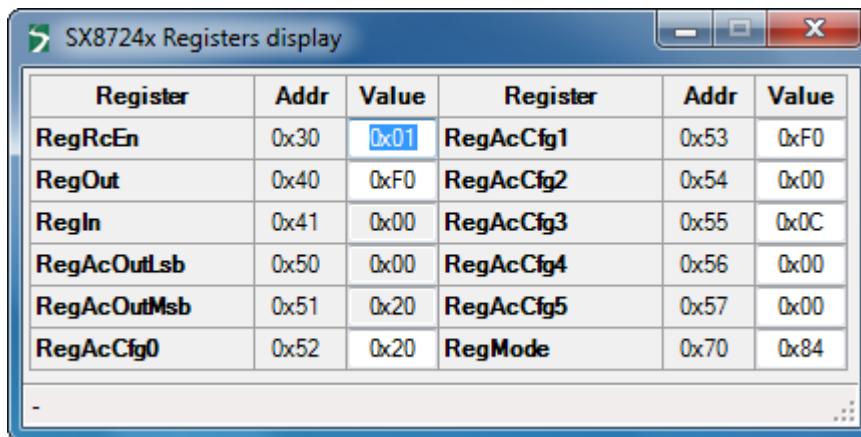

Register	Addr	Value	Register	Addr	Value
RegRcEn	0x30	0x01	RegAcCfg1	0x53	0xF0
RegOut	0x40	0xF0	RegAcCfg2	0x54	0x00
RegIn	0x41	0x00	RegAcCfg3	0x55	0x0C
RegAcOutLsb	0x50	0x00	RegAcCfg4	0x56	0x00
RegAcOutMsb	0x51	0x20	RegAcCfg5	0x57	0x00
RegAcCfg0	0x52	0x20	RegMode	0x70	0x84

Figure 29. SX8724x Registers Display Window

16 Verification Mode Window

When no board is connected to the PC, launching the application results in the GUI display being grayed out and the user is unable to enter data.

By depressing the <CTRL>+<ALT>+<N> keys of the PC keyboard simultaneously, the user can write to the configuration registers to verify propose settings, as well as load and save configuration files (*.cfg).

APPLICATION EXAMPLES

17 Interfacing your first pressure sensor

17.1 Introduction

This chapter intends to show how to interface a pressure sensor using the SX8724CEVK evaluation board. It also shows how to use efficiently the ZoomingADC™ of the SX8724C and demonstrate the benefits of the zooming feature.

17.2 Pressure Sensor

The chosen sensor for this application is a 200kPa absolute pressure sensor type MPX2202AP by Freescale. Its main characteristics are described in the table below:

Table 3. Sensor main characteristics

Characteristic	Value (Typ)	Unit
Pressure range	0-200	kPa
Supply voltage	3.3	Vdc
Supply current	3.3	mAdc
Full scale span	3.3	mVdc

17.2.1 Sensor Pinout & Schematic

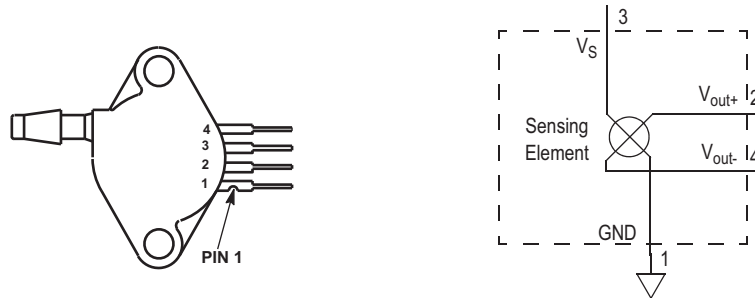

Figure 30. Pressure sensor pin out & equivalent schematic

17.2.2 Sensor Transfer Function

The transfer function of the sensor is given in the figure below. It shows the output voltage (min., typ. and max.) as a function of the absolute input pressure for the specified supply voltage.

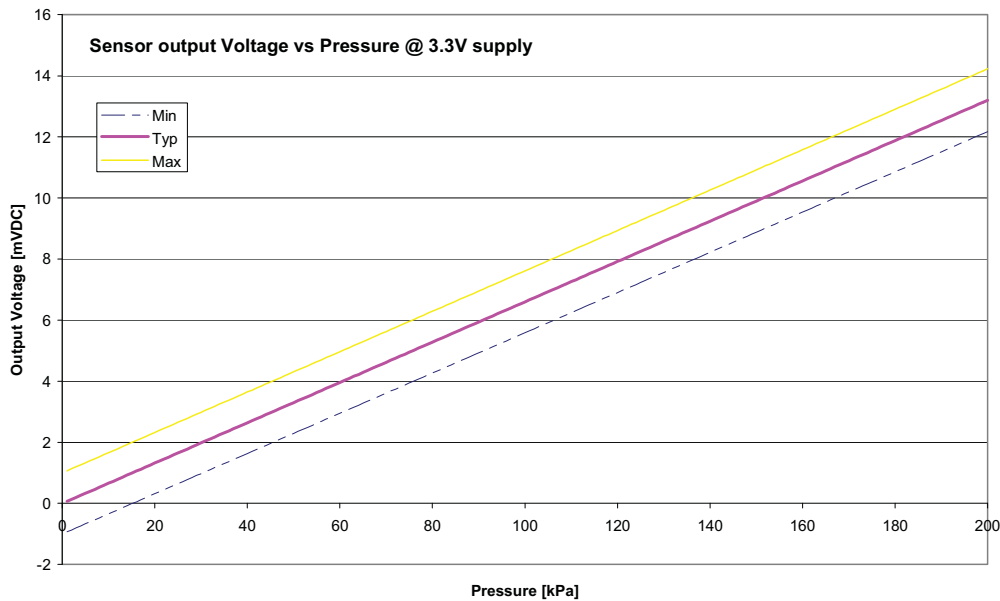

Figure 31. Sensor transfer function

Note: The given transfer function in the datasheet is for a 10V power supply, here the transfer function was translated for a 3.3V power supply.

17.2.3 Sensor Connection to the SX8724C

The schematic below shows how the sensor is connected to the SX8724C using the pins AC2–AC3 as differential input. The default VMUX setting will select VBATT–VSS as reference inputs for the acquisition chain.

The sensor will be biased with VBATT when D0 is set as digital output high state. It will be switched on/off by the register setting.

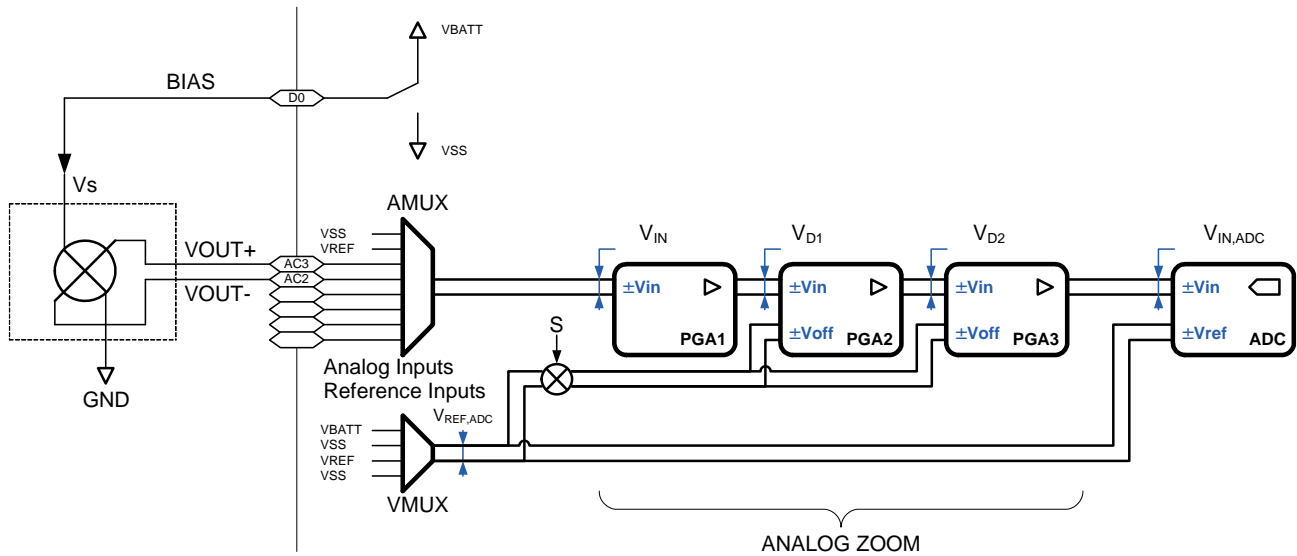

Figure 32. Sensor schematic connection to the SX8724C

17.2.4 Sensor Connection to the Board

The picture below shows how to connect the sensor on the evaluation board, each red point represents a connection.

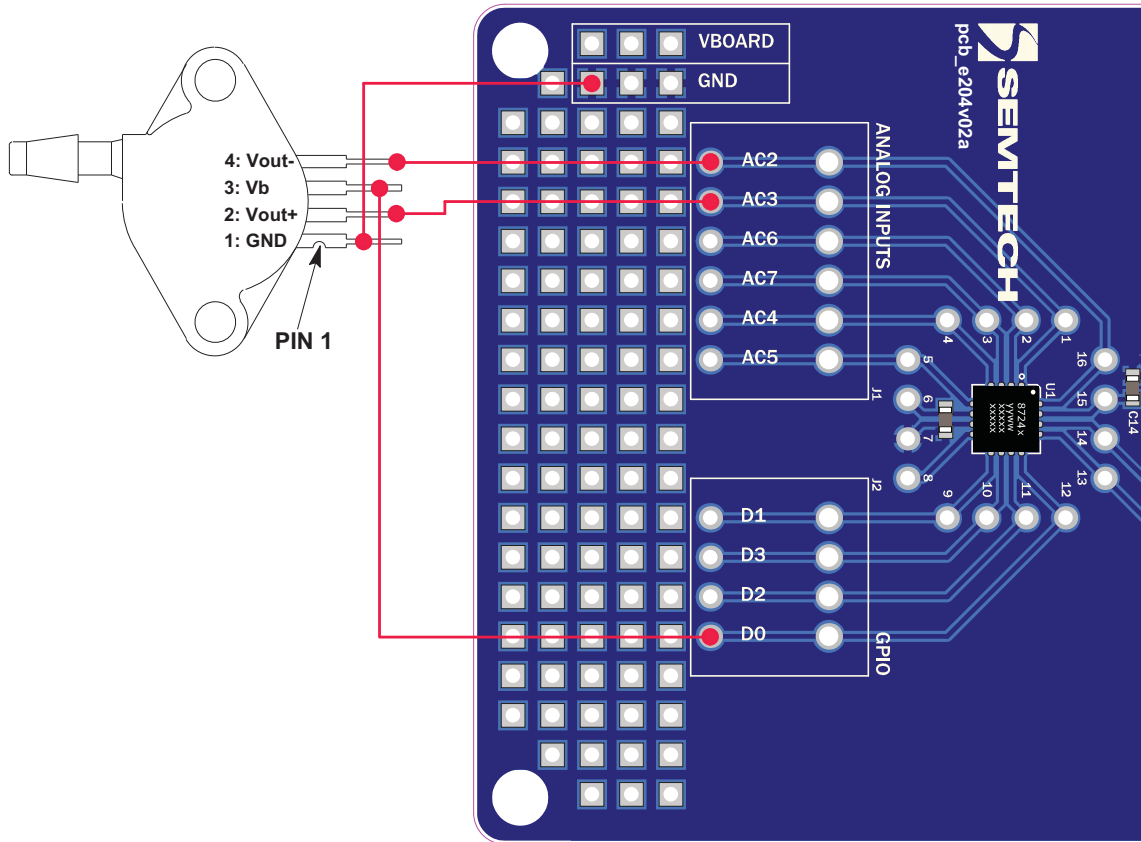

Figure 33. Connection on the SX8724CEVK Evaluation board

17.3 Using the Evaluation Board and the GUI

17.3.1 Configuration

1. Connect the sensor to the board as described in **Figure 33 on page 39**.
2. Select the power supply of the evaluation board to 3.3V (see chapter **“Power Supply Selection” on page 13** of the evaluation board user’s guide).
3. Connect the USB connector to the evaluation board and to the PC to power the board.
4. Launch the Graphical User Interface.
5. Start the connection to the EVK in the GUI.

17.3.2 Voltages Settings

In the “Voltages” group of controls, set the VBATT value to the corresponding value selected on the board: 3.3V. This has no influence for the board itself but allows correct data calculation in the GUI.

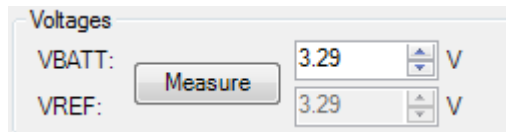

Figure 34. “Voltages” settings in the GUI

17.3.3 Sensor Biasing

After a Power-on-reset the GPIO are set to a digital output low state. The sensor bias is connected to D0 pin. Switch ON the “D0” “Out” control to set this GPIO as output high state to drive the sensor.

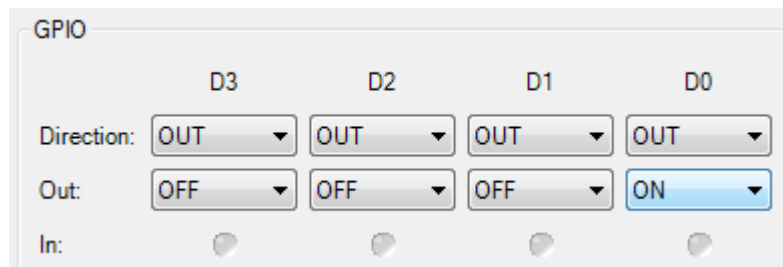

Figure 35. “GPIO” settings

17.4 Reading the sensor using the GUI

By default, if no configuration file is loaded the SX8724C state should look like in the picture beside. Press the "Set Default" button to start a default continuous acquisition mode to enable the acquisition chain.

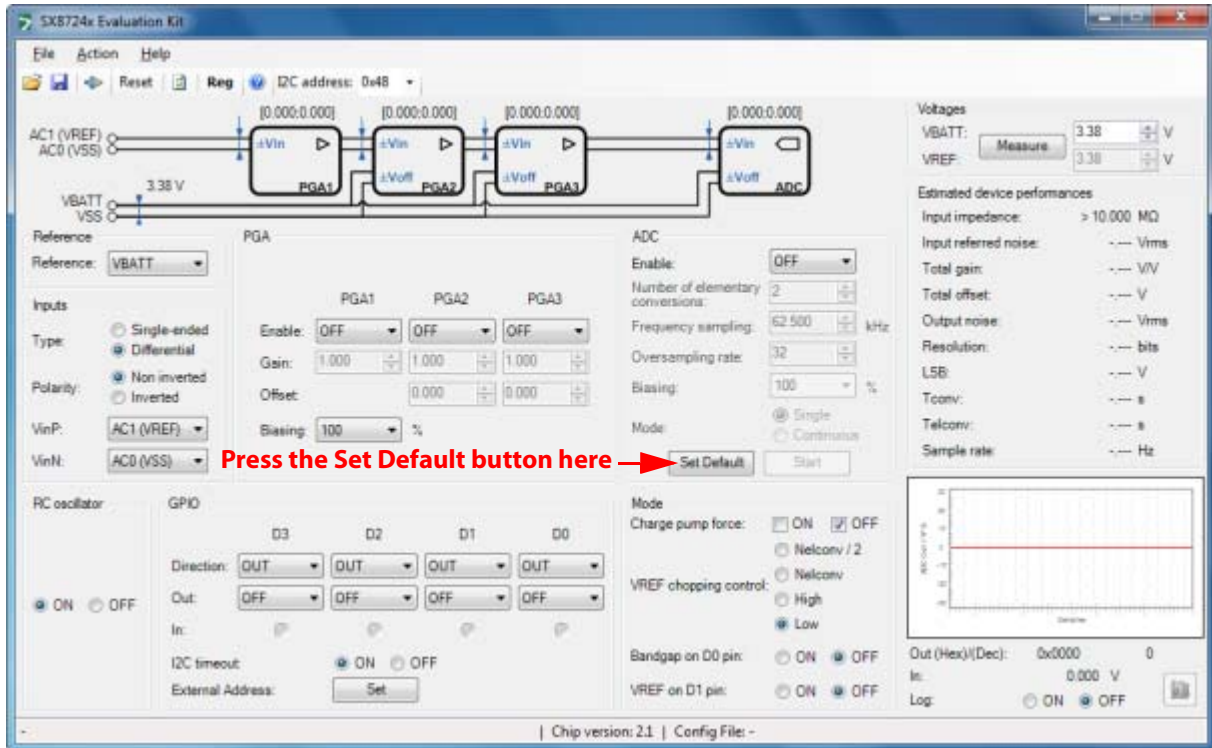

Figure 36. SX8724C default state

17.5 Reference Voltage Selection

After having pressed the "Set Default" button as described in "17.4 Reading the sensor using the GUI", the GUI sets the input reference (VMUX) to VREF (VREF-VSS). Change this and select VBATT as voltage reference for the acquisition chain. The "Reference" configuration control should look like the picture below

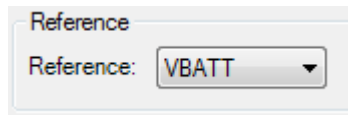

Figure 37. Reference Voltage Selection

17.5.1 Inputs Configuration

Select the AC3-AC2 analog inputs in differential mode as input channel. The “Inputs” configuration controls should look like the picture below

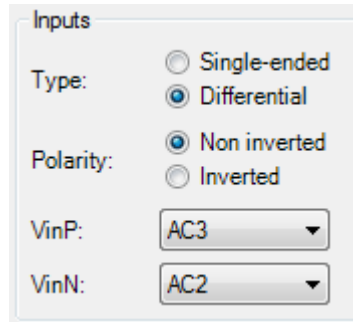

Figure 38. SX8724C “Reference” and “Inputs” Groups of Controls

Note: Function of the layout and the used sensor, to avoid crossing sensor Vout+ and Vout- on a board the SX8724C allows inverting the polarity of the inputs we will use the “sign inversion” feature during SX8724C configuration.

17.5.2 Rough Gain Configuration

As the transfer function shows, the total span of the sensor is 14.5mV and the total span of the ZoomingADC is 3.3V (VBATT).

The gain that needs to be applied to see the full range of the signal is then calculated as follows:

$$Gain = \frac{ADCOut_{Max}}{SensorOut_{Max}} = \frac{3300mV}{14.5mV} = 227$$

Equation 1

This means PGA1 gain GD1=10, PGA2 gain GD2=10 and PGA3 gain GD3=2.25 (granularity of PGA3 = 1/12).

The "PGA" controls should then look like the picture below.

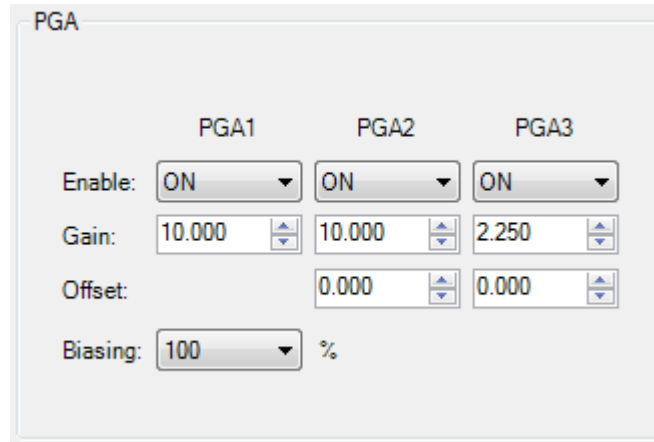

Figure 39. SX8724C "PGA" Group of Controls Configuration

17.6 Zooming ADC™ Configuration

17.6.1 Zooming on the Signal

As the sensor is supposed to work at the atmospheric pressure (max: 107.8kPa - min: 88.7kPa) we will zoom on around these values and thus use the maximum amplification as possible to get the full signal at the ADC input.

As for zoom in pictures we set a particular zone of interest called measuring window (in red below).

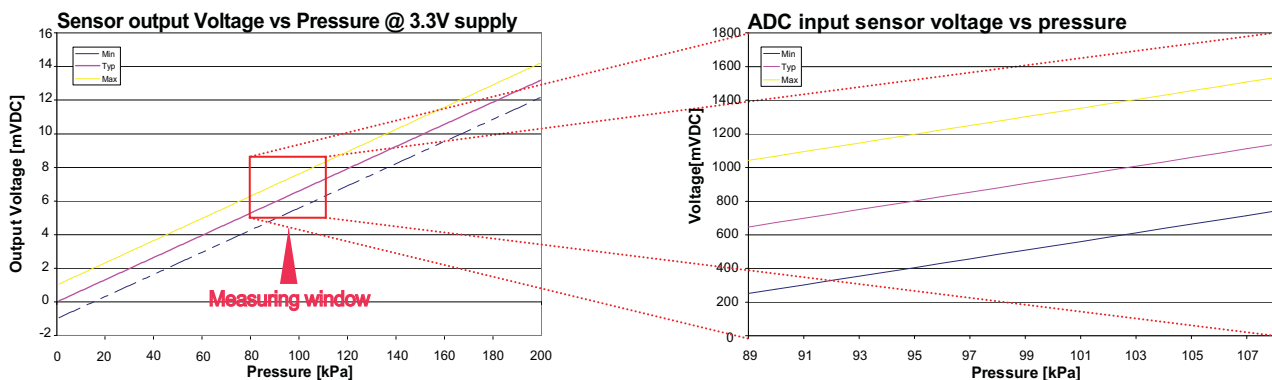

Figure 40. Zooming on the Signal

17.6.2 Gain Computing

To compute the total gain that must be applied to the sensor output signal we must know 2 parameters:

1. The maximum output span of the ADC, here 3.3V
2. The maximum output span value of the sensor in the measuring window, here around $8.5 - 4.5 = 4\text{mV}$

Now we can apply the following formula to get the gain:

$$Gain = \frac{ADCOut_{Max}}{SensorOut_{Max}} = \frac{3300mV}{4mV} = 825$$

Equation 2

As the total gain is more than 100, all PGAs have to be enabled to obtain a total amplification of 825. The gains must be set as follow:

- PGA1 = 10
- PGA2 = 10
- PGA3 = 8.25

17.6.3 Offset Cancellation

The offset computation uses the middle sensor output value at the ZoomingADC™ input as shown in the formula below:

$$Offset = \frac{Mw_{Max} - Mw_{Min}}{2} = \frac{8.5mV - 4.5mV}{2} = 6.5mV$$

Equation 3

Note: Mw stands for measuring window.

Offset removing PGA after PGAs:

- PGA1: Amplified sensor output = 6.5mV x 10 = 65mV
- PGA2: Amplified sensor output = 65mV x 10 = 650mV

Offset cancellation: min +/- 0.2 x VREF (3.3V x 0.2 = 660mV).

-> The minimum value is too big we cannot use the offset cancellation of PGA2.

- PGA3: Amplified sensor output = 650mV x 8.25 = 5362mV

Offset cancellation: min +/- 1/12 x VREF (1/12 x 3.3V = 275mV)

-> The minimum value fits up to 19 times in 5362mV 19/12 x 3.3 = 5225mV.

Note: 19/12 = 1.583

17.6.4 Final Gains Configuration

As computed, the PGA gains can be raised to 825.

The offset is 19/12 (see **“Offset Cancellation” on page 44**), as the input signal and the reference are non-inverted, the offset has to be positive.

The "PGA" group of controls should then look like as picture beside.

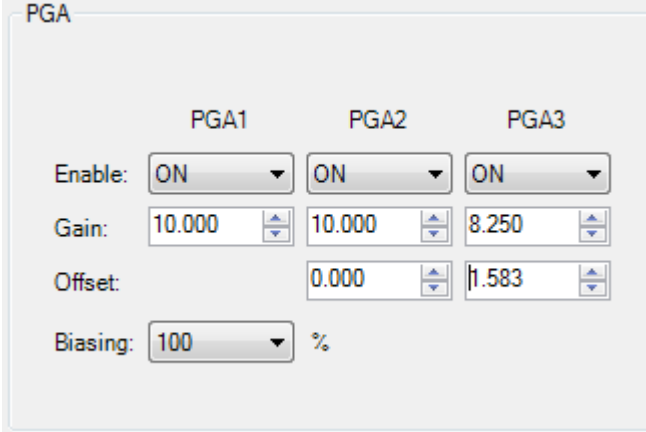

The screenshot shows a configuration window titled "PGA" with three columns for PGA1, PGA2, and PGA3. The settings are as follows:

	PGA1	PGA2	PGA3
Enable:	ON	ON	ON
Gain:	10.000	10.000	8.250
Offset:		0.000	1.583
Biasing:	100 %		

Figure 41. SX8724C "PGA" final configuration

17.7 ADC Configuration

The following PGA and ADC set-up is chosen to implement the measurement window. With this set-up, the input voltage range of the circuit corresponding to the full scale output code range is 4.5mV to 8.5mV. This window is represented in **Figure 40**.

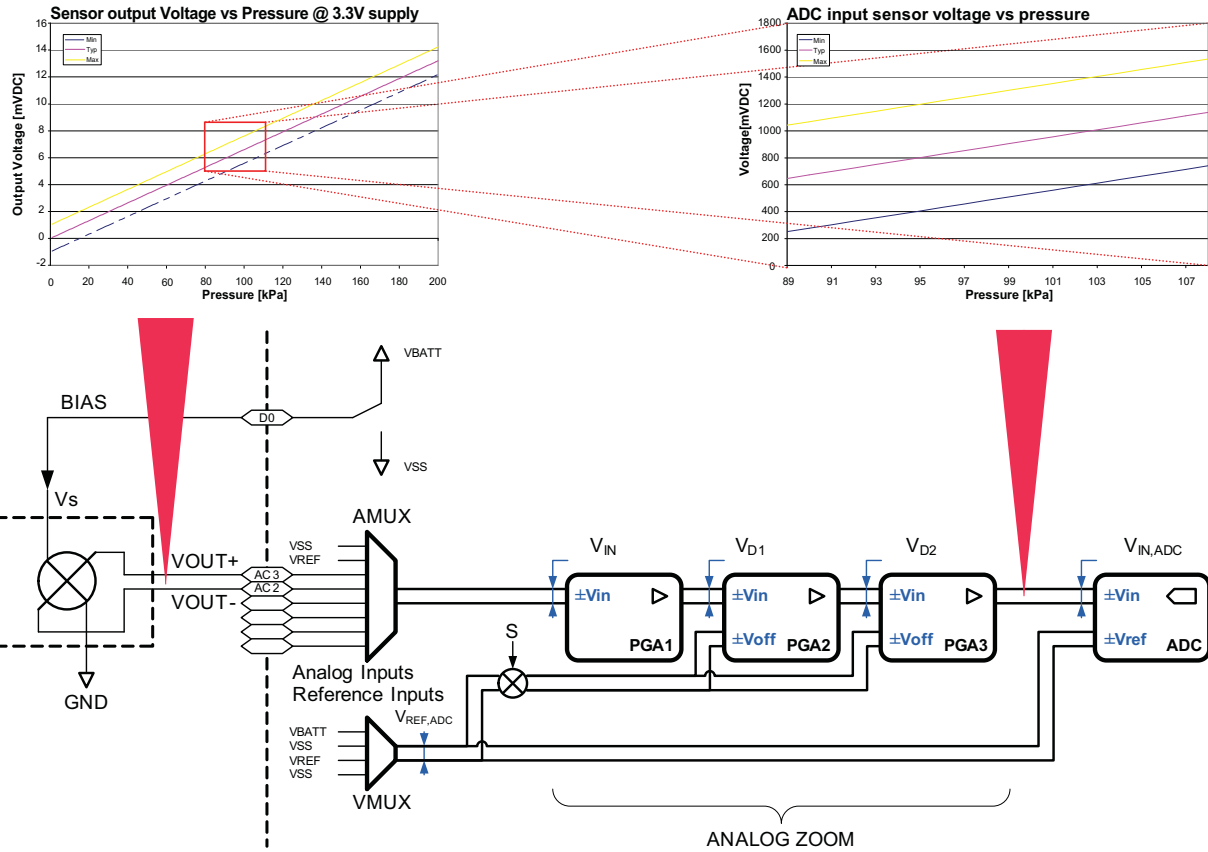

Figure 42. PGA Parameters

Table 4. ADC Configuration

Characteristic	Value (Typ)	Unit
$V_{BATT} = V_{REF}$	3.3	V
Sampling frequency	250	kHz
Gain of PGA1	10	V/V
Gain of PGA2	10	V/V
Gain of PGA3	8.25	V/V
Total PGA gain	825	V/V
Offset of PGA2	0.00	V_{REF}
Offset of PGA3	1.58	V_{REF}
Total equivalent input offset	6.33	mV
Over-sampling rate	512	
Elementary conversions	2	
Resolution ¹	16	bit
Conversion time	4.108	ms
LSB equivalent input voltage	62.47	nV
Equivalent input noise ²	649E-09	V _{rms}
PGA settling time	2.048	ms

1. ADC quantization noise only
2. PGA white noise included

17.8 Noise Cancellation

The OSR and NELCONV parameters can be increased in order to reduce the noise generated by the ADC and PGAs.

Noise with OSR=512, NELCONV=2:

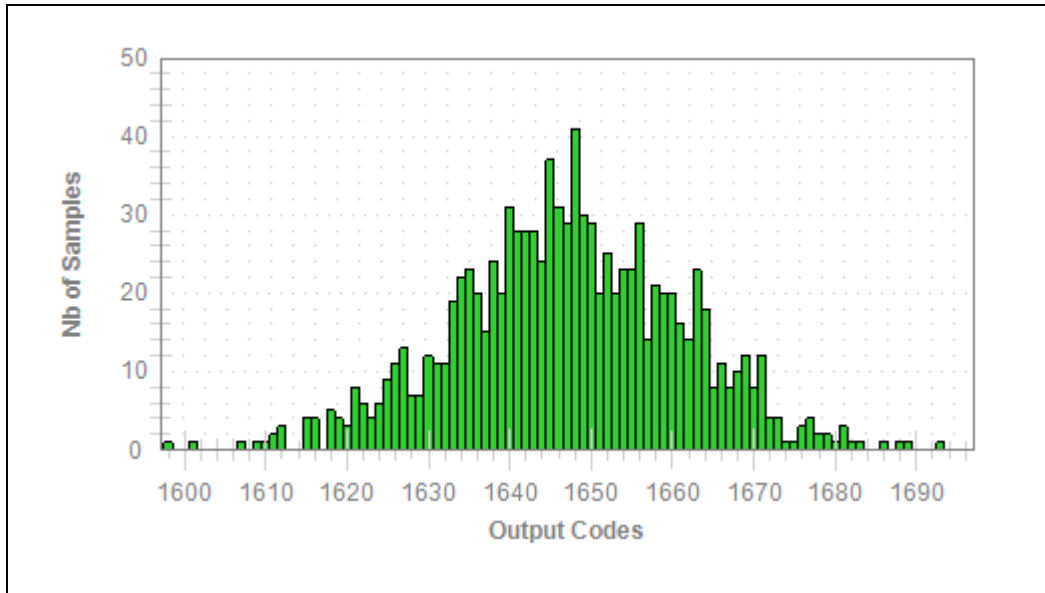

Noise with OSR=1024, NELCONV=8:

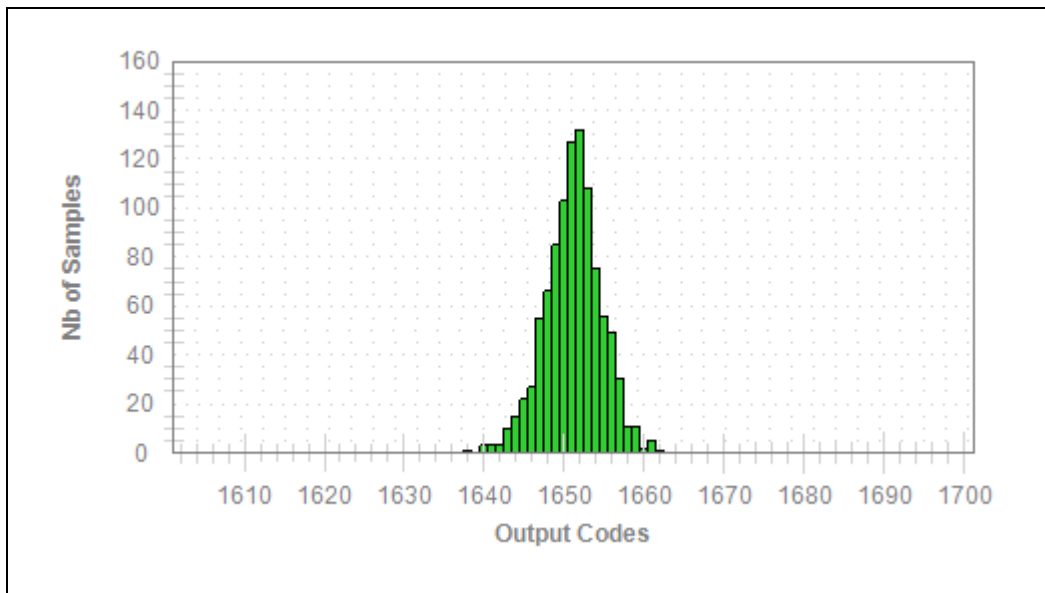

17.9 LSB Equivalence

Using the defined ADC and PGA set-up, an equivalent input pressure per LSB can be calculated. Using the typical sensor transfer function, we obtain:

$$Pressure = \frac{V_{LSB} \cdot pressureRange}{sensorVoltageRange} = \frac{63nV \cdot 200kPa}{13.04mV} = 0.96Pa$$

Equation 4

The approximate equivalence between Pressure and altitude is defined as follow:

$$Altitude = 100kPa \equiv 8620m \rightarrow \frac{0.96Pa \cdot 8620m}{100kPa} = 0.0079Pa$$

Equation 5

This implementation has a resolution of 8cm altitude.

17.10 ZoomingADC™ Benefits

Now that we zoomed on the signal, we can compare the zoom performances with and without the offset compensation. To make a comparison do as follow:

Without Zoom (gain only)

1. On the graph, set the full scale view: right click on the panel and select *Undo All Zoom/Pan* option to reset the display range to the default full scale range.
2. Set the configuration to Gain = 225 & no offset cancellation as in **17.5.2. Rough Gain Configuration** section.
3. Then blow in the sensor tube (try to make the maximum signal span).

The signal span correspond to $31923 - 28599 = 3324$ bits. The result should look like the picture below:

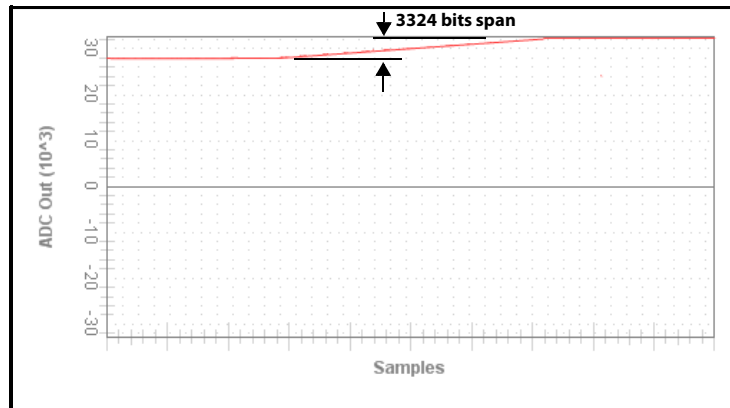

Figure 43. Signal Span Using Rough Gain Setting

With Zoom (gain and offset)

Now set the parameters as defined in **17.6.4. Final Gains Configuration** (Gain 825, offset $-1.58 \times V_{REF}$). The result should look like the picture below:

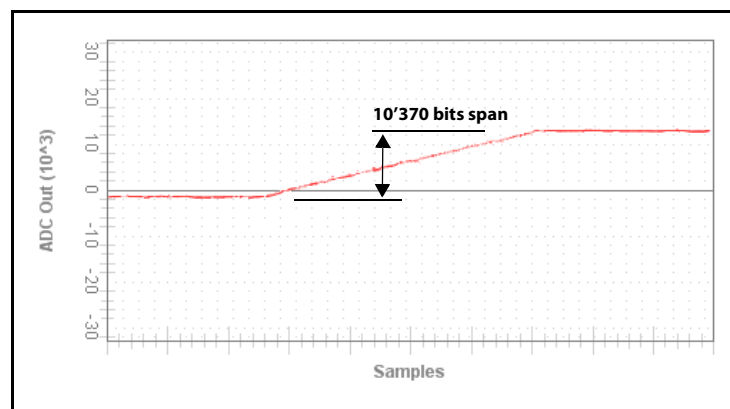

Figure 44. Signal Span Using Zooming Settings

The signal span is $11743 - 1374 = 10370$ bits which corresponds to a **320% gain on the signal reading** allowing you to have more consistent readings.

© Semtech 2011

All rights reserved. Reproduction in whole or in part is prohibited without the prior written consent of the copyright owner. The information presented in this document does not form part of any quotation or contract, is believed to be accurate and reliable and may be changed without notice. No liability will be accepted by the publisher for any consequence of its use. Publication thereof does not convey nor imply any license under patent or other industrial or intellectual property rights. Semtech assumes no responsibility or liability whatsoever for any failure or unexpected operation resulting from misuse, neglect improper installation, repair or improper handling or unusual physical or electrical stress including, but not limited to, exposure to parameters beyond the specified maximum ratings or operation outside the specified range.

SEMTECH PRODUCTS ARE NOT DESIGNED, INTENDED, AUTHORIZED OR WARRANTED TO BE SUITABLE FOR USE IN LIFE-SUPPORT APPLICATIONS, DEVICES OR SYSTEMS OR OTHER CRITICAL APPLICATIONS. INCLUSION OF SEMTECH PRODUCTS IN SUCH APPLICATIONS IS UNDERSTOOD TO BE UNDERTAKEN SOLELY AT THE CUSTOMER'S OWN RISK. Should a customer purchase or use Semtech products for any such unauthorized application, the customer shall indemnify and hold Semtech and its officers, employees, subsidiaries, affiliates, and distributors harmless against all claims, costs damages and attorney fees which could arise.

Notice: All referenced brands, product names, service names and trademarks are the property of their respective owners.

Contact information

Semtech Corporation Advanced Communications & Sensing Products

E-mail: sales@semtech.com or acsupport@semtech.com
Internet: <http://www.semtech.com>

USA 200 Flynn Road, Camarillo, CA 93012-8790.
Tel: +1 805 498 2111 Fax: +1 805 498 3804

FAR EAST 12F, No. 89 Sec. 5, Nanking E. Road, Taipei, 105, TWN, R.O.C.
Tel: +886 2 2748 3380 Fax: +886 2 2748 3390

EUROPE Semtech Ltd., Units 2 & 3, Park Court, Premier Way, Abbey Park Industrial Estate, Romsey, Hampshire, SO51 9DN.
Tel: +44 (0)1794 527 600 Fax: +44 (0)1794 527 601



Стандарт Электрон Связь

Мы молодая и активно развивающаяся компания в области поставок электронных компонентов. Мы поставляем электронные компоненты отечественного и импортного производства напрямую от производителей и с крупнейших складов мира.

Благодаря сотрудничеству с мировыми поставщиками мы осуществляем комплексные и плановые поставки широчайшего спектра электронных компонентов.

Собственная эффективная логистика и склад в обеспечивает надежную поставку продукции в точно указанные сроки по всей России.

Мы осуществляем техническую поддержку нашим клиентам и предпродажную проверку качества продукции. На все поставляемые продукты мы предоставляем гарантию .

Осуществляем поставки продукции под контролем ВП МО РФ на предприятия военно-промышленного комплекса России , а также работаем в рамках 275 ФЗ с открытием отдельных счетов в уполномоченном банке. Система менеджмента качества компании соответствует требованиям ГОСТ ISO 9001.

Минимальные сроки поставки, гибкие цены, неограниченный ассортимент и индивидуальный подход к клиентам являются основой для выстраивания долгосрочного и эффективного сотрудничества с предприятиями радиоэлектронной промышленности, предприятиями ВПК и научно-исследовательскими институтами России.

С нами вы становитесь еще успешнее!

Наши контакты:

Телефон: +7 812 627 14 35

Электронная почта: sales@st-electron.ru

Адрес: 198099, Санкт-Петербург,
Промышленная ул, дом № 19, литера Н,
помещение 100-Н Офис 331