

# CHY101 ChiPhy™ Family

## Charger Interface Physical Layer IC with Output Overvoltage Protection

### Product Highlights

- Supports Quick Charge 2.0 Class A specification
  - 5 V, 9 V, and 12 V output voltage
- USB battery charging specification revision 1.2 compatible
  - Automatic USB DCP shorting D+ to D- line
  - Default 5 V mode operation
- Adaptive output overvoltage protection (OVP)
  - Protection triggered at 120% of set output voltage
  - Latching or hysteretic shutdown mode
- Supports TOPSwitch, TinySwitch and InnoSwitch
- Very low power consumption
  - Below 1 mW at 5 V output
- Fail safe operation
  - Adjacent pin-to-pin short-circuit fault protection
  - Open circuit pin fault protection

### Typical Applications

- Battery chargers for smart phones, tablets, netbooks, digital cameras, and bluetooth accessories
- USB power output ports

### Description

CHY101 is a low-cost USB high-voltage dedicated charging port (HVDCP) interface IC for the Quick Charge 2.0 specification. It incorporates all necessary functions to add Quick Charge 2.0 capability to Power Integrations' switcher ICs such as TOPSwitch or TinySwitch and other solutions employing traditional feedback schemes.

CHY101 supports the full output voltage range of Class A (5 V, 9 V, and 12 V). CHY101 continuously monitors the output voltage and triggers OVP if the actual value exceeds 120% of the set value.

CHY101 automatically detects whether a connected Powered Device (PD) is Quick Charge 2.0 capable before enabling output voltage adjustment. If a PD not compliant to Quick Charge 2.0 is detected the CHY101 disables output voltage adjustment to ensure safe operation with legacy 5 V only USB PDs.

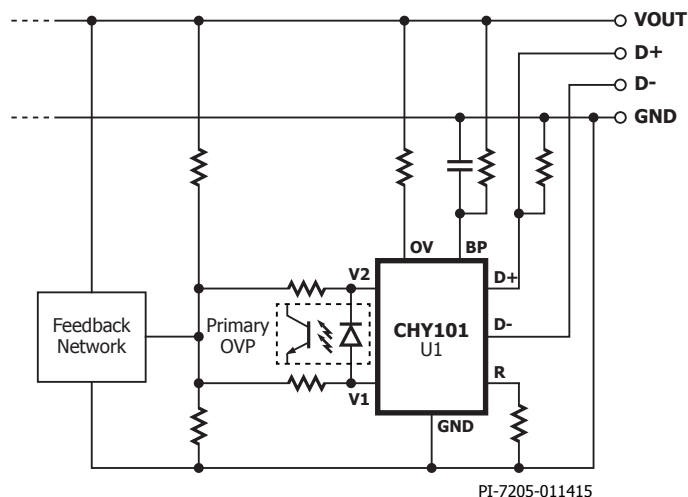
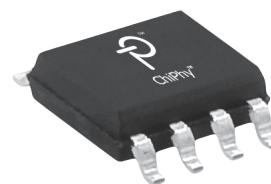

Figure 1. Typical Application Schematic.



SO-8 (D Package)

Figure 2. Package Option.

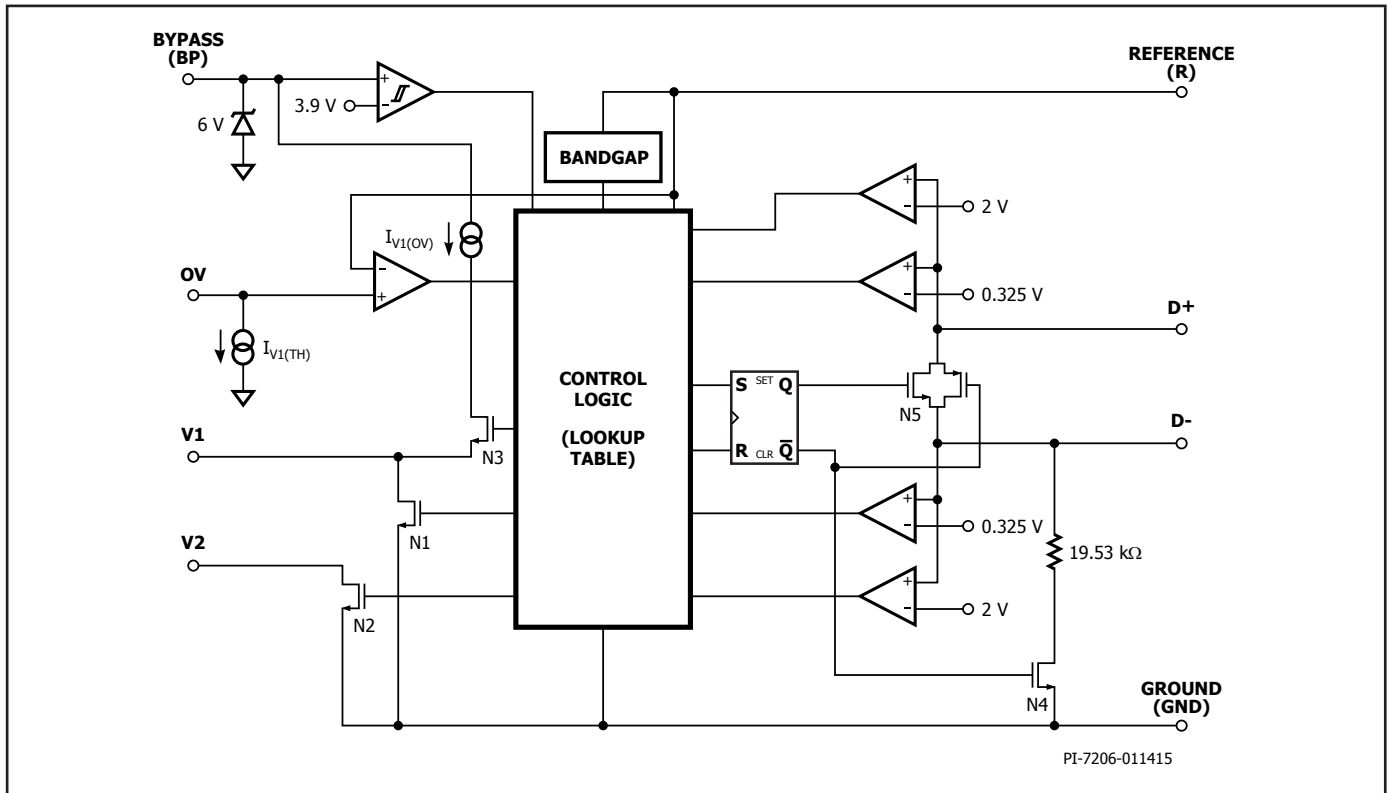

Figure 3. Functional Block Diagram.

## Pin Functional Description

### GROUND (GND) Pin:

Ground.

### V1 Pin:

Open Drain input of output voltage adjustment switch. Active for 9 V and 12 V output setting. Connection for optocoupler diode for primary-side latching OVP.

### V2 Pin:

Open Drain input of output voltage adjustment switch. Active for 12 V output setting. Connection for optocoupler diode for primary-side latching OVP.

### OV Pin:

Output overvoltage detection connected to the output through a sense resistor.

### BYPASS (BP) Pin:

Connection point for an external bypass capacitor for the internally generated supply voltage.

### REFERENCE (R) Pin:

Connected to internal band-gap reference. Provides reference current through connected resistor.

### DATA LINE (D+) Pin:

USB D+ data line input.

### DATA LINE (D-) Pin:

USB D- data line input.

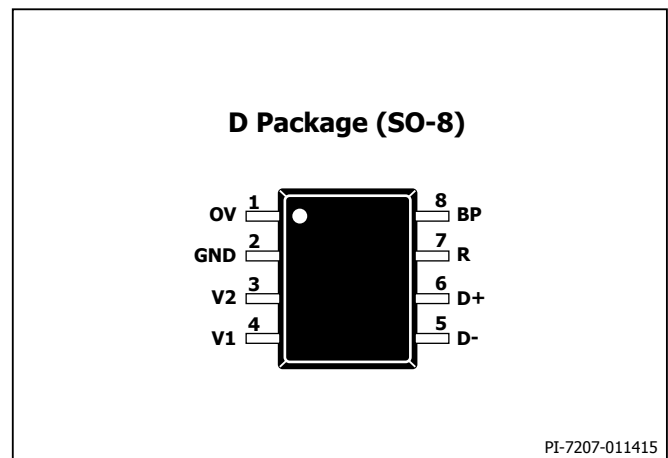

Figure 4. Pin Configuration.

## Functional Description

CHY101 is a low-cost USB high-voltage dedicated charging port (HVDCP) interface IC for the Quick Charge 2.0 specification. It incorporates all necessary functions to add Quick Charge 2.0 capability to Power Integrations' integrated switcher ICs such as TOPSwitch or TinySwitch.

CHY101 also supports other solutions with traditional feedback schemes like optocoupler and secondary reference regulator TL431 as depicted in Figure 5.

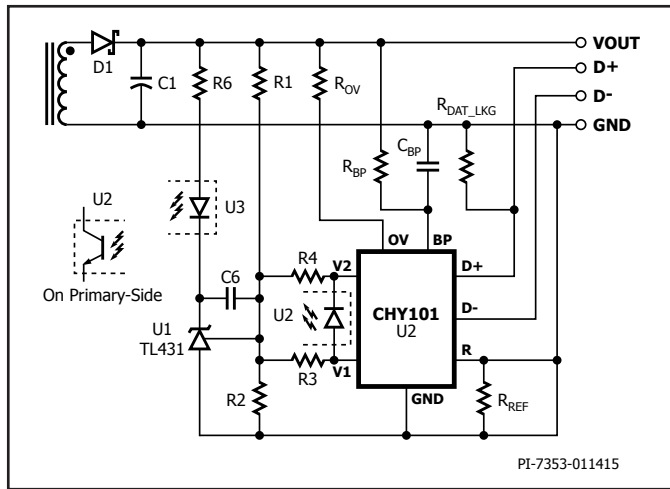

Figure 5. CHY101 with Traditional Output Regulation (CV Only).

CHY101 supports the full output voltage range of Quick Charge 2.0 Class A (5 V, 9 V, or 12 V). It automatically detects either Quick Charge 2.0 capable powered devices (PD) or legacy PDs compliant with the USB Battery Charging Specification revision 1.2 and only enables output voltage adjustment accordingly.

### Shunt Regulator

The internal shunt regulator clamps the BYPASS pin at 6 V when current is provided through an external resistor ( $R_{BP}$  in Figure 5). This facilitates powering of CHY101 externally over the wide power supply output voltage range of 5 V to 12 V. Recommended values are  $R_{BP} = 2.05 \text{ k}\Omega$  and  $C_{BP} = 680 \text{ nF}$ .

### BYPASS Pin Undervoltage

The BYPASS pin undervoltage circuitry resets the CHY101 when the BYPASS pin voltage drops below 3.9 V. Once the BYPASS pin voltage drops below 3.9 V it must rise back to 4 V to enable correct operation.

### Output Overvoltage Protection

The OV pin monitors voltage through resistor  $R_{OV}$ . As soon as the output voltage exceeds 120% of the set output voltage level (e.g. 10.8 V at 9 V set) a protection mode is turned on. In protection mode V1 is pulled low and V2 is pulled up to the BYPASS pin.

This can for instance be used to forward an optocoupler diode (see U2 in Figure 5) in order to latch-off a controller situated on the primary-side of the power supply. The recommended sense resistor value  $R_{OV} = 475 \text{ k}\Omega$ .

### Reference Input

Resistor  $R_{REF}$  at the REFERENCE pin is connected to an internal band gap reference and provides an accurate reference current for internal timing circuits. The recommended value is  $R_{REF} = 127 \text{ k}\Omega$ .

### Quick Charge 2.0 Interface

At power-up CHY101 turns on switch N5 (see Figure 3) in 20 ms or less after the BYPASS pin voltage has reached 4 V. Switch N4 and output switches N1 to N2 remain off. This sets the default 5 V output voltage level. With D+ and D- short-circuited the normal handshake between the AC-DC adapter (DCP) and powered devices (PD) as described in the USB Battery Charging Specification 1.2 can commence. After switch N5 has been turned on, CHY101 starts monitoring the voltage level at D+. If it continuously stays above  $V_{DAT(REF)}$  (typ. 0.325 V) and below  $V_{SEL(REF)}$  (typ. 2 V) for at least 1.25 seconds CHY101 will enter Quick Charge 2.0 operation mode. If the voltage at D+ drops any time below 0.325 V CHY101 resets the 1.25 seconds timer and stays in USB Battery Charging Specification 1.2 compatibility mode with a default output voltage of 5 V.

Once CHY101 has entered Quick Charge 2.0 operation mode, switch N5 will be turned off. Additionally switch N4 is turned on connecting a 19.53 k $\Omega$  pull-down resistor to D-. As soon as the voltage at D- has dropped low (<0.325 V) for at least 1 ms CHY101 starts accepting requests for different AC-DC adapter output voltages by means of applied voltage levels at data lines D+ and D- through the powered device. Table 1 summarizes the output voltage lookup table, corresponding AC-DC adapter output voltages and status of switches N1 to N2.

D+	D-	Output	Switch Status
0.6 V	0.6 V	12 V	N1 = N2 = On
3.3 V	0.6 V	9 V	N1 = On, N2
0.6 V	GND	5 V (default)	N1 = N2 = Off

Table 1. Output Voltage Lookup Table.

At USB cable disconnect the voltage level at D+ is pulled down by resistor  $R_{DAT(LKG)}$  (see Figure 5). Once it drops below 0.325 V CHY101 will turn on switch N5 (thereby short-circuiting D+ and D-) and turns off switches N1 to N4. This sets the default output voltage of 5 V. The recommended value for  $R_{DAT(LKG)} = 390 \text{ k}\Omega$ .

### Design Recommendation

For applications that require the power supply to be tolerant to high ESD stress levels, it is recommended that 1N4148 or equivalent diodes should be connected from  $V_{OUT}$  to D+ and D- (cathode to  $V_{OUT}$  and anode to D+/D-) and also from D+/D- to GND (cathode to D+/D- and anode to GND).

## Absolute Maximum Ratings<sup>2</sup>

BYPASS Pin Voltage .....	-0.3 to 9 V	Storage Temperature .....	-65 °C to 150 °C
REFERENCE Pin Voltage .....	-0.3 to 9 V	Lead Temperature <sup>(1)</sup> .....	260 °C
V1/V2/V3 Pin Voltage .....	-0.3 to 9 V	Notes:	
D+/D- Pin Voltage .....	-0.3 to 5 V	1. 1/16 in. from case for 5 seconds.	
BYPASS Pin Current .....	25 mA	2. The Absolute Maximum Ratings specified may be applied one at a time without causing permanent damage to the product.	
V1/V2 Pin Current .....	0.5 mA	Exposure to Absolute Maximum Rating conditions for extended periods of time may affect product reliability.	
D+/D- Pin Current .....	1 mA		
Operating Junction Temperature.....	-40 °C to +150 °C		
Operating Ambient Temperature.....	-40 °C to 105 °C		

Parameter	Symbol	Conditions SOURCE = 0 V; T <sub>J</sub> = -20 °C to +85 °C (Unless Otherwise Specified)	Min	Typ	Max	Units
<b>Supply, Reference and Protection Functions</b>						
<b>BYPASS Pin Voltage</b>	V <sub>BP</sub>		4	5	6	V
<b>Power-Up Reset Threshold Voltage</b>	V <sub>BP(RESET)</sub>		2.0		3.9	V
<b>BYPASS Pin Source Current</b>	I <sub>BPSC</sub>	V <sub>BP</sub> = 4.3 V, T <sub>J</sub> = 25 °C N1 = N2 = N3 = Off			135	μA
<b>BYPASS Pin Shunt Voltage</b>	V <sub>BP(SHUNT)</sub>	I <sub>BP</sub> = 3 mA	5.7	6	6.3	V
<b>REFERENCE Pin Voltage</b>	V <sub>R</sub>		1.18	1.23	1.28	V
<b>OVP Function</b>						
<b>Output OV Detection Delay Time</b>	t <sub>D(OV)</sub>	I <sub>O</sub> ≥ I <sub>OV(TH)</sub>		50		μs
<b>Output OV Protection Blanking Time</b>	t <sub>B(OV)</sub>		500			ms
<b>V1 Pin OV Trigger Output Current</b>	I <sub>V1(OV)</sub>	V <sub>V1</sub> = V <sub>BP</sub>	3		4.6	mA
<b>Output OV Protection Threshold Current</b>	I <sub>OV(TH)</sub>	Output set to 5 V	9.2	9.7	10.2	μA
		Output set to 9 V	18.2	19.2	20.1	
		Output set to 12 V	25.2	26.5	27.9	
<b>HVDCP Functions</b>						
<b>Data Detect Voltage</b>	V <sub>DAT(REF)</sub>		0.25	0.325	0.4	V
<b>Output Voltage Selection Reference</b>	V <sub>SEL(REF)</sub>		1.8	2	2.2	V
<b>12 V / 20 V Output Inhibit Threshold</b>	V <sub>INH</sub>		V <sub>BP</sub> - 0.6			V
<b>Data Lines Short-Circuit Delay</b>	T <sub>DAT(SHORT)</sub>	V <sub>OUT</sub> ≥ 0.8 V See Figure 5		10	20	ms
<b>D+ High Glitch Filter Time</b>	T <sub>GLITCH(BC) DONE</sub>		1000	1250	1500	ms
<b>Output Voltage Glitch Filter Time</b>	T <sub>GLITCH(V) CHANGE</sub>		20	40	60	ms
<b>D- Pull-Down Resistance</b>	R <sub>DM(DWN)</sub>		14.25	19.53	24.5	kΩ
<b>Switch N1 On-Resistance</b>	R <sub>DS(ON)N1</sub>	I <sub>N1</sub> = 200 μA			300	Ω

<b>Parameter</b>	<b>Symbol</b>	<b>Conditions</b> SOURCE = 0 V; T <sub>j</sub> = -20 °C to +85 °C (Unless Otherwise Specified)	<b>Min</b>	<b>Typ</b>	<b>Max</b>	<b>Units</b>
<b>HVDCP Functions (cont.)</b>						
<b>Switch N2 On-Resistance</b>	R <sub>DS(ON)N2</sub>	I <sub>N2</sub> = 200 μA			300	Ω
<b>Switch N3 On-Resistance</b>	R <sub>DS(ON)N3</sub>	I <sub>N3</sub> = 200 μA			300	Ω
<b>Switch N4 On-Resistance</b>	R <sub>DS(ON)N4</sub>	I <sub>N4</sub> = 200 μA			300	Ω
<b>Switch N5 On-Resistance</b>	R <sub>DS(ON)N5</sub>	I <sub>N5</sub> = 200 μA, V <sub>(D+)</sub> ≤ 3.6 V		20	40	Ω
<b>Data Line Capacitance</b>	C <sub>DCP(PWR)</sub>	See Note A			1	nF

NOTES:

A. Guaranteed by design. Not tested in production.

**SO-8 (D Package)**

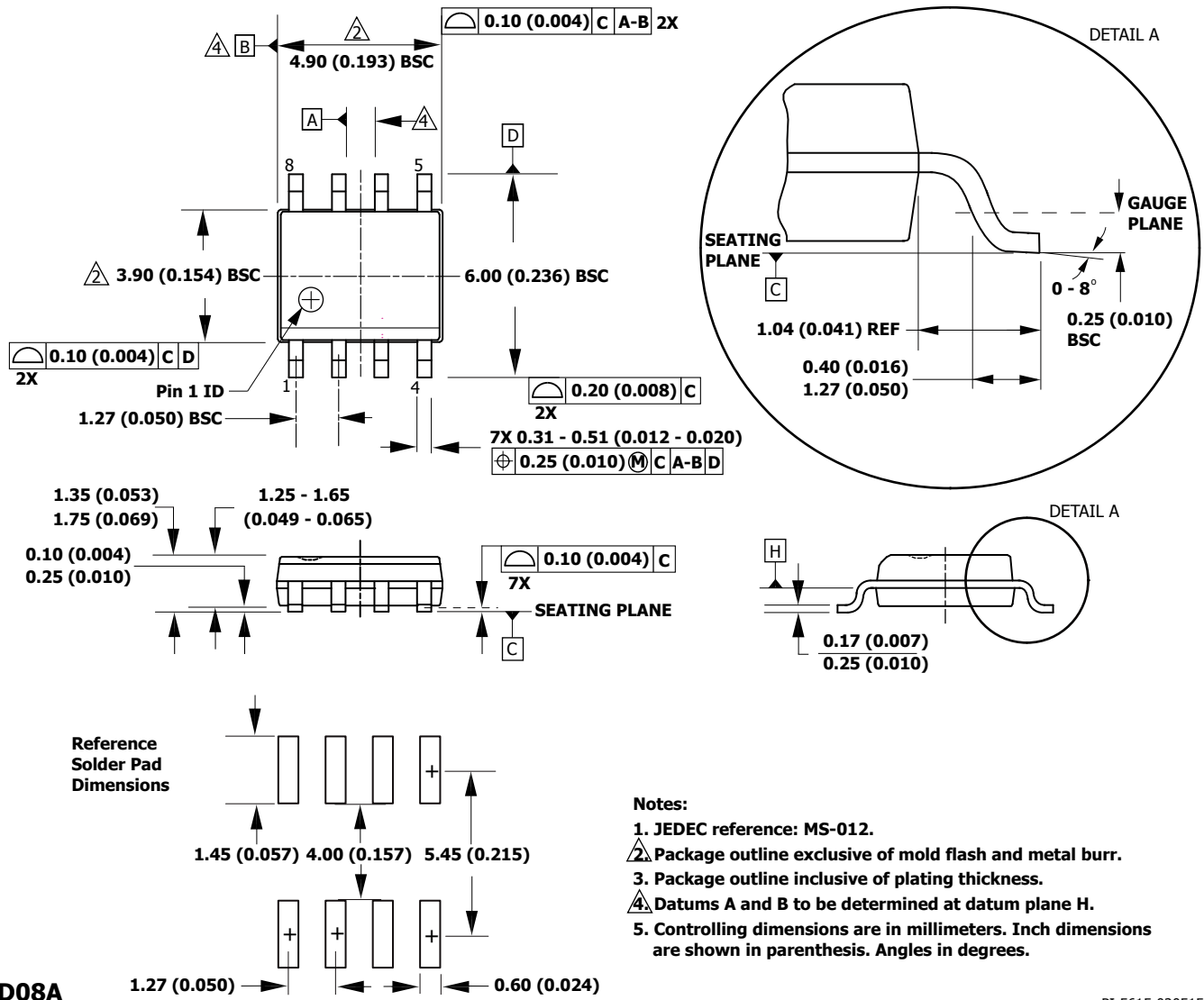

**D08A**

PI-5615-020515

**Part Ordering Information**

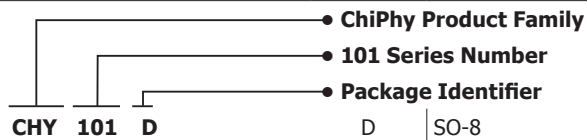

---

Notes

Revision	Notes	Date
A	Initial Release.	02/15

**For the latest updates, visit our website: [www.power.com](http://www.power.com)**

Power Integrations reserves the right to make changes to its products at any time to improve reliability or manufacturability. Power Integrations does not assume any liability arising from the use of any device or circuit described herein. POWER INTEGRATIONS MAKES NO WARRANTY HEREIN AND SPECIFICALLY DISCLAIMS ALL WARRANTIES INCLUDING, WITHOUT LIMITATION, THE IMPLIED WARRANTIES OF MERCHANTABILITY, FITNESS FOR A PARTICULAR PURPOSE, AND NON-INFRINGEMENT OF THIRD PARTY RIGHTS.

**Patent Information**

The products and applications illustrated herein (including transformer construction and circuits external to the products) may be covered by one or more U.S. and foreign patents, or potentially by pending U.S. and foreign patent applications assigned to Power Integrations. A complete list of Power Integrations patents may be found at [www.power.com](http://www.power.com). Power Integrations grants its customers a license under certain patent rights as set forth at <http://www.power.com/ip.htm>.

**Life Support Policy**

POWER INTEGRATIONS PRODUCTS ARE NOT AUTHORIZED FOR USE AS CRITICAL COMPONENTS IN LIFE SUPPORT DEVICES OR SYSTEMS WITHOUT THE EXPRESS WRITTEN APPROVAL OF THE PRESIDENT OF POWER INTEGRATIONS. As used herein:

1. A Life support device or system is one which, (i) is intended for surgical implant into the body, or (ii) supports or sustains life, and (iii) whose failure to perform, when properly used in accordance with instructions for use, can be reasonably expected to result in significant injury or death to the user.
2. A critical component is any component of a life support device or system whose failure to perform can be reasonably expected to cause the failure of the life support device or system, or to affect its safety or effectiveness.

The PI logo, TOPSwitch, TinySwitch, LinkSwitch, LYTSwitch, InnoSwitch, DPA-Switch, PeakSwitch, CAPZero, SENZero, LinkZero, HiperPFS, HiperTFS, HiperLCS, Qspeed, EcoSmart, Clampless, E-Shield, Filterfuse, FluxLink, StakFET, PI Expert and PI FACTS are trademarks of Power Integrations, Inc. Other trademarks are property of their respective companies. ©2015, Power Integrations, Inc.

**Power Integrations Worldwide Sales Support Locations**

**World Headquarters**

5245 Hellyer Avenue  
San Jose, CA 95138, USA.  
Main: +1-408-414-9200  
Customer Service:  
Phone: +1-408-414-9665  
Fax: +1-408-414-9765  
e-mail: [usasales@power.com](mailto:usasales@power.com)

**China (Shanghai)**

Rm 2410, Charity Plaza, No. 88  
North Caoxi Road  
Shanghai, PRC 200030  
Phone: +86-21-6354-6323  
Fax: +86-21-6354-6325  
e-mail: [chinasales@power.com](mailto:chinasales@power.com)

**China (Shenzhen)**

17/F, Hivac Building, No. 2, Keji Nan  
8th Road, Nanshan District,  
Shenzhen, China, 518057  
Phone: +86-755-8672-8689  
Fax: +86-755-8672-8690  
e-mail: [chinasales@power.com](mailto:chinasales@power.com)

**Germany**

Lindwurmstrasse 114  
80337 Munich  
Germany  
Phone: +49-895-527-39110  
Fax: +49-895-527-39200  
e-mail: [eurosales@power.com](mailto:eurosales@power.com)

**India**

#1, 14th Main Road  
Vasanthanagar  
Bangalore-560052 India  
Phone: +91-80-4113-8020  
Fax: +91-80-4113-8023  
e-mail: [indiasales@power.com](mailto:indiasales@power.com)

**Italy**

Via Milanese 20, 3rd. Fl.  
20099 Sesto San Giovanni (MI)  
Italy  
Phone: +39-024-550-8701  
Fax: +39-028-928-6009  
e-mail: [eurosales@power.com](mailto:eurosales@power.com)

**Japan**

Kosei Dai-3 Bldg.  
2-12-11, Shin-Yokohama,  
Kohoku-ku  
Yokohama-shi Kanagwan  
222-0033 Japan  
Phone: +81-45-471-1021  
Fax: +81-45-471-3717  
e-mail: [japansales@power.com](mailto:japansales@power.com)

**Korea**

RM 602, 6FL  
Korea City Air Terminal B/D, 159-6  
Samsung-Dong, Kangnam-Gu,  
Seoul, 135-728, Korea  
Phone: +82-2-2016-6610  
Fax: +82-2-2016-6630  
e-mail: [koreasales@power.com](mailto:koreasales@power.com)

**Singapore**

51 Newton Road  
#19-01/05 Goldhill Plaza  
Singapore, 308900  
Phone: +65-6358-2160  
Fax: +65-6358-2015  
e-mail: [singaporesales@power.com](mailto:singaporesales@power.com)

**Taiwan**

5F, No. 318, Nei Hu Rd., Sec. 1  
Nei Hu Dist.  
Taipei 11493, Taiwan R.O.C.  
Phone: +886-2-2659-4570  
Fax: +886-2-2659-4550  
e-mail: [taiwansales@power.com](mailto:taiwansales@power.com)

**UK**

First Floor, Unit 15, Meadway Court,  
Rutherford Close,  
Stevenage, Herts. SG1 2EF  
United Kingdom  
Phone: +44 (0) 1252-730-141  
Fax: +44 (0) 1252-727-689  
e-mail: [eurosales@power.com](mailto:eurosales@power.com)





## Стандарт Электрон Связь

Мы молодая и активно развивающаяся компания в области поставок электронных компонентов. Мы поставляем электронные компоненты отечественного и импортного производства напрямую от производителей и с крупнейших складов мира.

Благодаря сотрудничеству с мировыми поставщиками мы осуществляем комплексные и плановые поставки широчайшего спектра электронных компонентов.

Собственная эффективная логистика и склад в обеспечивает надежную поставку продукции в точно указанные сроки по всей России.

Мы осуществляем техническую поддержку нашим клиентам и предпродажную проверку качества продукции. На все поставляемые продукты мы предоставляем гарантию .

Осуществляем поставки продукции под контролем ВП МО РФ на предприятия военно-промышленного комплекса России , а также работаем в рамках 275 ФЗ с открытием отдельных счетов в уполномоченном банке. Система менеджмента качества компании соответствует требованиям ГОСТ ISO 9001.

Минимальные сроки поставки, гибкие цены, неограниченный ассортимент и индивидуальный подход к клиентам являются основой для выстраивания долгосрочного и эффективного сотрудничества с предприятиями радиоэлектронной промышленности, предприятиями ВПК и научно-исследовательскими институтами России.

С нами вы становитесь еще успешнее!

### Наши контакты:

**Телефон:** +7 812 627 14 35

**Электронная почта:** [sales@st-electron.ru](mailto:sales@st-electron.ru)

**Адрес:** 198099, Санкт-Петербург,  
Промышленная ул, дом № 19, литера Н,  
помещение 100-Н Офис 331