

LTC6957-3/LTC6957-4

Low Phase Noise, Dual CMOS Output Buffer/Driver/Logic Converter

DESCRIPTION

Demonstration Circuit 1766A features the [LTC®6957-3/LTC6957-4](#), a low phase noise, dual CMOS output buffer/driver/logic converter.

The DC1766A provides SMA connectors for the differential inputs and the CMOS outputs. The inputs are terminated to on-board 50Ω resistors and the outputs present similar impedance. The DC1766A allows the user to take advantage of the shutdown and bandwidth selection features of the LTC6957. The DC1766A can operate with a single-ended or

differential sine wave or square-wave input signal. Supply the DC1766A with 3.3V and it is ready to function. Or, the output can be powered from a lower voltage supply if a lower voltage CMOS driver is desired. The DC1766A gives extra component population options to make it compatible with different logic signal types.

Design files for this circuit board are available at <http://www.linear.com/demo>

LT, LT, LTC, LTM, Linear Technology and the Linear logo are registered trademarks of Linear Technology Corporation. All other trademarks are the property of their respective owners.

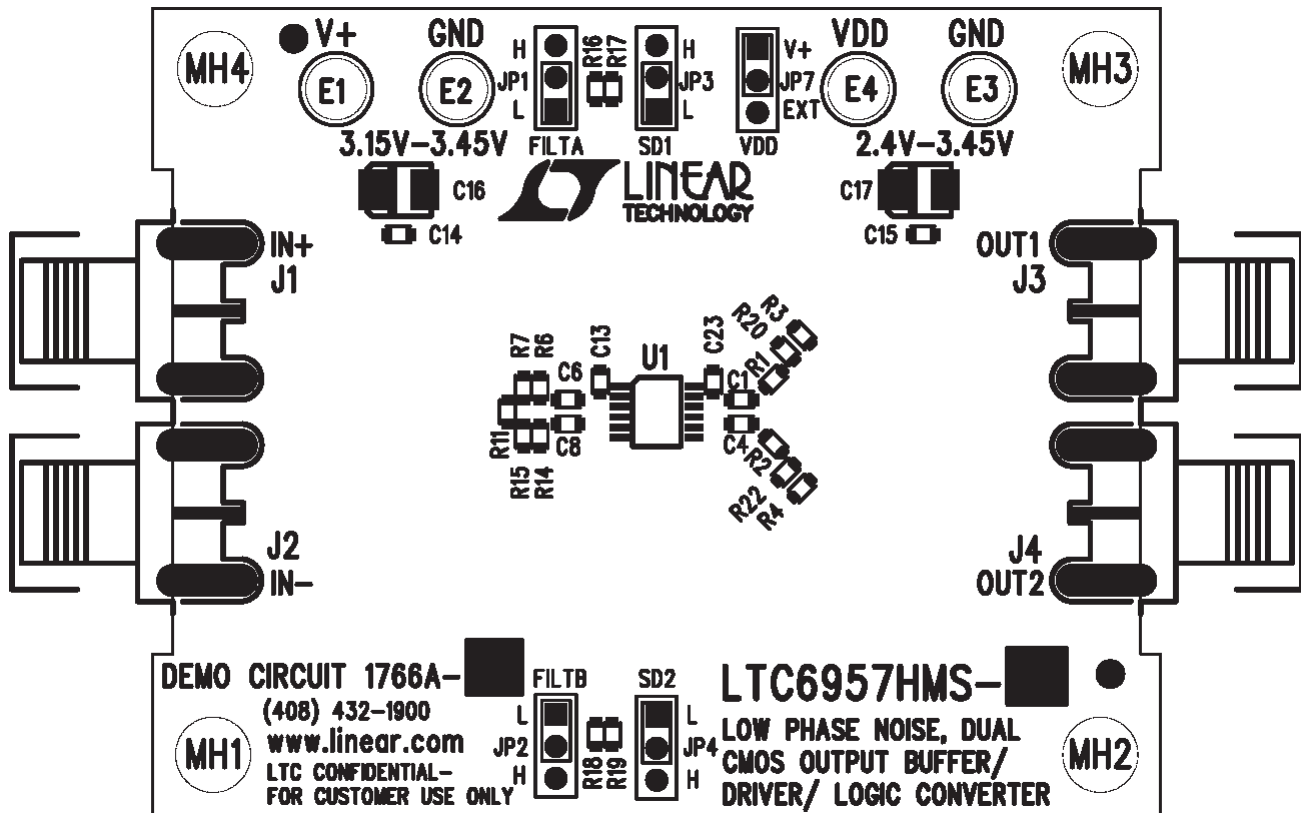

Figure 1. DC1766A Inputs and Outputs

QUICK START PROCEDURE

The DC1766A is very straightforward to operate. Refer to Figure 1 for the following discussion.

DC1766A Configuration

1. Apply a low-noise and low-spurious 3.3V supply between the V+ (E1) and GND (E2) turrets.
2. Make sure that jumper VDD (JP7) is at the V+ position if 3.3V CMOS output operation is desired. Otherwise, apply a voltage that is between 2.4V and 3.3V between the VDD (E4) and GND (E3) turrets, and move jumper VDD (JP7) to EXT position to operate the CMOS outputs at the voltage level supplied at the VDD turret.
3. Connect a low phase noise (or jitter) single-ended or differential input signal to IN+ (J1) and/or IN- (J2) SMA connectors. Refer to the LTC6957 data sheet for appropriate input signal types and levels.
4. Connect either of the outputs (OUT1, J3 or OUT2, J4) to a high-speed scope, spectrum analyzer or a signal analyzer to start the evaluation of the LTC6957.

NOTE: The CMOS outputs of the DC1766A are AC-coupled and attenuated through two 100 Ω resistors as shown in the DC1766A schematic diagram to present a 50 Ω source impedance appropriate to connect to a 50 Ω input impedance instrument.

5. Configure the input bandwidth of the LTC6957 with the use of FILTA (JP1) and FILTB (JP2) jumpers. Follow the instructions given in the LTC6957 data sheet to choose the correct bandwidth given an input signal.
6. Shut down an unused output by using jumper SD1 (JP3) to shutdown OUT1 or jumper SD2 (JP4) to shutdown OUT2.

DC1766A Reconfiguration

The DC1766A is flexible and allows the connectivity of a variety of input and output signal types. The DC1766A is configured as shown in the schematic diagram. However, the DC1766A allows the installation of different input and output configurations to adapt to a variety of logic signals. Refer to the Applications Information section of the LTC6957 data sheet for all possible connectivity options that can be implemented by modifying the DC1766A.

ASSEMBLY OPTIONS

Table 1. DC1766A Assembly Options

ASSEMBLY VERSION	PART NUMBER	OUTPUT TYPE
DC1766A-A	LTC6957HMS-3	In-Phase CMOS
DC1766A-B	LTC6957HMS-4	Complementary CMOS

LAYOUT TOP LAYER

The top metal layer of the DC1766A is shown here as an example of good PCB layout for the LTC6957-3/LTC6957-4.

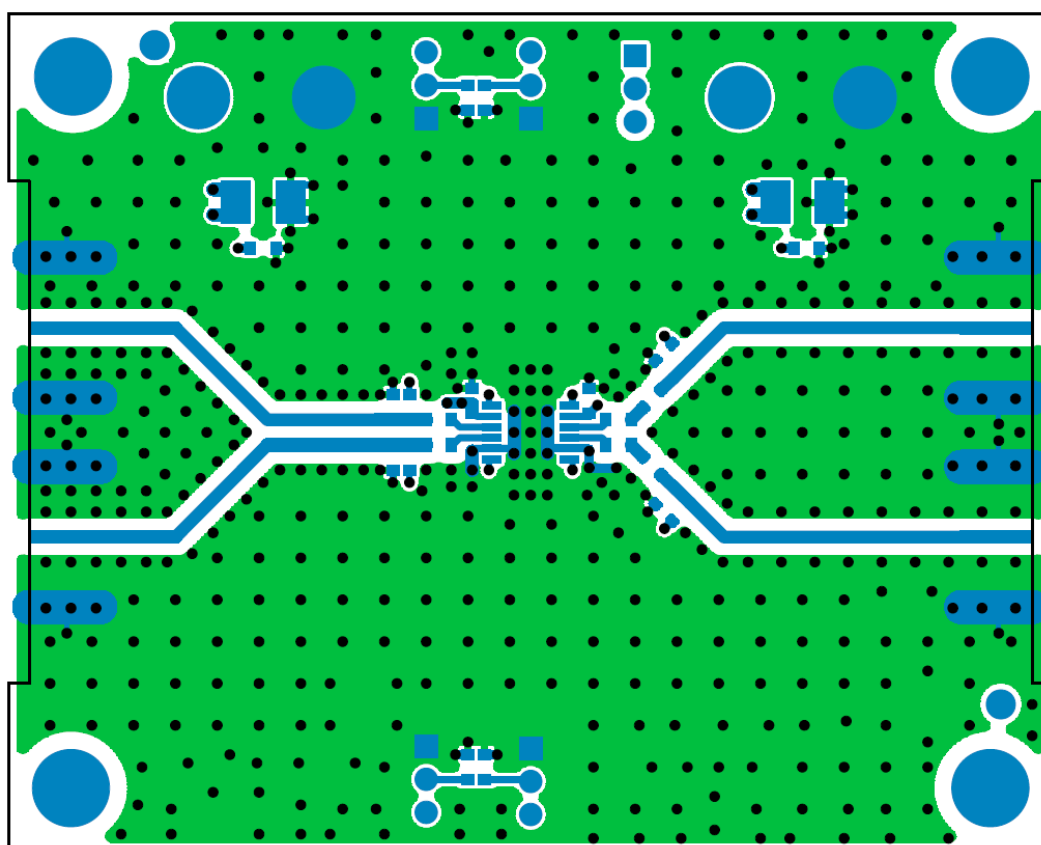

DEMO MANUAL DC1766A

PARTS LIST

ITEM	QTY	REFERENCE	PART DESCRIPTION	MANUFACTURER/PART NUMBER
DC1766A General BOM				
1	4	C1, C4, C6, C8	CAP., X7R, 0.01µF 50V 10%, 0603	NIC, NMC0603X7R103K50TRP
2	2	C13, C23	CAP., X7R, 0.1µF 50V 10%, 0603	TDK, C1608X7R1H104K
3	2	C14, C15	CAP., X5R, 1µF 25V 10%, 0603	TDK, C1608X5R1E105K
4	2	C16, C17	CAP., TANT, 22µF 10V, 3528	AVX, TPSB226K010R0400
5	4	E1, E2, E3, E4	TESTPOINT, TURRET 0.094"	MILLMAX, 2501-2-00-80-00-00-07-0
6	5	JP1, JP2, JP3, JP4, JP7	JMP, HD1X3-079	SAMTEC, TMM-103-02-L-S
7	4	J1, J2, J3, J4	CONN., SMA 50Ω EDGE-LAUNCH	E.F. JOHNSON, 142-0701-851
8	4	R1, R2, R20, R22	RES., CHIP, 100Ω 1% 0603	VISHAY, CRCW0603100RFKEA
9	0	R3, R4, R6, R11, R14	RES., OPT 0603	OPT
10	2	R7, R15	RES., CHIP, 49.9Ω 1% 0603	VISHAY, CRCW060349R9FKEA
11	4	R16, R17, R18, R19	RES., CHIP, 330k 1% 0603	VISHAY, CRCW0603330KFKEA
12	4		STAND-OFF, NYLON 0.500	KEYSTONE, 8833 (SNAP ON)
13	5		SHUNT, .079" CENTER	SAMTEC, 2SN-BK-G
DC1766A-A				
1	1		DC1766A General BOM	DC1766A
2	1	U1	IC, LTC6957HMS-3, MS12	LINEAR TECH., LTC6957HMS-3
DC1766A-B				
1	1		DC1766A GENERAL BOM	DC1766A
2	1	U1	IC, LTC6957HMS-4, MS12	LINEAR TECH., LTC6957HMS-4

SCHEMATIC DIAGRAM

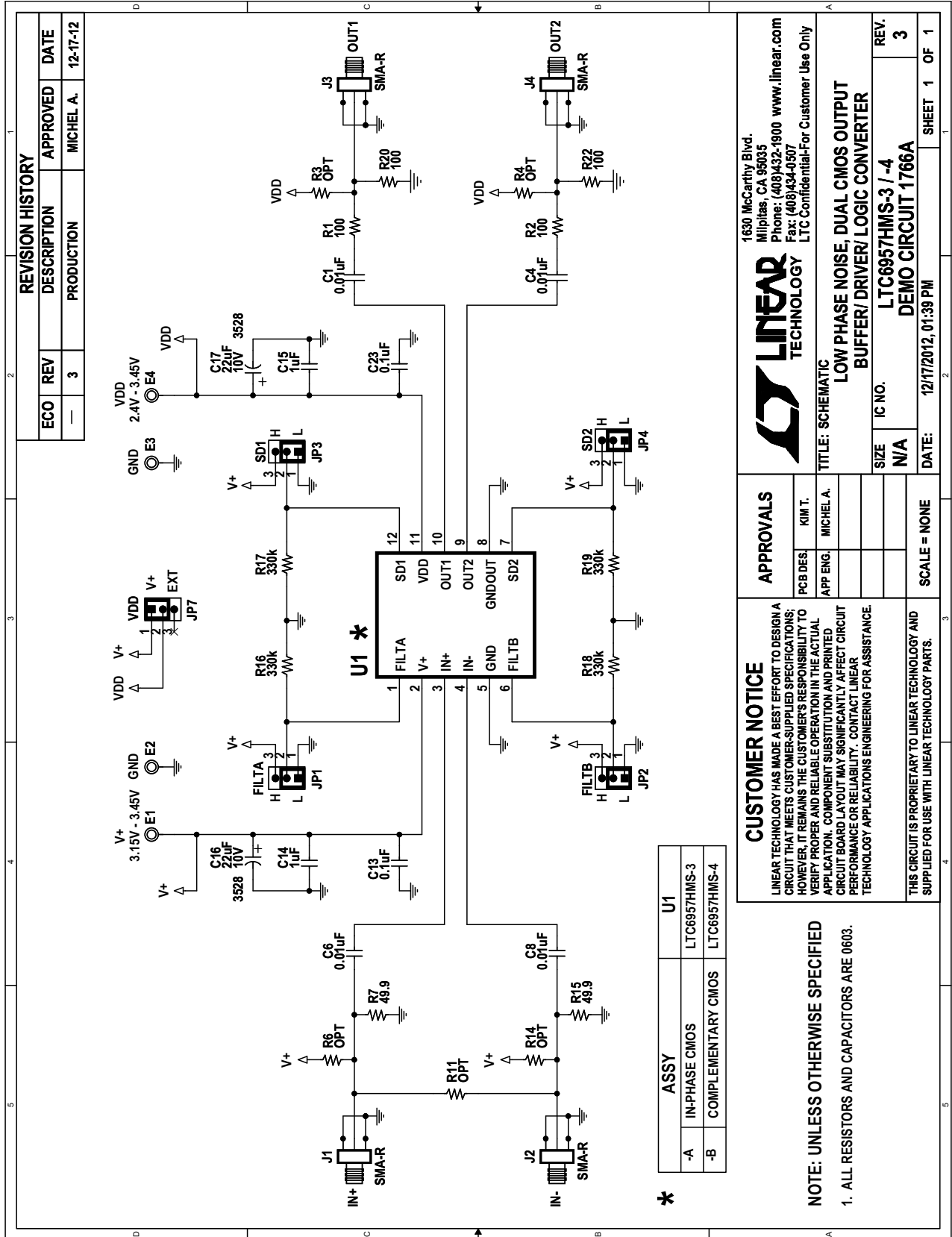

REVISION HISTORY				
ECO	REV	DESCRIPTION	APPROVED	DATE
—	3	PRODUCTION	MICHEL A.	12-17-12

LINEAR TECHNOLOGY
 1630 McCarthy Blvd.
 Milpitas, CA 95035
 Phone: (408)432-1900 www.linear.com
 Fax: (408)434-0507
 LTC Confidential-For Customer Use Only

TITLE: SCHEMATIC
LOW PHASE NOISE, DUAL CMOS OUTPUT BUFFER/ DRIVER/ LOGIC CONVERTER

SIZE: N/A IC NO.: LTC6957HMS-3 / -4 REV.: 3
 DATE: 12/17/2012, 01:39 PM SHEET 1 OF 1

APPROVALS	
PCB DES	KIM T.
APP ENG.	MICHEL A.
SCALE = NONE	

CUSTOMER NOTICE
 LINEAR TECHNOLOGY HAS MADE A BEST EFFORT TO DESIGN A CIRCUIT THAT MEETS CUSTOMER-SUPPLIED SPECIFICATIONS; HOWEVER, IT REMAINS THE CUSTOMER'S RESPONSIBILITY TO VERIFY PROPER AND RELIABLE OPERATION IN THE ACTUAL APPLICATION. COMPONENT SUBSTITUTION AND PRINTED CIRCUIT BOARD LAYOUT MAY SIGNIFICANTLY AFFECT CIRCUIT PERFORMANCE OR RELIABILITY. CONTACT LINEAR TECHNOLOGY APPLICATIONS ENGINEERING FOR ASSISTANCE.

THIS CIRCUIT IS PROPRIETARY TO LINEAR TECHNOLOGY AND SUPPLIED FOR USE WITH LINEAR TECHNOLOGY PARTS.

U1	
-A	IN-PHASE CMOS
-B	COMPLEMENTARY CMOS

NOTE: UNLESS OTHERWISE SPECIFIED
 1. ALL RESISTORS AND CAPACITORS ARE 0603.



Information furnished by Linear Technology Corporation is believed to be accurate and reliable. However, no responsibility is assumed for its use. Linear Technology Corporation makes no representation that the interconnection of its circuits as described herein will not infringe on existing patent rights.

DEMO MANUAL DC1766A

DEMONSTRATION BOARD IMPORTANT NOTICE

Linear Technology Corporation (LTC) provides the enclosed product(s) under the following **AS IS** conditions:

This demonstration board (DEMO BOARD) kit being sold or provided by Linear Technology is intended for use for **ENGINEERING DEVELOPMENT OR EVALUATION PURPOSES ONLY** and is not provided by LTC for commercial use. As such, the DEMO BOARD herein may not be complete in terms of required design-, marketing-, and/or manufacturing-related protective considerations, including but not limited to product safety measures typically found in finished commercial goods. As a prototype, this product does not fall within the scope of the European Union directive on electromagnetic compatibility and therefore may or may not meet the technical requirements of the directive, or other regulations.

If this evaluation kit does not meet the specifications recited in the DEMO BOARD manual the kit may be returned within 30 days from the date of delivery for a full refund. **THE FOREGOING WARRANTY IS THE EXCLUSIVE WARRANTY MADE BY THE SELLER TO BUYER AND IS IN LIEU OF ALL OTHER WARRANTIES, EXPRESSED, IMPLIED, OR STATUTORY, INCLUDING ANY WARRANTY OF MERCHANTABILITY OR FITNESS FOR ANY PARTICULAR PURPOSE. EXCEPT TO THE EXTENT OF THIS INDEMNITY, NEITHER PARTY SHALL BE LIABLE TO THE OTHER FOR ANY INDIRECT, SPECIAL, INCIDENTAL, OR CONSEQUENTIAL DAMAGES.**

The user assumes all responsibility and liability for proper and safe handling of the goods. Further, the user releases LTC from all claims arising from the handling or use of the goods. Due to the open construction of the product, it is the user's responsibility to take any and all appropriate precautions with regard to electrostatic discharge. Also be aware that the products herein may not be regulatory compliant or agency certified (FCC, UL, CE, etc.).

No License is granted under any patent right or other intellectual property whatsoever. **LTC assumes no liability for applications assistance, customer product design, software performance, or infringement of patents or any other intellectual property rights of any kind.**

LTC currently services a variety of customers for products around the world, and therefore this transaction **is not exclusive**.

Please read the DEMO BOARD manual prior to handling the product. Persons handling this product must have electronics training and observe good laboratory practice standards. **Common sense is encouraged.**

This notice contains important safety information about temperatures and voltages. For further safety concerns, please contact a LTC application engineer.

Mailing Address:

Linear Technology
1630 McCarthy Blvd.
Milpitas, CA 95035

Copyright © 2004, Linear Technology Corporation



Стандарт Электрон Связь

Мы молодая и активно развивающаяся компания в области поставок электронных компонентов. Мы поставляем электронные компоненты отечественного и импортного производства напрямую от производителей и с крупнейших складов мира.

Благодаря сотрудничеству с мировыми поставщиками мы осуществляем комплексные и плановые поставки широчайшего спектра электронных компонентов.

Собственная эффективная логистика и склад в обеспечивает надежную поставку продукции в точно указанные сроки по всей России.

Мы осуществляем техническую поддержку нашим клиентам и предпродажную проверку качества продукции. На все поставляемые продукты мы предоставляем гарантию .

Осуществляем поставки продукции под контролем ВП МО РФ на предприятия военно-промышленного комплекса России , а также работаем в рамках 275 ФЗ с открытием отдельных счетов в уполномоченном банке. Система менеджмента качества компании соответствует требованиям ГОСТ ISO 9001.

Минимальные сроки поставки, гибкие цены, неограниченный ассортимент и индивидуальный подход к клиентам являются основой для выстраивания долгосрочного и эффективного сотрудничества с предприятиями радиоэлектронной промышленности, предприятиями ВПК и научно-исследовательскими институтами России.

С нами вы становитесь еще успешнее!

Наши контакты:

Телефон: +7 812 627 14 35

Электронная почта: sales@st-electron.ru

Адрес: 198099, Санкт-Петербург,
Промышленная ул, дом № 19, литера Н,
помещение 100-Н Офис 331