

## UDP SiM3U1xx MCU CARD USER'S GUIDE

### 1. Introduction

The Unified Development Platform (UDP) provides a development and demonstration platform for Silicon Laboratories microcontrollers, short-range wireless devices, and software tools, including the Silicon Laboratories Integrated Development Environment (IDE).

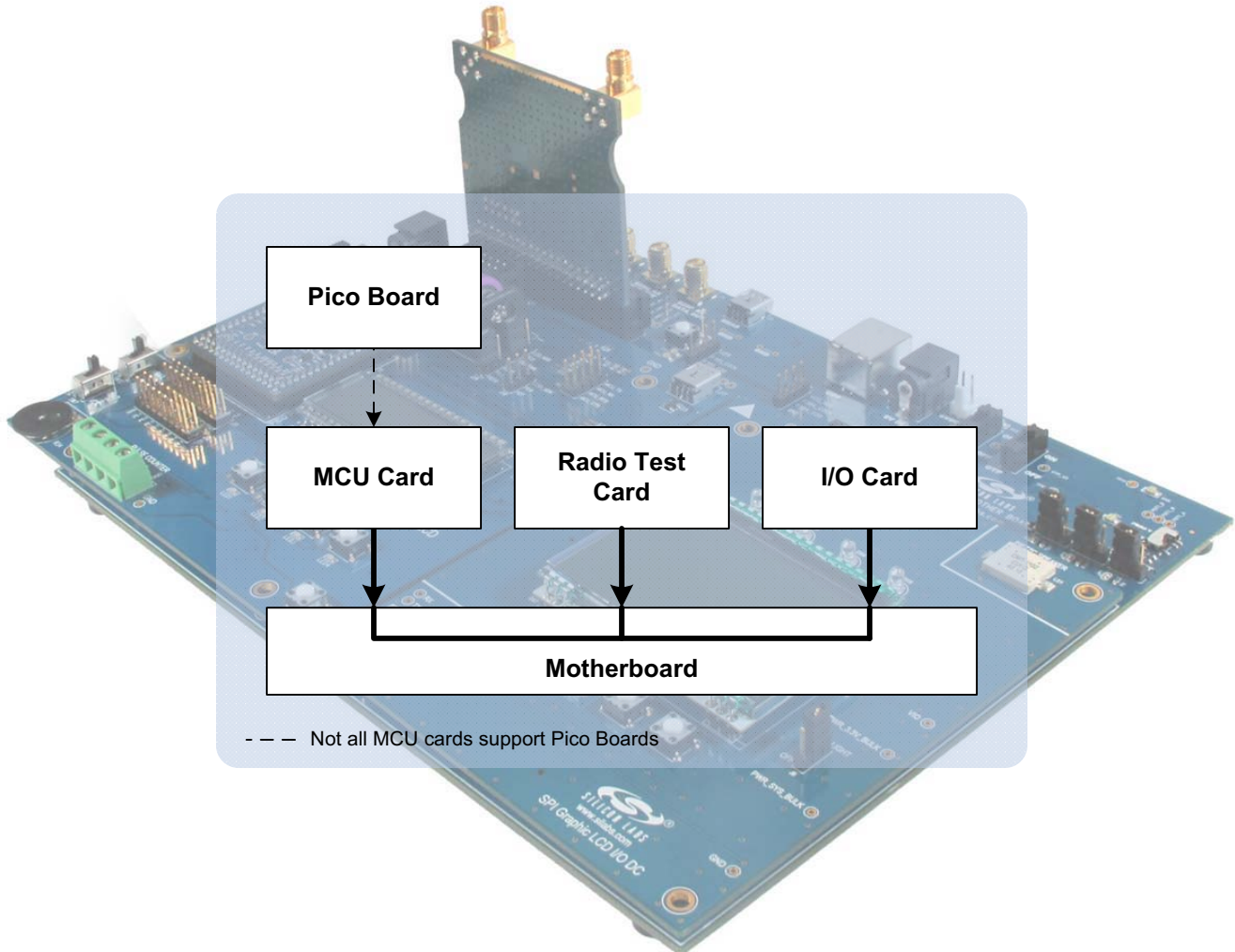

Figure 1. Unified Development Platform Block Diagram

## 2. Relevant Documents

This document provides a hardware overview for the Unified Development Platform (UDP) system SiM3U1xx MCU card. Additional information on the UDP system can be found in the documents listed in this section.

### 2.1. Motherboard User's Guide

The UDP Motherboard User's Guide contains information on the motherboard features and can be found at [www.silabs.com/udp](http://www.silabs.com/udp).

### 2.2. Card User's Guides

The UDP MCU, I/O, and radio test card user's guides can be found at [www.silabs.com/udp](http://www.silabs.com/udp).

## 3. Hardware Setup

### 3.1. Using the MCU Card Alone

Refer to Figure 2 for a diagram of the hardware configuration when using the MCU card without a UDP motherboard.

1. Connect the USB Debug Adapter to the 10-pin debug connector (J31) on the MCU card with the 10-pin ribbon cable.
2. Connect one end of the USB cable to the USB connector on the USB Debug Adapter.
3. Connect the other end of the USB cable to a USB Port on the PC.
4. Move the SW5 System Power Select switch to the upper USB position.
5. Verify that the USB (J14), VDD (J15), and VIO (J17) Imeasure jumpers are all populated.
6. Verify that the VIOHD Selection jumper (J18) is in the upper position between VIO and VIOHD.
7. Connect one end of the mini USB cable to a USB port on the PC.
8. Connect the other end of the mini USB cable to the USB port on the board labeled Device USB (J13).

#### Notes:

- Use the Reset button in the IDE to reset the target when connected using a USB Debug Adapter.
- Remove power from the MCU card and the USB Debug Adapter before connecting or disconnecting the ribbon cable from the MCU card. Connecting or disconnecting the cable when the devices have power can damage the device and/or the USB Debug Adapter.

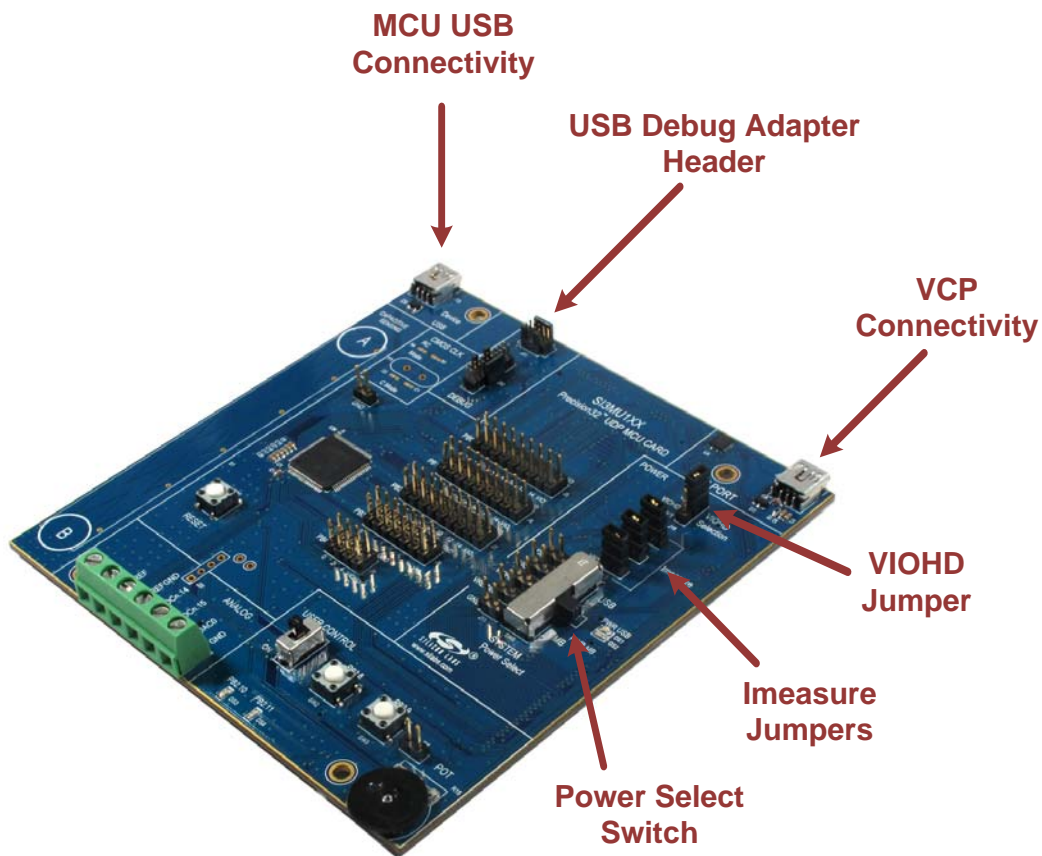

Figure 2. Hardware Setup using the MCU Card Alone

# UDP SiM3U1xx

## 3.2. Using the MCU Card with the UDP Motherboard

Refer to Figure 3 for a diagram of the hardware configuration when using the MCU card with a UDP motherboard.

1. Connect the MCU card to the UDP motherboard slot.
2. (Optional) Connect an I/O card to the UDP motherboard slot.
3. (Optional) Connect a radio test card to the radio test card slot in the UDP motherboard.
4. (Optional) Connect an EZLink card to the EZLink card slot in the UDP motherboard.
5. Connect the USB Debug Adapter to the 10-pin debug connector (J31) on the MCU card with the 10-pin ribbon cable.
6. Connect one end of the USB cable to the USB connector on the USB Debug Adapter.
7. Connect the other end of the USB cable to a USB Port on the PC.
8. Move the SW5 System Power Select switch to the lower MB position.
9. Verify that the USB (J14), VDD (J15), and VIO (J17) Imeasure jumpers are all populated.
10. Verify that the VIOHD Selection jumper (J18) is in the upper position between VIO and VIOHD.
11. Connect the ac/dc power adapter to power jack J20 on the UDP motherboard. The board can also be powered from the J16 USB, J1 mini USB connectors, or J11 battery connector socket.
12. Move the S3 power switch on the UDP motherboard to the ON position.
13. Update the motherboard firmware as described in Section 3.4.

### Notes:

- Use the Reset button in the IDE to reset the target when connected using a USB Debug Adapter.
- Remove power from the target board and the USB Debug Adapter before connecting or disconnecting the ribbon cable from the target board. Connecting or disconnecting the cable when the devices have power can damage the device and/or the USB Debug Adapter.
- The MCU card can be used alone without the motherboard. However, the motherboard must be powered if an MCU card is connected.

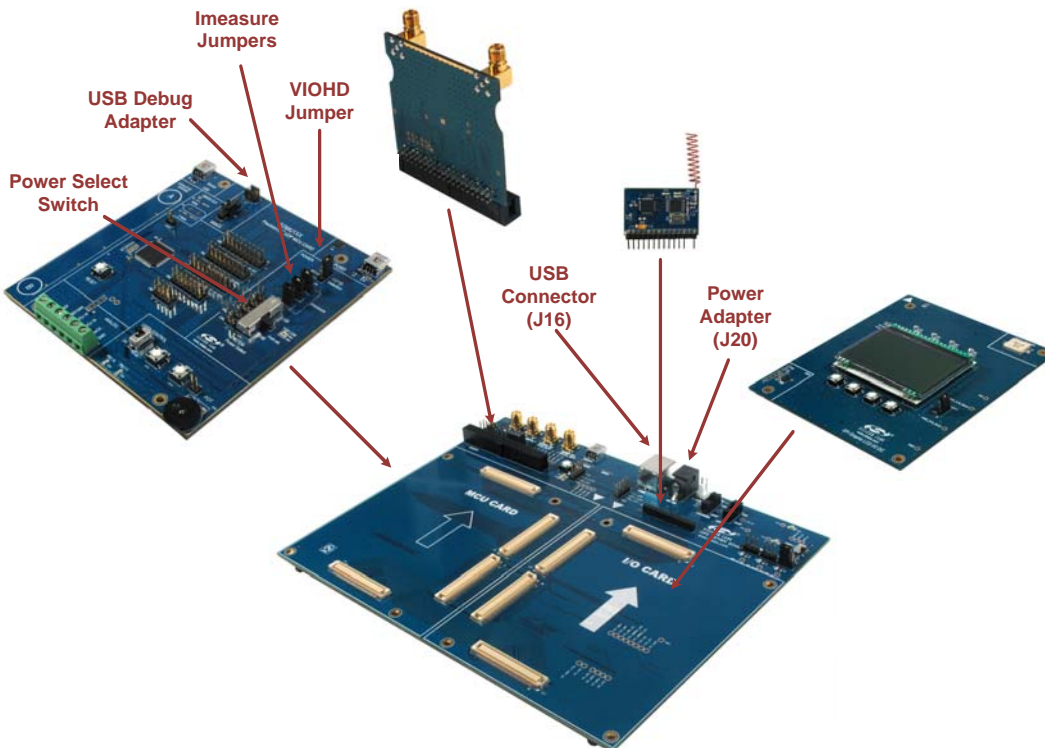

Figure 3. Hardware Setup using the Unified Development Platform

### 3.3. CP210x USB to UART VCP Driver Installation

The MCU card includes a Silicon Labs CP210x USB-to-Dual-UART Bridge Controller. Device drivers for the CP210x need to be installed before the PC software can communicate with the MCU through the UART interface. If the "Install CP210x Drivers" option is selected during installation, a driver "unpacker" utility will launch.

1. Follow the steps to copy the driver files to the desired location. The default directory is *C:\SiLabsMCU\CP210x*.
2. The final window will give an option to install the driver on the target system. Select the "Launch the CP210x VCP Driver Installer" option if you are ready to install the driver.
3. If selected, the driver installer will now launch, providing an option to specify the driver installation location. After pressing the "Install" button, the installer will search your system for copies of previously installed CP210x Virtual COM Port drivers. It will let you know when your system is up to date. The driver files included in this installation have been certified by Microsoft.
4. If the "Launch the CP210x VCP Driver Installer" option was not selected in step 3, the installer can be found in the location specified in step 2, by default *C:\SiLabsMCU\CP210x\Windows\_2K\_XP\_S2K3\_Vista*. At this location, run *CP210xVCPInstaller.exe*.
5. To complete the installation process, connect the included USB cable between the host computer and the COM PORT USB connector (J10) on the MCU Card. Windows will automatically finish the driver installation. Information windows will pop up from the taskbar to show the installation progress.
6. If needed, the driver files can be uninstalled by selecting "Silicon Labs CP210x USB to UART Bridge Driver Removal" option in the "Add or Remove Programs" window.

### 3.4. Updating the UDP Motherboard Firmware

To ensure the UDP Motherboard supports the SiM3U1xx MCU card, run the UDP Motherboard Firmware Update Utility shown in Figure 4. This utility can be downloaded from [www.silabs.com/udp](http://www.silabs.com/udp).

1. Connect the UDP motherboard to a PC using a regular USB cable connected to the UDS connector (J16).
2. Run the utility.
3. Select the desired motherboard if more than one is connected to the PC.
4. Press the **Update Selected Device** button.

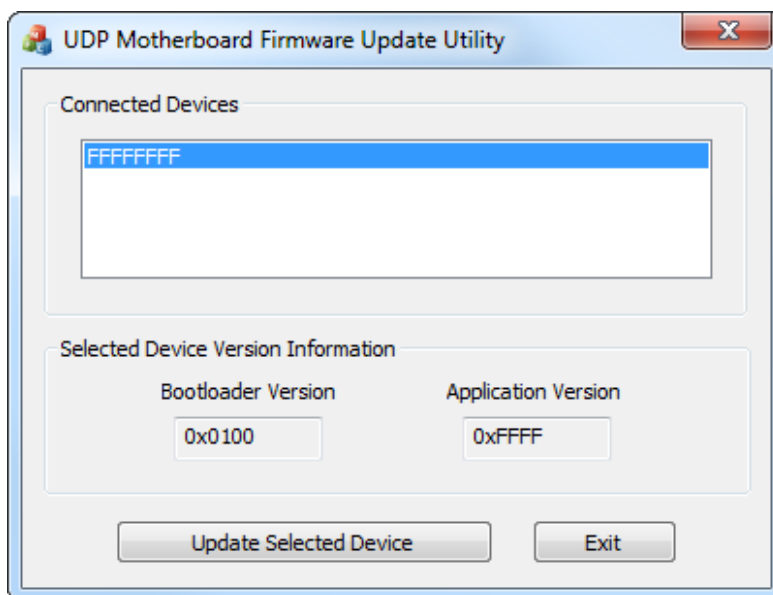

Figure 4. UDP Motherboard Firmware Update Utility



## 4. UDP SiM3U1xx MCU Card Overview

The SiM3U1xx MCU card enables application development on the SiM3U1xx MCU. The card connects to the MCU Card expansion slot on the UDP motherboard and provides complete access to the MCU resources. Each expansion board has a unique ID that can be read out of an EEPROM or MCU on the board, which enables software tools to recognize the connected hardware and automatically select the appropriate firmware image. The target MCU card can also be detached from the UDP and used alone as a development or demonstration tool.

Figure 5 shows the SiM3U1xx MCU card.

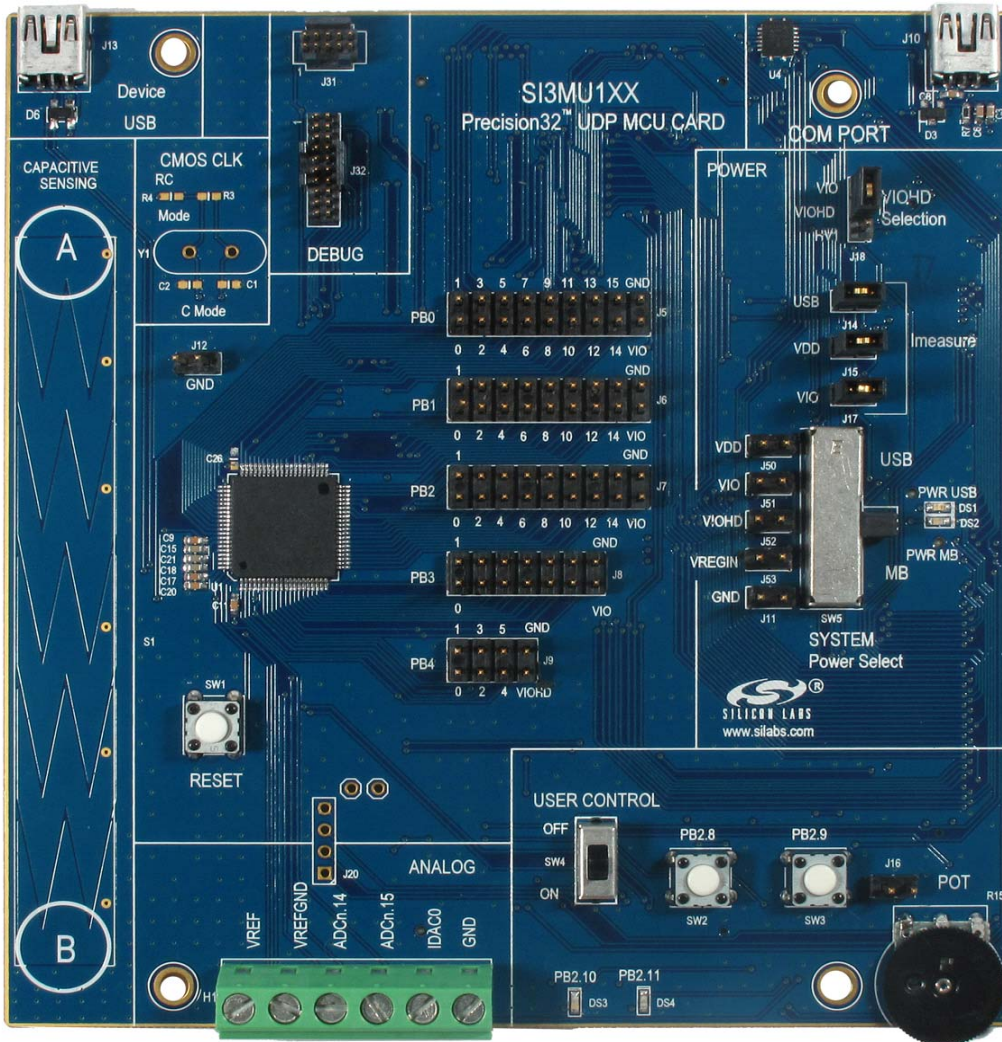

Figure 5. UDP SiM3U1xx MCU Card

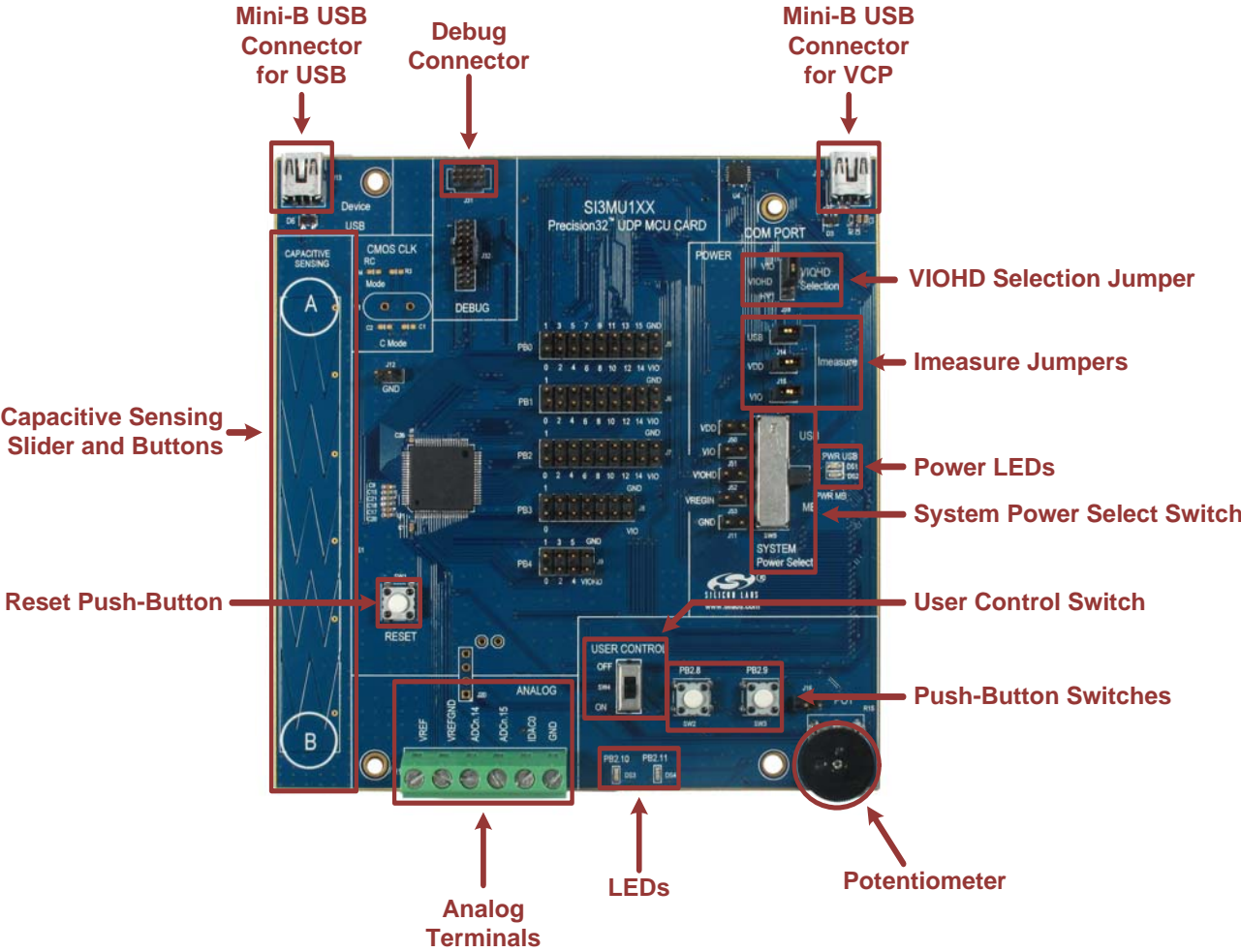

Figure 6. UDP SiM3U1xx MCU Card Features

4.1. Push-Button Switches and LEDs (SW2, SW3, DS3, DS4)

The UDP SiM3U1xx MCU card has two push-button switches and two LEDs. The two switches connect to PB2.8 and PB2.9. The switches are normally open and pull the pin voltage to ground when pressed.

Port pins PB2.10 and PB2.11 also connect to two LEDs: DS3 and DS4. The LEDs connect to VIO through a current limiting resistor.

When using PB2.8 and PB2.9 as switches and PB2.10 and PB2.11 as LEDs, the User Control switch (SW4) must be in the ON position.

## 4.2. Analog Terminals (H1)

Several of the SiM3U1xx port pins used for analog functions are connected to the H1 terminal block. Refer to Table 1 for the H1 terminal block connections.

**Table 1. Terminal Block Pin Descriptions (H1)**

Pin	I/O
1	PB0.12 / VREF
2	PB0.11 / VREFGND
3	PB1.5 / ADCn.14
4	PB1.6 / ADCn.15
5	PB0.13 / IDAC0
6	GND

## 4.3. User Control Switch (SW4)

The User Control Switch enables and disables the User Control portion of the board. When in the ON position, various GPIO pins are connected to the push-button switches, LEDs, and potentiometer. When in the OFF position, the GPIO pins are disconnected from the hardware in the User Control portion of the board. The OFF selection should be used if another I/O board is connected to the MCU Card via a UDP motherboard or if the GPIO pins are needed for different functions. Table 2 shows a list of the GPIO pins that are controlled by the User Control Switch.

**Table 2. User Controlled GPIO Pins**

GPIO Pin	User Control Function
PB1.5	Potentiometer
PB2.8	Push-Button Switch (SW2)
PB2.9	Push-Button Switch (SW3)
PB2.10	Red LED (DS3)
PB2.11	Yellow LED (DS4)
PB2.12	Potentiometer Bias

## 4.4. Potentiometer (R15)

The potentiometer is available on PB1.5. To use the potentiometer, install a shorting block on J16 to connect PB1.5 to POT. To facilitate a low-power potentiometer, PB2.12 connects to bottom of the potentiometer as a potentiometer enable. Drive PB2.12 low to enable the potentiometer. The User Control switch must be in the ON position to use the potentiometer.

## 4.5. System Power Select Switch (SW5)

The MCU card has two power supply options: USB power or UDP motherboard power. The System Power Select Switch is used to select between the two. If the MCU card is used without the UDP Motherboard, this switch should be placed in the USB position. While in the USB position, the part can be powered by USB through the mini-B USB connector (J13) labeled "Device USB". To power the MCU with a DC power supply, the power supply can be attached to the VDD header (J50) or the VREGIN header (J53) to the left of the System Power Select Switch. In either of these configurations, the System Power Select should be in the USB position.



## 4.6. Power LEDs (DS1, DS2)

The two power LEDs provide visual feedback when the board is powered. When the System Power Select Switch is in the USB position, the PWR USB LED (DS1) will turn on when the device is powered over USB or by connecting a power supply to any power header on the board. When the System Power Select Switch is in the MB position, the PWR MB LED (DS2) will turn on when the device is powered by a UDP Motherboard.

## 4.7. Imeasure Jumpers (J14, J15, J17)

The USB (J14), VDD (J15), and VIO (J17) Imeasure jumpers allow for easy access to measure the supply current of the MCU. The shorting blocks for these headers are populated by default. To measure the supply current, remove the corresponding shorting block and connect a current measurement device across the unpopulated header.

## 4.8. VIOHD Selection Jumper (J18)

The VIOHD jumper allows for the VIOHD pin on the MCU to be connected to the VIO power supply, the HV1 signal from the UDP Motherboard, or to an external power supply. The HV1 option is only available if the MCU is connected to a UDP Motherboard. To power from an external supply, remove the shorting block and connect the supply to pin 2 of the header.

## 4.9. UART VCP Connection Options (J10)

The MCU card features a USB virtual COM port (VCP) UART connection via the mini-B USB connector (J10) labeled “COM PORT”. The VCP connection uses the CP210x USB-to-UART bridge chip. The GPIO pins connected to the CP210x device can be enable or disabled when connected to a UDP Motherboard as necessary. When the MCU card is not connected to the UDP Motherboard, the TX, RX, CTS, and RTS signals are all connected to the CP210x device. Table 3 shows the GPIO pins that are routed to the CP210x or UDP Motherboard.

**Table 3. CP210x Controlled GPIO Pins**

GPIO Pin	User Control Function
PB1.12	RX
PB1.13	TX
PB1.14	CTS
PB1.15	RTS

## 4.10. USB Connection Options (J13)

The MCU card features a USB connection via the mini-B USB connector (J13) labeled “Device USB”. The USB connector is provided to facilitate connections to the USB interface on the SiM3U1xx. Table 4 shows the J13 pin definitions.

**Table 4. USB Connector Pin Descriptions**

Pin	User Control Function
1	VBUS
2	D-
3	D+
4	GND

## 4.11. Debug Header (J31)

The mini 10-pin debug header supports the Silicon Labs USB Debug Adapter. This connector provides a Serial Wire (SW) debug connection to the SiM3U1xx on the MCU card.

## 4.12. Capacitive Sensing Button and Slider (S1)

Two capacitive sensing buttons and one slider are included on the MCU card. Six GPIO pins are connected to the slider and can be used to implement up to two buttons or a slider. Table 5 shows the J13 pin definitions. The GPIO pins are connected to the slider in ascending order from the location labeled “A” to the location labeled “B” on the MCU card.

**Table 5. Capacitive Sensing GPIO Connections**

Location	Pin
A	PB1.7
—	PB1.8
—	PB0.4
—	PB0.3
—	PB0.2
B	PB0.1

## 4.13. Reset Button (SW1)

The reset push-button switch is in the lower-left corner. Pushing this button will always reset the MCU. Note that pushing this button while the IDE is connected to the MCU will result in IDE disconnecting from the target.

## 4.14. Port Pin Headers (J5-J9)

All of the MCU port pins are available on the 0.100-inch headers on the MCU card. Some of these port pins are shared with other functions on the board. For example, PB0.9 and PB0.10 are both used by the external RTC. Several GPIO pins are connected to circuits in the User Control portion of the board as well. To disconnect these GPIO pins from the additional circuits, place the User Control switch in the OFF position. PB1.12, PB1.13, PB1.14, and PB1.15 are either routed to the CP210x device or to the UDP Motherboard. For more information on the GPIO pins used by the CP210x or UART interface, see Section 4.9.

## 4.15. MCU Card Default and Optional Connections

The MCU card has many default and optional connections for use with different I/O cards and the UDP motherboard. The default connections are via shorting jumpers. The shorting jumpers are a 603 resistor footprint with a cut trace between pads. To disconnect, cut the trace with a sharp utility knife. To reconnect, install a 0 Ω 603 resistor or connect the two pads with solder. The optional connections are non-populated (no-pop) resistor footprints. To connect, install a 0 Ω 603 resistor or connect the two pads with solder. The User Control ON connections are only enabled when the User Control switch is moved to the ON position.

Table 6 shows a summary of the default and optional connections for each pin.

**Table 6. MCU Pin Functions**

MCU Pin	MCU Card Function			UDP Motherboard Signal	
	Default	Optional	User Control ON	Default	Optional
P0.0				USART_TX_A	
P0.1	CAPSENSE			USART_RX_A	
P0.2	CAPSENSE			USART_RTS_A C2D_TX00_A	
P0.3	CAPSENSE			USART_CTS_A C2D_TX01_A	
P0.4	CAPSENSE			USART_UCLK_A C2D_TX02_A	
P0.5				SPI_SCK_EZR C2D_TX03_A	
P0.6				SPI_MISO_EZR C2D_TX04_A	
P0.7				SPI_MOSI_EZR C2D_TX05_A I2V_INP_A	
P0.8				SPI_NSS0_EZR C2D_TX06_A I2V_INN_A	
P0.9	RTC1				GPIO14
P0.10	RTC2				GPIO15
P0.11		VREFGND		GPIO11 ADC_VREFGND	
P0.12		VREF		GPIO12 ADC_VREF	
P0.13		IDAC		PCA_CH0_A GPIO13 IDAC_B	
P0.14				PCA_CH1_A I2SOUT_DFS_A IDAC_A	
P0.15	XTAL1				I2SOUT_CLK_A CP_OUT_A

Table 6. MCU Pin Functions (Continued)

MCU Pin	MCU Card Function			UDP Motherboard Signal	
	Default	Optional	User Control ON	Default	Optional
P1.0	XTAL2				I2SOUT_DOUT_A CP_OUTA_A
P1.1				I2C_SDA_EZR	
P1.2				I2C_SCL_EZR	
P1.3				JTAG_TDO_A	
P1.4				JTAG_TDI_A	
P1.5			POT		ADC_IN0
P1.6					ADC_IN1
P1.7	CAPSENSE				GPIO08
P1.8	CAPSENSE				GPIO09
P1.9					GPIO10
P1.10				ADC_IN2	
P1.11				TIMER_EX_A ADC_IN3	
P1.12		VCP_RX		EMIF_A21	UART_RX_SYS
P1.13		VCP_TX		EMIF_A20	UART_TX_SYS
P1.14		VCP_CTS		EMIF_A19 EZRP_CLK_IN	UART_CTS_SYS
P1.15		VCP_RTS		WAKEUP0 EMIF_A18 EZRP_TX_DATA_IN	UART_RTS_SYS
P2.0				EMIC_A17 EZRP_RX_CLK_OUT	
P2.1				USART_TX_B EMIF_A16 EZRP_RX_DATA_OUT	
P2.2				USART_RX_B EMIF_A15 EZRP_SDN	
P2.3				EMIF_A14 EZRP_NIRQ	
P2.4				EXT_INT0 EMIF_A13	
P2.5				GPIO00 EMIF_A12	
P2.6				GPIO01 EMIF_A11	
P2.7				GPIO02 EMIF_A10	

**Table 6. MCU Pin Functions (Continued)**

MCU Pin	MCU Card Function			UDP Motherboard Signal	
	Default	Optional	User Control ON	Default	Optional
P2.8			SW2	SPI_NSS3_A GPIO03 EMIF_A9	
P2.9			SW3	SPI_NSS2_A GPIO04 EMIF_A8	
P2.10			LED (DS3)	SPI_NSS1_A GPIO05 EMIF_A7	
P2.11			LED (DS4)	SPI_NSS0_A GPIO06 EMIF_A6	
P2.12			POT_EN	SPI_SCK_A GPIO07 EMIF_A5	
P2.13				SPI_MISO_A EMIF_A4 CP_POS_A	
P2.14				SPI_MOSI_A EMIF_A3 CP_NEG_A	
P3.0				EMIF_A2	
P3.1				SPI_NSS2_EZR EMIF_A1	
P3.2				SPI_NSS3_EZR EMIF_A0	
P3.3				LPTIMER_IN_A I2SIN_DFS_A EMIF_WRB	
P3.4				I2SIN_CLK_A EMIF_OEB CP_POS_B	
P3.5				I2SIN_DOUT_A EMIF_ALE CP_NEG_B	
P3.6				EMIF_CS0B EXTREG_SP_A	
P3.7				EMIF_BE1B EXTREG_SN_A	
P3.8				EMIF_CS1B EXTREG_OUT_A	



**Table 6. MCU Pin Functions (Continued)**

MCU Pin	MCU Card Function			UDP Motherboard Signal	
	Default	Optional	User Control ON	Default	Optional
P3.9				EMIF_BE0B EXTREG_BD_A	
P3.10	EBID_SCK			PORT_MATCH0 UDPBUS_SDA_A	
P3.11	EBID_SDA			PORT_MATCH1 UDPBUS_SCL_A	
P4.0				EPCA_CH0_MOTOR HVGPI00	
P4.1				EPCA_CH1_MOTOR HVGPI01	
P4.2				UART_TX_A EPCA_CH2_MOTOR HVGPI02	
P4.3				UART_RX_A EPCA_CH3_MOTOR HVGPI03	
P4.4				UART_RTS_A EPCA_CH4_MOTOR HVGPI04	
P4.5				LPTIMER_OUT_A UART_CTS_A EPCA_CH5_MOTOR HVGPI05	

#### 4.15.1. P0.1, P0.2, P0.3, P0.4, P1.8, P1.7

Pins P0.1, P0.2, P0.3, P0.4, P1.7, P1.8 all connect to the capacitive sensing slider by default. To disconnect any of these pins from the capacitive sensing slider, remove the 0 Ω resistor that is connected to the port pin (R16 - R21).

#### 4.15.2. P0.9, P0.10

Pins P0.9 and P0.10 both connect to the 32.768 kHz RTC by default. To disconnect this pin from the RTC, remove the crystal Y2 on the board. Alternatively, the 0 Ω resistors R5 and R6 can be removed to disconnect the RTC circuit from the headers on J5.

#### 4.15.3. P0.11

Pin P0.11 connects to the VREFGND terminal on H1 by default. By default, P0.11 is not used as VREFGND and is instead a GPIO pin.

#### 4.15.4. P0.12

Pin P0.12 connects to the RX pin of the CP210x by default. Alternatively, P0.12 can be enabled for use with the VREF.

#### 4.15.5. P0.13

Pin P0.13 connects to the TX pin of the CP210x by default. Alternatively, P0.13 can be enabled for use with the IDAC.

#### **4.15.6. P0.14**

Pin P0.14 connects to the CTS pin of the CP210x by default.

#### **4.15.7. P0.15**

Pin P0.15 connects to the RTS pin of the CP210x by default. Alternatively, P0.15 can be enabled for use as the XTAL1 input.

#### **4.15.8. P1.0**

Pin P1.0 is a GPIO pin by default. Alternatively, P1.0 can be enabled for use as the XTAL2 input. P1.0 is connected to the external crystal circuit, but the external crystal circuit is not populated by default. See the MCU card schematic in 6. "Schematics," on page 18 for more information on the external crystal circuit.

#### **4.15.9. P1.5**

Pin P1.5 is a GPIO pin by default. Alternatively, P1.5 can be used at the potentiometer input pin if the User Control switch is in the ON position.

#### **4.15.10. P2.8, P2.9**

Pins P2.8 and P2.9 are both GPIO pins by default. Alternatively, P2.8 and P2.9 can be used as switches (SW2 and SW3) if the User Control switch is in the ON position.

#### **4.15.11. P2.10, P2.11**

Pins P2.10 and P2.11 are both GPIO pins by default. Alternatively, P2.10 and P2.11 can be used as LEDs (DS3 and DS4) if the User Control switch is in the ON position.

#### **4.15.12. P2.12**

Pin P2.12 is a GPIO pin by default. Alternatively, P2.12 can be used at the potentiometer bias pin if the User Control switch is in the ON position.

#### **4.15.13. P3.10, P3.11**

Pins P3.10 and P3.11 normally connects to the EBID UDP bus. To disconnect these pins from the UDP bus circuit, remove the 0  $\Omega$  resistors R34 and R35.

## 5. Using the UDP SiM3U1xx MCU Card with the UDP Motherboard

### 5.1. Current Measurement

The power measurement circuitry on the UDP motherboard consists of a Silicon Labs C8051F351 8051 MCU that measures both input voltage and current consumption of the MCU card, I/O expander, and radio test card. Install a shorting block on the UDP Motherboard J13 and J15 connecting the two left pins together when using the motherboard with the SiM3U1xx MCU card.

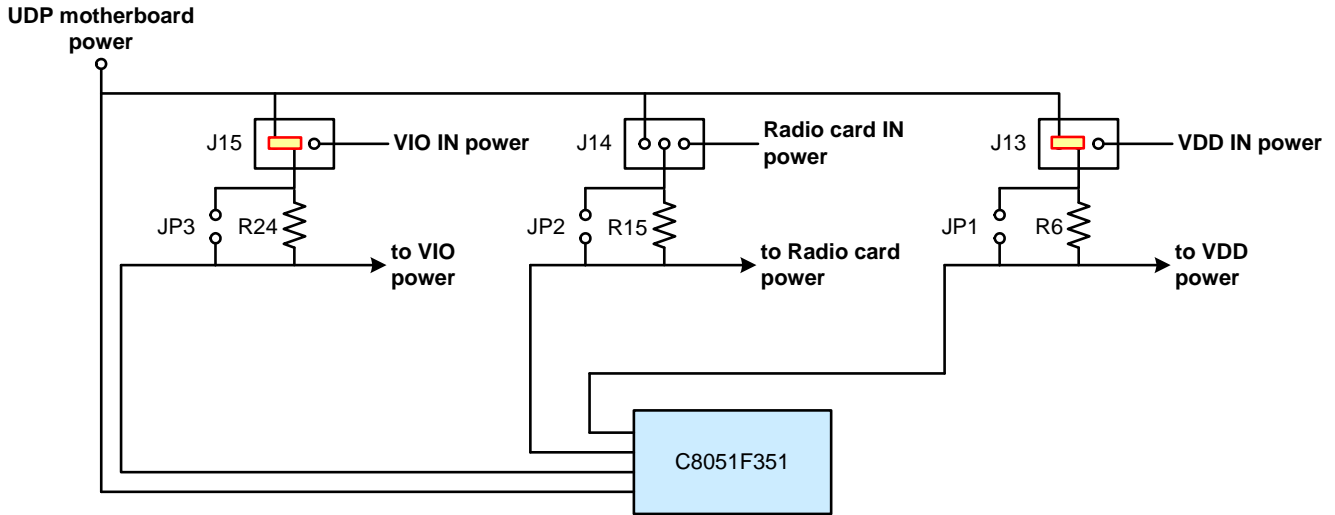

Figure 7. Power Measurement Diagram with Shorting Blocks

### 5.2. MCU Card Header Connections

The MCU card has four connectors with 100 pins each. These 400 pins are directly tied to the UDP motherboard and I/O cards. These signals are named and designed to support a wide variety of features and applications, and the UDP SiM3U1xx card implements a subset of these connections.

The MCU cards and I/O cards are designed so that a maximum number of functions are shared between each card. This allows a particular type of I/O card to be shared among all MCU cards that connect to the same signals.

The MCU card slot includes the following components:

J1	MCU card connector H1
J2	MCU card connector H2
J3	MCU card connector H3
J4	MCU card connector H4

The UDP SiM3U1xx card implements the signals described in Table 8, Table 9, Table 10, and Table 11 in the Appendix.

5.3. Shorting Blocks: Factory Defaults

The UDP SiM3U1xx MCU card comes from the factory with pre-installed shorting blocks on several headers. Figure 8 shows the positions of the factory default shorting blocks.

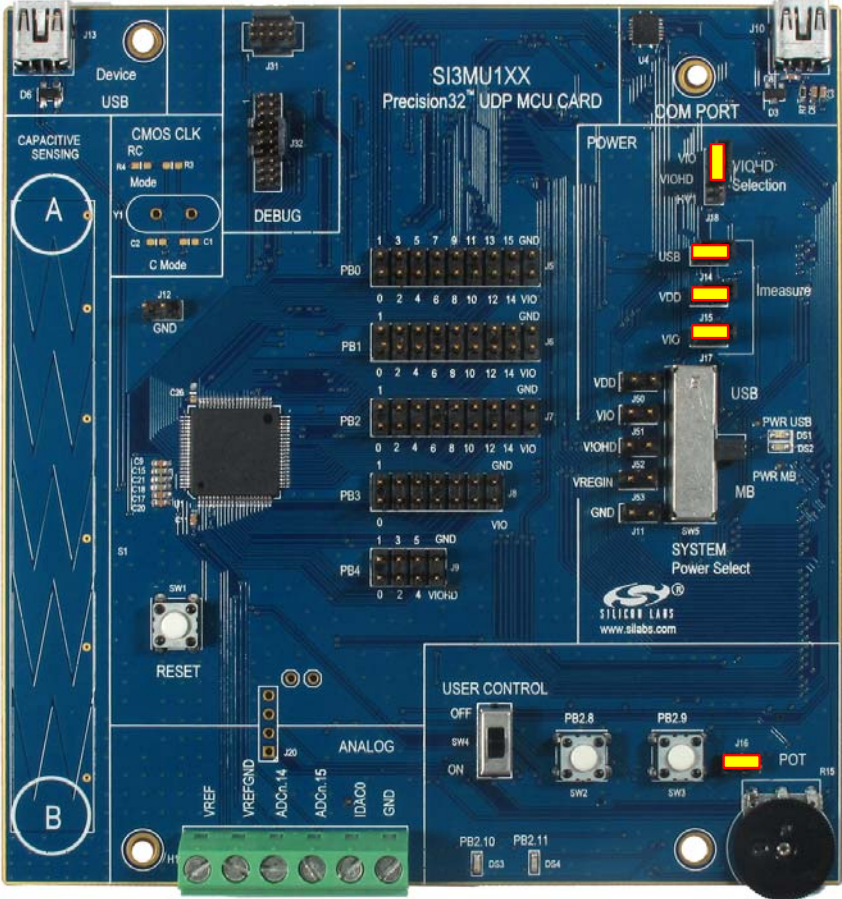

Figure 8. Shorting Blocks: Factory Defaults

Shorting blocks are installed across the USB (J14), VDD (J15), VIO (J17) Imeasure jumpers. A shorting block is installed on J16 to connect the potentiometer to the User Control portion of the board. A shorting block is also installed on J18 to connect the VIOHD pin of the MCU to the VIO pin of the MCU.

## 6. Schematics

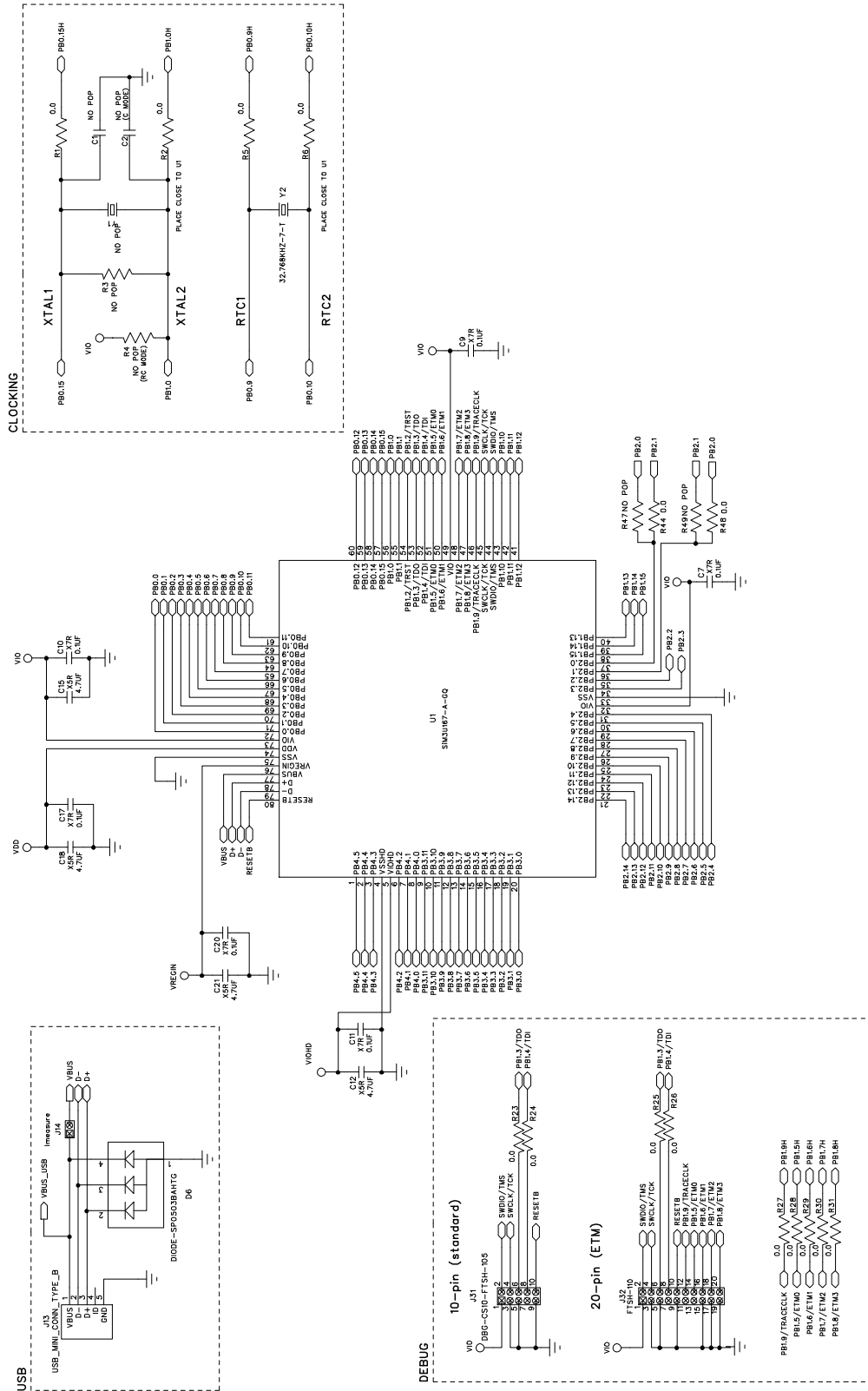

Figure 9. SiM3U1xx UDP MCU Card Schematic (1 of 6)



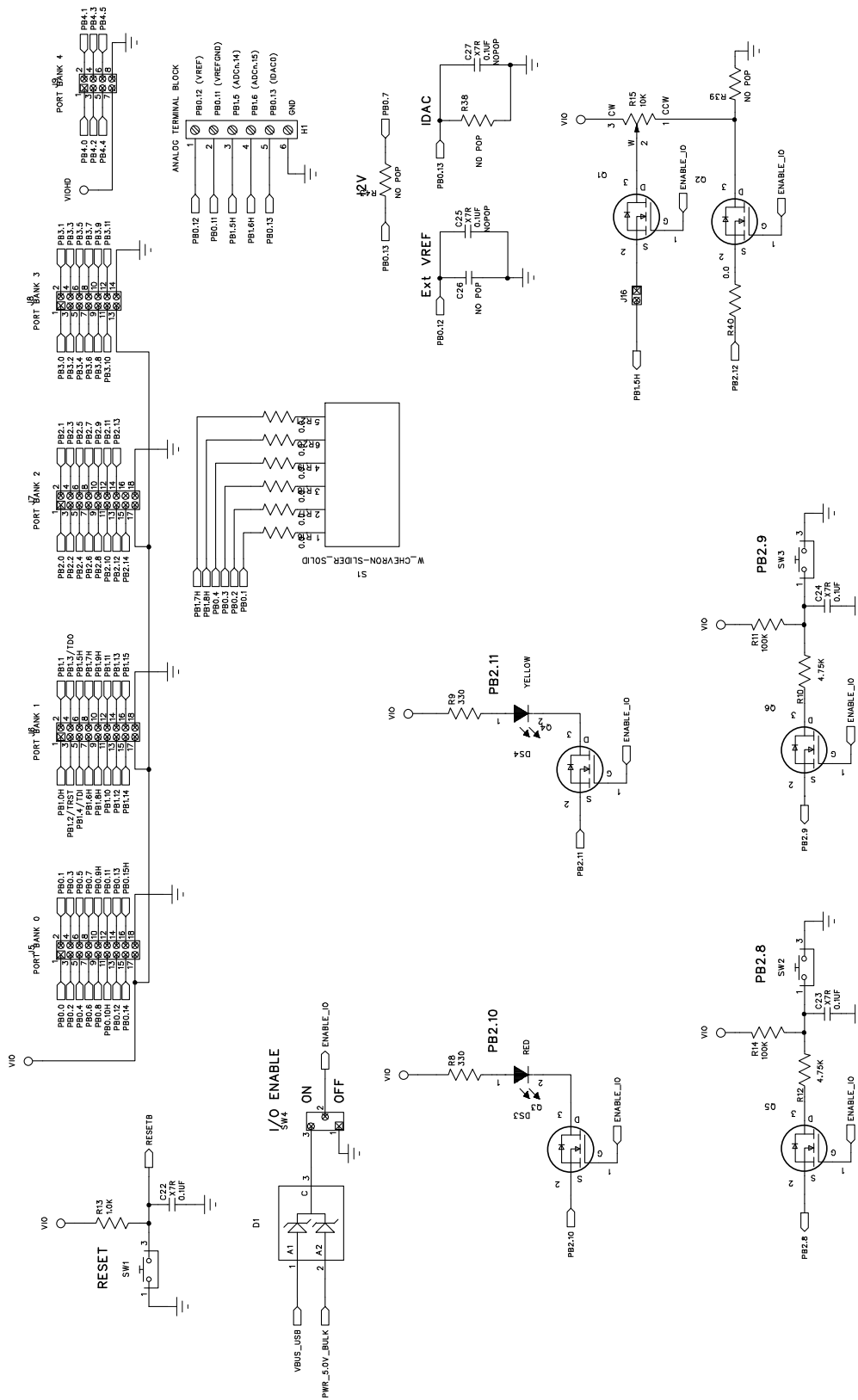

Figure 10. SIM3U1xx UDP MCU Card Schematic (2 of 6)

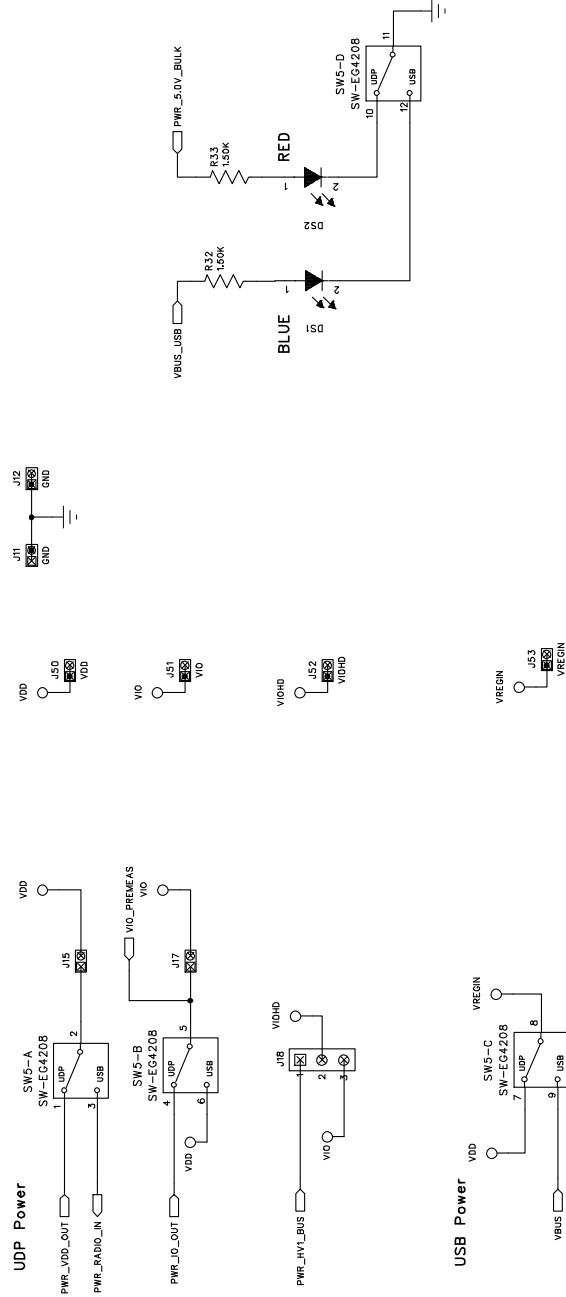

Figure 11. SiM3U1xx UDP MCU Card Schematic (3 of 6)

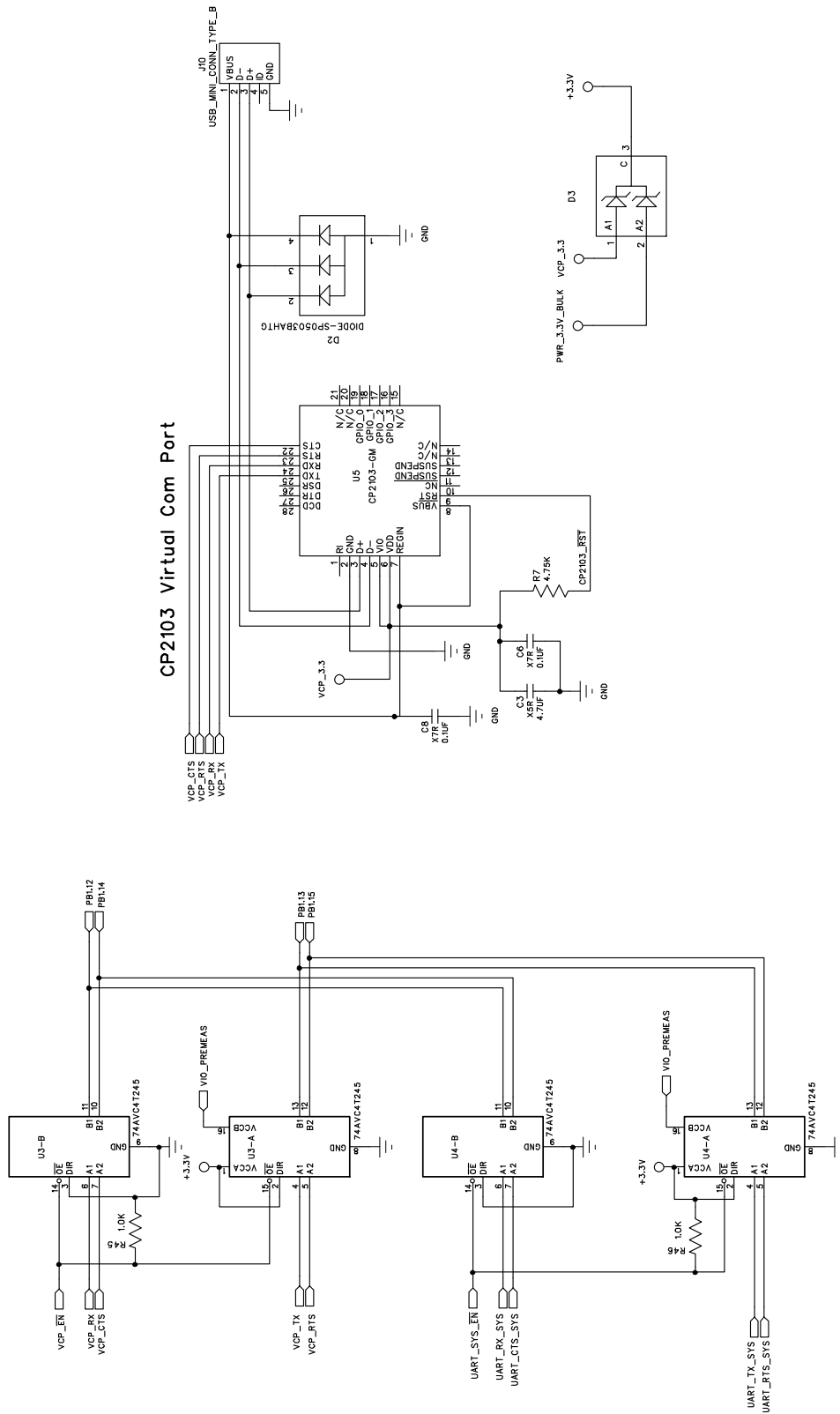
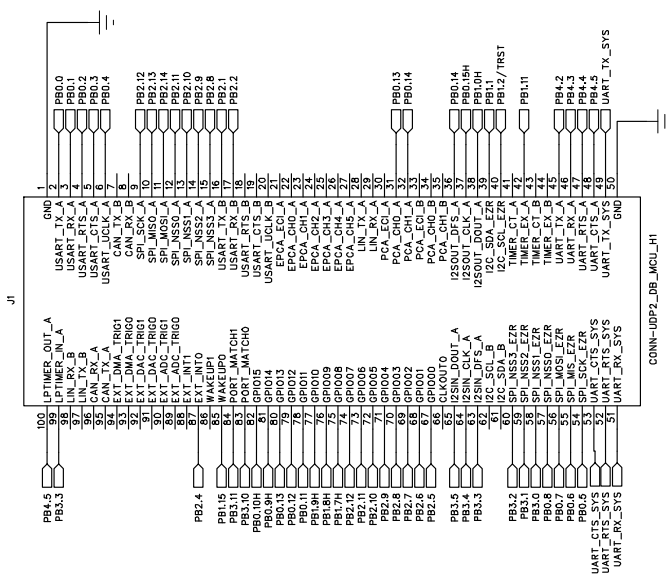
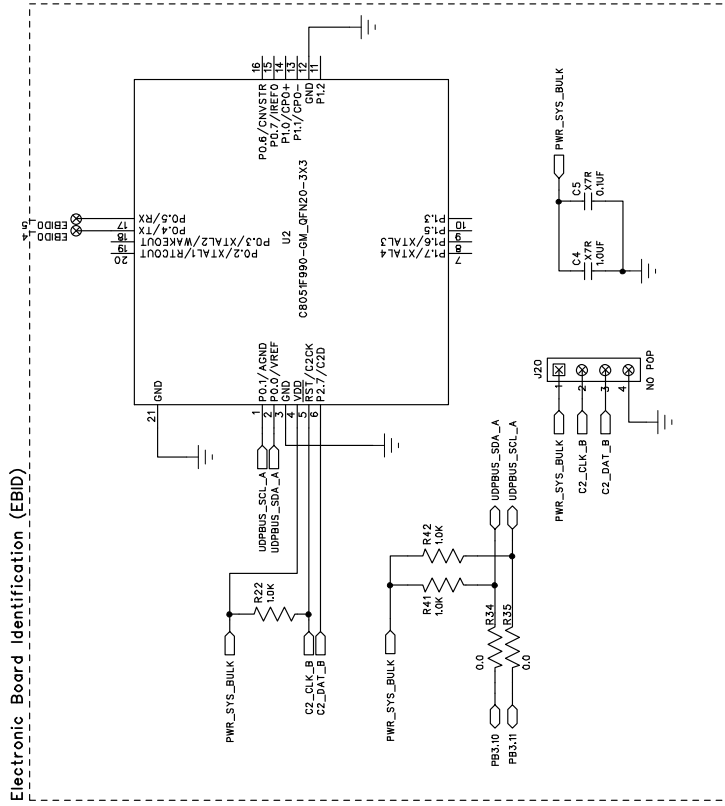

Figure 12. SiM3U1xx UDP MCU Card Schematic (4 of 6)



UDP Header 1 (Top View)

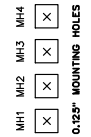
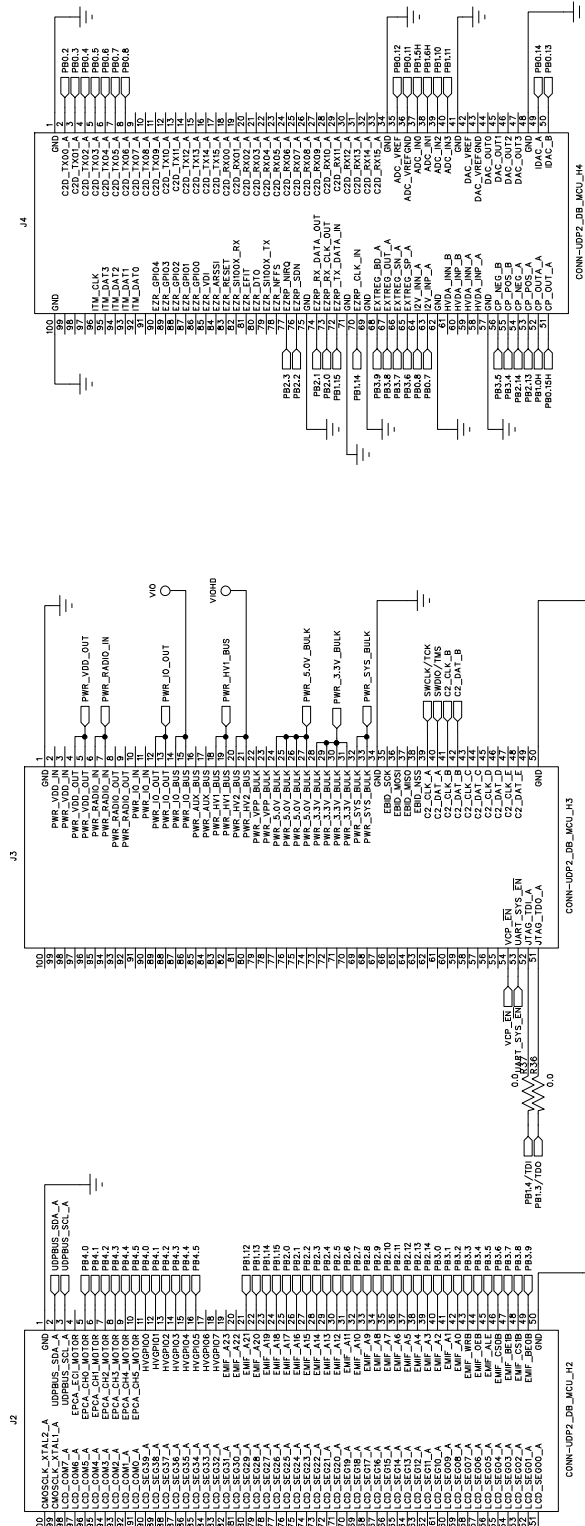

Figure 13. SIM3U1xx UDP MCU Card Schematic (5 of 6)



UDP Header 2 (Top View)

UDP Header 3 (Top View)

UDP Header 4 (Top View)

Figure 14. SiM3U1xx UDP MCU Card Schematic (6 of 6)



# UDP SiM3U1xx

## 7. Bill of Materials

**Table 7. UDP SiM3U1xx Card Bill of Materials**

Reference	Part Number	Source	Description
U3-4	SN74AVC4T245RGR	Texas Instruments	IC, BUS TRANSCVR, 4BIT, 16QFN, RoHS
U2	C8051F990-GM	Silicon Labs	MIXED SIGNAL, MCU, QFN20-3X3, RoHS
U1	SiM3U167-A-GQ	Silicon Labs	MCU, TQFP80-14X14, RoHS
C5-11, C17, C20, C22-25, C27	C0603C104J3RACTU	Kemet	CAP, 0.1 $\mu$ F, X7R, CERAMIC, 0603, 25 V, $\pm$ 5%, OR EQ, RoHS
C4	C1608X7R1C105K	TDK Corporation	CAP CERAMIC, 1.0UF, X7R, 0603, 16 V, $\pm$ 10%, OR EQ, RoHS
C3, C12, C15, C18, C21	ECJ-1VB0J475M	Panasonic - ECG	CAP, 4.7UF, X5R, CERAMIC, 0603, 6.3 V, $\pm$ 20%, OR EQ, RoHS
C1-2, C26			CAP, NO POP, 0603, OR EQ, RoHS
J1-4	FX8-100P-SV1(91)	Hirose Electric Co Ltd	CONN, HDR, 100POS, .6 mm, GOLD, SMD, RoHS
U5	CP2103	Silicon Labs	SINGLE-CHIP USB TO UART BRIDGE, QFN28, RoHS
J31	FTSH-105-01-F-D-K	Samtec Inc	CoreSight 10 Debug Header
J32	FTSH-110-L-D-K	Samtec Inc	CONN, HDR, SHRD, 0.050"(1.27 mm) PITCH, 20 PINS [2X10], OR EQ, RoHS
D1, D3	BAT54C-G	Comchip Technology	DIODE, Schottkey DUAL CC, 200 mA, 30 V, SOT23, RoHS
D2, D6	SP0503BAHTG	Littlefuse	TVS AVAL DIODE ARRAY, 3 CH, SOT143, RoHS
Q1-6	DMN2075U-7	Diodes Inc	MOSFET, PWR N-CHAN, 20 V, 4.2A, SOT- 23, OR EQ, RoHS
J15, J11-12, J17, J50-53	PBC02SAAN	Sullins Connector Solutions	STAKE HEADER, 1X2, 0.1"CTR, GOLD, OR EQ, RoHS
J14, J16	PBC02DAAN	Sullins Connector Solutions	STAKE HEADER, 1X2, 0.1"CTR, GOLD, OR EQ, RoHS
J18	PBC03SAAN	Sullins Connector Solutions	STAKE HEADER, 1X3, 0.1" CTRS, OR EQ, RoHS
J20	PBC04SAAN	Sullins Connector Solutions	STAKE HEADER, 1X4, 0.1" CTRS, OR EQ, RoHS, NO POP
J9	PBC04DAAN	Sullins Connector Solutions	STAKE HEADER, 2X4, 0.1"CTR, OR EQ, RoHS
J8	PBC07DAAN	Sullins Connector Solutions	STAKE HEADER, 2X7, 0.1" CTR, GOLD, OR EQ, RoHS
J5-7	PBC09DAAN	Sullins Connector Solutions	STAKE HEADER, 2X9, 0.1" CTR, GOLD, OR EQ, RoHS
DS1	LTST-C190TBKT	Lite-On Inc	LED 468NM, BLUE, SMT0603, OR EQ, RoHS
DS2-3	SML-LX0603IW-TR	Lumex Opto / Components Inc	LED, RED DIFF, 635NM, SMT0603, OR EQ, RoHS

**Table 7. UDP SiM3U1xx Card Bill of Materials**

Reference	Part Number	Source	Description
DS4	LY L29K-H1K2-26-Z	OSRAM Opto Semiconductors Inc	LED, YELLOW, 591NM, SMD0603, 1.8 V, OR EQ, RoHS
R15	RV100F-30-4K1B-B10K-B301	Alpha (Taiwan)	POT, 10 k, THUMBWHEEL LINEAR, 0.03W, ±20%, OR EQ, RoHS
R1-2, R5-6, R16-21, R23-31, R34-37, R40, R44, R48	RC0603JR-070RL	Yageo	RES, 0.0, SMT, 0603, 1/10W, ±5%, OR EQ, RoHS
R32-33	ERJ-3EKF1501V	Panasonic - ECG	RES 1.50 kΩ, SMT, 0603, 1/10W, ±1%, OR EQ, RoHS
R11, R14	ERJ-6ENF1003V	Panasonic - ECG	RES, 100 k, SMT, 0805, 1/8W, ±1%, OR EQ, RoHS
R13, R22, R41-42, R45-46	RC0603JR-071KL	Yageo	RES, 1.0 kΩ, SMT, 0603, 1/10W, ±5%, RoHS
R8-9	RC0805JR-07330RL	Yageo	RES, 330 Ω, SMT, 0805, 1/8W, ±5%, OR EQ, RoHS
R7	ERJ-3EKF4751V	Panasonic - ECG	RES, 4.75 kΩ, SMT, 0603, 1/10W, ±1%, OR EQ, RoHS
R10, R12	ERJ-6ENF4751V	Panasonic - ECG	RES, 4.75 kΩ, SMT, 0805, 1/8W, ±1%, OR EQ, RoHS
R3-4, R38-39, R43, R47, R49			RES, NO POP, SMT, 0603, OR EQ, RoHS
SW4	OS102011MS2QN1	C&K Components	SWITCH SLIDE MINI, SPDT, PCB MNT, OR EQ, RoHS
SW5	EG6201	E-Switch	SWITCH, SLIDE 6PDT, RT ANG, L=4 mm, OR EQ, RoHS
SW1-3	EVQ-PAD04M	Panasonic - ECG	SWITCH, LIGHT TOUCH, 130GF, 6MM SQ, RoHS
H1	1729160	Phoenix Contact	TERM. BLOCK, 5.08 mm CTRS, 6 POS, RoHS
J10, J13	54819-0519	Molex Inc	CONN, USB MINI RECEPT, 5POS RT ANG, TYPE B OR EQ, RoHS
S1			PCB W_CHEVRON SLIDER SOLID, RoHS
Y2	ABS07-32.768KHZ-7-T	Abracon Corporation	CRYSTAL, 32.76 kHz, 7PF, SMT, RoHS
Y1		ECS Inc	HC46/9 CRYSTAL, NO POP, OR EQ, RoHS

# UDP SiM3U1xx

## APPENDIX—MCU CARD HEADER PIN DESCRIPTIONS

Table 8. UDP SiM3U1xx MCU Card H1 Pin Descriptions (J1)

MCU Card Pin	Signal Name	Description	SiM3U167 Pin / Signal
1	GND		
2	USART_TX_A	USART A transmit	PB0.0
3	USART_RX_A	USART A receive	PB0.1
4	USART_RTS_A	USART A hardware handshaking	PB0.2
5	USART_CTS_A	USART A hardware handshaking	PB0.3
6	USART_UCLK_A	USART A clock	PB0.4
7	CAN_TX_B		
8	CAN_RX_B		
9	SPI_SCK_A	SPI A clock	PB2.12
10	SPI_MISO_A	SPI A master-in, slave-out	PB2.13
11	SPI_MOSI_A	SPI A master-out, slave-in	PB2.14
12	SPI_NSS0_A	SPI A slave select 0	PB2.11
13	SPI_NSS1_A	SPI A slave select 1	PB2.10
14	SPI_NSS2_A	SPI A slave select 2	PB2.9
15	SPI_NSS3_A	SPI A slave select 3	PB2.8
16	USART_TX_B	USART B transmit	PB2.1
17	USART_RX_B	USART B receive	PB2.2
18	USART_RTS_B	USART B hardware handshaking	
19	USART_CTS_B	USART B hardware handshaking	
20	USART_UCLK_B	USART B clock	
21	EPCA_ECI_A	EPCA A external clock input	
22	EPCA_CH0_A		
23	EPCA_CH1_A		
24	EPCA_CH2_A		
25	EPCA_CH3_A		
26	EPCA_CH4_A		
27	EPCA_CH5_A		
28	LIN_TX_A		
29	LIN_RX_A		
30	PCA_ECI_A	PCA A external clock input	
31	PCA_CH0_A		PB0.13
32	PCA_CH1_A		PB0.14
33	PCA_ECI_B	PCA B external clock input	
34	PCA_CH0_B		

**Table 8. UDP SiM3U1xx MCU Card H1 Pin Descriptions (J1) (Continued)**

MCU Card Pin	Signal Name	Description	SiM3U167 Pin / Signal
35	PCA_CH1_B		
36	I2SOUT_DFS_A	I2S A transmitter word sync (WS)	PB0.14
37	I2SOUT_CLK_A	I2S A transmitter clock (SCK)	PB0.15H
38	I2SOUT_DOUT_A	I2S A transmitter data (SD)	PB1.0H
39	I2C_SDA_EZR	EZRadio I2C data	PB1.1
40	I2C_SCL_EZR	EZRadio I2C clock	PB1.2 / TRST
41	TIMER_CT_A		
42	TIMER_EX_A		PB1.11
43	TIMER_CT_B		
44	TIMER_EX_B		
45	UART_TX_A	UART A transmit	PB4.2
46	UART_RX_A	UART A receive	PB4.3
47	UART_RTS_A	UART A hardware handshaking	PB4.4
48	UART_CTS_A	UART A hardware handshaking	PB4.5
49	UART_TX_SYS	System UART transmit	UART_TX_SYS
50	GND		
51	UART_RX_SYS	System UART receive	UART_RX_SYS
52	UART_RTS_SYS	System UART hardware handshaking	UART_RTS_SYS
53	UART_CTS_SYS	System UART hardware handshaking	UART_CTS_SYS
54	SPI_SCK_EZR	EZRadio SPI clock	PB0.5
55	SPI_MISO_EZR	EZRadio SPI master-in, slave-out	PB0.6
56	SPI_MOSI_EZR	EZRadio SPI master-out, slave-in	PB0.7
57	SPI_NSS0_EZR	EZRadio SPI slave select 0	PB0.8
58	SPI_NSS1_EZR	EZRadio SPI slave select 1	PB3.0
59	SPI_NSS2_EZR	EZRadio SPI slave select 2	PB3.1
60	SPI_NSS3_EZR	EZRadio SPI slave select 3	PB3.2
61	I2C_SDA_B	I <sup>2</sup> C B data	
62	I2C_SCL_B	I <sup>2</sup> C B clock	
63	I2SIN_DFS_A	I <sup>2</sup> S A receiver word sync (WS)	PB3.3
64	I2SIN_CLK_A	I <sup>2</sup> S A receiver clock (SCK)	PB3.4
65	I2SIN_DOUT_A	I <sup>2</sup> S A receiver data (SD)	PB3.5
66	CLKOUT0	clock	
67	GPIO00	General purpose I/O 0	PB2.5
68	GPIO01	General purpose I/O 1	PB2.6

# UDP SiM3U1xx

Table 8. UDP SiM3U1xx MCU Card H1 Pin Descriptions (J1) (Continued)

MCU Card Pin	Signal Name	Description	SiM3U167 Pin / Signal
69	GPIO02	General purpose I/O 2	PB2.7
70	GPIO03	General purpose I/O 3	PB2.8
71	GPIO04	General purpose I/O 4	PB2.9
72	GPIO05	General purpose I/O 5	PB2.10
73	GPIO06	General purpose I/O 6	PB2.11
74	GPIO07	General purpose I/O 7	PB2.12
75	GPIO08	General purpose I/O 8	PB1.7H
76	GPIO09	General purpose I/O 9	PB1.8H
77	GPIO10	General purpose I/O 10	PB1.9H
78	GPIO11	General purpose I/O 11	PB0.11
79	GPIO12	General purpose I/O 12	PB0.12
80	GPIO13	General purpose I/O 13	PB0.13
81	GPIO14	General purpose I/O 14	PB0.9H
82	GPIO15	General purpose I/O 15	PB0.10H
83	PORT_MATCH0	PB3.10	
84	PORT_MATCH1	PB3.11	
85	WAKEUP0	MCU low-power wakeup input signal 0	PB1.15
86	WAKEUP1	MCU low-power wakeup input signal 1	
87	EXT_INT0	External interrupt 0	PB2.4
88	EXT_INT1	External interrupt 1	
89	EXT_ADC_TRIG0	External ADC trigger 0	
90	EXT_ADC_TRIG1	External ADC trigger 1	
91	EXT_DAC_TRIG0	External DAC trigger 0	
92	EXT_DAC_TRIG1	External DAC trigger 1	
93	EXT_DMA_TRIG0	External DMA trigger 0	
94	EXT_DMA_TRIG1	External DMA trigger 1	
95	CAN_TX_A		
96	CAN_RX_A		
97	LIN_TX_B		
98	LIN_RX_B		
99	LPTIMER_IN_A		PB3.3
100	LPTIMER_OUT_A		PB4.5



**Table 9. UDP SiM3U1xx Card H2 Pin Descriptions (J2)**

MCU Card Pin	Signal Name	Description	SiM3U167 Pin / Signal
1	GND		
2	UDPBUS_SDA_A	UDP motherboard I2C A data	UDPBUS_SDA_A
3	UDPBUS_SCL_A	UDP motherboard I2C A clock	UDPBUS_SCL_A
4	EPCA_ECI_MOTOR	Motor EPCA external clock input	
5	EPCA_CH0_MOTOR		PB4.0
6	EPCA_CH1_MOTOR		PB4.1
7	EPCA_CH2_MOTOR		PB4.2
8	EPCA_CH3_MOTOR		PB4.3
9	EPCA_CH4_MOTOR		PB4.4
10	EPCA_CH5_MOTOR		PB4.5
11	HVGPIO0	High Drive I/O 0	PB4.0
12	HVGPIO1	High Drive I/O 1	PB4.1
13	HVGPIO2	High Drive I/O 2	PB4.2
14	HVGPIO3	High Drive I/O 3	PB4.3
15	HVGPIO4	High Drive I/O 4	PB4.4
16	HVGPIO5	High Drive I/O 5	PB4.5
17	HVGPIO6	High Drive I/O 6	
18	HVGPIO7	High Drive I/O 7	
19	EMIF_A23	EMIF muxed AD23m pin (non-muxed A15)	
20	EMIF_A22	EMIF muxed AD22m pin (non-muxed A14)	
21	EMIF_A21	EMIF muxed AD21m pin (non-muxed A13)	PB1.12
22	EMIF_A20	EMIF muxed AD20m pin (non-muxed A12)	PB1.13
23	EMIF_A19	EMIF muxed AD19m pin (non-muxed A11)	PB1.14
24	EMIF_A18	EMIF muxed AD18m pin (non-muxed A10)	PB1.15
25	EMIF_A17	EMIF muxed AD17m pin (non-muxed A9)	PB2.0
26	EMIF_A16	EMIF muxed AD16m pin (non-muxed A8)	PB2.1
27	EMIF_A15	EMIF muxed AD15m pin (non-muxed A7)	PB2.2
28	EMIF_A14	EMIF muxed AD14m pin (non-muxed A6)	PB2.3
29	EMIF_A13	EMIF muxed AD13m pin (non-muxed A5)	PB2.4
30	EMIF_A12	EMIF muxed AD12m pin (non-muxed A4)	PB2.5
31	EMIF_A11	EMIF muxed AD11m pin (non-muxed A3)	PB2.6
32	EMIF_A10	EMIF muxed AD10m pin (non-muxed A2)	PB2.7
33	EMIF_A9	EMIF muxed AD9m pin (non-muxed A1)	PB2.8
34	EMIF_A8	EMIF muxed AD8m pin (non-muxed A0)	PB2.9
35	EMIF_A7	EMIF muxed AD7m pin (non-muxed D7)	PB2.10

# UDP SiM3U1xx

Table 9. UDP SiM3U1xx Card H2 Pin Descriptions (J2) (Continued)

MCU Card Pin	Signal Name	Description	SiM3U167 Pin / Signal
36	EMIF_A6	EMIF muxed AD6m pin (non-muxed D6)	PB2.11
37	EMIF_A5	EMIF muxed AD5m pin (non-muxed D5)	PB2.12
38	EMIF_A4	EMIF muxed AD4m pin (non-muxed D4)	PB2.13
39	EMIF_A3	EMIF muxed AD3m pin (non-muxed D3)	PB2.14
40	EMIF_A2	EMIF muxed AD2m pin (non-muxed D2)	PB3.0
41	EMIF_A1	EMIF muxed AD1m pin (non-muxed D1)	PB3.1
42	EMIF_A0	EMIF muxed AD0m pin (non-muxed D0)	PB3.2
43	EMIF_WRB	EMIF write signal	PB3.3
44	EMIF_OEB	EMIF output enable	PB3.4
45	EMIF_ALE	EMIF address latch enable	PB3.5
46	EMIF_CS0B	EMIF chip select 0	PB3.6
47	EMIF_BE1B	EMIF output byte enable 1	PB3.7
48	EMIF_CS1B	EMIF chip select 1	PB3.8
49	EMIF_BE0B	EMIF output byte enable 0	PB3.9
50	GND		
51	LCD_SEG00_A		
52	LCD_SEG01_A		
53	LCD_SEG02_A		
54	LCD_SEG03_A		
55	LCD_SEG04_A		
56	LCD_SEG05_A		
57	LCD_SEG06_A		
58	LCD_SEG07_A		
59	LCD_SEG08_A		
60	LCD_SEG09_A		
61	LCD_SEG10_A		
62	LCD_SEG11_A		
63	LCD_SEG12_A		
64	LCD_SEG13_A		
65	LCD_SEG14_A		
66	LCD_SEG15_A		
67	LCD_SEG16_A		
68	LCD_SEG17_A		
69	LCD_SEG18_A		
70	LCD_SEG19_A		
71	LCD_SEG20_A		
72	LCD_SEG21_A		

**Table 9. UDP SiM3U1xx Card H2 Pin Descriptions (J2) (Continued)**

MCU Card Pin	Signal Name	Description	SiM3U167 Pin / Signal
73	LCD_SEG22_A		
74	LCD_SEG23_A		
75	LCD_SEG24_A		
76	LCD_SEG25_A		
77	LCD_SEG26_A		
78	LCD_SEG27_A		
79	LCD_SEG28_A		
80	LCD_SEG29_A		
81	LCD_SEG30_A		
82	LCD_SEG31_A		
83	LCD_SEG32_A		
84	LCD_SEG33_A		
85	LCD_SEG34_A		
86	LCD_SEG35_A		
87	LCD_SEG36_A		
88	LCD_SEG37_A		
89	LCD_SEG38_A		
90	LCD_SEG39_A		
91	LCD_COM0_A		
92	LCD_COM1_A		
93	LCD_COM2_A		
94	LCD_COM3_A		
95	LCD_COM4_A		
96	LCD_COM5_A		
97	LCD_COM6_A		
98	LCD_COM7_A		
99	CMOSCLK_XTAL1_A	MCU XTAL1 pin for external oscillators	
100	CMOSCLK_XTAL2_A	MCU XTAL2 pin for external oscillators	

# UDP SiM3U1xx

**Table 10. UDP SiM3U1xx Card H3 Pin Descriptions (J3)**

MCU Card Pin	Description	Description	SiM3U167 Pin / Signal
1	GND		
2	PWR_VDD_IN	Power input for powering the MCU card from a power source other than the UDP motherboard	
3	PWR_VDD_IN	Power input for powering the MCU card from a power source other than the UDP motherboard	
4	PWR_VDD_OUT	Power input for the MCU card	PWR_VDD_OUT
5	PWR_VDD_OUT		
6	PWR_RADIO_IN	Power input for powering the radio test card from a power source other than the UDP motherboard	PWR_RADIO_IN
7	PWR_RADIO_IN		
8	PWR_RADIO_OUT	Power input for the radio test card	
9	PWR_RADIO_OUT	Power input for the radio test card	
10	PWR_IO_IN	Power input for powering the I/O card from a power source other than the UDP motherboard	
11	PWR_IO_IN	Power input for powering the I/O card from a power source other than the UDP motherboard	
12	PWR_IO_OUT	Power input for the I/O card	PWR_IO_OUT
13	PWR_IO_OUT		
14	PWR_IO_BUS	Connects power from the MCU card to the radio and I/O cards	VIO
15	PWR_IO_BUS		
16	PWR_AUX_BUS	Connects power from the MCU card to the radio and I/O cards	
17	PWR_AUX_BUS	Connects power from the MCU card to the radio and I/O cards	
18	PWR_HV1_BUS	High Drive I/O power 1	PWR_HV1_BUS
19	PWR_HV1_BUS		
20	PWR_HV2_BUS	High Drive I/O power 2	VIOHD
21	PWR_HV2_BUS		
22	PWR_VPP_BULK	VPP programming voltage	
23	PWR_VPP_BULK	VPP programming voltage	
24	PWR_5.0_BULK	5.0 V power from the UDP motherboard	PWR_5.0V_BULK
25	PWR_5.0_BULK		
26	PWR_5.0_BULK		
27	PWR_5.0_BULK		
28	VCC_3.3V	3.3 V power from the UDP motherboard	PWR_3.3V_BULK
29	VCC_3.3V		
30	VCC_3.3V		
31	VCC_3.3V		

**Table 10. UDP SiM3U1xx Card H3 Pin Descriptions (J3) (Continued)**

MCU Card Pin	Description	Description	SiM3U167 Pin / Signal
32	PWR_SYS_BULK	3.3 V power supply for EBID devices	PWR_SYS_BULK
33	PWR_SYS_BULK		
34	GND		
35	EBID_SCK	EBID SPI clock	
36	EBID_MOSI	EBID SPI master-out, slave in	
37	EBID_MISO	EBID SPI master-in, slave-out	
38	EBID_NSS	EBID SPI slave select	
39	C2_CLK_A	C2 interface A clock, JTAG interface A TCK, Serial Wire SWCLK	SWCLK / TCK
40	C2_DAT_A	C2 interface A data, JTAG interface A TMS, Serial Wire SWDIO	SWDIO / TMS
41	C2_CLK_B	C2 interface B clock	C2_CLK_B
42	C2_DAT_B	C2 interface B data	C2_DAT_B
43	C2_CLK_C	C2 interface C clock	
44	C2_DAT_C	C2 interface C data	
45	C2_CLK_D	C2 interface D clock	
46	C2_DAT_D	C2 interface D data	
47	C2_CLK_E	C2 interface E clock	
48	C2_DAT_E	C2 interface E data	
49	nc	no connect	
50	GND		
51	JTAG_TDO_A	JTAG interface A data out (TDO), Serial Wire SWO	PB1.3 / TDO
52	JTAG_TDI_A	JTAG interface A data in (TDI)	PB1.4 / TDI
53	VCP_EN	Selects the USB-to-USART motherboard path	UART_SYS_EN
54	UART_SYS_EN	Selects the USB-to-USART motherboard path	VCP_EN
55	H3_55	General purpose signal	
56	H3_56	General purpose signal	
57	H3_57	General purpose signal	
58	H3_58	General purpose signal	
59	H3_59	General purpose signal	
60	H3_60	General purpose signal	
61	H3_61	General purpose signal	
62	H3_62	General purpose signal	
63	H3_63	General purpose signal	
64	H3_64	General purpose signal	
65	H3_65	General purpose signal	
66	H3_66	General purpose signal	

# UDP SiM3U1xx

Table 10. UDP SiM3U1xx Card H3 Pin Descriptions (J3) (Continued)

MCU Card Pin	Description	Description	SiM3U167 Pin / Signal
67	H3_67	General purpose signal	
68	H3_68	General purpose signal	
69	H3_69	General purpose signal	
70	H3_70	General purpose signal	
71	H3_71	General purpose signal	
72	H3_72	General purpose signal	
73	H3_73	General purpose signal	
74	H3_74	General purpose signal	
75	H3_75	General purpose signal	
76	H3_76	General purpose signal	
77	H3_77	General purpose signal	
78	H3_78	General purpose signal	
79	H3_79	General purpose signal	
80	H3_80	General purpose signal	
81	H3_81	General purpose signal	
82	H3_82	General purpose signal	
83	H3_83	General purpose signal	
84	H3_84	General purpose signal	
85	H3_85	General purpose signal	
86	H3_86	General purpose signal	
87	H3_87	General purpose signal	
88	H3_88	General purpose signal	
89	H3_89	General purpose signal	
90	H3_90	General purpose signal	
91	H3_91	General purpose signal	
92	H3_92	General purpose signal	
93	H3_93	General purpose signal	
94	H3_94	General purpose signal	
95	H3_95	General purpose signal	
96	H3_96	General purpose signal	
97	H3_97	General purpose signal	
98	H3_98	General purpose signal	
99	H3_99	General purpose signal	
100	H3_100	General purpose signal	



**Table 11. UDP SiM3U1xx Card H4 Pin Descriptions (J4)**

MCU Card Pin	Description	Description	SiM3U167 Pin / Signal
1	GND		
2	C2D_TX00_A	Capacitive Sensing output 0	PB0.2
3	C2D_TX01_A	Capacitive Sensing output 1	PB0.3
4	C2D_TX02_A	Capacitive Sensing output 2	PB0.4
5	C2D_TX03_A	Capacitive Sensing output 3	PB0.5
6	C2D_TX04_A	Capacitive Sensing output 4	PB0.6
7	C2D_TX05_A	Capacitive Sensing output 5	PB0.7
8	C2D_TX06_A	Capacitive Sensing output 6	PB0.8
9	C2D_TX07_A	Capacitive Sensing output 7	
10	C2D_TX08_A	Capacitive Sensing output 8	
11	C2D_TX09_A	Capacitive Sensing output 9	
12	C2D_TX10_A	Capacitive Sensing output 10	
13	C2D_TX11_A	Capacitive Sensing output 11	
14	C2D_TX12_A	Capacitive Sensing output 12	
15	C2D_TX13_A	Capacitive Sensing output 13	
16	C2D_TX14_A	Capacitive Sensing output 14	
17	C2D_TX15_A	Capacitive Sensing output 15	
18	C2D_RX00_A	Capacitive Sensing input 0	
19	C2D_RX01_A	Capacitive Sensing input 1	
20	C2D_RX02_A	Capacitive Sensing input 2	
21	C2D_RX03_A	Capacitive Sensing input 3	
22	C2D_RX04_A	Capacitive Sensing input 4	
23	C2D_RX05_A	Capacitive Sensing input 5	
24	C2D_RX06_A	Capacitive Sensing input 6	
25	C2D_RX07_A	Capacitive Sensing input 7	
26	C2D_RX08_A	Capacitive Sensing input 8	
27	C2D_RX09_A	Capacitive Sensing input 9	
28	C2D_RX10_A	Capacitive Sensing input 10	
29	C2D_RX11_A	Capacitive Sensing input 11	
30	C2D_RX12_A	Capacitive Sensing input 12	
31	C2D_RX13_A	Capacitive Sensing input 13	
32	C2D_RX14_A	Capacitive Sensing input 14	
33	C2D_RX15_A	Capacitive Sensing input 15	
34	GND		
35	ADC_VREF	ADC voltage reference	PB0.12
36	ADC_VREFGND	ADC VREF ground	PB0.11
37	ADC_IN0		PB1.5H

# UDP SiM3U1xx

Table 11. UDP SiM3U1xx Card H4 Pin Descriptions (J4) (Continued)

MCU Card Pin	Description	Description	SiM3U167 Pin / Signal
38	ADC_IN1		PB1.6H
39	ADC_IN2		PB1.10
40	ADC_IN3		PB1.11
41	GND		
42	DAC_VREF	DAC voltage reference	
43	DAC_VREFGND	DAC voltage reference ground	
44	DAC_OUT0		
45	DAC_OUT1		
46	DAC_OUT2		
47	DAC_OUT3		
48	GND		
49	IDAC_A	IDAC A output	PB0.14
50	IDAC_B	IDAC B output	PB0.13
51	CP_OUT_A	Comparator A synchronous output	PB0.15H
52	CP_OUTA_A	Comparator A asynchronous output	PB1.0H
53	CP_POS_A	Comparator A positive input	PB2.13
54	CP_NEG_A	Comparator A negative input	PB2.14
55	CP_POS_B	Comparator B positive input	PB3.4
56	CP_NEG_B	PB3.5	
57	GND		
58	HVDA_INP_A	High Voltage Differential Amplifier A positive input	
59	HVDA_INN_A	High Voltage Differential Amplifier A negative input	
60	HVDA_INP_B	High Voltage Differential Amplifier B positive input	
61	HVDA_INN_B	High Voltage Differential Amplifier B negative input	
62	GND		
63	I2V_INP_A	Current-to-Voltage converter A input 0	PB0.7
64	I2V_INN_A	Current-to-Voltage converter A input 1	PB0.8
65	EXTREG_SP_A	External Voltage Regulator SP input	PB3.6
66	EXTREG_SN_A	External Voltage Regulator SN input	PB3.7
67	EXTREG_OUT_A	External Voltage Regulator OUT output	PB3.8
68	EXTREG_BD_A	External Voltage Regulator base drive output	PB3.9
69	GND		
70	EZRP_CLK_IN	Radio test card clock input (SMA connector)	PB1.14
71	GND		
72	EZRP_TX_DATA_IN	Radio test card transmit data input (SMA connector)	PB1.15
73	EZRO_RX_CLK_OUT	Radio test card receive clock output (SMA connector)	PB2.0
74	EZRP_RX_DATA_OUT	Radio test card receive data output (SMA connector)	PB2.1

**Table 11. UDP SiM3U1xx Card H4 Pin Descriptions (J4) (Continued)**

MCU Card Pin	Description	Description	SiM3U167 Pin / Signal
75	GND		
76	EZRP_SDN	Radio test card peripheral shutdown	PB2.2
77	EZRP_NIRQ	Radio test card peripheral interrupt status	PB2.3
78	EZR_NFFS		
79	EZR_SI100X_TX	Radio test card Si100x transmit	
80	EZR_DTO		
81	EZR_FFIT		
82	EZR_SI100X_RX	Radio test card Si100x receive	
83	EZR_RESET	Radio test card reset	
84	EZR_ARSSI		
85	EZR_VDI		
86	EZR_GPIO0	Radio test card general purpose I/O 0	
87	EZR_GPIO1	Radio test card general purpose I/O 1	
88	EZR_GPIO2	Radio test card general purpose I/O 2	
89	EZR_GPIO3	Radio test card general purpose I/O 3	
90	EZR_GPIO4	Radio test card general purpose I/O 4	
91	H4_91	General purpose signal	
92	ITM_DAT0		
93	ITM_DAT1		
94	ITM_DAT2		
95	ITM_DAT3		
96	ITM_CLK		
97	H4_97	General purpose signal	
98	H4_98	General purpose signal	
99	H4_99	General purpose signal	
100	GND		

## DOCUMENT CHANGE LIST:

### Revision 0.1 to Revision 0.2

- Added section 3.4
- Added step 13 in section 3.2

**NOTES:**

# UDP SiM3U1xx

---

## CONTACT INFORMATION

Silicon Laboratories Inc.  
400 West Cesar Chavez  
Austin, TX 78701

Please visit the Silicon Labs Technical Support web page:

<http://www.silabs.com/support>

and register to submit a technical support request.

The information in this document is believed to be accurate in all respects at the time of publication but is subject to change without notice. Silicon Laboratories assumes no responsibility for errors and omissions, and disclaims responsibility for any consequences resulting from the use of information included herein. Additionally, Silicon Laboratories assumes no responsibility for the functioning of undescribed features or parameters. Silicon Laboratories reserves the right to make changes without further notice. Silicon Laboratories makes no warranty, representation or guarantee regarding the suitability of its products for any particular purpose, nor does Silicon Laboratories assume any liability arising out of the application or use of any product or circuit, and specifically disclaims any and all liability, including without limitation consequential or incidental damages. Silicon Laboratories products are not designed, intended, or authorized for use in applications intended to support or sustain life, or for any other application in which the failure of the Silicon Laboratories product could create a situation where personal injury or death may occur. Should Buyer purchase or use Silicon Laboratories products for any such unintended or unauthorized application, Buyer shall indemnify and hold Silicon Laboratories harmless against all claims and damages.

Silicon Laboratories and Silicon Labs are trademarks of Silicon Laboratories Inc.

Other products or brandnames mentioned herein are trademarks or registered trademarks of their respective holders.



## Стандарт Электрон Связь

Мы молодая и активно развивающаяся компания в области поставок электронных компонентов. Мы поставляем электронные компоненты отечественного и импортного производства напрямую от производителей и с крупнейших складов мира.

Благодаря сотрудничеству с мировыми поставщиками мы осуществляем комплексные и плановые поставки широчайшего спектра электронных компонентов.

Собственная эффективная логистика и склад в обеспечивает надежную поставку продукции в точно указанные сроки по всей России.

Мы осуществляем техническую поддержку нашим клиентам и предпродажную проверку качества продукции. На все поставляемые продукты мы предоставляем гарантию .

Осуществляем поставки продукции под контролем ВП МО РФ на предприятия военно-промышленного комплекса России , а также работаем в рамках 275 ФЗ с открытием отдельных счетов в уполномоченном банке. Система менеджмента качества компании соответствует требованиям ГОСТ ISO 9001.

Минимальные сроки поставки, гибкие цены, неограниченный ассортимент и индивидуальный подход к клиентам являются основой для выстраивания долгосрочного и эффективного сотрудничества с предприятиями радиоэлектронной промышленности, предприятиями ВПК и научно-исследовательскими институтами России.

С нами вы становитесь еще успешнее!

### Наши контакты:

**Телефон:** +7 812 627 14 35

**Электронная почта:** [sales@st-electron.ru](mailto:sales@st-electron.ru)

**Адрес:** 198099, Санкт-Петербург,  
Промышленная ул, дом № 19, литера Н,  
помещение 100-Н Офис 331