



BLUETOOTH® LOW ENERGY,

IEEE® 802.15.4

VOL KW41Z MODULE

PRODUCT DATA SHEET

REVISION V1R1



Copyright Info

The information contained in this document is the proprietary information of VOLANSYS Technologies Pvt., Ltd. The contents are confidential and any disclosure to persons other than the officers, employees, agents or subcontractors of the owner or licensee of this document, without the prior written consent of VOLANSYS, is strictly prohibited.

Further, no portion of this document may be reproduced, stored in a retrieval system, or transmitted in any form or by any means, electronic or mechanical, including photocopying and recording, without the prior written consent of VOLANSYS, the copyright holder.

VOLANSYS publishes this document without making any warranty as to the content contained herein. Further VOLANSYS reserves the right to make modifications, additions and deletions to this document due to typographical errors, inaccurate information, or improvements to products mentioned in the document at any time and without notice. Such changes will, nevertheless be incorporated into new editions of this document.

Table of content

1	DOCUMENT DETAILS	5
1.1	REVISION HISTORY	5
2	INTRODUCTION	6
3	PRODUCT OVERVIEW	7
4	MODULE PINOUTS.....	9
5	HARDWARE DESCRIPTION	14
5.1	HARDWARE BLOCK DIAGRAM	14
5.2	ANTENNA	15
5.3	MODULE RESET	15
5.4	CLOCK.....	15
5.5	DEBUG AND PROGRAMMING.....	16
6	ELECTRICAL CHARACTERISTICS	17
6.1	ABSOLUTE MAXIMUM RATINGS	17
6.2	RECOMMENDED (OPERATING CONDITION)	17
6.3	DC-DC CONVERTER	17
6.3.1	<i>Buck mode</i>	18
6.3.2	<i>Bypass Mode</i>	18
6.3.3	<i>Boost Mode</i>	18
6.4	DC ELECTRICAL CHARACTERISTICS	18
6.5	DIGITAL I/O SPECIFICATION	19
6.6	ANALOG AND VREF	19
6.7	RF CHARACTERISTICS	20
7	MODULE DIMENSION	21
7.1	KW41Z MODULE DIMENSION	21
7.2	RECOMMENDED PCB LAYOUT PATTERN.....	22
8	CERTIFICATIONS	23
9	REGULATORY STATEMENTS.....	24
9.1	FCC STATEMENT	24
9.2	FCC RADIATION EXPOSURE STATEMENT	24
9.3	ORIGINAL EQUIPMENT MANUFACTURER (OEM) NOTES	24
9.4	IC STATEMENT	25
9.5	CE REGULATORY	27
10	RECOMMENDED REFLOW PROFILE.....	28
11	APPLICATION NOTE	29
11.1	SAFETY PRECAUTIONS	29
11.2	DESIGN ENGINEERING NOTES	29
11.3	STORAGE CONDITIONS	29

11.4	SHIPMENT	30
11.5	HANDLING	30
12	APPENDIX-A	31
12.1	ACRONYMS & GLOSSARY	31

LIST OF FIGURES

Figure 1: Module Overview9
Figure 2: KW41Z Module Hardware Block Diagram14
Figure 3: KW41Z Module Physical Dimensions21
Figure 4: PCB Layout Pattern Dimensions.....22
Figure 5: Reflow Soldering Profile28

1 DOCUMENT DETAILS

1.1 Revision History

Rev.	Date	Description	Prepared By	Reviewed By	Approved By
V1R1	19-Sep-17	Final draft version released	VOLANSYS	VOLANSYS	VOLANSYS

2 INTRODUCTION

This document describes the VOLANSYS KW41Z module. Which has been designed to be easily integrated into another device and to provide fast and low cost proven wireless network.

The KW41Z module is ultra-compact, low power high sensitivity module. It is based on NXP's KW41Z512VHT4 SoC combined with Bluetooth Low energy and IEEE 802.15.4 network stacks like Thread, Zigbee pro etc.

No RF experience or expertise is required to add this powerful wireless networking capability to your products. This series of modules offer fast integration opportunities and the shortest possible time to market for your product.

3 PRODUCT OVERVIEW

The KW41Z Module is a fully self-contained, small form factor Bluetooth Low Energy 4.2 and IEEE 802.15.4 compliant module with low complexity and low power features. Based on NXP's Kinetis MCU wireless hardware platform, KW41Z offers superior low power radio performance.

The KW41Z module employs low power architecture and it has been optimized for all kind of application in home automation, smart grid, smart lighting, also networked building control, Medical equipment and Home automation application, HVAC and security.

For evaluation and development, VOLANSYS offers a complete set of evaluation and development tools. VOL KW41Z is also enriched with mikroBUS™ compatibility option to connect to third-party products in a single click.

Module Features

- Small form factor, SMT module 19mm x 11.51mm
- Integrated chip antenna
- Max output power: +3.5 dbm
- Typical Receiver Sensitivity (BLE) = -96 dBm
- Typical Receiver Sensitivity (802.15.4) = -100 dBm
- 32bit ARM® Cortex-M0+ MCU with 64K SRAM and 512K Flash
- Up to 48 MHz ARM® Cortex-M0+ core
- Integrated DC-DC converter enables a wide operating range from 0.9 V to 4.2 V
- Supports Buck and boost power mode with easy hardware configuration
- Extended Operation temp range: -40 °C to +105 °C
- Hardware supported encryption AES 128-bit, TRNG Supported
- 9 MCU Low-power modes to provide power optimization based on application requirements.
- Low Power Mode (VLLS0) Current: ≈180 nA
- All MCU pins accessible
- Serial wire debug(SWD) Interface and Micro Trace buffer
- On module 32MHz crystal
- External RTC 32KHz support
- RoHS compliant
- Peripheral Interfaces: 2xSPI, 1xUART, 2xI2C, CMT, SWD, 16-bit ADC, Timers

Suggested Applications

- Extremely low-power embedded systems
- Portable health care devices
- Wearable sports
- Fitness devices
- Computer keyboards and mice
- Gaming controllers
- Access control
- Security systems
- Smart energy
- Home area networks
- Automated meter reading
- Medical Network
- HVAC Control
- Lighting control
- Asset tracking
- Environment monitoring and control

4 MODULE PINOUTS

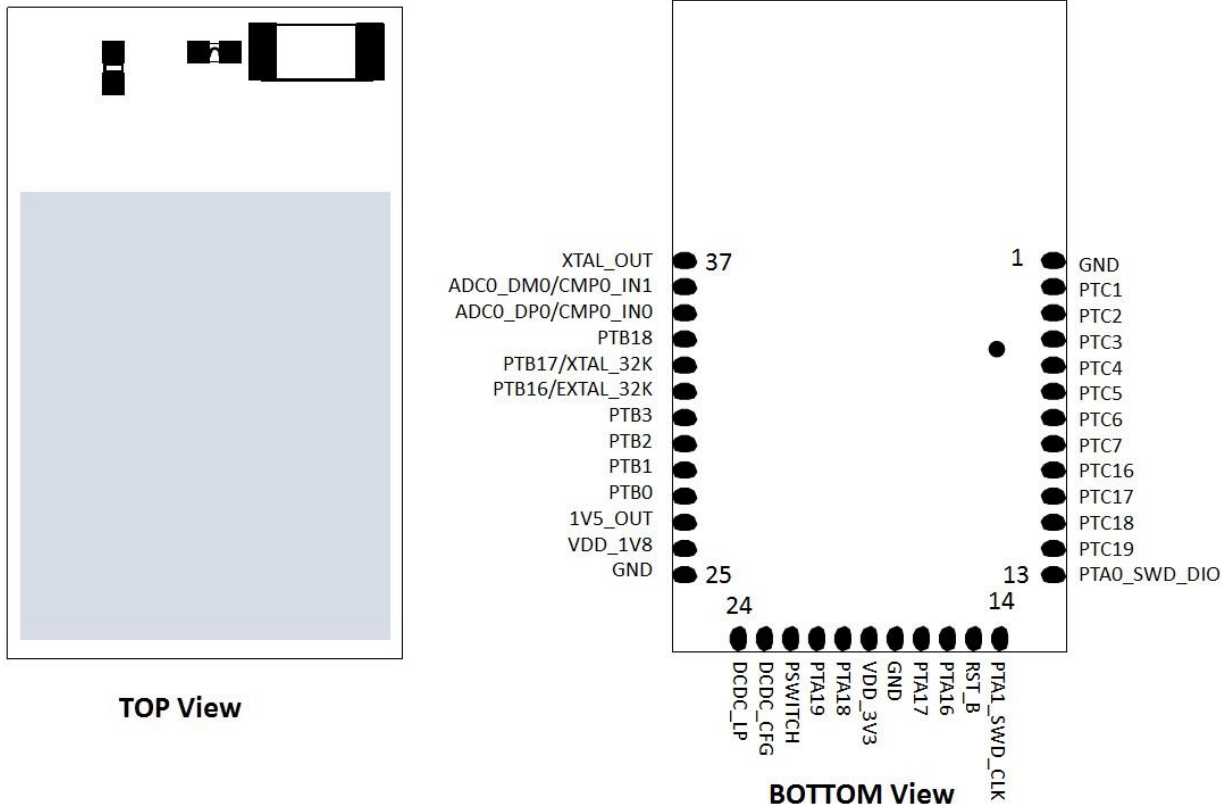

Figure 1: Module Overview

KW41Z module has 31 edge pin for connections as below:

Module PIN#	KW41Z512 PIN#	Name	Default Use	Alternate Function	Remarks
1	26, 49 to 64	GND			
2	37	PTC1	DISABLED	PTC1, ANT_B, I2CO_SDA, UART0_RTS_b, TPMO_CH2, RF_ACTIVE	
3	38	PTC2	DISABLED	TSIO_CH14/DIAG1, PTC2/LLWU_P10, TX_SWITCH, I2C1_SCL, UART0_RX, CMT_IRO, DTM_RX	
4	39	PTC3	DISABLED	TSIO_CH15/DIAG2,	

				PTC3/LLWU_P11, RX_SWITCH, I2C1_SDA, UART0_TX, TPM0_CH1, DTM_TX	
5	40	PTC4	DISABLED	TSIO_CH0/DIAG3, PTC4/LLWU_P12, ANT_A, EXTRG_IN, UART0_CTS_b, TPM1_CH0, BSM_DATA	
6	41	PTC5	DISABLED	TSIO_CH1/DIAG4, PTC5/LLWU_P13, RF_OFF, LPTMRO_ALT2, UART0_RTS_b, TPM1_CH1, BSM_CLK	
7	42	PTC6	DISABLED	TSIO_CH2, PTC6/LLWU_P14/XTAL_OUT_EN, I2C1_SCL, UART0_RX, TPM2_CH0, BSM_FRAME	
8	43	PTC7	DISABLED	TSIO_CH3, PTC7/LLWU_P15, SPIO_PCS2, I2C1_SDA, UART0_TX, TPM2_CH1, BSM_DATA	
9	45	PTC16	DISABLED	TSIO_CH4, PTC16/LLWU_P0, SPIO_SCK, I2C0_SDA, UART0_RTS_b, TPM0_CH3	
10	46	PTC17	DISABLED	TSIO_CH5, PTC17/LLWU_P1, SPIO_SOUT, I2C1_SCL, UART0_RX, BSM_FRAME, DTM_RX	
11	47	PTC18	DISABLED	TSIO_CH6, PTC18/LLWU_P2,	

				SPIO_SIN, I2C1_SDA, UART0_TX, BSM_DATA, DTM_TX	
12	48	PTC19	DISABLED	TSIO_CH7, PTC19/LLWU_P3, SPIO_PCS0, I2C0_SCL, UART0_CTS_b, BSM_CLK, RF_ACTIVE	
13	1	PTA0	SWD_DIO	TSIO_CH8, PTA0, SPIO_PCS1, TPM1_CHO, SWD_DIO	Provide 10K pull up
14	2	PTA1	SWD_CLK	TSIO_CH9, PTA1, SPI1_PCS0, TPM1_CH1, SWD_CLK	Provide 10K ohm pull-down
15	3	PTA2/ RESET_b	RESET_b	PTA2, TPM0_CH3, RESET_b	Provide 10K pull up
16	4	PTA16	DISABLED	TSIO_CH10 PTA16/LLWU_P4, SPI1_SOUT, TPM0_CHO	
17	5	PTA17	DISABLED	TSIO_CH11, PTA17/LLWU_P5/RF_RESET , SPI1_SIN, TPM_CLKIN1	
18	26, 49 to 64	GND	GND		
19	10, 8	VIN	Supply Input		
20	6	PTA18	DISABLED	TSIO_CH12, PTA18/LLWU_P6, SPI1_SCK, TPM2_CHO	
21	7	PTA19	DISABLED	TSIO_CH13/ADC0_SE5, PTA19/LLWU_P7, SPI1_PCS0, TPM2_CH1	
22	8	PSWITCH	VIN		
23	9	DCDC_CFG	DCDC_CFG		

24	11	DCDC_LP	DCDC_LP		
25	26, 49 to 64	GND	GND		
26	14	VDD_1P8OUT			
27	15	VDD_1P5OUT _PMCIN			
28	16	PTB0	DISABLED	PTB0/LLWU_P8/XTAL_OUT _EN, PTB0, I2CO_SCL, CMPO_OUT, TPMO_CH1, CLKOUT	
29	17	PTB1	DISABLED	ADCO_SE1/CMPO_IN5, PTB1, DTM_RX, I2CO_SDA, LPTMRO_ALT1, TPMO_CH2, CMT_IRO	
30	18	PTB2	DISABLED	ADCO_SE3/CMPO_IN3, PTB2, RF_OFF, DTM_TX, TPM1_CH0	
31	19	PTB3	DISABLED	ADCO_SE2/CMPO_IN4, PTB3, CLKOUT, TPM1_CH1, RTC_CLKOUT	
32	21	EXTAL32K	EXTAL32K	EXTAL32K, PTB16, I2C1_SCL, TPM2_CH0	
33	22	XTAL32K	XTAL32K	XTAL32K, PTB17, I2C1_SDA, TPM2_CH1, BSM_CLK	
34	23	PTB18	NMI_b	DACO_OUT/ADCO_SE4/CM PO_IN2, PTB18, I2C1_SCL, TPM_CLKINO, TPMO_CH0, NMI_b	

35	24	ADC0_DP0	ADC0_DP0 / CMPO_IN0	ADC0_DP0 / CMPO_IN0	
36	25	ADC0_DM0	ADC0_DM0 / CMPO_IN1	ADC0_DM0/ CMPO_IN1	
37	29	XTAL_OUT	XTAL_OUT		

Note:

- Provided pull up at **Reset_b** pin.
- Provide Pull down at **SWD_CLK** pin.
- Provide Pull up at **SWD_DIO** pin.

5 HARDWARE DESCRIPTION

5.1 Hardware Block Diagram

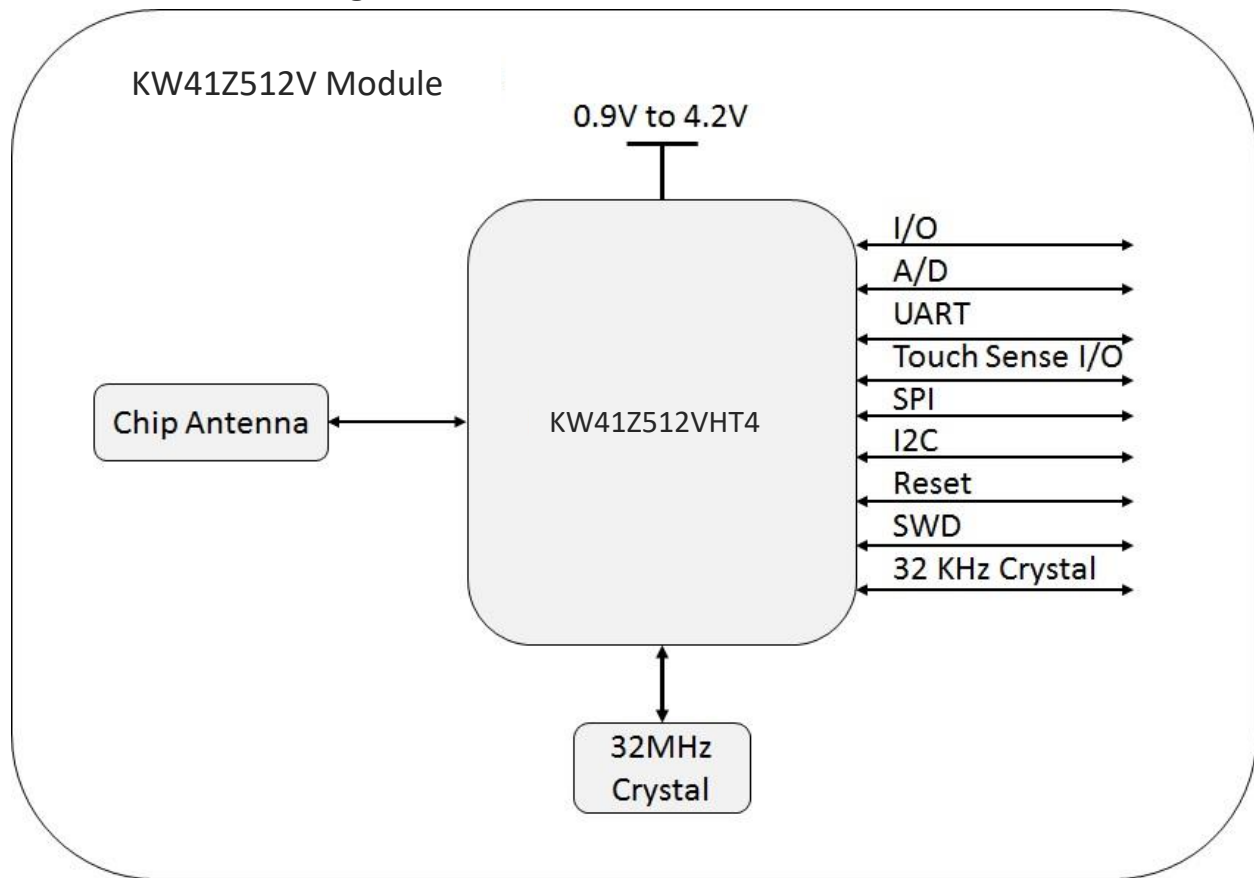

Figure 2: KW41Z Module Hardware Block Diagram

The KW41Z512 Module families are based on the NXP's Kinetis MCU family KW41Z512VHT4. KW41Z module are fully integrated 2.4GHz Bluetooth Low Energy (BLE 4.2) and IEEE 802.15.4 compliant transceiver and a powerful 32-bit ARM® Cortex M0+ MCU, up to 512kB flash and 128kB SRAM memory and rich peripherals. The industry standard Micro trace buffer and serial wire SWD programming and debugging interfaces together with the standard ARM system debug components help to streamline any custom software development.

Module has inbuilt chip antenna. These antenna supports BLE and IEEE 802.15.4 protocol ISM Band (2.4GHz). The voltages are monitored (brown-out detection) and the built in power-on-reset circuit eliminates the need for any external monitoring circuitry. This module has support of external RTC 32/32.768 kHz watch crystal. The KW41Z512 module have fully integrated DC-DC converter with Buck, Boost and Bypass modes. Module can be easily configured for Buck and Boost mode power operations. For more details please check DCDC converter section.

5.2 Antenna

The KW41Z Module includes an integrated chip antenna. The KW41Z Module should be mounted with the PCB chip antenna overhanging the edge of the host board. To further improve performance, a ground plane may be placed on the host board under the module up to the antenna keep out area. The installation of an uninterrupted ground plane on a layer directly beneath the module will also allow you to run traces under this layer.

The chip antenna is compact and highly efficient. To maximize range, an adequate ground plane must be provided on the host PCB. Correctly positioned, the ground plane on the host PCB will contribute significantly to the antenna performance; it should not be directly under the chip antenna. The position of the module on the host board and overall design of the product enclosure contribute to antenna performance. Poor design affects radiation patterns and can result in reflection, diffraction and/or scattering of the transmitted signal.

A few design guidelines to help ensure antenna performance:

- Never place the ground plane or route copper traces directly underneath the antenna portion of the module
- Never place the antenna close to metallic objects
- In the overall design, ensure that wiring and other components are not placed near the antenna
- Do not place the antenna in a metallic or metalized plastic enclosure
- Keep plastic enclosures 1cm or more away from the antenna in any direction

5.3 Module Reset

Pin 15 is used as an external reset. The reset pin only contains an active pull down device. This pin can be used for other functions, such as GPIO, by setting the RESET_PIN_CFG option bit of the FTFA_FPORT register to 0. This bit is retained through system resets and low power modes. When the RESET pin is disabled and configured as a GPIO output, it operates as a pseudo open drain output.

5.4 Clock

The KW41Z Module requires two clock system.

On module 32MHz crystal used for RF reference oscillator. The clock is used by the RF, analog and digital section interfaces. It can be used also by the MCU core and as a clock source for some internal peripherals. For normal run modes, an internal oscillator can provide the low frequency clock. However, to make full use of reduced power modes an external crystal must be present.

The KW41Z Module supports external 32/32.768KHz crystal. This is used as the clock for the RTC and the deep-sleep clock.

Symbol	Parameter	Typ.	Max.	Unit
FNOM_LFXO	Crystal frequency	32/32.768	-	KHz
FTOL_LFXO_BLE	Frequency tolerance, BLE applications	±20	±250	ppm
CL_LFXO	Load Capacitance	7	12.5	pF

Note: External capacitors are not required for 32KHz crystal.

5.5 Debug and Programming

The KW41Z module supports the two pin Serial Wire Debug (SWD) interface and offers flexible mechanisms for non-intrusive debugging of program code. The R41Z also supports Micro Trace Buffer (MTB) which provides a lightweight program trace capabilities using system RAM.

6 ELECTRICAL CHARACTERISTICS

6.1 Absolute Maximum Ratings

The absolute maximum ratings given below should under no circumstances be violated. Exceeding one or more of the limiting values may cause permanent damage to the device.

Description	Module		Unit
	Min	Max	
Power Supply Voltage (VIN)	-0.3	4.2	V
Voltage on I/O line	-0.3	VDD+0.3	V
RF Input power	-	+3.5	dbm
Storage temperature	-40	105	°C

6.2 Recommended (Operating Condition)

Description	Module			Unit
	Min	Typ	Max	
Bypass Mode Supply Voltage(Digital) (VIN)	1.71	-	3.6	V
Boost Mode Supply Voltage (VIN)	0.9	-	1.795	V
Buck Mode Supply Voltage (VIN) ¹	2.1	-	4.2	V
RF Input Frequency	2360	-	2480	MHz
RF Output Power	-	-	3.5	dBm
SPI Clock Rate	-	-	12.0	MHz
Logic Input High voltage	0.7*VDD_1V8 ³	-	-	V
Logic Input Low voltage	-	-	0.3*VDD_1V8	V
DC-DC Converter Output Power	-	-	125	mW
Ambient temperature	-40	25	105	°C

Note:

1. In Buck mode, DC-DC converter needs 2.1V min to start, the supply can drop to 1.8V after DC-DC converter settles
2. Analog supply voltage is same as VDD_IO (VDD_1P8OUT)
3. VDD_1V8 is internal configurable LDO output referred as VDD_1P8OUT.

6.3 DC-DC Converter

The KW41Z module contains an integrated DCDC converter which allows for three modes of operation without additional components. When operating in DCDC Buck mode, power consumption from using the radio can be reduced compared to DCDC Bypass mode. DCDC Boost mode allows the use of a single alkaline or other low voltage source. While it is possible to switch between these modes in a single design.

6.3.1 Buck mode

Pin No#	Net name	Connection
19	Power Supply Voltage (VIN)	1.8V - 4.2V VIN
23	DCDC_CFG	1.8V - 4.2V VIN
24	DCDC_LP	NC
22	PSWITCH ¹	1.8V - 4.2V VIN
26	V1P8	NC / 1.8V - 3.0 Output voltage ²
27	V1P5	NC

Note 1: DCDC converter enables once PSWITCH connected with VIN supply. Once DCDC converter started PSWITCH can be reconnected to GND without disrupting the DCDC converter operation.

Note 2: While DCDC converter is running in either Buck or boost mode, V1P8 is I/O level for KW41Z. In Buck mode, V1P8 cannot output voltage greater than VIN supply voltage. V1P8 can provide a limited number of additional peripheral devices which connect directly to the KW41Z's IO due to low output current. Please refer KW41Z datasheet for output current.

6.3.2 Bypass Mode

Pin No#	Net name	Connection
19	Power Supply Voltage (VIN)	1.71V - 3.6V VIN
23	DCDC_CFG	1.71V - 3.6V VIN
24	DCDC_LP	NC
22	PSWITCH	Ground
26	V1P8	1.71V - 3.6V VIN
27	V1P5	1.45V - 3.6V VIN

6.3.3 Boost Mode

Pin No#	Net name	Connection
19	Power Supply Voltage (VIN)	0.9V - 1.8V VIN
23	DCDC_CFG	Ground
24	DCDC_LP	0.9V - 1.8V VIN
22	PSWITCH	0.9V - 1.8V VIN
26	V1P8 Out	NC / 1.8V - 3.0V Output voltage ¹
27	V1P5	NC

Note 1: While DCDC converter is running in either Buck or boost mode, V1P8 is I/O level for KW41Z. V1P8 can provide a limited number of additional peripheral devices which connect directly to the KW41Z's IO due to low output current. Please refer KW41Z datasheet for output current.

6.4 DC Electrical Characteristics

Buck Mode, VIN=3.6V, Tamb = 25°C, unless otherwise Specified

Description	Module			Unit
	Min	Typ	Max	
Transmit mode current @ +TBDdBm	-	TBD	-	mA
Receive mode current @max sensitivity	-	TBD	-	mA

Idle mode- Normal run, CPU at 48MHz		4		mA
-------------------------------------	--	---	--	----

Please Note:

- The average current consumption during operation is dependent on the firmware and the network load.

6.5 Digital I/O Specification

Digital I/Os of KW41Z512 Module, VIN = 3.3V, Tamb = 25°C, unless otherwise Specified

Symbol	Description	Module			Unit
		Min	Typ	Max	
VOH	Output high voltage — high drive strength • 2.7 V ≤ VDD ≤ 3.6 V, IOH = -20 mA • 1.71 V ≤ VDD ≤ 2.7 V, IOH = -10 mA	VDD-0.5	-	-	V
	Output high voltage — low drive strength • 2.7 V ≤ VDD ≤ 3.6 V, IOH = -5 mA • 1.71 V ≤ VDD ≤ 2.7 V, IOH = -2.5 mA	VDD-0.5	-	-	V
IOHT	IOHT Output high current total for all ports	-	-	100	mA
VOL	Output low voltage — high drive strength • 2.7 V ≤ VDD ≤ 3.6 V, IOL = 20 mA • 1.71 V ≤ VDD ≤ 2.7 V, IOL = 10 mA	-	-	0.5	V
	Output low voltage — low drive strength • 2.7 V ≤ VDD ≤ 3.6 V, IOL = 5 mA • 1.71 V ≤ VDD ≤ 2.7 V, IOL = 2.5 mA	-	-	0.5	V
VOLT	IOLT Output low current total for all ports	-	-	100	mA
RESET_b	Reset Pulse width to guarantee a reset	100	-	-	ns

6.6 Analog and VREF

The ADC analog system V_{DDA} powered with 1.8V supply through filtering circuit onboard the KW41Z module. The voltage reference VREF, has two sourcing options: internal and external supply. When externally supplied, VREF should be referenced to V_{DDA}. And for internal reference voltage, buffered reference is available internally for use with on chip peripherals such as ADCs and DACs. The Voltage Reference output can be trimmed with a resolution of 0.5mV

Symbol	Description	Module			Unit
		Min	Typ	Max	
V _{DDA}	Analog supply voltage	1.71	1.8	1.8	V
V _{REFH}	ADC reference voltage high	1.13	V _{DDA}	V _{DDA}	V
V _{REF_OUT}	Voltage reference output	1.19	1.195	1.2	V
V _{ADIN}	16-bit differential mode	GND		31/32 × V _{REFH}	V

	All other modes	GND		V_{REFH}	V
V_{AIN}	Analog input voltage	GND - 0.3		VDD	V
V_{AIO}	Analog input offset voltage	-	-	20	mV
I_{DDHS}	Supply current, High-speed mode	-	-	200	μ A
I_{DDL5}	Supply current, low-speed mode	-	-	20	μ A
V_{CMPOh}	Comparator output high	VDD - 0.5	-	-	V
V_{CMPOl}	Comparator output low	-	-	0.5	V

6.7 RF Characteristics

Description	Module			Unit
	Min	Typ	Max	
RF Frequency range	2400	-	2483.5	MHz
Tx Power	-30	-	+3.5	dBm
BLE Rx Sensitivity	-	-96	-	dBm
IEEE 802.15.4 Rx Sensitivity	-	-100	-	dBm
GFSK Rx Sensitivity (250 kbps GFSK-BT=0.5, h=0.5)	-	-100	-	dBm

7 MODULE DIMENSION

7.1 KW41Z Module Dimension

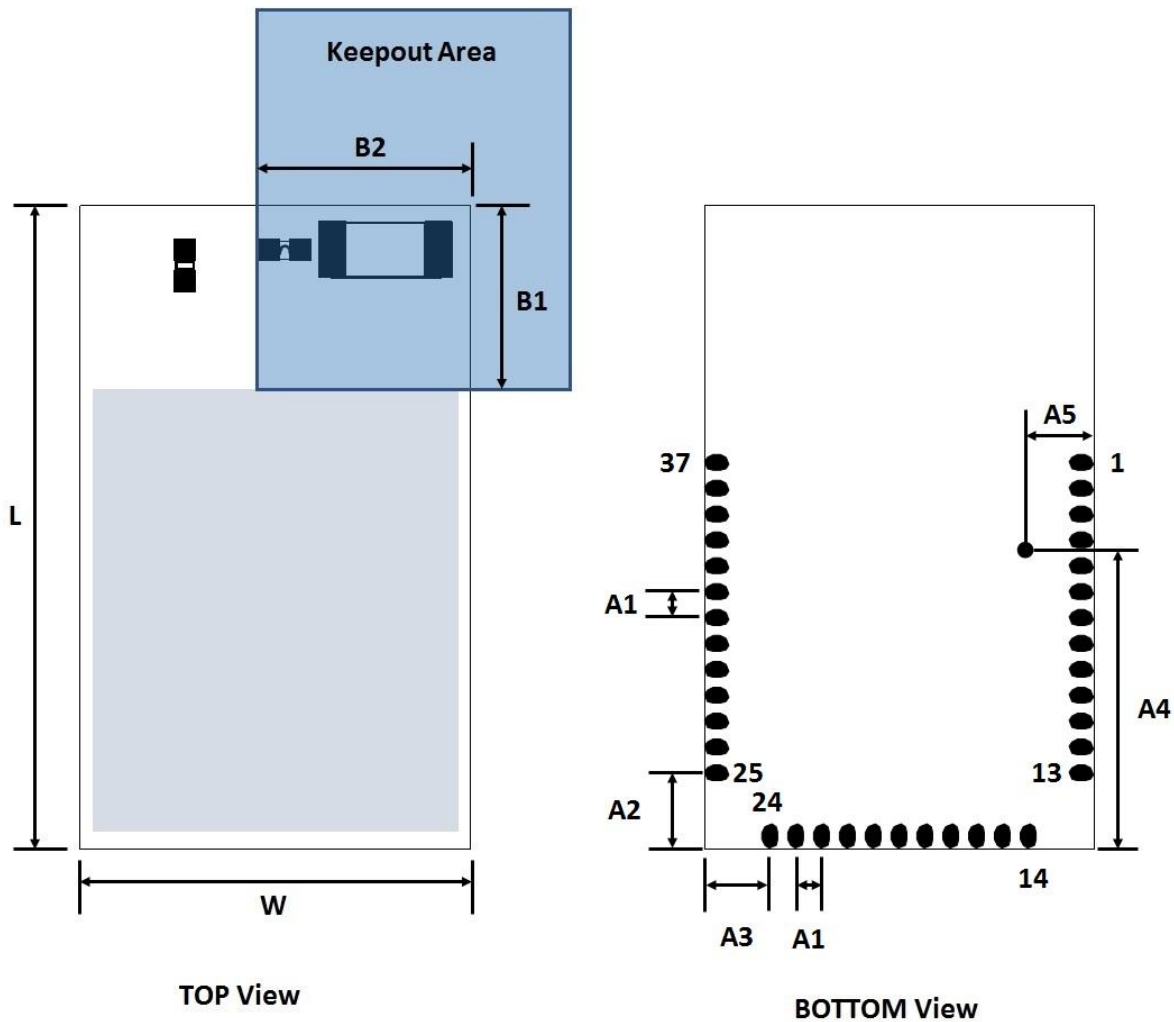

Figure 3: KW41Z Module Physical Dimensions

Symbol	Description	Typical Distance
L	Length of Module	19mm
W	Width of Modules	11.51mm
A1	SMD pad pitch	0.762mm
A2	Distance between board edge to center of pad	2.26mm
A3	Distance between board edge to center of pad	1.943mm
A4	Circular pad keepout from board edge	8.84mm
A5	Circular pad keepout from board edge	2mm
A	Keepout circular pad size	0.3mm
B1	Keepout zone from corner of PCB	6.5mm

B2	Keepout zone from corner of PCB	6.5mm
B x37	Rectangular SMD Pad size (All Pads are placed on board edges)	0.76mm x 0.50mm

For ideal RF performance when using the on-board antenna, the antenna should be located at the corner of the carrier PCB. There should be no components, tracks or copper planes in the Keep-out area which should be as large as possible.

When placing the module please either locate the antenna in the corner edge of PCB. So that the recommended antenna keep out zone is being followed, or add a no copper zone as mentioned keep out area.

7.2 Recommended PCB layout pattern

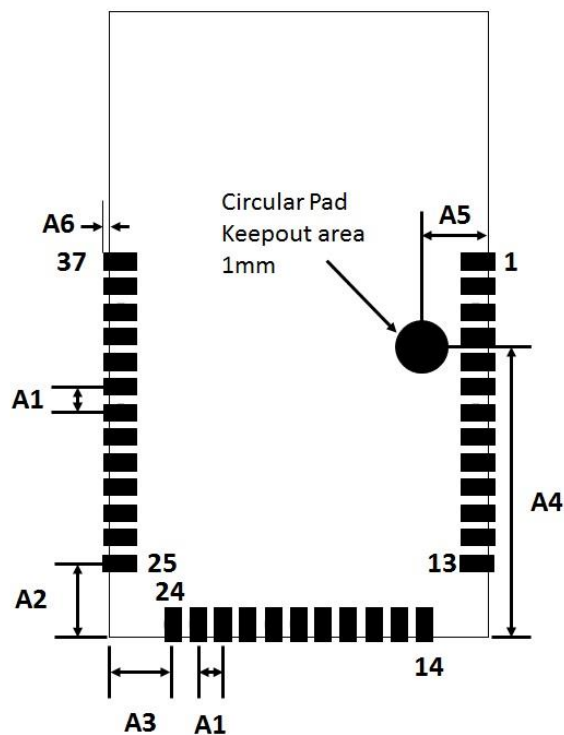

Figure 4: PCB Layout Pattern Dimensions

Symbol	Description	Typical Distance
A1	SMD pad pitch	0.762mm
A2	Distance between board edge to center of pad	2.26mm
A3	Distance between board edge to center of pad	1.94mm
A4	Circular pad keep-out from board edge	8.84mm
A5	Circular pad keep-out from board edge	2mm
A	circular pad Keepout area	1mm
B1	Keepout zone from corner of PCB	6.5mm
B2	Keepout zone from corner of PCB	6.5mm
B x37	Rectangular SMD Pad size (All Pads are placed on board edges)	1mm x 0.50mm

8 CERTIFICATIONS

FCC: FCC part 15 modular certification ID: 2AKNO-KW41Z

IC: Industry Canada RSS-247 modular certification IC:22256-KW41Z

CE: EN 60950-1: 2006 + A11 :2009 + A1:2010 + A12:2011 + A2:2013

EN 301 489-1 V2.2.0 (2017-03)

EN 301 489-17 V3.2.0 (2017-03)

EN 300 328 V2.1.1

9 REGULATORY STATEMENTS

9.1 FCC STATEMENT

1. This device complies with Part 15 of the FCC Rules. Operation is subject to the following two conditions:

- (1) This device may not cause harmful interference.
- (2) This device must accept any interference received, including interference that may cause undesired operation.

2. Changes or modifications not expressly approved by the party responsible for compliance could void the user's authority to operate the equipment.

NOTE: This equipment has been tested and found to comply with the limits for a Class B digital device, pursuant to Part 15 of the FCC Rules. These limits are designed to provide reasonable protection against harmful interference in a residential installation.

This equipment generates uses and can radiate radio frequency energy and, if not installed and used in accordance with the instructions, may cause harmful interference to radio communications.

However, there is no guarantee that interference will not occur in a installation. If this equipment does cause harmful interference to radio or television reception, which can be determined by turning the equipment off and on, the user is encouraged to try to correct the interference by one or more of the following measures:

- Reorient or relocate the receiving antenna.
- Increase the separation between the equipment and receiver.
- Connect the equipment into an outlet on a circuit different from that to which the receiver is connected.
- Consult the dealer or an experienced radio/TV technician for help.

9.2 FCC Radiation Exposure Statement

This equipment complies with FCC radiation exposure limits set forth for an uncontrolled environment. This equipment should be installed and operated with minimum distance 20cm between the radiator & your body

9.3 ORIGINAL EQUIPMENT MANUFACTURER (OEM) NOTES

- The OEM must certify the final end product to comply with unintentional radiators (FCC Sections 15.107 and 15.109) before declaring compliance of the final product to Part 15 of the FCC rules and regulations. Integration into devices that are directly or indirectly connected to AC lines must add with Class II Permissive Change.

- The OEM must comply with the FCC labeling requirements. If the module's label is not visible when installed, then an additional permanent label must be applied on the outside of the finished product which states: "Contains transmitter module FCC ID: 2AKNO-KW41Z Additionally, the following statement should be included on the label and in the final product's user manual: "This device complies with Part 15 of the FCC Rules. Operation is subject to the following two conditions: (1) This device may not cause harmful interferences, and (2) this device must accept any interference received, including interference that may cause undesired operation."
- The module is limited to installation in mobile or fixed applications. Separate approval is required for all other operating configurations, including portable configuration with respect to Part 2.1093 and different antenna configurations.
- module or modules can only be used without additional authorizations if they have been tested and granted under the same intended end-se operational conditions, including simultaneous transmission operations. When they have not been tested and granted in this manner, additional testing and/or FCC application filing may be required. The most straightforward approach to address additional testing conditions is to have the grantee responsible for the certification of at least one of the modules submit a permissive change application. When having a module grantee file a permissive change is not practical or feasible, the following guidance provides some additional options for host manufacturers. Integrations using modules where additional testing and/or FCC application filing(s) may be required are: (A) a module used in devices requiring additional RF exposure compliance information (e.g., MPE evaluation or SAR testing); (B) limited and/or split modules not meeting all of the module requirements; and (C) simultaneous transmissions for independent collocated transmitters not previously granted together.

This Module is full modular approval; it is limited to OEM installation ONLY.

Integration into devices that are directly or indirectly connected to AC lines must add with Class II Permissive Change.

(OEM) Integrator must assure compliance of the entire end product include the integrated Module.

Additional measurements (15B) and/or equipment authorizations (e.g Verification) may need to be addressed depending on co-location or simultaneous transmission issues if applicable.

(OEM) Integrator is reminded to assure that these installation instructions will not be made available to the end user of the final host device.

9.4 IC Statement

This device complies with Industry Canada license-exempt RSS standard(s). Operation is subject to the following two conditions: (1) This device may not cause interference, and (2) This device must accept any interference, including interference that may cause undesired operation of the device. This device complies with RSS-247 of Industry Canada. Operation is subject to the condition that

this device does not cause harmful interference. This Class B digital apparatus complies with Canadian ICES-003 (Cet appareil numérique de la Classe B conforme à la norme NMB-003 du Canada).

This equipment(IC:22256-KW41Z) complies with IC radiation exposure limits set forth for an uncontrolled environment. This equipment should be installed and operated with minimum distance of 20 cm between the radiator and your body. This transmitter must not be co-located or operating in conjunction with any other antenna or transmitter.

Le présent appareil est conforme aux CNR d'Industrie Canada applicables aux appareils radio exempts de licence. L'exploitation est autorisée aux deux conditions suivantes : (1) l'appareil ne doit pas produire de brouillage, et (2) l'utilisateur de l'appareil doit accepter tout brouillage radioélectrique subi, même si le brouillage est susceptible d'en compromettre le fonctionnement.

Cet équipement (IC: 22256-KW41Z) est conforme aux limites IC d'exposition aux radiations définies pour un environnement non contrôlé. Cet équipement doit être installé et utilisé avec une distance minimale de 20 cm entre le radiateur et votre corps. Cet émetteur ne doit pas être situé ou opérant en conjonction avec une autre antenne ou émetteur.

Module Statement:

Any product for which Modular Approval (MA) or Limited Modular Approval (LMA) is being sought shall meet the above labelling requirements (Section 3.1).

The Host Marketing Name (HMN) must be displayed (according to e-labelling requirements) or indicated at any location on the exterior of the host product or product packaging or product literature, which shall be available with the host product or online.

The host product shall be properly labelled to identify the modules within the host product.

The Innovation, Science and Economic Development Canada certification label of a module shall be clearly visible at all times when installed in the host product; otherwise, the host product must be labelled to display the Innovation, Science and Economic Development Canada certification number for the module, preceded by the word "Contains" or similar wording expressing the same meaning, as follows:

Contains IC: 22256-KW41Z

where 22256-KW41Z is the module's certification number.

The applicant for a certified module shall provide with each certified module to the user, either a host label, such as described above, or an explanation and instructions to the user as to the host product labelling requirements

9.5 CE Regulatory

Max RF power:

BLE (2402-2480MHz) : 3.8dBm

Thread (2400-2483.5MHz) : 3.1dBm

RF exposure information: The Maximum Permissible Exposure (MPE) level has been calculated based on a distance of d=20 cm between the device and the human body. To maintain compliance with RF exposure requirement, use product that maintain a 20cm distance between the device and human body.

Regulatory Conformance:

Hereby, VOLANSYS TECHNOLOGIES PVT. LTD. that the radio equipment type [VT-KW41Z] is in compliance with Directive 2014/53/EU.

EU declaration of conformity is available at the following internet address: www.VOLANSYS.com



Notice: Observe the national local regulations in the location where the device is to be used. This device may be restricted for use in some or all member states of the European Union (EU)

10 RECOMMENDED REFLOW PROFILE

Recommended Reflow Profile

Parameters Values	
Ramp Up Rate (from T soak max to T peak)	3°/sec max
Minimum Soak Temperature	150°C
Maximum Soak Temperature	200°C
Soak Time	90 ±30 sec
T Liquids	220°C
Time above TL	60-150 sec
T peak	250°C
Time within 5° of T peak	20-30 sec
Time from 25° to T peak	8 min max
Ramp Down Rate	6°C/sec max

Figure 5: Reflow Soldering Profile

Use of “No-Clean” solder paste is recommended to avoid the requirement for a cleaning process. Cleaning the module is strongly discouraged because it will be difficult to ensure no cleaning agent and other residuals are remaining underneath the shielding can as well as in the gap between the module and the host board.

Please Note:

Maximum number of reflow cycles: 2

Opposite-side reflow is prohibited: Do not place the module on the bottom / underside of your PCB and re-flow

11 APPLICATION NOTE

11.1 Safety Precautions

These specifications are intended to preserve the quality assurance of products as individual components. Before use, check and evaluate the module's operation when mounted on your products. Abide by these specifications when using the products. These products may short-circuit. If electrical shocks, smoke, fire, and/or accidents involving human life are anticipated when a short circuit occurs, then provide the following failsafe functions as a minimum:

- (1) Ensure the safety of the whole system by installing a protection circuit and a protection device.
- (2) Ensure the safety of the whole system by installing a redundant circuit or another system to prevent a single fault causing an unsafe status.

11.2 Design Engineering Notes

- (1) Heat is the major cause of shortening the life of the modules. Avoid assembly and use of the target equipment in conditions where the product's temperature may exceed the maximum allowable.
- (2) Failure to do so may result in degrading of the product's functions and damage to the product.
- (3) If pulses or other transient loads (a large load applied in a short time) are applied to the products, before use, check and evaluate their operation when assembled onto your products.
- (4) These products are not intended for other uses, other than under the special conditions shown below. Before using these products under such special conditions, check their performance and reliability under the said special conditions carefully, to determine whether or not they can be used in such a manner.
- (5) In liquid, such as water, salt water, oil, alkali, or organic solvent, or in places where liquid may splash. In direct sunlight, outdoors, or in a dusty environment. In an environment where condensation occurs. In an environment with a high concentration of harmful gas (ex. salty air, HCl, Cl₂, SO₂, H₂S, NH₃, and NO_x)
- (6) If an abnormal voltage is applied due to a problem occurring in other components or circuits, replace these products with new products because they may not be able to provide normal performance even if their electronic characteristics and appearances appear satisfactory.
- (7) Mechanical stress during assembly of the board and operation has to be avoided.
- (8) Pressing on parts of the metal cover or fastening objects to the metal cover is not permitted.

11.3 Storage Conditions

- (1) The module must not be stressed mechanically during storage.
- (2) Do not store these products in the following conditions or the performance characteristics of the product, such as RF performance, may well be adversely affected:
- (3) Storage in salty air or in an environment with a high concentration of corrosive gas, such as Cl₂, H₂S, NH₃, SO₂, or NO_x
- (4) Storage (before assembly of the end product) of the modules for more than one year after the date of delivery at your company even if all the above conditions (1) to (3) have been met, should be avoided.

11.4 Shipment

The KW41Z Modules are delivered in trays of **TBD**.

11.5 Handling

<**TBD**> The KW41Z Modules are designed and packaged to be processed in an automated assembly line.

12 APPENDIX-A

12.1 Acronyms & Glossary

The following terms are used in this document

Sr No#	Terms	Definition
1.	MCU	Microcontroller Unit
2.	CPU	Central Processing Unit
3.	BLE	Bluetooth Low Energy
4.	PWM	Pulse width Modulation
5.	ADC	Analog to Digital Convertor
6.	TBD	To Be Define
7.	MCU	Micro Controller Unit
8.	SRAM	Static Random Access Memory
9.	RTC	Real Time Clock
10.	NC	No Connection



Стандарт Электрон Связь

Мы молодая и активно развивающаяся компания в области поставок электронных компонентов. Мы поставляем электронные компоненты отечественного и импортного производства напрямую от производителей и с крупнейших складов мира.

Благодаря сотрудничеству с мировыми поставщиками мы осуществляем комплексные и плановые поставки широчайшего спектра электронных компонентов.

Собственная эффективная логистика и склад в обеспечивает надежную поставку продукции в точно указанные сроки по всей России.

Мы осуществляем техническую поддержку нашим клиентам и предпродажную проверку качества продукции. На все поставляемые продукты мы предоставляем гарантию .

Осуществляем поставки продукции под контролем ВП МО РФ на предприятия военно-промышленного комплекса России , а также работаем в рамках 275 ФЗ с открытием отдельных счетов в уполномоченном банке. Система менеджмента качества компании соответствует требованиям ГОСТ ISO 9001.

Минимальные сроки поставки, гибкие цены, неограниченный ассортимент и индивидуальный подход к клиентам являются основой для выстраивания долгосрочного и эффективного сотрудничества с предприятиями радиоэлектронной промышленности, предприятиями ВПК и научно-исследовательскими институтами России.

С нами вы становитесь еще успешнее!

Наши контакты:

Телефон: +7 812 627 14 35

Электронная почта: sales@st-electron.ru

Адрес: 198099, Санкт-Петербург,
Промышленная ул, дом № 19, литера Н,
помещение 100-Н Офис 331