



RM Cores

Series/Type: RM 5

The following products presented in this data sheet are being withdrawn.

Ordering Code	Substitute Product	Date of Withdrawal	Deadline Last Orders	Last Shipments
B65805C0000R026	B65805C0000R048	2002-08-02	2002-12-31	2003-03-31
B65805J0000Y042	B65805J0000Y066	2002-08-02	2002-12-31	2003-03-31
B65806K1004D002	B65806K1006D002	2003-08-08	2004-02-29	2004-08-31
B65539C1003X101	B65539C1003X001	2004-01-23		
B65806A50000000		2004-10-18	2005-03-31	2005-09-30
B65806A3002X022	B65806C3001X022	2003-08-08	2004-02-29	2004-08-31
B65539C1002X101	B65539C1003X001	2003-08-08	2004-02-29	2004-08-31

For further information please contact your nearest EPCOS sales office, which will also support you in selecting a suitable substitute. The addresses of our worldwide sales network are presented at www.epcos.com/sales.

- In accordance with IEC 60431
- Core without center hole for transformer applications
- RM cores are supplied in sets

Magnetic characteristics (per set)

	with center hole	without center hole	
$\Sigma l/A$	1,0	0,93	mm ⁻¹
l_e	20,8	22,1	mm
A_e	20,8	23,8	mm ²
A_{min}	—	18	mm ²
V_e	430	526	mm ³

Approx. weight (per set)

m	2,9	3,0	g

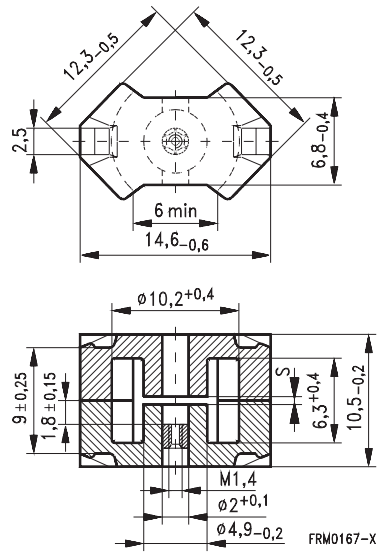
Gapped

Material	A_L value	s approx. mm	μ_e	Ordering code ¹⁾
	nH			-C with center hole -N with threaded sleeve
K1	25 ± 3 %	1,0	19,9	B65805-+25-A1
	40 ± 3 %	0,40	31,8	B65805-+40-A1
M33	63 ± 3 %	0,4	50,2	B65805-+63-A33
	100 ± 3 %	0,2	79,6	B65805-+100-A33
N48	160 ± 3 %	0,12	128	B65805-+160-A48
	250 ± 3 %	0,06	200	B65805-+250-A48
	315 ± 3 %	0,03	255	B65805-+315-A48

1) Replace the + by the code letter "C" or "N" for the required version.

Ungapped

Material	A_L value nH	μ_e	A_{L1min} nH	P_V W/set	Ordering code -C with center hole -J w/o center hole
N26	1800 + 30/- 20 %	1430			B65805-C-R26
T57 ¹⁾	2600 + 30/- 20 %	1920			B65805-J-R57
N30	3500 + 30/- 20 %	2590			B65805-J-R30
T38	6700 + 40/- 30 %	4960			B65805-J-Y38
T42	9600 + 40/- 30 %	7090			B65805-J-Y42
N49	1300 + 30/- 20 %	960	810	< 0,06 (50 mT, 500 kHz, 100 °C)	B65805-J-R49
N87	2000 + 30/- 20 %	1470	1200	< 0,32 (200 mT, 100 kHz, 100 °C)	B65805-J-R87
N97 ¹⁾	2000 + 30/- 20 %	1470	1200	< 0,24 (200 mT, 100 kHz, 100 °C)	B65805-J-R97
N41	2600 + 30/- 20 %	1920	1200	< 0,10 (200 mT, 100 kHz, 100 °C)	B65805-J-R41

1) Preliminary data

Coil former

Material: GFR thermosetting plastic (UL 94 V-0, insulation class to IEC 60085:
H \geq max. operating temperature 180 °C), color code blue

Solderability: to IEC 60068-2-20, test Ta, method 1 (aging 3): 235 °C, 2 s

Resistance to soldering heat: to IEC 60068-2-20, test Tb, method 1B: 350 °C, 3,5 s

Winding: see "Processing Notes", page 153

Pins squared in the start-of-winding area

For matching clamps and insulating washers see page 197

Sections	A _N mm ²	l _N mm	A _R value μΩ	Pins	Ordering code
1	9,5	25	90	4 5 6 8	B65806-K1004-D1 B65806-K1005-D1 B65806-K1006-D1 B65806-K1008-D1
2	8,7	25	94	4 5 6	B65806-K1004-D2 B65806-K1005-D2 B65806-K1006-D2

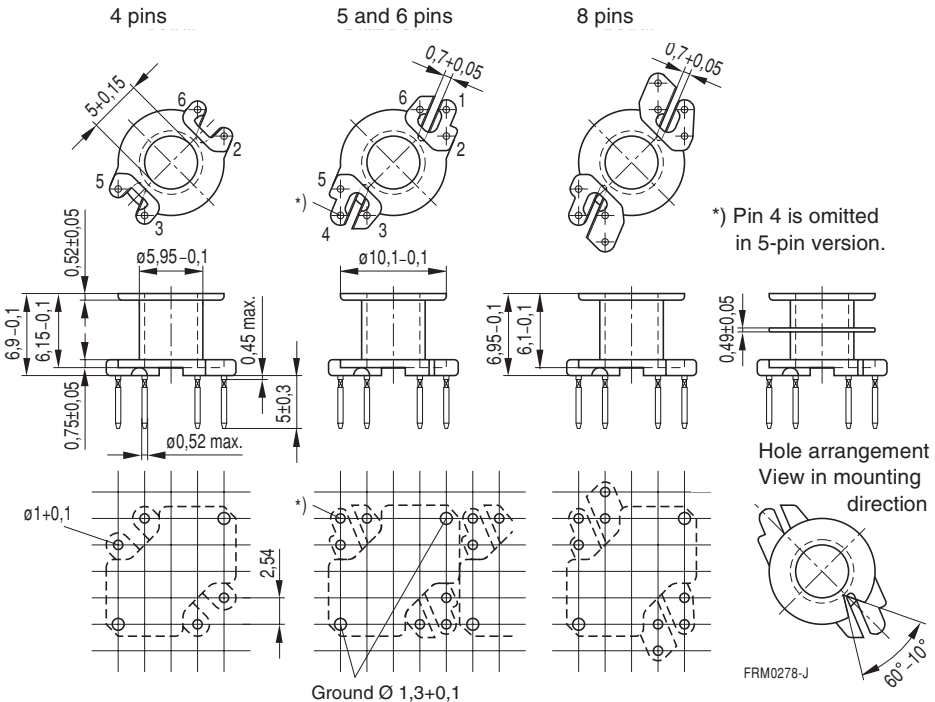

Clamp

- With ground terminal, made of stainless spring steel (tinned), 0,335 mm thick
- Solderability to IEC 60068-2-20, test Ta, method 1 (aging 3): 235 °C, 2 s
- Also available as strip clamp on reels

Insulating washer 1 between core and coil former

- For tolerance compensation and for insulation
- Made of polycarbonate (UL 94 V-0, insulation class to IEC 60085: E \triangleq 120 °C), 0,06 mm thick

Insulating washer 2 for double-clad PCBs

- Made of polycarbonate (UL 94 V-0, insulation class to IEC 60085: E \triangleq 120 °C), 0,3 mm thick

	Ordering code
Clamp (ordering code per piece, 2 are required)	B65806-A2203
Insulating washer 1 (reel packing, PU = 1 reel)	B65806-A5000
Insulating washer 2 (bulk)	B65806-D2005

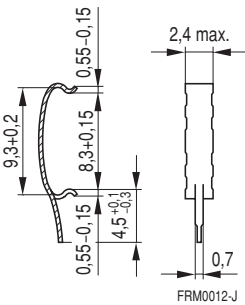
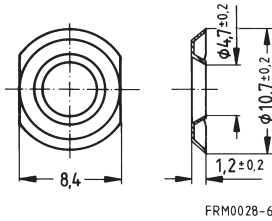
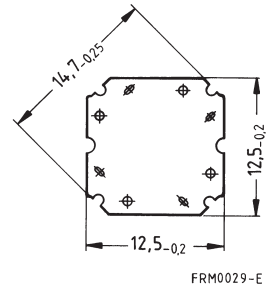
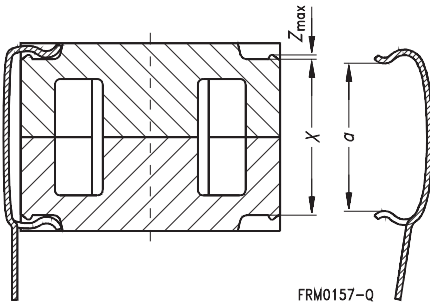
Clamp

Insulating washer 1

Insulating washer 2

Clamping forces for RM 5

F_{\min} : Extension of clamp from a to $a_2 = X_{\min}$
 F_{\max} : Extension of clamp from a to $a_1 = X_{\max}$

Clamp opening a (mm)		8,3 + 0,15
Core nose Z_{\max} (mm)		0,15
Height of core pair X (mm)	X_{\min}	8,75
	X_{\max}	9,25
Clamping force F (N)	F_{\min}	5
	F_{\max}	40



SMD coil former with gullwing terminals

Material: GFR liquid crystal polymer (UL 94 V-0, insulation class to IEC 60085:
F \triangleq max. operating temperature 155 °C), color code black

Solderability: to IEC 60068-2-20, test Ta, method 1 (aging 3): 350 °C, 1 s

Resistance to soldering heat: to IEC 60068-2-20, test Tb, method 1B: 350 °C, 3,5 s
permissible soldering temperature for wire-wrap connection on coil former: 400 °C, 1 s

Winding: see "Processing Notes", page 160

Clamp

- Without ground terminal, made of stainless spring steel, 0,335 mm thick
- Also available as strip clamp (each carton containing 2 reels) on request

Sections	A_N mm ²	l_N mm	A_R value $\mu\Omega$	Terminals	Ordering code
1	11,1	25	77	8	B65822-F1008-T1
2	10,2	25	85	8	B65822-F1008-T2
Clamp	(ordering code per piece, 2 are required)				B65806-J2204

Coil former

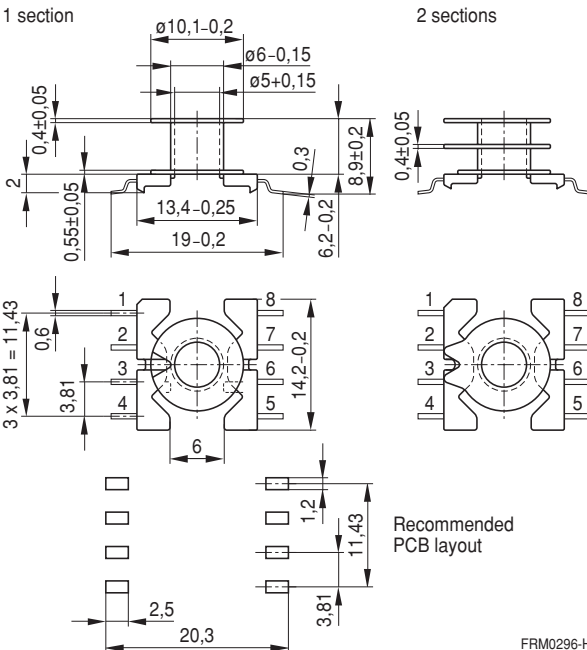

Clamp

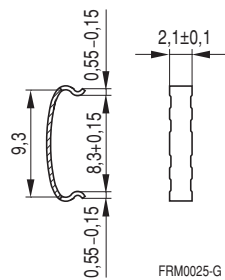

FRM0296-H



SMD coil former with J terminals

Material: GFR liquid crystal polymer (UL 94 V-0, insulation class to IEC 60085:
F \triangleq max. operating temperature 155 °C), color code black

Solderability: to IEC 60068-2-20, test Ta, method 1 (aging 3): 350 °C, 1 s

Resistance to soldering heat: to IEC 60068-2-20, test Tb, method 1B: 350 °C, 3,5 s
permissible soldering temperature for wire-wrap connection on coil former: 400 °C, 1 s

Winding: see "Processing Notes", page 160

Clamp

- Without ground terminal, made of stainless spring steel, 0,335 mm thick
- Also available as strip clamp (each carton containing 2 reels) on request

Sections	A_N mm ²	l_N mm	A_R value $\mu\Omega$	Terminals	Ordering code
1	11,1	25	73	8	B65822-J1008-T1
Clamp	(ordering code per piece, 2 are required)				B65806-J2204

Coil former

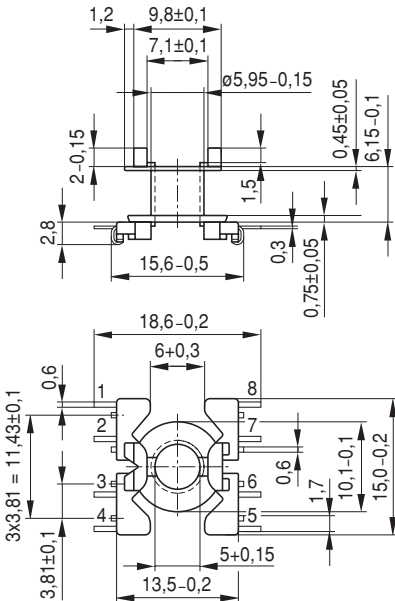

Clamp

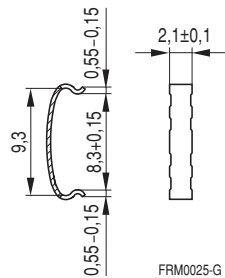

Recommended PCB layout

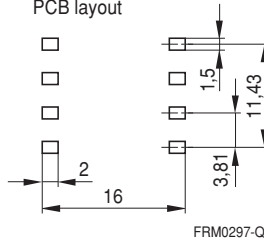

Adjusting screw

■ Tube core with thread and core brake made of GFR polyterephthalate

Plastic **adjusting screwdriver** (not shown)

Plastic **handle** for adjusting screwdriver (not shown)

Core RM 5		Adjusting screw				Min. adjusting range %	Ordering code
Material	A _L value nH	Fig.	Tube core ∅ × length mm	Material	Color code		
K 1	25	a	1,81 × 2,0	Si 1	black	13	B65539-C1003-X101
	40	a	1,81 × 2,0	K 1	yellow	16	B65539-C1003-X1
M 33	63	a	1,81 × 2,7	Si 1	white	11	B65539-C1002-X101
	100	a	1,81 × 2,0	K 1	yellow	14	B65539-C1003-X1
N 48	160	a	1,81 × 2,7	N 22	red	15	B65539-C1002-X22
	250 315	b	1,81 × 3,4	N 22	green	13 9	B65806-C3001-X22
	315	b	1,90 × 3,4	N 22	blue	12	B65806-A3002-X22
Adjusting screwdriver							B63399-B4
Handle							B63399-B5

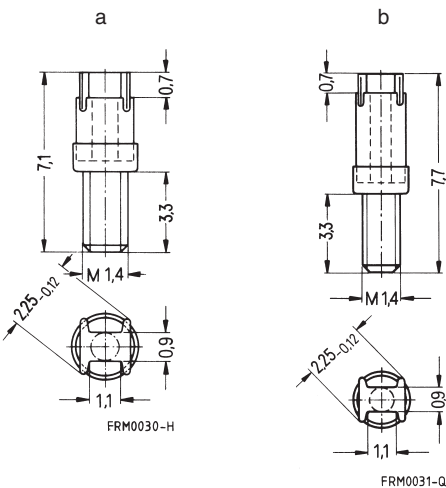
Adjusting screws

Herausgegeben von EPCOS AG

Marketing Kommunikation, Postfach 80 17 09, 81617 München, DEUTSCHLAND

© EPCOS AG 2000. Alle Rechte vorbehalten. Vervielfältigung, Veröffentlichung, Verbreitung und Verwertung dieser Broschüre und ihres Inhalts ohne ausdrückliche Genehmigung der EPCOS AG nicht gestattet.

Mit den Angaben in dieser Broschüre werden die Bauelemente spezifiziert, keine Eigenschaften zugesichert. Bestellungen unterliegen den vom ZVEI empfohlenen Allgemeinen Lieferbedingungen für Erzeugnisse und Leistungen der Elektroindustrie, soweit nichts anderes vereinbart wird.

Diese Broschüre ersetzt die vorige Ausgabe.

Fragen über Technik, Preise und Liefermöglichkeiten richten Sie bitte an den Ihnen nächstgelegenen Vertrieb der EPCOS AG oder an unsere Vertriebsgesellschaften im Ausland.

Bauelemente können aufgrund technischer Erfordernisse Gefahrstoffe enthalten. Auskünfte darüber bitten wir unter Angabe des betreffenden Typs ebenfalls über die zuständige Vertriebsgesellschaft einzuholen.

Published by EPCOS AG

Marketing Communications, P.O. Box 80 17 09, 81617 Munich, GERMANY

© EPCOS AG 2000. All Rights Reserved. Reproduction, publication and dissemination of this brochure and the information contained therein without EPCOS' prior express consent is prohibited.

The information contained in this brochure describes the type of component and shall not be considered as guaranteed characteristics. Purchase orders are subject to the General Conditions for the Supply of Products and Services of the Electrical and Electronics Industry recommended by the ZVEI (German Electrical and Electronic Manufacturers' Association), unless otherwise agreed.

This brochure replaces the previous edition.

For questions on technology, prices and delivery please contact the Sales Offices of EPCOS AG or the international Representatives.

Due to technical requirements components may contain dangerous substances. For information on the type in question please also contact one of our Sales Offices.



Стандарт Электрон Связь

Мы молодая и активно развивающаяся компания в области поставок электронных компонентов. Мы поставляем электронные компоненты отечественного и импортного производства напрямую от производителей и с крупнейших складов мира.

Благодаря сотрудничеству с мировыми поставщиками мы осуществляем комплексные и плановые поставки широчайшего спектра электронных компонентов.

Собственная эффективная логистика и склад в обеспечивает надежную поставку продукции в точно указанные сроки по всей России.

Мы осуществляем техническую поддержку нашим клиентам и предпродажную проверку качества продукции. На все поставляемые продукты мы предоставляем гарантию .

Осуществляем поставки продукции под контролем ВП МО РФ на предприятия военно-промышленного комплекса России , а также работаем в рамках 275 ФЗ с открытием отдельных счетов в уполномоченном банке. Система менеджмента качества компании соответствует требованиям ГОСТ ISO 9001.

Минимальные сроки поставки, гибкие цены, неограниченный ассортимент и индивидуальный подход к клиентам являются основой для выстраивания долгосрочного и эффективного сотрудничества с предприятиями радиоэлектронной промышленности, предприятиями ВПК и научно-исследовательскими институтами России.

С нами вы становитесь еще успешнее!

Наши контакты:

Телефон: +7 812 627 14 35

Электронная почта: sales@st-electron.ru

Адрес: 198099, Санкт-Петербург,
Промышленная ул, дом № 19, литера Н,
помещение 100-Н Офис 331