

BROADCAST MECHANICAL TUNING AM/FM/SW RADIO RECEIVER

Features

- Worldwide FM band support (64–109 MHz)
 - Worldwide AM band support (504–1750 kHz)
 - SW band support (2.3–28.5 MHz)
 - No manual alignment necessary
 - Mono audio output
 - Selectable support AM/FM/SW regional bands
 - Enhanced FM/SW band coverage
 - Automatic frequency control (AFC)
 - Integrated LDO regulator
 - 2.0 to 3.6 V supply voltage
 - Wide range of ferrite loop sticks and air loop antennas supported
 - 16-pin SOIC
 - RoHS-compliant
 - Direct volume control
 - Not EN55020 compliant*
- ***Note:** For consumer applications that require EN 55020 compliance, use Si483x.

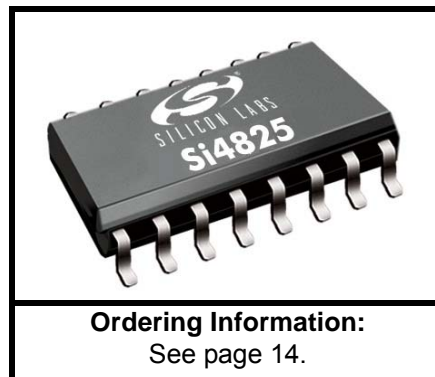

Applications

- Table and portable radios
- Mini/micro systems
- CD/DVD players
- Boom boxes
- Modules
- Clock radios
- Mini HiFi
- Entertainment systems

Description

The Si4825 is the entry level mechanical-tuned digital CMOS AM/FM/SW radio receiver IC that integrates the complete receiver function from antenna input to audio output. The Si4825 extends Silicon Laboratories multi-band tuner family, and further increases the ease and attractiveness of design radio reception to audio devices through small size and board area, minimum component count, and superior, proven performance. The Si4825 requires a simple application circuit and removes any requirements for manually tuning components during the manufacturing process. The receiver has very low power consumption, runs off two AAA batteries, and delivers the performance benefits of digital tuning to the analog radio market.

Functional Block Diagram

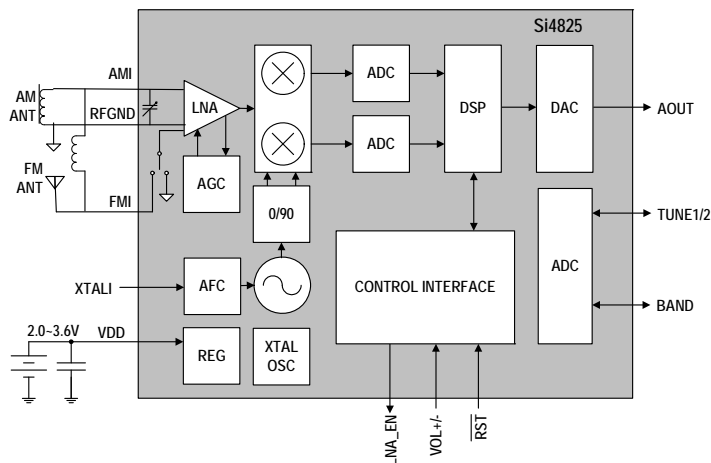

Pin Assignments

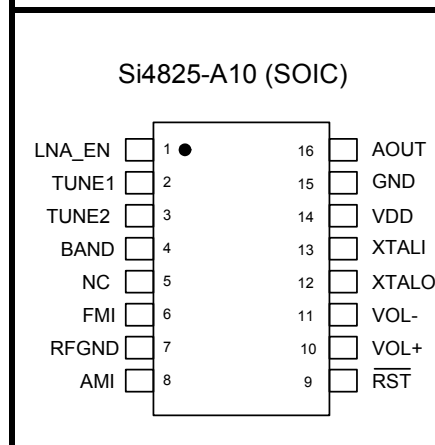

This product, its features, and/or its architecture is covered by one or more of the following patents, as well as other patents, pending and issued, both foreign and domestic: 7,127,217; 7,272,373; 7,272,375; 7,321,324; 7,355,476; 7,426,376; 7,471,940; 7,339,503; 7,339,504.

TABLE OF CONTENTS

<u>Section</u>	<u>Page</u>
1. Electrical Specifications	4
2. Typical Application Schematic	9
3. Bill of Materials	10
4. Functional Description	11
4.1. Overview	11
4.2. FM Receiver	11
4.3. AM Receiver	12
4.4. SW Receiver	12
4.5. Frequency Tuning	12
4.6. Band Select	12
4.7. Volume Control	12
4.8. Reset, Powerup, and Powerdown	12
5. Pin Descriptions: Si4825-A10	13
6. Ordering Guide	14
7. Package Outline: Si4825-A10	15
8. PCB Land Pattern: Si4825-A10	17
9. Top Marking	18
9.1. Si4825-A10 Top Marking	18
9.2. Top Marking Explanation	18
10. Additional Reference Resources	19
Document Change List	20
Contact Information	21

Si4825-A10

1. Electrical Specifications

Table 1. Recommended Operating Conditions^{1,2}

Parameter	Symbol	Test Condition	Min	Typ	Max	Unit
Supply Voltage ³	V_{DD}		2	—	3.6	V
Power Supply Powerup Rise Time	V_{DDRISE}		10	—	—	μ s
Ambient Temperature Range	T_A		0	25	70	$^{\circ}$ C

Note:

1. Typical values in the data sheet apply at $V_{DD} = 3.3$ V and 25° C unless otherwise stated.
2. All minimum and maximum specifications in the data sheet apply across the recommended operating conditions for minimum $V_{DD} = 2.7$ V.
3. Operation at minimum V_{DD} is guaranteed by characterization when V_{DD} voltage is ramped down to 2.0 V. Part initialization may become unresponsive below 2.3 V.

Table 2. DC Characteristics

($V_{DD} = 2.7$ to 3.6 V, $T_A = 0$ to 70° C)

Parameter	Symbol	Test Condition	Min	Typ	Max	Unit
FM Mode						
Supply Current*	I_{FM}		—	20.0	—	mA
AM/SW Mode						
Supply Current*	I_{AM}		—	19.0	—	mA
Supplies and Interface						
V_{DD} Powerdown Current	I_{DDPD}		—	10	—	μ A

***Note:** Specifications are guaranteed by characterization.

Table 3. Reset Timing Characteristics $(V_{DD} = 2.7 \text{ to } 3.6 \text{ V}, T_A = 0 \text{ to } 70 \text{ }^\circ\text{C})$

Parameter	Symbol	Min	Typ	Max	Unit
RSTB Pulse Width	t_{PRST}	100	—	—	μs
VDD valid time before RSTB rises	t_{SRST}	100	—	—	μs
RSTB low time before VDD becomes invalid	t_{RRST}	0	—	—	μs

Notes:

1. RSTB must be held low for at least 100 μs after the voltage supply has been ramped up.
2. RSTB needs to be asserted (pulled low) prior to the supply voltage being ramped down.

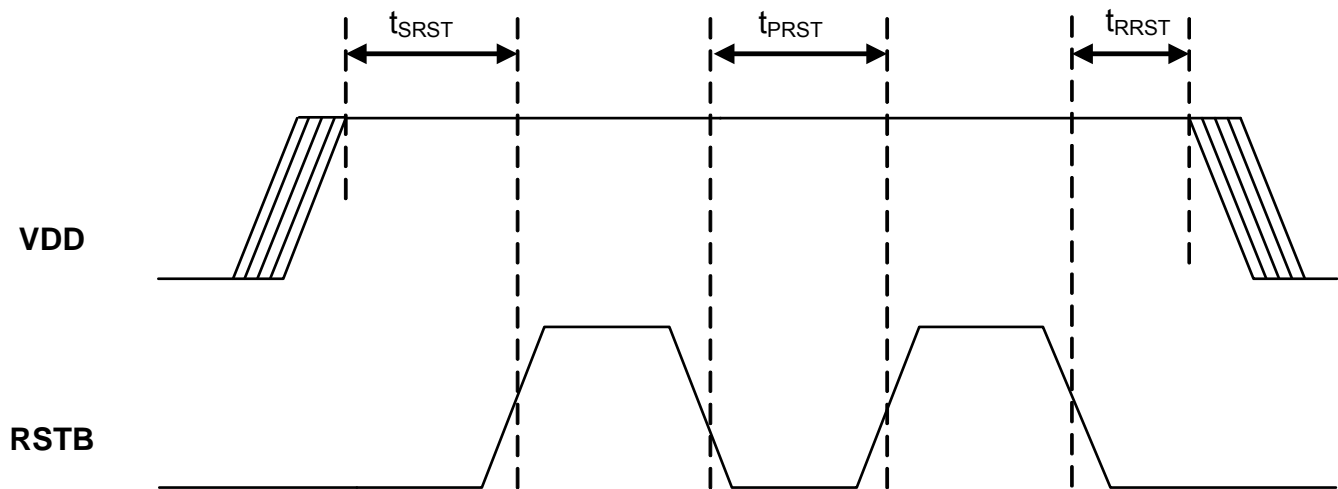
**Figure 1. Reset Timing**

Si4825-A10

Table 4. FM Receiver Characteristics^{1,2}

(V_{DD} = 2.7 to 3.6 V, TA = 0 to 70 °C)

Parameter	Symbol	Test Condition	Min	Typ	Max	Unit
Input Frequency	f _{RF}		64	—	109	MHz
Sensitivity with Headphone Network ³		(S+N)/N = 26 dB	—	4.0	—	μV EMF
LNA Input Resistance ^{4,5}			—	4	—	kΩ
LNA Input Capacitance ^{4,5}			—	5	—	pF
AM Suppression ^{4,5,6,7}		m = 0.3	—	50	—	dB
Input IP ₃ ^{4,8}			—	105	—	dBμV EMF
Adjacent Channel Selectivity ⁴		±200 kHz	—	45	—	dB
Alternate Channel Selectivity ⁴		±400 kHz	—	60	—	dB
Audio Output Voltage ^{5,6,7}			—	72	—	mV _{RMS}
Audio Mono S/N ^{5,6,7,9,10}			—	45	—	dB
Audio Frequency Response Low ⁴		-3 dB	—	—	30	Hz
Audio Frequency Response High ⁴		-3 dB	15	—	—	kHz
Audio THD ^{6,5,11}			—	0.1	0.5	%
Audio Output Load Resistance ^{4,10}	R _L	Single-ended	10	—	—	kΩ
Audio Output Load Capacitance ^{4,10}	C _L	Single-ended	—	—	50	pF

Notes:

1. Additional testing information is available in “AN569: Si4831/35/36/20/24/25-DEMO Board Test Procedure.” Volume = maximum for all tests. Tested at RF = 98.1 MHz.
2. To ensure proper operation and receiver performance, follow the guidelines in “AN738: Si4825/36-A Antenna, Schematic, Layout, and Design Guidelines.” Silicon Laboratories will evaluate schematics and layouts for qualified customers.
3. Frequency is 64~109 MHz.
4. Guaranteed by characterization.
5. V_{EMF} = 1 mV.
6. F_{MOD} = 1 kHz, MONO, and L = R unless noted otherwise.
7. Δf = 22.5 kHz.
8. |f₂ - f₁| > 2 MHz, f₀ = 2 x f₁ - f₂.
9. B_{AF} = 300 Hz to 15 kHz, A-weighted.
10. At A_{OUT} pin.
11. Δf = 75 kHz.

Table 5. AM/SW Receiver Characteristics^{1, 2}(V_{DD} = 2.7 to 3.6 V, TA = 0 to 70 °C)

Parameter	Symbol	Test Condition	Min	Typ	Max	Unit
Input Frequency	f _{RF}	Medium Wave (AM)	504	—	1750	kHz
		Short Wave (SW)	2.3	—	28.5	MHz
Sensitivity ^{3,4,5}		(S+N)/N = 26 dB	—	30	—	μV EMF
Large Signal Voltage Handling ⁵		THD < 8%	—	300	—	mV _{RMS}
Power Supply Rejection Ratio ⁵		ΔV _{DD} = 100 mV _{RMS} , 100 Hz	—	40	—	dB
Audio Output Voltage ^{3,6}			—	54	—	mV _{RMS}
Audio S/N ^{3,4,6}			—	45	—	dB
Audio THD ^{3,6}			—	0.1	—	%
Antenna Inductance ^{5,7}			180	—	450	μH

Notes:

1. Additional testing information is available in “AN569: Si4831/35/36/20/24/25-DEMO Board Test Procedure.” Volume = maximum for all tests. Tested at RF = 6 MHz.
2. To ensure proper operation and receiver performance, follow the guidelines in “AN738: Si4825/36-A Antenna, Schematic, Layout, and Design Guidelines.” Silicon Laboratories will evaluate schematics and layouts for qualified customers.
3. F_{MOD} = 1 kHz, 30% modulation, 2 kHz channel filter.
4. B_{AF} = 300 Hz to 15 kHz, A-weighted.
5. Guaranteed by characterization.
6. V_{IN} = 5 mV_{rms}.
7. Stray capacitance on antenna and board must be < 10 pF to achieve full tuning range at higher inductance levels.

Table 6. Reference Clock and Crystal Characteristics(V_{DD} = 2.7 to 3.6 V, T_A = 0 to 70 °C)

Parameter	Symbol	Test Condition	Min	Typ	Max	Unit
Reference Clock						
XTALI Supported Reference Clock Frequencies			—	32.768	—	kHz
Reference Clock Frequency Tolerance for XTALI			-100	—	100	ppm
Crystal Oscillator						
Crystal Oscillator Frequency			—	32.768	—	kHz
Crystal Frequency Tolerance			-100	—	100	ppm
Board Capacitance			—	—	3.5	pF

Table 7. Thermal Conditions

Parameter	Symbol	Min	Typ	Max	Unit
Thermal Resistance*	θ_{JA}	—	80	—	°C/W
Ambient Temperature	T_A	0	25	70	°C
Junction Temperature	T_J	—	—	77	°C

***Note:** Thermal resistance assumes a multi-layer PCB with the exposed pad soldered to a topside PCB pad.

Table 8. Absolute Maximum Ratings^{1,2}

Parameter	Symbol	Value	Unit
Supply Voltage	V_{DD}	-0.5 to 5.8	V
Input Current ³	I_{IN}	10	mA
Operating Temperature	T_{OP}	-40 to 95	°C
Storage Temperature	T_{STG}	-55 to 150	°C
RF Input Level ⁴		0.4	V_{PK}

Notes:

1. Permanent device damage may occur if the above Absolute Maximum Ratings are exceeded. Functional operation should be restricted to the conditions as specified in the operational sections of this data sheet. Exposure beyond recommended operating conditions for extended periods may affect device reliability.
2. The Si4825 devices are high-performance RF integrated circuits with certain pins having an ESD rating of < 2 kV HBM. Handling and assembly of these devices should only be done at ESD-protected workstations.
3. For input pins RST, VOL+, VOL-, XTALO, XTALI, BAND, TUNE2, TUNE1, LNA_EN.
4. At RF input pins, FMI and AMI.

2. Typical Application Schematic

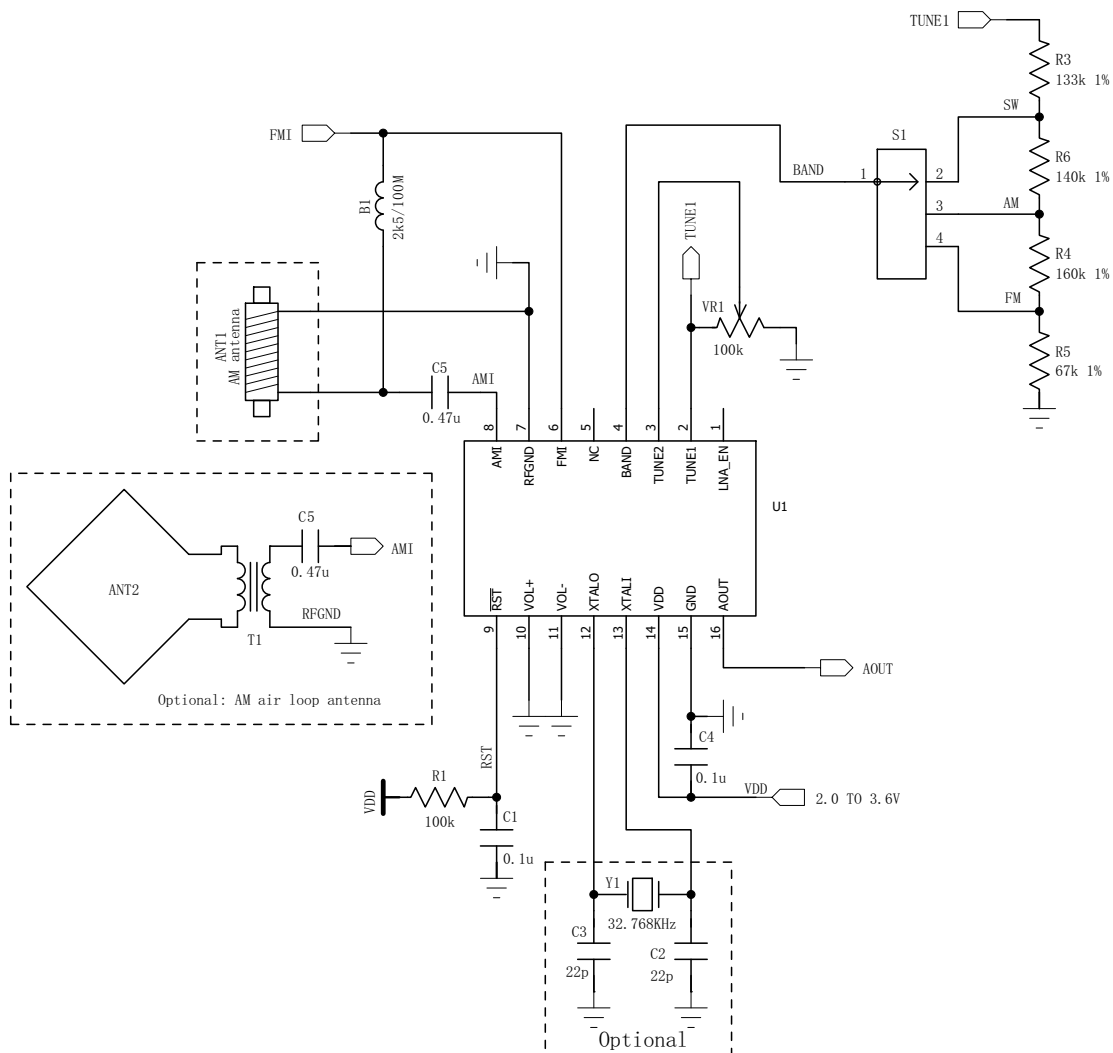

Notes:

1. Place C_4 close to V_{DD} and GND pins.
2. Pin 15 GND connects directly to GND plane on PCB.
3. Pin 5 leave floating.
4. To ensure proper operation and receiver performance, follow the guidelines in "AN738: Si4825/36-A Antenna, Schematic, Layout, and Design Guidelines." Silicon Labs will evaluate the schematics and layouts for qualified customers.
5. Pin 6 connects to the FM antenna interface and pin 8 connects to the AM antenna interface.
6. Place Si4825 as close as possible to antenna jack and keep the FMI and AMI traces as short as possible.
7. Recommend keeping the AM ferrite loop antenna at least 5 cm away from the tuner chip.
8. Keep the AM ferrite loop antenna at least 5 cm away from MCU, audio AMP, and other circuits which have AM interference.
9. Place the transformer T1 away from any sources of interference and even away from the I/O signals of the Si4825.

Si4825-A10

3. Bill of Materials

Table 9. Si4825-A Bill of Materials

Component(s)	Value/Description	Supplier
C1	Reset capacitor 0.1 μ F, \pm 20%, Z5U/X7R	Murata
C4	Supply bypass capacitor, 0.1 μ F, \pm 20%, Z5U/X7R	Murata
C5	Coupling capacitor, 0.47 μ F, \pm 20%, Z5U/X7R	Venkel
B1	Ferrite bead 2.5 k/100 MHz	Murata
VR1	Variable resistor (POT), 100 k Ω , \pm 10%	Kennon
R1	Reset timing resistor, 100 k Ω , \pm 5%	Venkel
R3	Resistor, 133 k Ω , \pm 1%,	Venkel
R4	Resistor, 160 k Ω , \pm 1%	Venkel
R5	Resistor, 67 k Ω , \pm 1%	Venkel
R6	Resistor, 140 k Ω , \pm 1%	Venkel
U1	Si4825-A AM/FM/SW Analog Tune Analog Display Radio Tuner	Silicon Laboratories
S1	Band switch	Any, depends on customer
ANT1	Ferrite stick, 180-450 μ H	Jiaxin
Optional Components		
C2, C3	Crystal load capacitors, 22 pF, \pm 5%, COG (Optional: for crystal oscillator option)	Venkel
Y1	32.768 kHz crystal (Optional: for crystal oscillator option)	Epson or equivalent
ANT2	Air loop antenna, 10–20 μ H	Various

4. Functional Description

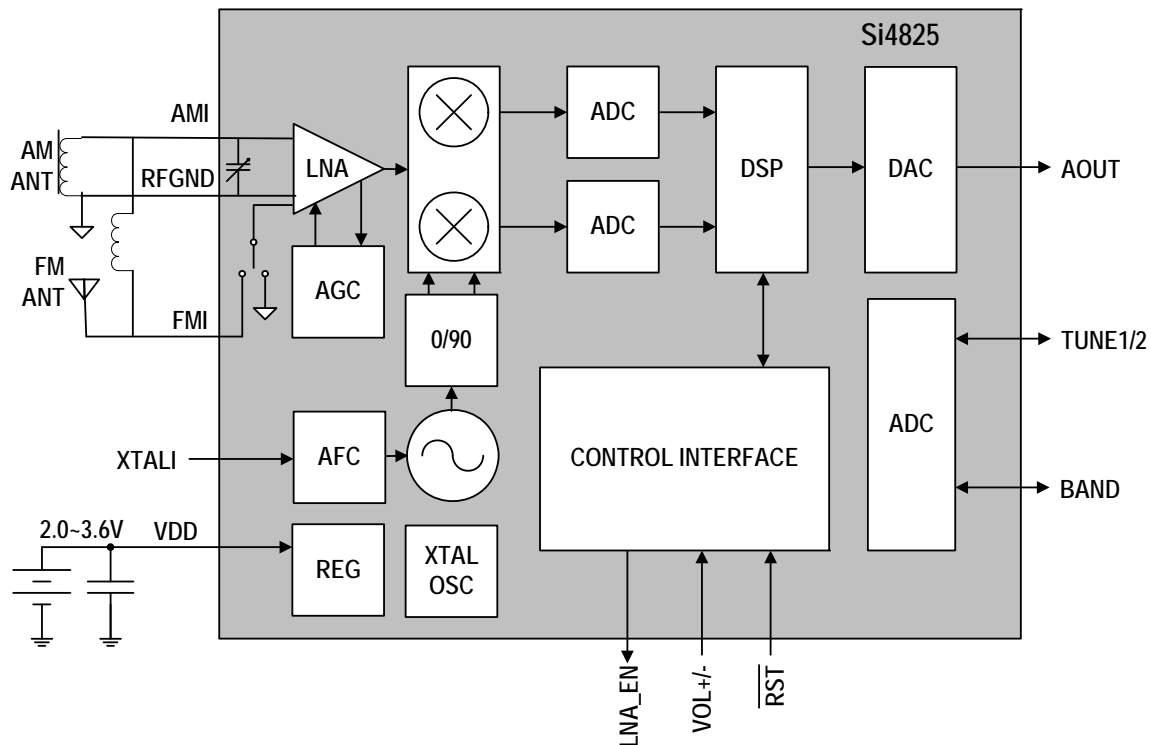

Figure 2. Si4825 Functional Block Diagram

4.1. Overview

The Si4825 is the entry level mechanical-tuned digital CMOS AM/FM/SW radio receiver IC that integrates the complete receiver function from antenna input to audio output. The Si4825 extends Silicon Laboratories multi-band tuner family, and further increases the ease and attractiveness of design radio reception to audio devices through small size and board area, minimum component count, and superior, proven performance. The Si4825 requires a simple application circuit, and removes any requirements for manually tuning components during the manufacturing process.

Leveraging Silicon Laboratories' proven and patented digital low intermediate frequency (low-IF) receiver architecture, the Si4825 delivers desired RF performance and interference rejection in AM, FM, and SW bands. The high integration and complete system production test simplifies design-in, increases system quality, and improves manufacturability.

4.2. FM Receiver

The Si4825 integrates a low noise amplifier (LNA) supporting the worldwide FM broadcast band (64 to 109 MHz) and the TV audio stations within the frequency range in China area are also supported.

Pre-emphasis and de-emphasis is a technique used by FM broadcasters to improve the signal-to-noise ratio of FM receivers by reducing the effects of high frequency interference and noise. When the FM signal is transmitted, a pre-emphasis filter is applied to accentuate the high audio frequencies. All FM receivers incorporate a de-emphasis filter which attenuates high frequencies to restore a flat frequency response. Two time constants are used in various regions. The de-emphasis time constant can be chosen to be 50 or 75 μ s.

4.3. AM Receiver

The highly integrated Si4825-A10 supports worldwide AM band reception from 504 to 1750 kHz with five sub-bands using a digital low-IF architecture with a minimum number of external components and no manual alignment required. This patented architecture allows for high-precision filtering, offering excellent selectivity and SNR with minimum variation across the AM band. The Si4825 supports the worldwide AM band with five sub-bands. One of the bands is a universal AM band (AM4, 520–1730 kHz) supporting both 9 kHz and 10 kHz channel spaces for all regional AM standards of the world. Similar to the FM receiver, the Si4825-A10 optimizes sensitivity and rejection of strong interferers, allowing better reception of weak stations.

To offer maximum flexibility, the receiver supports a wide range of ferrite loop sticks from 180–450 μ H. An air loop antenna is supported by using a transformer to increase the effective inductance from the air loop. Using a 1:5 turn ratio inductor, the inductance is increased by 25 times and easily supports all typical AM air loop antennas, which generally vary between 10 and 20 μ H.

4.4. SW Receiver

The Si4825 supports 36 short wave (SW) band receptions from 2.3 to 28.5 MHz, 18 of which are meter wave band (Narrow), and the rest of the SW bands are with wider frequency range that can be used in SW radio with 1 or 2 SW bands. Si4825 supports extensive short wave features such as minimal discrete components and no factory adjustments. The Si4825 supports using the FM antenna to capture short wave signals.

4.5. Frequency Tuning

A valid channel can be found by tuning the potentiometer that is connected to the TUNE1 and TUNE2 pin of the Si4825-A10 chip.

4.6. Band Select

The Si4825-A10 supports worldwide AM band with five sub-bands, US/Europe/Japan/China FM band with five sub-bands, and SW band with 36 sub-bands. For details on band selection, refer to "AN738: Si4825/36-A Antenna, Schematic, Layout, and Design Guidelines."

4.7. Volume Control

The Si4825 not only allows customers to use the traditional PVR wheel volume control through an external speaker amplifier, it also supports direct digital volume control through pins 10 and pin 11 by using volume up and down buttons. Refer to "AN738: Si4825/36-A Antenna, Schematic, Layout, and Design Guidelines."

4.8. Reset, Powerup, and Powerdown

Setting the RSTB pin low will disable analog and digital circuitry, reset the registers to their default settings, and disable the bus. Setting the RSTB pin high will bring the device out of reset.

Figure 1 shows typical reset, startup, and shutdown timings for the Si4825. RSTB must be held low (asserted) during any power supply transitions and kept asserted as specified in Figure 1 after the power supplies are ramped up and stable. Failure to assert RSTB as indicated here may cause the device to malfunction and may result in permanent device damage.

A powerdown mode is available to reduce power consumption when the part is idle. Putting the device in powerdown mode will disable analog and digital circuitry while keeping the bus active.

5. Pin Descriptions: Si4825-A10

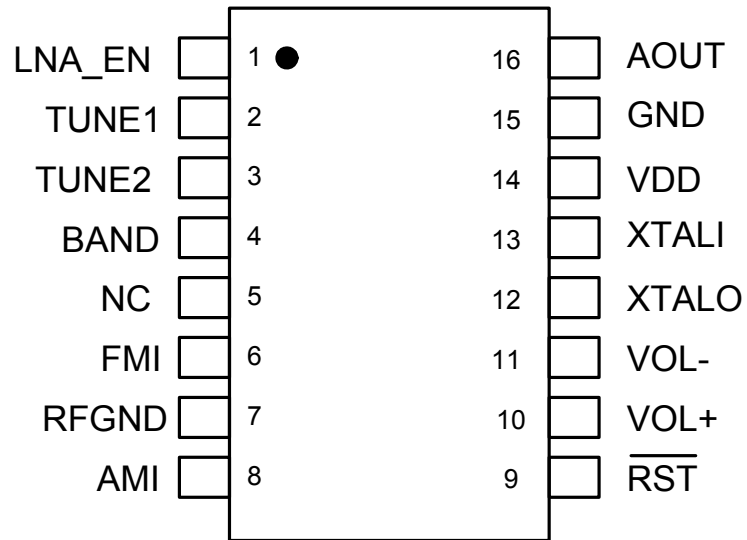

Pin Number(s)	Name	Description
1	LNA_EN	Enable SW external LNA.
2	TUNE1	Frequency tuning
3	TUNE2	Frequency tuning
4	BAND	Band selection and de-emphasis selection
5	NC	No connect. Leave floating.
6	FMI	FM RF inputs. FMI should be connected to the antenna trace.
7	RFGND	RF ground. Connect to ground plane on PCB.
8	AMI	AM RF input. AMI should be connected to the AM antenna.
9	$\overline{\text{RST}}$	Device reset (active low) input
10	VOL+	Volume button up
11	VOL-	Volume button down
12	XTALO	Crystal oscillator output
13	XTALI	Crystal oscillator input/external reference clock input
14	VDD	Supply voltage. May be connected directly to battery.
15	GND	Ground. Connect to ground plane on PCB.
16	AOUT	Audio output

Si4825-A10

6. Ordering Guide

Part Number ^{1,2}	Description	Package Type	Operating Temperature/Voltage
Si4825-A10-CS	AM/FM/SW Broadcast Radio Receiver	16L SOIC Pb-free	0 to 70 °C 2.0 to 3.6 V

Notes:

1. Add an "(R)" at the end of the device part number to denote tape and reel option. The devices will typically operate at 25 °C with degraded specifications for V_{DD} voltage ramped down to 2.0 V.
2. The -C suffix in the part number indicates Consumer Grade product. Please visit www.silabs.com to get more information on product grade specifications.

7. Package Outline: Si4825-A10

The 16-pin SOIC illustrates the package details for the Si4825-A10. Table 10 lists the values for the dimensions shown in the illustration.

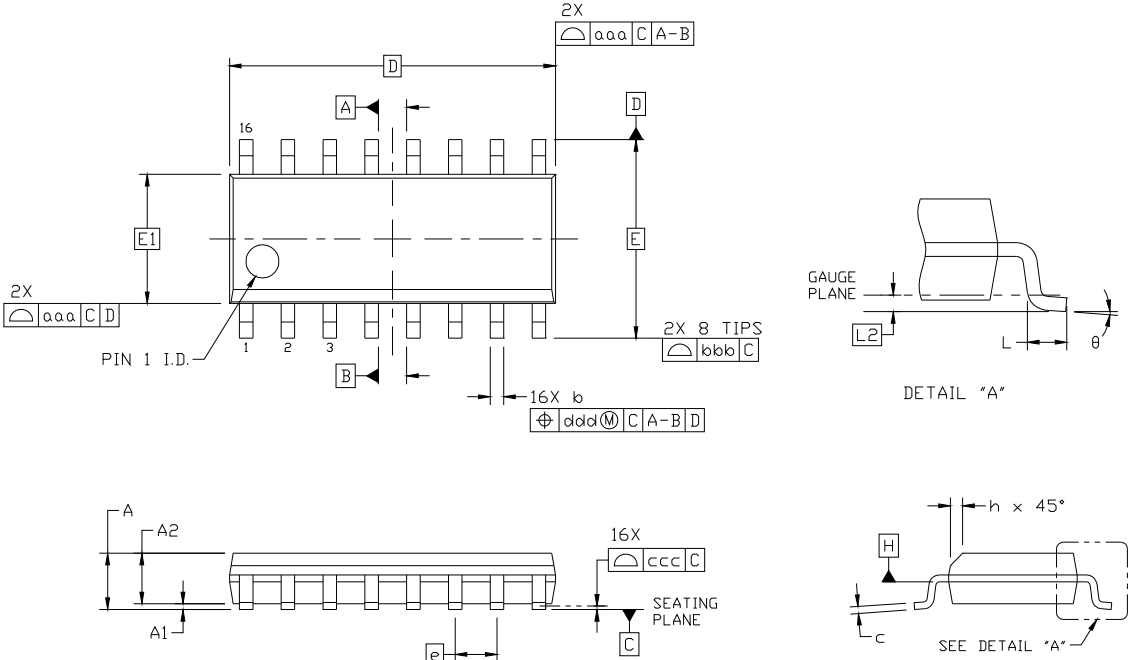

Figure 3. 16-Pin SOIC

Table 10. Package Dimensions

Dimension	Min	Max
A	—	1.75
A1	0.10	0.25
A2	1.25	—
b	0.31	0.51
c	0.17	0.25
D	9.90 BSC	
E	6.00 BSC	
E1	3.90 BSC	
e	1.27 BSC	
L	0.40	1.27
L2	0.25 BSC	
h	0.25	0.50
θ	0°	8°
aaa	0.10	
bbb	0.20	
ccc	0.10	
ddd	0.25	
Notes:		
<ol style="list-style-type: none">1. All dimensions shown are in millimeters (mm) unless otherwise noted.2. Dimensioning and Tolerancing per ANSI Y14.5M-1994.3. This drawing conforms to the JEDEC Solid State Outline MS-012, Variation AC.4. Recommended card reflow profile is per the JEDEC/IPC J-STD-020 specification for Small Body Components.		

8. PCB Land Pattern: Si4825-A10

Figure 4, "PCB Land Pattern," illustrates the PCB land pattern details for the Si4825-A10-CS SOIC. Table 11 lists the values for the dimensions shown in the illustration.

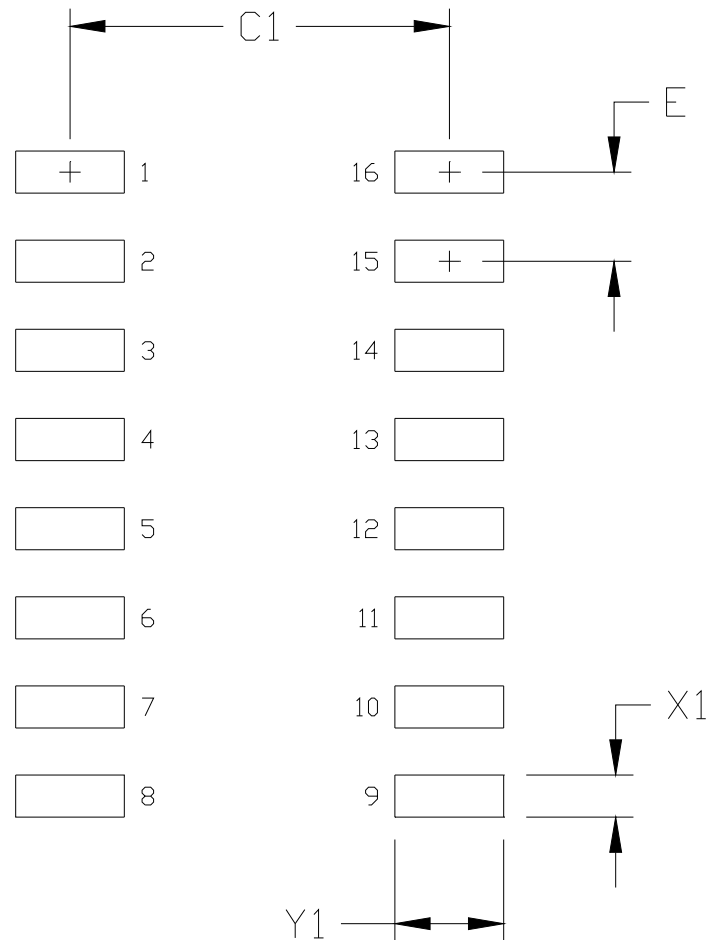

Figure 4. PCB Land Pattern

Table 11. PCB Land Pattern Dimensions

Dimension	Feature	(mm)
C1	Pad Column Spacing	5.40
E	Pad Row Pitch	1.27
X1	Pad Width	0.60
Y1	Pad Length	1.55

Notes:

1. This Land Pattern Design is based on IPC-7351 pattern SOIC127P600X165-16N for Density Level B (Median Land Protrusion).
2. All feature sizes shown are at Maximum Material Condition (MMC) and a card fabrication tolerance of 0.05 mm is assumed.

Si4825-A10

9. Top Marking

9.1. Si4825-A10 Top Marking

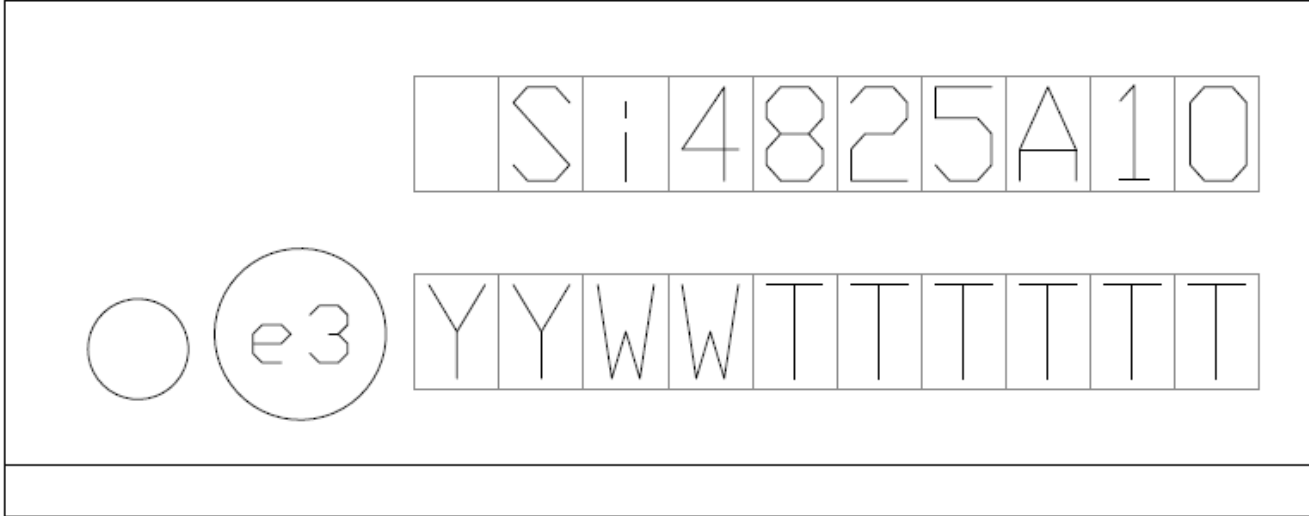

9.2. Top Marking Explanation

Mark Method:	Laser	
Pin 1 Mark:	Mold Dimple (Bottom-Left Corner)	
Font Size:	0.71 mm (2.0 Point) Right-Justified	
Line 1 Mark Format:	Custom Part Number	Si4825A10
Line 2 Mark Format:	Circle = 1.3 mm Diameter	“e3” Pb-Free Symbol
	YY = Year WW = Work week	Assigned by the Assembly House. Corresponds to the year and work week of the mold date.
	TTTTTT = Manufacturing code	Manufacturing Code from the Assembly Purchase Order form.

10. Additional Reference Resources

Contact your local sales representatives for more information or to obtain copies of the following references:

- AN738: Si4825/36-A Antenna, Schematic, Layout, and Design Guidelines
- AN569: Si4831/35/36/20/24/25-DEMO Board Test Procedure
- Si4825-DEMO Board User's Guide

DOCUMENT CHANGE LIST

Revision 0.1 to Revision 0.8

- Updated Table 1, "Recommended Operating Conditions"
- Updated Table 2, "DC Characteristics"
- Updated Table 4, "FM Receiver Characteristics"
- Updated Table 5, "AM/SW Receiver Characteristics"
- Updated Section "4.3. AM Receiver"
- Updated Section "10. Additional Reference Resources"
- Section 5 "Pin Descriptions: Si4825-A10"

Revision 0.8 to Revision 1.0

- Updated Table 3. "Reset Timing Characteristics"
- Inserted Section 4.8. "Reset, Powerup, and Powerdown"

CONTACT INFORMATION

Silicon Laboratories Inc.

400 West Cesar Chavez
Austin, TX 78701
Tel: 1+(512) 416-8500
Fax: 1+(512) 416-9669
Toll Free: 1+(877) 444-3032
Email: FMinfo@silabs.com
Internet: www.silabs.com

Patent Notice

Silicon Labs invests in research and development to help our customers differentiate in the market with innovative low-power, small size, analog-intensive mixed-signal solutions. Silicon Labs' extensive patent portfolio is a testament to our unique approach and world-class engineering team.

The information in this document is believed to be accurate in all respects at the time of publication but is subject to change without notice. Silicon Laboratories assumes no responsibility for errors and omissions, and disclaims responsibility for any consequences resulting from the use of information included herein. Additionally, Silicon Laboratories assumes no responsibility for the functioning of undescribed features or parameters. Silicon Laboratories reserves the right to make changes without further notice. Silicon Laboratories makes no warranty, representation or guarantee regarding the suitability of its products for any particular purpose, nor does Silicon Laboratories assume any liability arising out of the application or use of any product or circuit, and specifically disclaims any and all liability, including without limitation consequential or incidental damages. Silicon Laboratories products are not designed, intended, or authorized for use in applications intended to support or sustain life, or for any other application in which the failure of the Silicon Laboratories product could create a situation where personal injury or death may occur. Should Buyer purchase or use Silicon Laboratories products for any such unintended or unauthorized application, Buyer shall indemnify and hold Silicon Laboratories harmless against all claims and damages.

Silicon Laboratories and Silicon Labs are trademarks of Silicon Laboratories Inc.
Other products or brandnames mentioned herein are trademarks or registered trademarks of their respective holders.



Стандарт Электрон Связь

Мы молодая и активно развивающаяся компания в области поставок электронных компонентов. Мы поставляем электронные компоненты отечественного и импортного производства напрямую от производителей и с крупнейших складов мира.

Благодаря сотрудничеству с мировыми поставщиками мы осуществляем комплексные и плановые поставки широчайшего спектра электронных компонентов.

Собственная эффективная логистика и склад в обеспечивает надежную поставку продукции в точно указанные сроки по всей России.

Мы осуществляем техническую поддержку нашим клиентам и предпродажную проверку качества продукции. На все поставляемые продукты мы предоставляем гарантию .

Осуществляем поставки продукции под контролем ВП МО РФ на предприятия военно-промышленного комплекса России , а также работаем в рамках 275 ФЗ с открытием отдельных счетов в уполномоченном банке. Система менеджмента качества компании соответствует требованиям ГОСТ ISO 9001.

Минимальные сроки поставки, гибкие цены, неограниченный ассортимент и индивидуальный подход к клиентам являются основой для выстраивания долгосрочного и эффективного сотрудничества с предприятиями радиоэлектронной промышленности, предприятиями ВПК и научно-исследовательскими институтами России.

С нами вы становитесь еще успешнее!

Наши контакты:

Телефон: +7 812 627 14 35

Электронная почта: sales@st-electron.ru

Адрес: 198099, Санкт-Петербург,
Промышленная ул, дом № 19, литера Н,
помещение 100-Н Офис 331