

ADSP-CM403F EZ-KIT Lite® Evaluation System Manual

Revision 1.0, September 2013

Part Number
82-000342-01

Analog Devices, Inc.
One Technology Way
Norwood, Mass. 02062-9106



Copyright Information

©2013 Analog Devices, Inc., ALL RIGHTS RESERVED. This document may not be reproduced in any form without prior, express written consent from Analog Devices, Inc.

Printed in the USA.

Disclaimer

Analog Devices, Inc. reserves the right to change this product without prior notice. Information furnished by Analog Devices is believed to be accurate and reliable. However, no responsibility is assumed by Analog Devices for its use; nor for any infringement of patents or other rights of third parties which may result from its use. No license is granted by implication or otherwise under the patent rights of Analog Devices, Inc.

Trademark and Service Mark Notice

The Analog Devices logo, EngineerZone, EZ-Board, and EZ-KIT Lite are registered trademarks of Analog Devices, Inc.

All other brand and product names are trademarks or service marks of their respective owners.

Regulatory Compliance

The ADSP-CM403F EZ-KIT Lite is designed to be used solely in a laboratory environment. The board is not intended for use as a consumer end product or as a portion of a consumer end product. The board is an open system design which does not include a shielded enclosure and therefore may cause interference to other electrical devices in close proximity. This board should not be used in or near any medical equipment or RF devices.

The ADSP-CM403F EZ-KIT Lite is in the process of being certified to comply with the essential requirements of the European EMC directive 2004/108/EC and therefore carries the “CE” mark.



The EZ-KIT Lite evaluation system contains ESD (electrostatic discharge) sensitive devices. Electrostatic charges readily accumulate on the human body and equipment and can discharge without detection. Permanent damage may occur on devices subjected to high-energy discharges. Proper ESD precautions are recommended to avoid performance degradation or loss of functionality. Store unused EZ-KIT Lite boards in the protective shipping package.



CONTENTS

PREFACE

Product Overview	x
Purpose of This Manual	xiii
Intended Audience	xiv
Manual Contents	xv
What's New in This Manual	xv
Technical Support	xvi
Supported Processors	xvi
Supported Tools	xvii
Product Information	xvii
Analog Devices Web Site	xvii
EngineerZone	xviii
Notation Conventions	xviii

Contents

USING ADSP-CM403F EZ-KIT LITE

Package Contents	1-2
ADSP-CM403F EZ-Board	1-3
Default Configuration	1-3
IAR Embedded WorkBench and Board Installation	1-5
IAR Embedded WorkBench Session Startup	1-6
SPI Flash	1-8
Analog Interface	1-8
UART0 Interface (RS-232)	1-9
CAN0 Interface	1-10
Debug Interface	1-10
Serial Liquid Crystal Display Module Interface	1-10
Power-On-Self Test	1-11
Expansion Interface	1-11
Power Architecture	1-12
Power Measurements	1-12
Example Programs	1-13
Reference Design Information	1-13

ADSP-CM403F EZ-KIT LITE HARDWARE REFERENCE

System Architecture	2-2
Software-Controlled Switches (SoftConfig)	2-3
Overview of SoftConfig	2-3
SoftConfig on the ADSP-CM403F EZ-KIT LITE	2-7
Programming SoftConfig Switches	2-8
Push Buttons and Switches	2-12
Boot Mode Select Switch (SW1)	2-13
Reset Push Button (SW2)	2-13
GPIO Push Buttons (SW3-4)	2-13
Jumpers	2-14
VREF0 External Source Jumper (JP1)	2-15
VREF1 External Source Jumper (JP2)	2-15
Buffer Input Select Jumper (JP3)	2-15
Power Select Jumper (JP4)	2-16
Power Jumpers (P4–6)	2-16
LEDs	2-17
GPIO LEDs (LED1–3)	2-18
Reset LED (LED4)	2-18
Power LED (LED5)	2-18
SYS_FAULT LED (LED6)	2-18

Contents

Connectors	2-19
DCE UART Connector (J1)	2-20
Asynch or Memory Connector (J2)	2-20
Character Display Connector (J3)	2-20
PWM Connector (J7)	2-21
CAN0 Connector (J8)	2-21
Analog Connector (J9)	2-21
JTAG/SWD/SWV Connector (P1)	2-21
TRACE and JTAG/SWD/SWV Connector (P2)	2-22
VREF Buffered Connector (P3)	2-22
Power Connector (P7)	2-22

ADSP-CM403F EZ-KIT LITE BILL OF MATERIALS

ADSP-CM403F EZ-KIT LITE SCHEMATIC

INDEX

PREFACE

Thank you for purchasing the ADSP-CM403F EZ-KIT Lite[®], Analog Devices, Inc. low-cost evaluation system for the ADSP-CM403F mixed-signal control processor.

The ADSP-CM403F processor is based on the ARM[®] Cortex[®]-M4 processor core and is designed for photovoltaic applications. The EZ-KIT Lite is shipped with all of the necessary hardware—you can start the evaluation immediately. The package contains the standalone evaluation board and CE-approved power supply. The EZ-KIT Lite version ships with the J-Link Lite ARM, while the EZ-Board[®] version requires the customer to provide a debugger.

Two expansion connectors (analog interface and PWM/digital interface) are provided for connecting boards that incorporate motors. Another expansion connector is provided for connecting an Anybus board and/or a memory/FPGA extender card.

Traditional mechanical switches for changing the board's factory setup have been removed in favor of I²C controlled software switches. The only remaining mechanical switches are the boot mode switch and push buttons.

Product Overview

The evaluation board is designed to be used in conjunction with the IAR Embedded Workbench development tools to test capabilities of the ADSP-CM403F processors. The development environment aids advanced application code development and debug, such as:

- Create, compile, assemble, and link application programs written in C++, C, and assembly
- Load, run, step, halt, and set breakpoints in application programs
- Read and write data and program memory
- Read and write core and peripheral registers

Product Overview

The board features:

- Analog Devices ADSP-CM403F processor
 - 120-pin LQFP package
 - 30 MHz CLKIN core oscillator
- Universal Asynchronous Receiver/Transmitter (UART0)
 - Analog Devices ADM3252E RS-232 line transceiver
 - DB9 female connector
- Controller Area Network (CAN) interface
 - Analog Devices ADM3053 transceiver
 - RJ11 connector

- Display
 - New Haven NHD-0220D3Z-FL-GBW
 - 2 × 20 character
 - 2-wire interface (TWI) control
- RESET controller
 - Analog Devices ADM708 microprocessor supervisory circuits
- Debug (JTAG/SWD/SWV/TRACE) interface
 - JTAG/SWD 20-pin 0.1" header for use with IAR emulators
 - Trace/JTAG/SWD/SWV 20-pin 0.05" header
- LEDs
 - Six LEDs: one power (green), one board reset (red), one SYS_FAULT (red), and three general-purpose (amber)
- Push buttons
 - Three push buttons: one reset, two IRQ/Flag
- Asynchronous connector
 - 180-pin Samtec (QSH-090-01-F-D-A) 0.5 mm spacing
 - SMC0 address, data, and control
 - CLKOUT
 - SPI0
 - UART2
 - TWI0
 - GPIOs

Product Overview

- RESET
- GND/3.3V/5V output
- Pulse-width modulation (PWM) connector
 - 180-pin Samtec (QSH-090-01-F-D-A) 0.5 mm spacing
 - PWM0–PWM2
 - SINC0
 - SPI0
 - TWI0
 - TM0
 - CNT0–CNT1
 - SPORT1
 - GPIO
 - RESET
 - GND/3.3V/5V output
 - 5V input
- Analog connector interface
 - 120-pin Samtec (QSH-060-01-F-D-A) 0.5 mm spacing
 - ADC0–ADC1
 - DAC0–1
 - AGND/GND/VREF/5V output
 - ADR441 voltage reference (VREF)
 - ADA4899 buffer—0.1” header for reference

- External power supply
 - CE compliant
 - 5V @ 3.6 Amps
 - Ability to power from the PWM connector
- Other features
 - 0.05-ohm resistors for processor current measurement

For information about the hardware components of the EZ-KIT Lite, refer to [ADSP-CM403F EZ-KIT Lite Bill Of Materials](#).

Purpose of This Manual

The *ADSP-CM403F EZ-KIT Lite Evaluation System Manual* provides instructions for installing the product hardware (board). The text describes operation and configuration of the board components and provides guidelines for running your own code on the ADSP-CM403F EZ-KIT Lite. Finally, a schematic and a bill of materials are provided for reference.

Intended Audience

The primary audience for this manual is a programmer who is familiar with an ARM Cortex-M4-based core.

The ADSP-CM40x family of mixed-signal control processors is based on the ARM Cortex-M4 processor core with floating-point unit and integrated SRAM memory, flash memory, accelerators, and peripherals.

The applicable documentation for programming the ARM Cortex-M4 processor core includes:

- *Cortex-M4 Devices Generic User Guide*
- *CoreSight ETM-M4 Technical Reference Manual*
- *Cortex-M4 Technical Reference Manual*

For additional information on this Analog Devices processor, see the *ADSP-CM40x Mixed-Signal Control Processor Hardware Reference*. This document describes the ARM Cortex-M4 processor core and memory architecture used on the ADSP-CM40x processor, but does not provide detailed programming information for the ARM core.

For more information about programming the ARM core, visit the ARM Information Center:

<http://infocenter.arm.com/help/>

Manual Contents

The manual consists of:

- Chapter 1, [Using ADSP-CM403F EZ-KIT Lite](#)
Describes EZ-KIT Lite functionality from a programmer's perspective and provides a simplified memory map of the processor.
- Chapter 2, [ADSP-CM403F EZ-KIT Lite Hardware Reference](#)
Provides information about the EZ-KIT Lite hardware components.
- Appendix A, [ADSP-CM403F EZ-KIT Lite Bill Of Materials](#)
Lists the hardware components used to manufacture the EZ-KIT Lite.
- Appendix B, [ADSP-CM403F EZ-KIT Lite Schematic](#)
Lists the resources for board-level debugging.

What's New in This Manual

This is the first edition (Revision 1.0) of the *ADSP-CM403F EZ-KIT Lite Evaluation System Manual*.

Technical Support

You can reach Analog Devices processors and DSP technical support in the following ways:

- Post your questions in the processors and DSP support community at EngineerZone®:
<http://ez.analog.com/community/dsp>
- Submit your questions to technical support directly at:
<http://www.analog.com/support>
- E-mail your questions about processors and processor applications to:
processor.support@analog.com or
processor.china@analog.com (Greater China support)
- In the **USA only**, call **1-800-ANALOGD** (1-800-262-5643)
- Contact your Analog Devices sales office or authorized distributor. Locate one at:
www.analog.com/adi-sales
- Send questions by mail to:
Processors and DSP Technical Support
Analog Devices, Inc.
Three Technology Way
P.O. Box 9106
Norwood, MA 02062-9106
USA

Supported Processors

This evaluation system supports Analog Devices ADSP-CM403F processors.

Supported Tools

Information on supported tools for the ADSP-CM403F EZ-KIT Lite and the ADSP-CM40x family of mixed-signal control processors is available at:

<http://www.analog.com/CM403FEZKit>

Product Information

Product information can be obtained from the Analog Devices Web site and the online help system.

Analog Devices Web Site

The Analog Devices Web site, www.analog.com, provides information about a broad range of products—analogue integrated circuits, amplifiers, converters, and digital signal processors.

To access a complete technical library for each processor family, go to http://www.analog.com/processors/technical_library. The manuals selection opens a list of current manuals related to the product as well as a link to the previous revisions of the manuals. When locating your manual title, note a possible errata check mark next to the title that leads to the current correction report against the manual.

Also note, myAnalog.com is a free feature of the Analog Devices Web site that allows customization of a Web page to display only the latest information about products you are interested in. You can choose to receive weekly e-mail notifications containing updates to the Web pages that meet your interests, including documentation errata against all manuals. myAnalog.com provides access to books, application notes, data sheets, code examples, and more.

Notation Conventions

Visit myAnalog.com (found on the Analog Devices home page) to sign up. If you are a registered user, just log on. Your user name is your e-mail address.

EngineerZone



EngineerZone is a technical support forum from Analog Devices. It allows you direct access to ADI technical support engineers. You can search FAQs and technical information to get quick answers to your embedded processing and DSP design questions.

Use EngineerZone to connect with other DSP developers who face similar design challenges. You can also use this open forum to share knowledge and collaborate with the ADI support team and your peers. Visit <http://ez.analog.com> to sign up.

Notation Conventions

Text conventions used in this manual are identified and described as follows.

Example	Description
File > Close	Titles in reference sections indicate the location of an item within the CCES environment's menu system (for example, the Close command appears on the File menu).
{this that}	Alternative required items in syntax descriptions appear within curly brackets and separated by vertical bars; read the example as <i>this</i> or <i>that</i> . One or the other is required.
[this that]	Optional items in syntax descriptions appear within brackets and separated by vertical bars; read the example as an optional <i>this</i> or <i>that</i> .
[this,...]	Optional item lists in syntax descriptions appear within brackets delimited by commas and terminated with an ellipsis; read the example as an optional comma-separated list of <i>this</i> .

Example	Description
.SECTION	Commands, directives, keywords, and feature names are in text with letter gothic font.
<i>filename</i>	Non-keyword placeholders appear in text with italic style format.
	<p>Note: For correct operation, ...</p> <p>A Note provides supplementary information on a related topic. In the online version of this book, the word Note appears instead of this symbol.</p>
	<p>Caution: Incorrect device operation may result if ...</p> <p>Caution: Device damage may result if ...</p> <p>A Caution identifies conditions or inappropriate usage of the product that could lead to undesirable results or product damage. In the online version of this book, the word Caution appears instead of this symbol.</p>
	<p>Warning: Injury to device users may result if ...</p> <p>A Warning identifies conditions or inappropriate usage of the product that could lead to conditions that are potentially hazardous for the devices users. In the online version of this book, the word Warning appears instead of this symbol.</p>

Notation Conventions

1 USING ADSP-CM403F EZ-KIT LITE

This chapter provides information to assist you with development of programs for the ADSP-CM403F EZ-KIT Lite evaluation system.

The following topics are covered.

- [Package Contents](#)
- [ADSP-CM403F EZ-Board](#)
- [Default Configuration](#)
- [IAR Embedded WorkBench and Board Installation](#)
- [IAR Embedded WorkBench Session Startup](#)
- [SPI Flash](#)
- [Analog Interface](#)
- [UART0 Interface \(RS-232\)](#)
- [CAN0 Interface](#)
- [Debug Interface](#)
- [Serial Liquid Crystal Display Module Interface](#)
- [Power-On-Self Test](#)
- [Expansion Interface](#)
- [Power Architecture](#)

Package Contents

- [Power Measurements](#)
- [Example Programs](#)
- [Reference Design Information](#)

For detailed information on how to program the ADSP-CM403F processor, refer to the documents listed in the [Preface](#).

Package Contents

Your ADSP-CM403F EZ-KIT Lite package contains the following items:

- ADSP-CM403F EZ-KIT Lite board
- Universal 5V DC power
- J-Link Lite ARM (only in the EZ-KIT Lite version)

Contact the vendor where you purchased your EZ-KIT Lite or contact Analog Devices, Inc. if any item is missing.

ADSP-CM403F EZ-Board

The ADSP-CM403F EZ-KIT Lite is shipped with the J-Link Lite ARM debugger. When the product is not shipped with the debugger, it is referred to as the ADSP-CM403F EZ-Board.

 The EZ-Board requires a third party emulator.

Default Configuration

The ADSP-CM403F EZ-KIT Lite board is designed to run outside your personal computer as a standalone unit.

When removing the EZ-KIT Lite board from the package, handle the board carefully to avoid the discharge of static electricity, which can damage some components.

The EZ-KIT Lite evaluation system contains ESD (electrostatic discharge) sensitive devices. Electrostatic charges readily accumulate on the human body and equipment and can discharge without detection. Permanent damage may occur on devices subjected to high-energy discharges. Proper ESD precautions are recommended to avoid performance degradation or loss of functionality. Store unused EZ-KIT Lite boards in the protective shipping package.



Default Configuration

Figure 1-1 shows the default jumper and boot mode switch settings used in installation. Confirm that your board is in the default configuration before using the board.

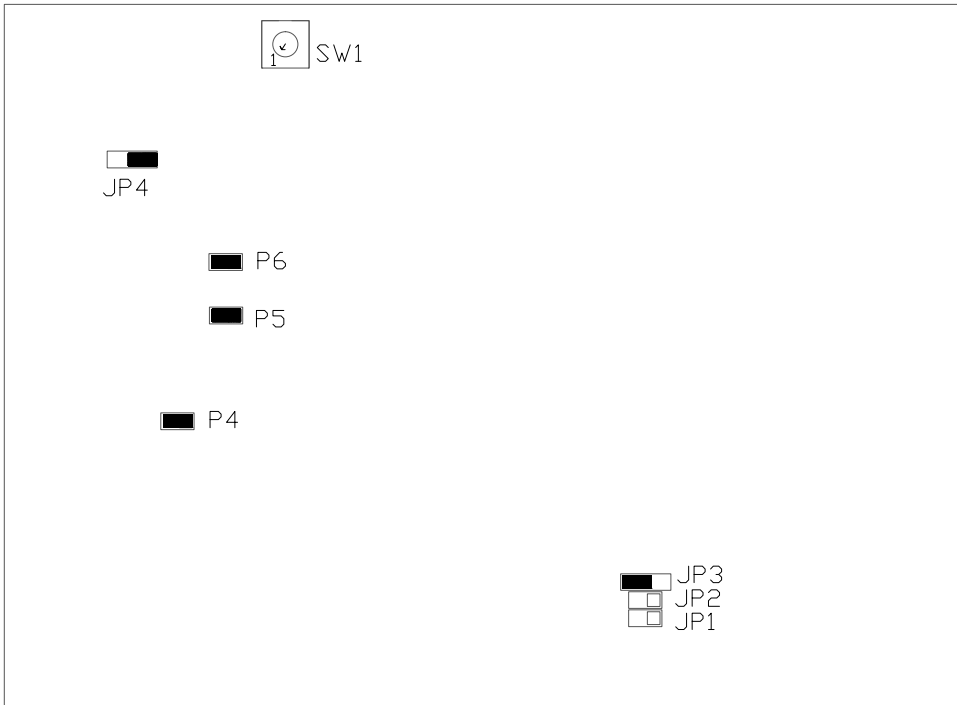

Figure 1-1. Default EZ-KIT Lite Hardware Setup

IAR Embedded WorkBench and Board Installation

For information about the IAR Embedded WorkBench[®] product and software download, go to:

<http://www.iar.com/en/Products/IAR-Embedded-Workbench>

The ADSP-CM403F EZ-KIT Lite software, based on the IAR Embedded WorkBench, can be found at:

<http://www.analog.com/CM403FEZKit>

Follow these instructions to ensure correct operation of the product software and hardware.

Step 1: Connect the EZ-KIT Lite board to a personal computer (PC) running **IAR Embedded WorkBench** using a J-Link/J-Trace emulator.

1. Plug one side of the USB cable into the USB connector of the emulator. Plug the other side into a USB port of the PC running **IAR Embedded WorkBench**.
2. Attach the emulator to the header connector, P1 or P2, on the EZ-KIT Lite board.

Step 2: Attach the provided cord and appropriate plug to the 5V power adaptor.

1. Plug the jack-end of the power adaptor into the power connector P7 (labeled 5V) on the EZ-KIT Lite board.
2. Plug the other side of the power adaptor into a power outlet. The power LED (labeled LED5) is lit green when power is applied to the board.

IAR Embedded WorkBench Session Startup

It is assumed that the **IAR Embedded WorkBench** software is installed and running on your PC.

1. Navigate to the **IAR Embedded WorkBench** environment via the **Start** menu.

Note that IAR Embedded WorkBench is not connected to the target board.

2. Choose **File > Open > Workspace** to open a workspace for the project to download and debug.
3. Choose **Project > Options**.

The **General Options, Target** page appears.

4. In **Processor variant**, ensure **Device** is **AnalogDevices ADSP-CM40z-X_Y**, where **X** is the SRAM size in KB and **Y** is the internal flash size in KB of the part on the target board.

On the Analog Devices ADSP-CM403F EZ-KIT Lite, SRAM size is 384 KB, and internal flash size is 2048 KB.

5. Choose **Debugger** in the **Category** pane.

The **Debugger, Setup** options page appears.

- a. In **Driver**, choose **J-Link/J-Trace** as the emulator to be used to debug the target board.
- b. Click the **Download** tab. The **Debugger, Download** options page appears.
- c. Ensure **Use flash loader(s)** is enabled. Note that other download settings are optional.

6. Choose **Debugger > J-Link/J-Trace** in the **Category** pane.

The emulator **Setup** options page appears.

- a. On the **Setup** page,
 - In **Reset**, select **Connect during reset** from the drop-down list.
 - In **JTAG/SWD speed**, select **Auto**.
 - (Optional) In **Clock setup**, change the default values.
 - b. On the **Connection** page,
 - In **Communication**, select **USB** and **Device 0**.
 - In **Interface**, select **JTAG** or **SWD**.
7. Click **OK** to save the emulator settings.
 8. Choose **Project > Debug and Download** to download the project and start debugging.

SPI Flash

The EZ-KIT Lite ships with an internal 4 MB SPI flash, connected via the SPI2 interface, which is used for booting and scratchpad space. Refer to the *ADSP-CM40x Mixed-Signal Control Processor Hardware Reference* for more information about the internal SPI flash.

For more information, refer to the SPI flash example in the POST, which is included in the ADSP-CM40x Enablement Software.

Analog Interface

The ADSP-CM403F processor provides two 16-bit ADCs with 12 inputs each, ADC0 and ADC1. The ADC signals are connected to the Analog expansion connector (J9). There are also two 12-bit DACs available on J9. Refer to [ADSP-CM403F EZ-KIT Lite Schematic](#) for more information.

Voltage reference for the ADC channels can be supplied internally from the processor or externally by ADR441 ICs. U6 is the VREF0 supply external source, and U2 is its VREF1 equivalent. To select the external source for either supply, place a jumper on JP1 or JP2. Refer to [ADSP-CM403F EZ-KIT Lite Schematic](#) for more information.

A buffered version of the voltage reference is available on J9 via a unity gain buffer ADA4889 (U22). By default, the internal VREF0 source is selected as the input to the buffer (JP3 positions 1 and 2). If the external voltage reference is desired, change the jumper to JP3 positions 2 and 3.

Voltage references for the analog inputs are configurable; refer to [Jumpers](#) for more information.

UART0 Interface (RS-232)

The ADSP-CM403F processor has three built-in universal asynchronous transmitters (UARTs). UART0 is connected to a RS-232 line transmitter. UART0 has full RS-232 functionality via the Analog Devices ADM3252E isolated line driver and receiver (U23).

 The EZ-KIT Lite voltage isolation components are not intended for protecting external products. The isolated ICs are used to show-case Analog Devices product portfolio only. Adequate voltage isolation of any external devices/boards is the user responsibility.

Pin PC_02/UART0_TX/TRACE_D03/SPIO_RDY of the processor is connected to the ADM3315 device directly and used for UART transmit.

Pin PC_01/UART0_RX/SMCO_A05/TM0_ACI5 is connected through SoftConfig by default and used for UART receive. (This can be changed through SoftConfig.)

By default, the UART0 CTS signal is not connected, and the UART0 RTS signal is connected to RS-232. Both connections can be changed through SoftConfig.

The SoftConfig switches also allow the loopback of CTS and RTS. The UART0 CTS can be added as an input to the reset circuit through SoftConfig. Refer to [Software-Controlled Switches \(SoftConfig\)](#) for more information.

For more information, refer to the UART example in the POST, which is included in the ADSP-CM40x Enablement Software. Note that the loopback of TX and RX data is done through an external connector.

CAN0 Interface

The Controller Area Network 0 (CAN0) interface of the EZ-KIT Lite is connected to the Analog Devices ADM3053 isolated CAN transceiver (U26). The transceiver is attached to the CAN0 port of the ADSP-CM403F processor via an RJ-11 connector (J8). See [CAN0 Connector \(J8\)](#).

 The EZ-KIT Lite voltage isolation components are not intended for protecting external products. The isolated ICs are used to showcase Analog Devices product portfolio only. Adequate voltage isolation of any external devices/boards is the user responsibility.

The CAN0 transmit and receive signals are connected through the Soft-Config switches and enabled by default. See [Software-Controlled Switches \(SoftConfig\)](#).

For more information, refer to the CAN0 example in the POST, which is included in the ADSP-CM40x Enablement Software.

Debug Interface

The EZ-KIT Lite provides a JTAG/SWD/SWV connection via a connector (P1), which is a 0.1" header. A 4-bit trace connection also includes JTAG/SWD/SWV and is available via a connector (P2). See [JTAG/SWD/SWV Connector \(P1\)](#) and [TRACE and JTAG/SWD/SWV Connector \(P2\)](#) for more information.

Serial Liquid Crystal Display Module Interface

Connector J3 mates with the Newhaven Display International NHD-0220D3Z-FL-GBW-V3, a 2-line by 20-character display with a yellow/green backlight.

The display is written using the TWI interface. The TWI address of the display is 0x50. The maximum clock rate for the display is 100 kHz. The display can be removed if the frequency limitation poses a problem.

For more information, refer to the serial liquid crystal display example in the POST, which is included in the ADSP-CM40x Enablement Software.

Power-On-Self Test

The Power-On-Self-Test Program (POST) tests all EZ-KIT Lite peripherals and validates functionality as well as connectivity to the processor. Once assembled, each EZ-KIT Lite is fully tested for an extended period of time with POST. All EZ-KIT Lite boards are shipped with POST pre-loaded into flash memory. The POST is executed by resetting the board and pressing the proper push button(s). The POST also can be used as a reference for a custom software design or hardware troubleshooting.

Note that the source code for the POST program is included in the ADSP-CM40x Enablement Software along with the `readme.txt` file that describes how the board is configured to run POST.

Expansion Interface

The expansion interface allows a custom-design daughter board to be tested across various hardware platforms that have the same expansion interface.

The expansion interface implemented on the ADSP-CM403F EZ-KIT Lite consists of three connectors: [Asynch or Memory Connector \(J2\)](#), [PWM Connector \(J7\)](#), and [Analog Connector \(J9\)](#). The connectors contain a majority of the processor's signals. For pinout information, go to [ADSP-CM403F EZ-KIT Lite Schematic](#).

Power Architecture

Limits to current and interface speed must be taken into consideration when using the expansion interface. Current for extenders connected to J2 or J6 can be sourced from the EZ-KIT Lite; therefore, the current should be limited to 250 mA for 5V, and 200 mA from the 3.3V planes. If more current is required, a separate power connector and a regulator must be designed on the daughter card. Additional circuitry implemented on extender cards can add extra loading to signals, decreasing their maximum effective speed.

 Analog Devices does not support and is not responsible for the effects of additional circuitry.

Power Architecture

The ADSP-CM403F EZ-KIT Lite has two primary voltage domains: 3.3V and 1.2V. The main input is a 5V wall adaptor. The 5V source can be selected via JP4 to input from the PWM connector (J7) as an alternative to the wall power adaptor. Refer to [PWM Connector \(J7\)](#) and [Power Select Jumper \(JP4\)](#) for details.

The Analog Devices ADP2119 controller provides 3.3V for the VDD_EXT signal and the 3.3V power requirements of the board. The VDD_INT signal is delivered through either Analog Devices regulator ADP2119 (VR1) or a PNP transistor (Q1).

Power Measurements

Locations are provided for measuring the current draw from various power planes. Precision 0.05 ohm shunt resistors are available on the VDD_EXT, VDD_INT, and 3.3V voltage domains. For current draw, the jumper is removed, voltage across the resistor can be measured using an oscilloscope, and the value of the resistor can be measured using a precision multi-meter. Once voltage and resistance are measured, the current

can be calculated by dividing the voltage by the resistance. For the highest accuracy, a differential probe should be used for measuring the voltage across the resistor. For more information, refer to [Power Jumpers \(P4–6\)](#).

Example Programs

Example programs are provided with the ADSP-CM40x Enablement Software to demonstrate various capabilities of the product. The programs can be found in the `CM403F_CM408F_EZ-KIT\examples` folder. Refer to a readme file provided with each example for more information.

Reference Design Information

A reference design info package is available for download on the Analog Devices Web site. The package provides information on the design, layout, fabrication, and assembly of the EZ-KIT Lite.

The information can be found at:

<http://www.analog.com/CM403FEZKit>

Reference Design Information

2 ADSP-CM403F EZ-KIT LITE HARDWARE REFERENCE

This chapter describes the hardware design of the ADSP-CM403F EZ-KIT Lite board.

The following topics are covered.

- [System Architecture](#)
Describes the board's configuration and explains how the board components interface with the processor.
- [Software-Controlled Switches \(SoftConfig\)](#)
Lists and describes the processor signals routed through the software-controlled switches.
- [Push Buttons and Switches](#)
Shows the locations and describes the push buttons and switches.
- [Jumpers](#)
Shows the locations and describes the configuration jumpers.
- [LEDs](#)
Shows the locations and describes the LEDs.
- [Connectors](#)
Shows the locations and provides part numbers for the on-board connectors. In addition, the manufacturer and part number information is provided for the mating parts.

System Architecture

This section describes the processor's configuration on the EZ-KIT Lite (Figure 2-1).

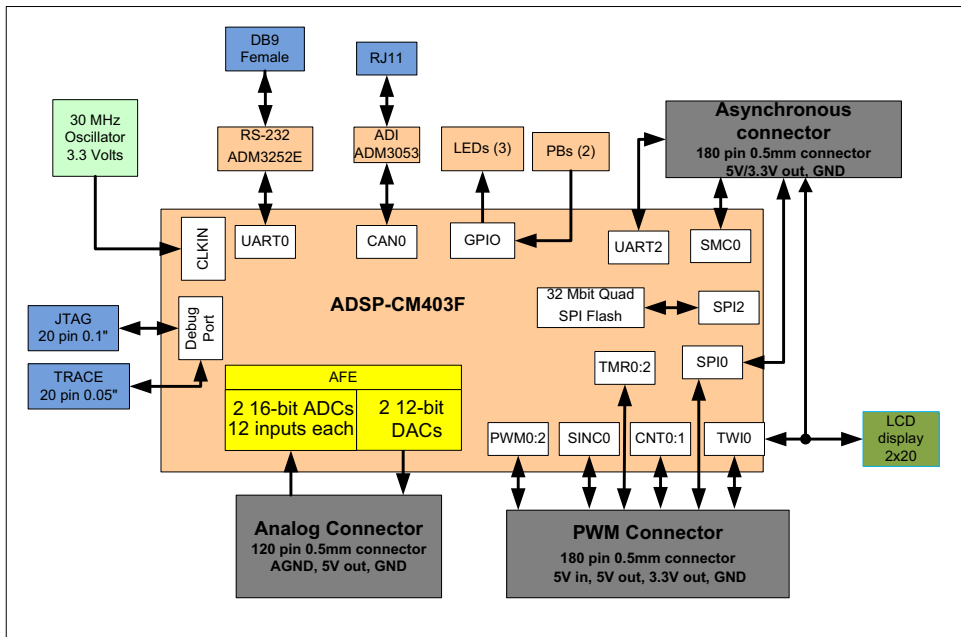

Figure 2-1. EZ-KIT Lite Block Diagram

This EZ-KIT Lite is designed to demonstrate the ADSP-CM403F processor's capabilities. The ADSP-CM403F EZ-KIT Lite has a 30 MHz input clock and runs at 240 MHz internally.

User I/O to the processor is provided in the form of two user push buttons and three LEDs. The software-controlled switches (SoftConfig) facilitate the switch multi-functionality by disconnecting the push buttons from their associated processor pins and reusing the pins elsewhere on the board. See [ADSP-CM403F EZ-KIT Lite Schematic](#) for more information.

Software-Controlled Switches (SoftConfig)

On the ADSP-CM403F EZ-KIT Lite, most of the traditional mechanical switches have been replaced by I²C software-controlled switches. The remaining mechanical switches are provided for changing the boot mode and push buttons. Reference any `SoftConfig*.c` file found in the installation directory for an example of how to set up the SoftConfig feature of the ADSP-CM403F EZ-KIT Lite through software.

The SoftConfig section of this manual serves as a reference to any user that intends to modify an existing software example. If software provided from ADI is used, there should be little need to reference this section.

 Care should be taken when changing SoftConfig settings not to create a conflict with interfaces. This is especially true when connecting extender cards.

Overview of SoftConfig

In order to further clarify the use of electronic single FET switches and multi-channel bus switches, an example of each is illustrated and compared to a traditional mechanical switching solution. This is a generic example that uses the same FET and bus switch components that are on the EZ-KIT Lite.

After this generic discussion there is a detailed explanation of the SoftConfig interface specific to the ADSP-CM403F EZ-KIT Lite.

Software-Controlled Switches (SoftConfig)

Figure 2-2 shows two individual FET switches (Pericom PI3A125CEX) with reference designators UA and UB. Net names `ENABLE_A` and `ENABLE_B` control UA and UB. The default FET switch enable settings in this example are controlled by resistors `RA` and `RB` which pull the enable pin 1 of UA and UB to ground (low). In a real example, these enable signals are controlled by the Microchip IO expander. The default pull-down resistors connects the signals `EXAMPLE_SIGNAL_A` and `EXAMPLE_SIGNAL_B` and also connects signals `EXAMPLE_SIGNAL_C` and `EXAMPLE_SIGNAL_D`. To disconnect `EXAMPLE_SIGNAL_A` from `EXAMPLE_SIGNAL_B`, the Microchip IO expander is used to change `ENABLE_A` to a logic 1 through software that interfaces with the Microchip. The same procedure for `ENABLE_B` disconnects `EXAMPLE_SIGNAL_C` from `EXAMPLE_SIGNAL_D`.

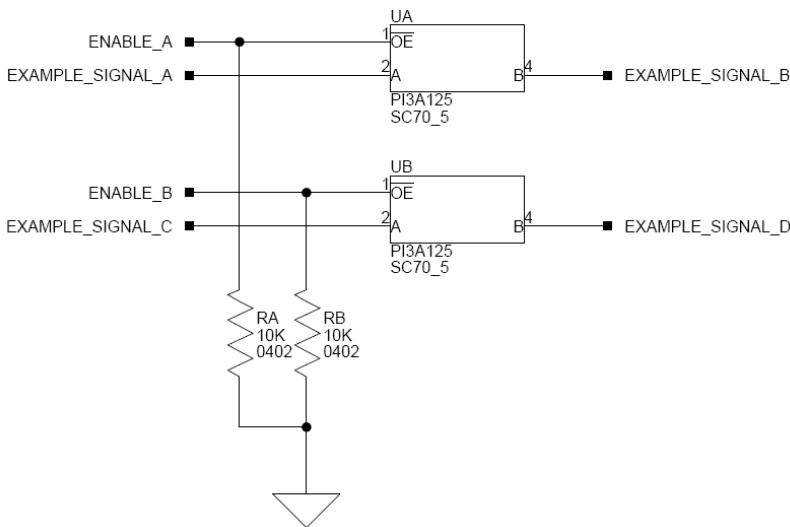

Figure 2-2. Example of Individual FET Switches

Figure 2-3 shows the equivalent circuit to Figure 2-2 but utilizes mechanical switches that are in the same package. Notice the default is shown by black boxes located closer to the ON label of the switches. In order to disconnect these switches, physically move the switch to the OFF position.

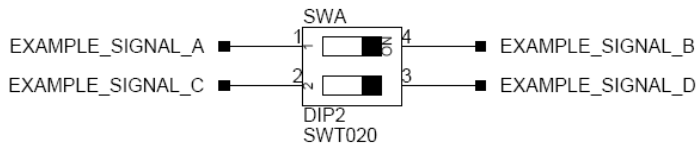

Figure 2-3. Example of Mechanical Switch Equivalent to Figure 2-2

Figure 2-4 shows a bus switch example, reference designator UC (Pericom PI3LVD512ZHE), selecting between lettered functionality and numbered functionality. The signals on the left side are multiplexed signals with naming convention `letter_number`. The right side of the circuit shows the signals separated into letter and number, with the number on the lower group (eg. `OB1`) and the letter on the upper group (eg. `OB2`). The default setting is controlled by the signal `CONTROL_LETTER_NUMBER` which is pulled low. This selects the number signals on the right to be connected to the multiplexed signals on the left by default. In this example, the Microchip IO expander is not shown but controls the signal `CONTROL_LETTER_NUMBER` and allows the user to change the selection through software.

Figure 2-5 shows the equivalent circuit to Figure 2-4 but utilizes mechanical switches. Notice the default for reference designators `SWC` and `SWD` is illustrated by black boxes located closer to the ON label of the switches to enable the number signals by default. Also notice the default setting for reference designators `SWE` and `SWF` is OFF. In order to connect the letters instead of the numbers, the user physically changes all switches on `SWC` and `SWD` to the OFF position and all switches on `SWE` and `SEF` to the ON position.

Software-Controlled Switches (SoftConfig)

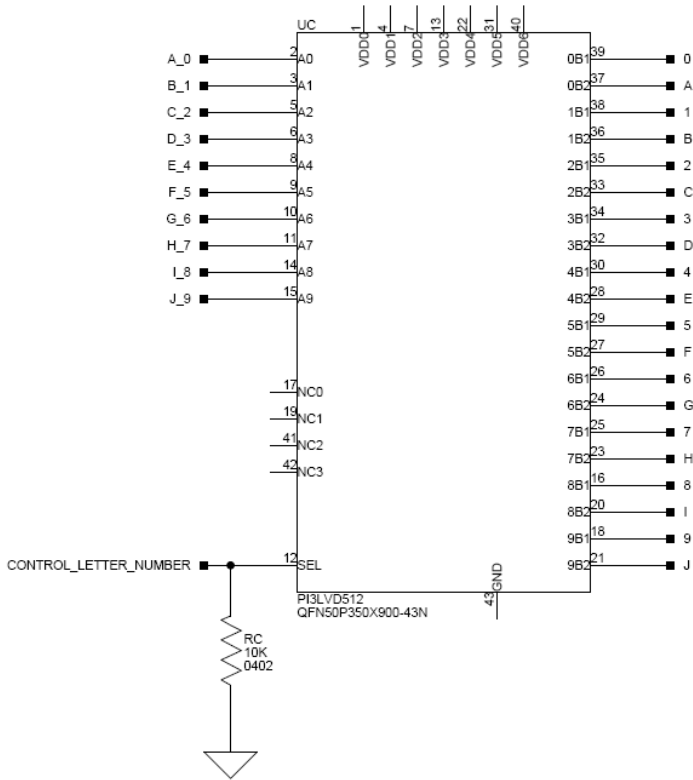

Figure 2-4. Example of Bus Switch

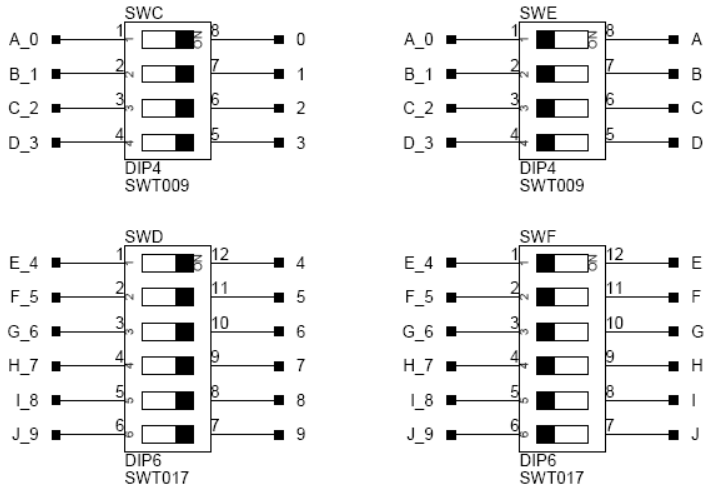

Figure 2-5. Example of Mechanical Switch Equivalent to [Figure 2-4](#)

SoftConfig on the ADSP-CM403F EZ-KIT LITE

The Microchip MCP23017 GPIO expander (U27) provides control for individual electronic switches. The TWI0 interface of the processor communicates with the Microchip device.

[Table 2-1](#) lists the ADSP-CM403F processor and EZ-KIT Lite interfaces that are available by default. Note that only interfaces affected by software switches are listed in [Table 2-1](#).

Software-Controlled Switches (SoftConfig)

Table 2-1. Default ADSP-CM403F Processor Interface Availability

Interface	Availability by Default
UART0	RS-232 RX, TX and RTS enabled by default. SoftConfig required for other functionality.
CAN0	Enabled in hardware, disabled in software to use LED1.
Push buttons	Enabled
LEDs	Enabled

Programming SoftConfig Switches

On the ADSP-CM403F EZ-KIT Lite, one Microchip MCP23017 device exists. The device has the following programming characteristics:

- Each switch has two programmable GPIO registers.

GPIO Register	Register Address
GPIOA	0x12
GPIOB	0x13

- Each GPIO register controls eight signals (software switches).
- By default, the Microchip MCP23017 GPIO signals function as input signals.

The signals must be programmed as output signals to override their default values. The following table shows the Microchip register addresses and the values that must be written to them to program the signals as output signals.

IODIR Register	IODIR Register Address	Value to be Written to Program Signals as Outputs
IODIRA	0x00	0
IODIRB	0x01	0

Each of the software examples include a source file that programs the soft switches, even if the default settings are being used. The `README` for each example identifies only the signals that are being changed from their default values. The code that programs the soft switches is located in the `SoftConfig_CM408F.c` file in each example.

[Table 2-2](#) outlines the default values for the Microchip MCP23017 device.

Table 2-2. I²C Hardware Address 0x40

GPIO	MCP23017 Register Address	Default Value
GPIOA	0x12	0xE0
GPIOB	0x13	0xC1

The [ADSP-CM403F EZ-KIT Lite Schematic](#) shows how the Microchip GPIO expander (U27) is connected to the board's ICs. All outputs drive single signal FET switches. The CAN0 and LED1 circuits both use processor port pin `PB_15`, and can be selected through `SoftConfig`. CAN0 enable (`CAN0_EN0`) controls whether the CAN port is enabled or the signals are connected to the expansion interface. When `CAN0_EN` is low, the CAN interface is enabled and the processor signals (`PC_00` and `PB_15`) are not connected to the expansion interface. A `CAN0_EN` setting of high connects the signals to the expansion interface and disconnects the CAN port. This is done through the inverter IC (U3).

[Table 2-3](#) and [Table 2-4](#) show the output signals of the Microchip GPIO expander (U27), with a TWI address of 0100 001X, where X represents the read or write bit. The signals that control an individual FET have an entry under the **FET** column. The **Component Connected** column shows the board IC that is connected if the FET is enabled. Also note that if a particular functionality of the processor signal is being used, it will be in **bold font** under the **Processor Signal** column.

Software-Controlled Switches (SoftConfig)

Table 2-3. Output Signals of Microchip GPIO Expander (U27 Port A)

Bit	Signal Name	Description	FET	Processor Signal (if applicable)	Component Connected	Default
0		Not used				Low
1	PB_10_J7_EN	Processor pin PB_10 connection to expansion connector J7	U8	PB_10/SINCO_CLK0/ SPI0_D2/CAN1_RX/ SMCO_AWE/TMO_AC11		Low
2	PB_11_J7_EN	Processor pin PB_11 connection to expansion connector J7	U9	PB_11/SINCO_D0/ SPI0_D3/CAN1_TX/ SMCO_AMS0/TMO_ACLK1		Low
3	UARTORTS_EN	UART0 RTS connected to RS-232 transceiver	U10	PB_04/PWM2_SYNC/ UART0_RTS/SPT0_ ATDV/SMCO_D12/CNT1_ UD	U23	Low
4	UARTORX_EN	UART0 RX connected to RS-232 transceiver	U11	PC_01/UART0_RX/ SMCO_A05/TMO_AC15	U23	Low
5	UARTOCTS_EN	UART0 CTS disconnected from RS-232 transceiver by default	U12	PB_05/PWM2_TRIP0/ UART0_CTS/TMO_TMR7/ SMCO_D13/CNT1_DG	U36	High
6	UARTOCTS_RTS_LPBK	UART0 CTS and RTS not connected. Change to low for looping back RS-232 CTS and RTS signals	U13		U36	High
7	UARTOCTS_RST_EN	UART0 CTS signal not connected to input of reset IC	U14		U36	High

ADSP-CM403F EZ-KIT Lite Hardware Reference

Table 2-4. Output Signals of Microchip GPIO Expander
(U27 Port B)

Bit	Signal Name	Description	FET	Processor Signal (if applicable)	Component Connected	Default
0	CANO_EN	Enables CAN 0, enabled by default	U15/ U16	PC_00/CANO_TX/ SPT1_BT DV/UART1_ TX/SMCO_A04 and PB_ 15/CANO_RX/SPT1_ ATDV/UART1_RX/ SMCO_A03/TMO_AC14	U26	Low
1	PUSHBUTTON1_EN	PF_10 is used as GPIO input for push button 1, enabled by default	U21	PF_10/ETH0_ PTPCLKIN	U39	Low
2	PUSHBUTTON2_EN	PE_08 is used as GPIO input for push button 2, enabled by default	U20	PE_08/ETH0_PTPPPS/ SMCO_A22/CNT2_ZM	U39	Low
3	LED1_GPIO_EN	PE_07 is used as GPIO output for LED1, enabled by default	U19	PE_07/ETH0_ PTPAUXIN/SMCO_A21	U5	Low
4	LED2_GPIO_EN	PE_06 is used as GPIO output for LED2, enabled by default	U18	PE_06/SMCO_A20	U5	Low
5	LED3_GPIO_EN	PE_05 is used as GPIO output for LED3, enabled by default	U17	PE_05/SMCO_A19	U5	Low
6	TRACE_EXP_EN	Signals not connected to expansion interface	U51- 55	PB_00, PB_01, PB_ 02, PB_03, PC_02	J2, J7	High
7	SPIFLASH_J2_EN	Signals not connected to expansion interface by default	U32- 36	PC_03, PC_05, PC_ 04, PB_10, PB_11	J2	High

Push Buttons and Switches

This section describes operation of the push buttons and switches. The push button and switch locations are shown in [Figure 2-6](#).

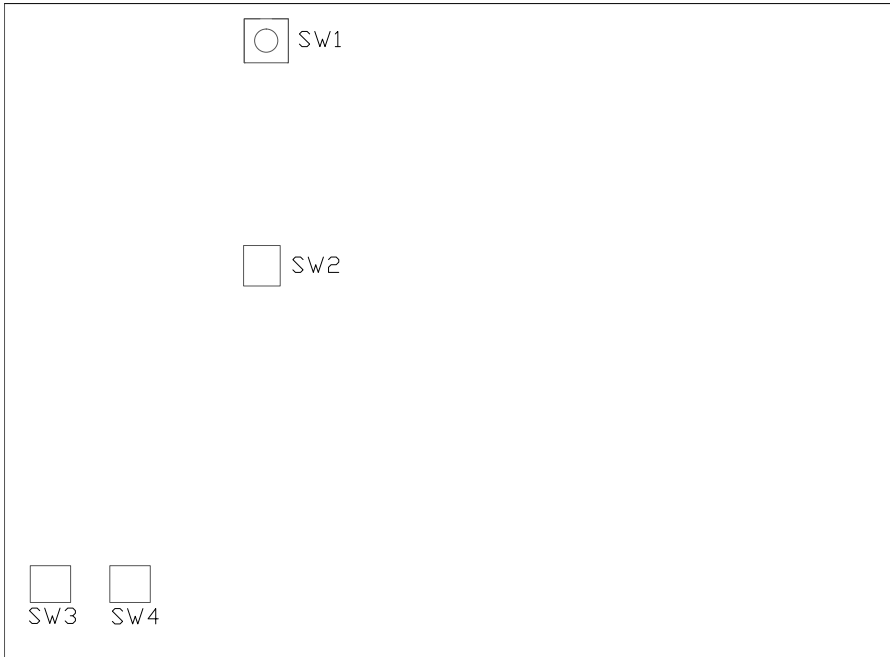

Figure 2-6. Push Button and Boot Mode Switch Locations

Boot Mode Select Switch (SW1)

The rotary switch (SW1) determines the boot mode of the processor. [Table 2-5](#) shows the available boot mode settings. By default, the ADSP-CM403F processor boots from the on-board burst flash memory.

Table 2-5. Boot Mode Select Switch (SW1)

SW1 Position	Processor Boot Mode
0	No Boot – Idle
1	SPI master boot (internal SPI2). Default boot mode.
2	SPI slave boot (SPI0)
3	UART boot (UART0)

Reset Push Button (SW2)

The reset push button (SW2) resets the processor (U1) and the GPIO extender (U27). The reset also is connected to the expansion interface via the $\overline{\text{SYS_HWRST}}$ signal.

GPIO Push Buttons (SW3-4)

The GPIO push buttons (SW3 and SW4) are connected to the processor's signals PB_06/PWM2_AH/TMO_CLK/SMC0_D14 and PB_07/PWM2_AL/TMO_TMR0/SMC0_D15, respectively. The signals are connected by default.

Jumpers

This section describes functionality of the configuration jumpers. [Figure 2-7](#) shows the jumper locations.



Figure 2-7. Jumper Locations

VREF0 External Source Jumper (JP1)

The VREF0 external source jumper (JP1) selects whether an internal or external voltage reference supplies the VREF0 signal of the processor. When a jumper on JP1 is not installed (default), the internal voltage reference supplies VREF0. When a jumper on JP1 is installed, the external Analog Devices ADR441 ultra-low noise voltage reference (U6) supplies VREF0. Configure the processor's registers accordingly for the latter case.

VREF1 External Source Jumper (JP2)

The VREF1 external source jumper (JP2) selects an internal or external voltage reference supply to the VREF1 signal of the processor. When a jumper on JP2 is not installed (default), the internal voltage reference supplies VREF1. When a jumper on JP2 is installed, the external Analog Devices ADR441 ultra-low noise voltage reference (U2) supplies VREF1. Configure the processor's registers accordingly for the latter case.

Buffer Input Select Jumper (JP3)

The buffer input select jumper (JP3) selects the input to the ADA4889 unity gain op amp buffer (U22). The processor's internal input is selected by placing a jumper on pins 1 and 2 of JP3 (default).

The external VREF0 input, supplied by the Analog Devices ADR441 ultra-low noise voltage reference (U6), is selected by placing a jumper on pins 2 and 3 of JP3.

Jumpers

Power Select Jumper (JP4)

The power select jumper (JP4) selects the wall power (5V) when a jumper is placed on positions 1 and 2. When a jumper is placed on positions 2 and 3, power from pins 177, 178, 179 and 180 of the PWM connector (J7) is supplied to the board. The default setting is positions 1 and 3, which selects wall power.

Power Jumpers (P4–6)

Remove jumpers listed in [Table 2-6](#) to measure the respective voltage across the adjacent sense resistor.

Table 2-6. Power Jumpers

Power Jumper	Resistor
P4	VDD_INT
P5	VDD_EXT
P6	3.3V

LEDs

This section describes the on-board LEDs. [Figure 2-8](#) shows the LED locations.

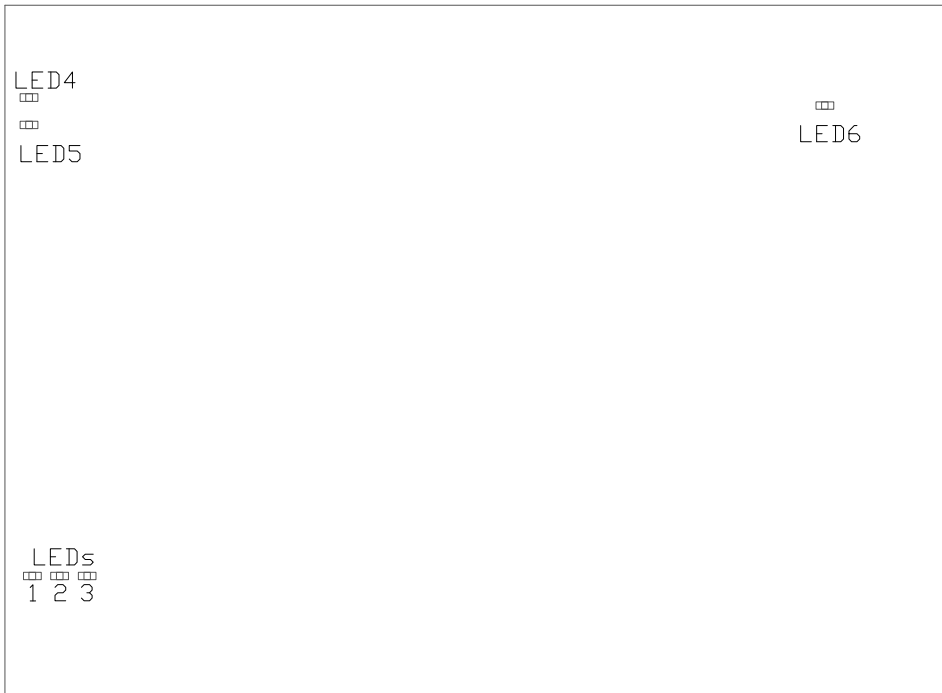

Figure 2-8. LED Locations

LEDs

GPIO LEDs (LED1–3)

Three LEDs are connected to the general-purpose I/O pins of the processor (see [Table 2-7](#)). The LEDs are active high and are ON (amber) by writing a 1 to the correct processor signal.

Table 2-7. GPIO LEDs

LED Reference Designator	Processor Programmable Flag Pin
LED1	PB_15
LED2	PB_04
LED3	PB_05

Reset LED (LED4)

When LED4 is ON (red), it indicates that the master reset of all the major ICs is active. The reset LED is controlled by the Analog Devices ADM708 supervisory reset circuit. A master reset is asserted by pressing SW2 which activates LED4. For more information, see [Reset Push Button \(SW2\)](#).

Power LED (LED5)

When LED5 is ON (green), it indicates that power is being supplied to the board properly. For more information, see [Power Architecture](#).

SYS_FAULT LED (LED6)

When LED6 is ON (red), it indicates a system fault. For more information, refer to the *ADSP-CM40x Mixed-Signal Control Processor Hardware Reference*.

Connectors

This section describes connector functionality and provides information about mating connectors. The connector locations are shown in [Figure 2-9](#).

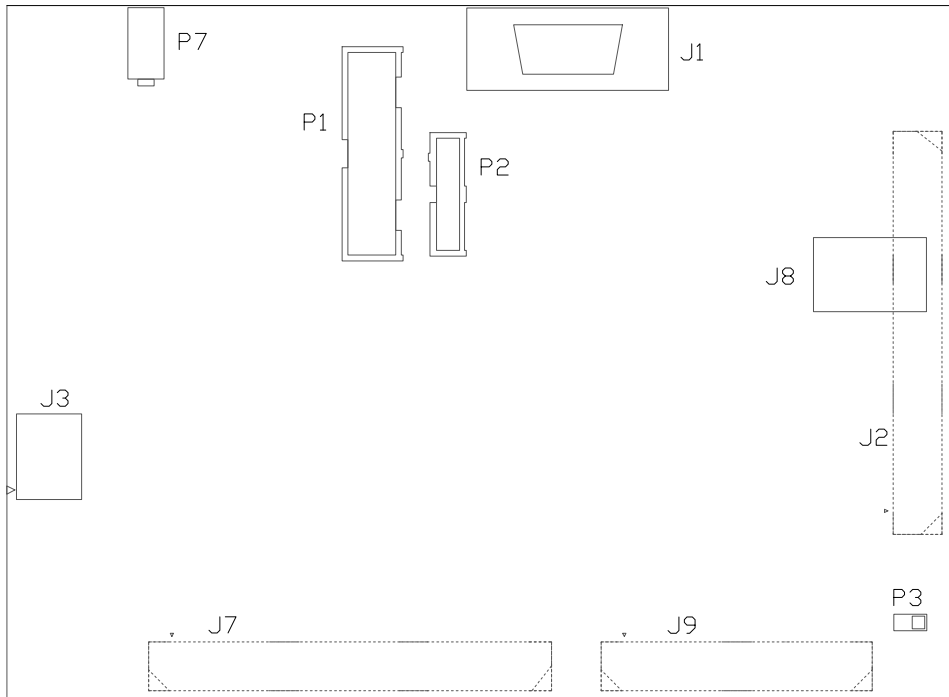

Figure 2-9. Connector Locations

i Connectors on the back of the board are noted with dotted lines.

Connectors

DCE UART Connector (J1)

Part Description	Manufacturer	Part Number
DB9 female	NORCOMP	191-009-213-L-571

Asynch or Memory Connector (J2)

Part Description	Manufacturer	Part Number
180-pin high speed socket	SAMTEC	QSH-090-F-D_A
Mating Connector		
180-pin high speed header	SAMTEC	QTH-090-01-F-D-A

Character Display Connector (J3)

The character display connector (J3) is a socket that mates with the 20×2 character display.

Part Description	Manufacturer	Part Number
IDC 5x2 SMT	SAMTEC	SSW-105-22-F-D-VS
Mating Connector		
20x2 character display with back-light	NEW HAVEN DISPLAY	NHD-0220D3Z-FL-GBW (requires header)

PWM Connector (J7)

Part Description	Manufacturer	Part Number
180-pin high speed socket	SAMTEC	QSH-090-F-D_A
Mating Connector		
180-pin high speed header	SAMTEC	QTH-090-01-F-D-A

CAN0 Connector (J8)

Part Description	Manufacturer	Part Number
RJ11 vertical	DIGIKEY	A31431-ND
Mating Connector		
RJ11 cable		

Analog Connector (J9)

Part Description	Manufacturer	Part Number
120-pin high speed socket	SAMTEC	QSH-060-F-D_A
Mating Connector		
120-pin high speed header	SAMTEC	QTH-060-01-F-D-A

JTAG/SWD/SWV Connector (P1)

The JTAG/SWD/SWV header (P1) provides debug connectivity for the microprocessor. This is a 0.1" connector from SAMTEC (SHF-110-01-L-D-TH). For more information, see [Debug Interface](#).

Connectors

TRACE and JTAG/SWD/SWV Connector (P2)

The TRACE and JTAG/SWD/SWV Connector (P2) provides connectivity to the microprocessor's trace interface. This is a 0.05" connector from TE Connectivity (5103308-5).

Pin 7 is cut to provide keying.

Refer to the SoftConfig tables for information on enabling the Trace signals, specifically the `TRACE_EXP_EN` signal.

VREF Buffered Connector (P3)

The VREF buffered connector provides a means to measure the voltage of the voltage reference. There is an adjacent analog grounding point (TP11).

Power Connector (P7)

Part Description	Manufacturer	Part Number
0.65 mm power jack	CUI	045-0883R
Mating Connector		
5.0VDC@3.6A power supply	GLOBETEK	GS-1750(R)

A ADSP-CM403F EZ-KIT LITE BILL OF MATERIALS

The bill of materials corresponds to [ADSP-CM403F EZ-KIT Lite Schematic](#).

Ref.	Qty	Description	Reference Designator	Manufacturer	Part Number
1	1	ADM708SARZ SOIC8	U28	ANALOG DEVICES	ADM708SARZ
2	1	ADP2119ACPZ-R7 DFN50P300X300-11N	VR1	ANALOG DEVICES	ADP2119ACPZ-R7
3	2	ADR441ARMZ MSOP8	U2,U6	ANALOG DEVICES	ADR441ARMZ
4	1	ADP2118ACPZ QFN65P400X400X80-17N	VR2	ANALOG DEVICES	ADP2118ACPZ
5	1	ADA4899 SOIC8	U22	ANALOG DEVICES	ADA4899-1YRDZ-R7
6	1	ADM3252E BGA44C100P11X11_1200X1200X103	U23	ANALOG DEVICES	ADM3252EABCZ
7	1	ADM3053 SOIC127P1032X265-20N	U26	ANALOG DEVICES	ADM3053BRWZ
8	1	ADSP-CM403FBSWZ QFPS40P1600X1600X160-121N	U1	ANALOG DEVICES	ADSP-CM403FBSWZENG

Ref.	Qty	Description	Reference Designator	Manufacturer	Part Number
9	47	0.1UF 10V 10% 0402	C1,C7,C8,C11,C13,C16,C19,C22,C25-C30,C33,C42-C44,C49,C51,C52,C55,C56,C60,C63-C66,C68,C72-C74,C76,C77,C79,C95,C99-C104,C111,C113-C115,C174	AVX	0402ZD104KAT2A
10	37	0.01UF 16V 10% 0402	C4-C6,C21,C23,C34-C40,C48,C67,C69,C71,C80-C89,C105-C110,C112,C170-C173	AVX	0402YC103KAT2A
11	1	10UF 16V 10% 1210	C93	AVX	1210YD106KAT2A
12	2	1000PF 50V 5% 1206	C92,C94	AVX	12065A102JAT2A
13	2	680 1/16W 1% 0402	R140,R141	BC COMPONENTS	2312 275 16801
14	2	1.5UH 20% IND003	L1,L2	COIL CRAFT	DO1608C-152MLC
15	1	ROTARY SWT027	SW1	COPAL	S-8110
16	1	MCP23017 QFN65P600X600-29N	U27	DIGI-KEY	MCP23017-E/ML-ND
17	1	GREEN LED_0603	LED5	DIGI-KEY	475-1409-2-ND
18	3	0.1UF 16V 10% 0402	C57-C59	DIGI-KEY	587-1451-2-ND
19	1	30MHZ OSC012	U25	DIGI-KEY	300-8257-1-ND
20	2	RED LED_0603	LED4,LED6	DIGI-KEY	475-2512-2-ND
21	3	YELLOW LED_0603	LED1-LED3	DIGI-KEY	475-2558-1-ND

ADSP-CM403F EZ-KIT Lite Bill Of Materials

Ref.	Qty	Description	Reference Designator	Manufacturer	Part Number
22	1	10UF 6.3V 20% 0402	C15	DIGI-KEY	445-8920-1-ND
23	1	STD2805T4 TO228P972X240-3N	Q1	DIGI-KEY	497-7465-1-ND
24	7	IDC 2PIN_JUMPER_ SHORT	SJ1-SJ7	DIGI-KEY	S9001-ND
25	1	PWR .65MM CON045	P7	DIGI-KEY	CP1-023-ND
26	1	1K 1/10W 5% 0603	R20	DIGI-KEY	311-1.0KGRTR-ND
27	1	4700PF 16V 10% 0603	C70	DIGI-KEY	311-1083-2-ND
28	2	100 1/16W 5% 0402	R95,R96	DIGI-KEY	311-100JRTR-ND
29	6	330.0 1/16W 1% 0402	R28,R77-R80, R91	DIGI-KEY	541-330LCT-ND
30	6	IDC 2X1 IDC2X1	JP1,JP2,P3-P6	FCI	90726-402HLF
31	2	IDC 3X1 IDC3X1	JP3,JP4	FCI	90726-403HLF
32	1	IDT74FCT3244APY SSOP20	U5	IDT	IDT74FCT3244APYG
33	1	TEST LOOP LOOP_ 2838	GP1	KEYSTONE	5016
34	3	0 1/4W 5% 1206	R15,R21,R13 8	KOA	0.0ECTRk7372BTTED
35	1	IDC 10X2 TE_ 5103308-5	P1	MOUSER	571-5103308-5
36	7	10UF 6.3V 20% 0603	C9,C10,C18, C24,C31,C32 ,C41	MULTICOMP	MCCA000517
37	1	190 100MHZ 5A FER002	FER3	MURATA	DLW5BSN191SQ2
38	1	DB9 9PIN CON038	J1	NORCOMP	191-009-213-L-571
39	1	GTL2002 TSSOP8	U24	NPX	GTL2002DP,118

Ref.	Qty	Description	Reference Designator	Manufacturer	Part Number
40	3	5A MBRS540T3G SMC	D4,D6,D7	ON SEMI	MBRS540T3G
41	3	MOMENTARY SWT024	SW2-SW4	PANASONIC	EVQ-Q2K03W
42	13	0 1/16W 5% 0402	R6,R7,R19,R 32,R37,R103, R108,R110,R 122,R131,R13 3,R135,R139	PANASONIC	ERJ-2GE0R00X
43	25	0 1/16W 5% 0402	R5,R18,R33, R36,R68,R10 5,R106,R111, R114-R119,R 121,R123,R12 7,R128,R132, R134,R136,R 137,R147-R1 49	PANASONIC	ERJ-2GE0R00X
44	3	1UF 6.3V 20% 0402	C17,C90,C91	PANASONIC	ECJ-0EB0J105M
45	7	10UF 10V 10% 0805	C12,C14,C20 ,C61,C62,C7 5,C78	PANASONIC	ECJ-2FB1A106K
46	2	27K 1/16W 5% 0402	R30,R31	PANASONIC	ERJ-2GEJ273X
47	2	60.4 1/10W 1% 0603	R67,R70	PANASONIC	ERJ-3EKF60R4V
48	1	45.3K 1/10W 1% 0402	R113	PANASONIC	ERJ-2RKF4532X
49	1	24.9 1/10W 1% 0402	R12	PANASONIC	ERJ-2RKF24R9X
50	1	10UF 10V 20% ELEC_ 4MM	CT1	PANASONIC	EEE-1AA100NR
51	26	PI3A125 SC70_5	U8-U21,U32- U38,U51-U55	PERICOM	PI3A125CEX
52	4	0.0 1/10W 1% 0603	R13,R14,R16, R17	PHYCOMP	232270296001L

ADSP-CM403F EZ-KIT Lite Bill Of Materials

Ref.	Qty	Description	Reference Designator	Manufacturer	Part Number
53	1	200.0K 1/16W 1% 0402	R142	ROHM	MCR01MZPF2003
54	1	IDC 5X2 IDC5x2_ SMT_F	J3	SAMTEC	SSW-105-22-F-D-VS
55	1	0.05 10X2 SAMTEC_ SHF-110-01-L-D-TH	P2	SAMTEC	SHF-110-01-L-D-TH
56	2	0.5MM 180PIN SAMTEC_QSH-090-F-D-A	J2,J7	SAMTEC	QSH-090-01-F-D-A
57	1	0.5MM 120PIN SAMTEC_QSH-060-F-D-A	J9	SAMTEC	QSH-060-01-F-D-A
58	3	0.051 OHM 1/2W 1% 1206	R38,R102,R109	SEI	CSF 1/2 0.05 1%R
59	2	600 100MHZ 500MA 1206	FER1,FER2	STEWART	HZ1206B601R-10
60	1	74LVC14A SOIC14	U3	TI	74LVC14AD
61	1	SN74LVC1G08 SOT23-5	U31	TI	SN74LVC1G08DBVE
62	2	SN74LVC1G08 SOT23-5	U29,U30	TI	SN74LVC1G08DBVE
63	1	RJ11 4PIN CON039	J8	TYCO	5558872-1
64	1	3A RESETTABLE FUS004	F1	TYCO	SMD300F-2
65	1	0 1/8W 5% 0805	R10	VISHAY	CRCW08050000Z0EA

Ref.	Qty	Description	Reference Designator	Manufacturer	Part Number
66	54	10K 1/16W 5% 0402	R1,R8,R11,R24-R27,R29,R35,R41-R43,R45,R46,R55-R61,R64-R66,R69,R73-R76,R81-R90,R92,R93,R97-R100,R104,R112,R124,R125,R143-R146,R224	VISHAY	CRCW040210K0FKED
67	9	10K 1/16W 5% 0402	R2-R4,R23,R39,R40,R44,R54,R126	VISHAY	CRCW040210K0FKED
68	1	4.7K 1/16W 5% 0402	R22	VISHAY	CRCW04024K70JNED
69	6	33 1/16W 5% 0402	R9,R62,R63,R94,R101,R120	VISHAY	CRCW040233R0JNEA
70	4	10 1/10W 5% 0603	R34,R71,R72,R107	VISHAY	CRCW060310R0JNEA
71	1	30A GSOT05 SOT23-3	D2	VISHAY	GSOT05-GS08
72	2	30A GSOT03 SOT23-3	D1,D3	VISHAY	GSOT03-GS08
73	6	22UF 16V 10% 1210	C45-C47,C96-C98	YAIYO YUDEN	EMK325BJ226KM-T

A

B

C

D

1

1

2

2

3

3

4

4

ADSP-CM403F EZ-KIT SCHEMATIC

		ANALOG DEVICES	20 Cotton Road Nashua, NH 03063 PH: 1-800-ANALOGD
Title		ADSP-CM403F EZ-KIT TITLE	
Size C	Board No.	A0342-2012	Rev 1.0
Date	08/27/2013	Sheet	1 of 10

A

B

C

D

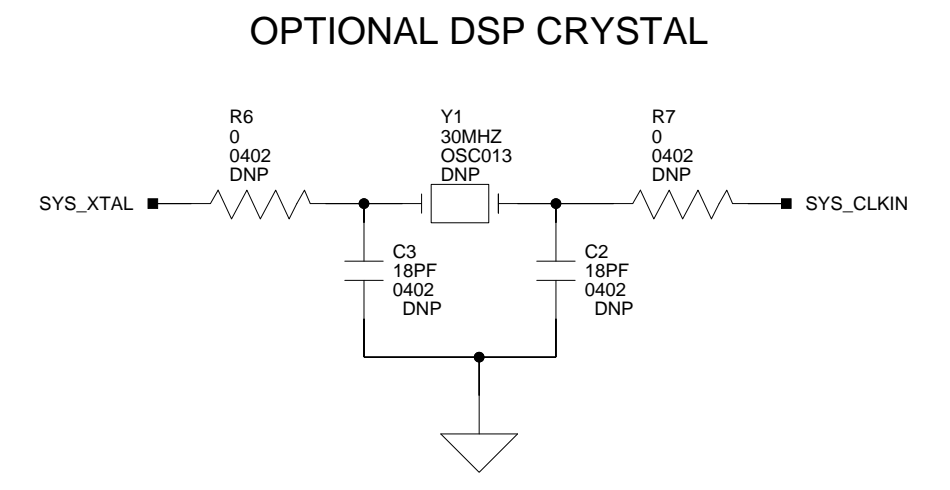
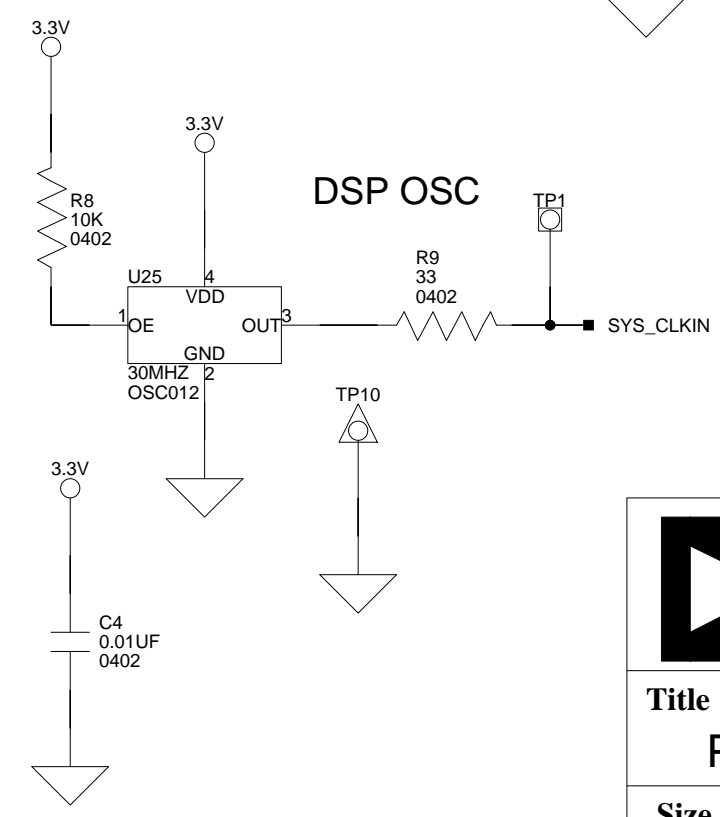
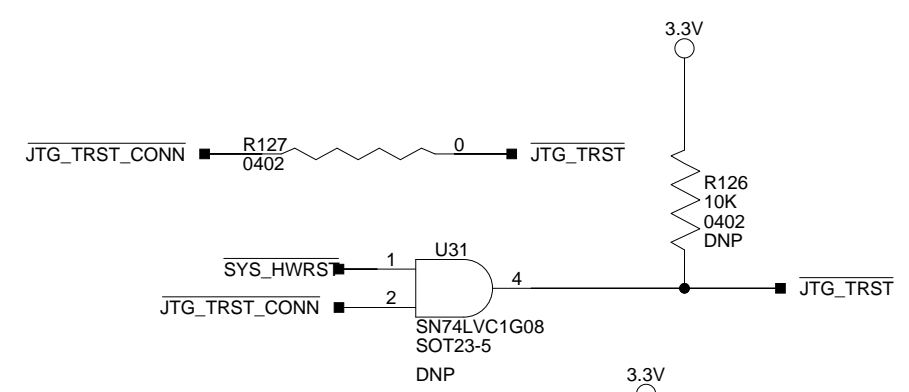
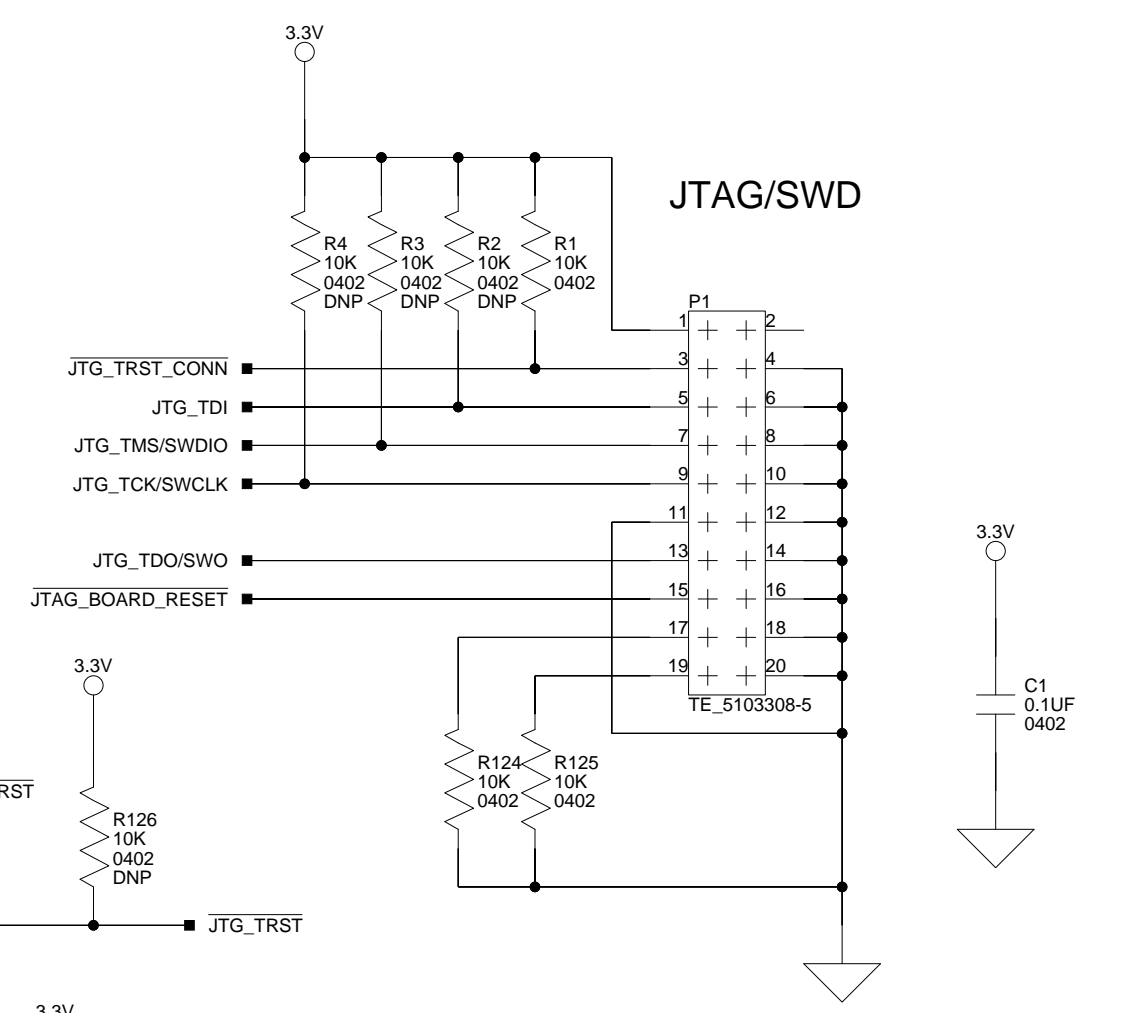
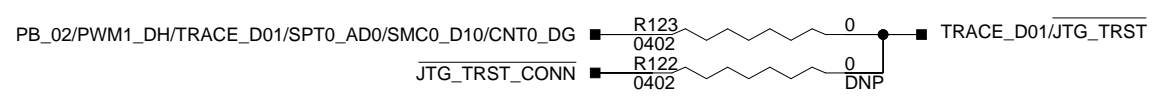
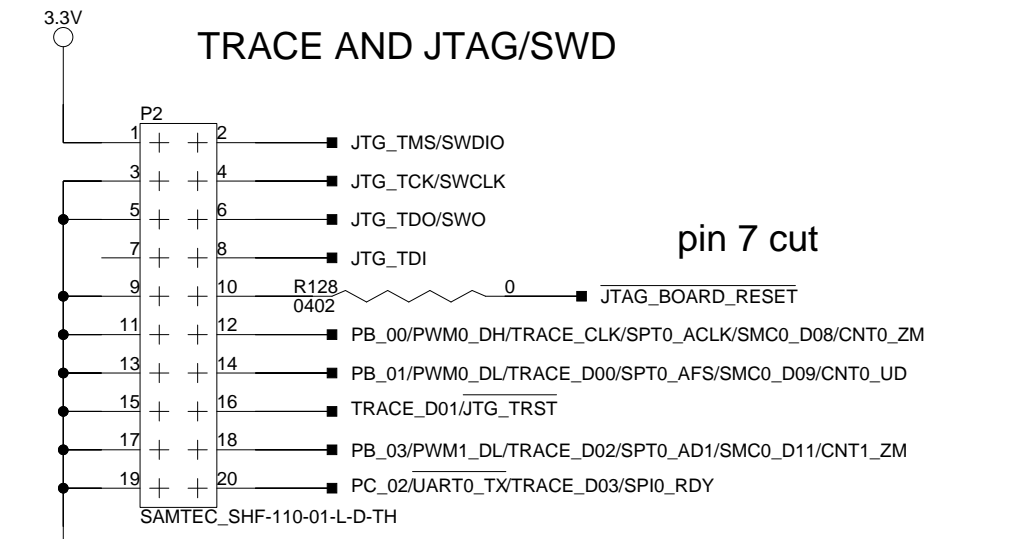
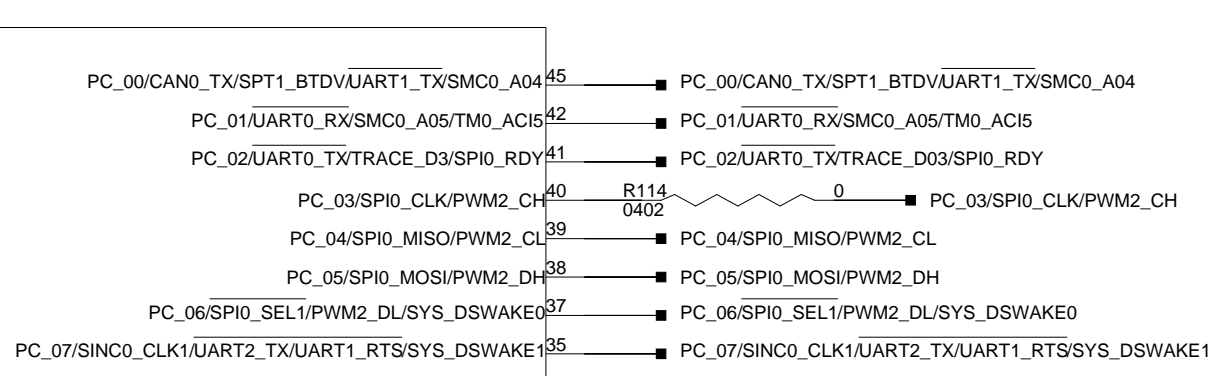
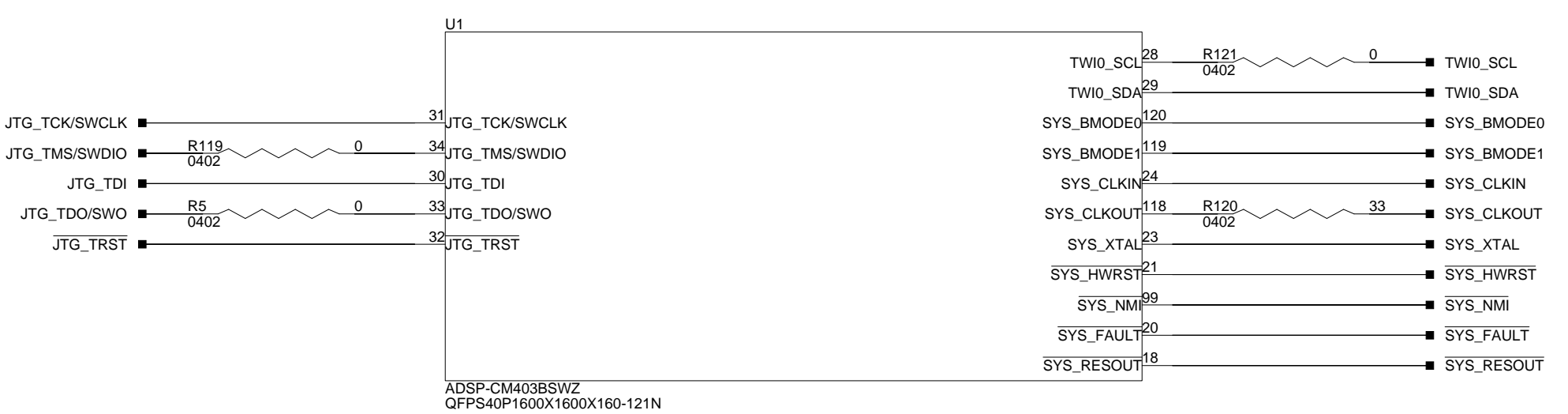
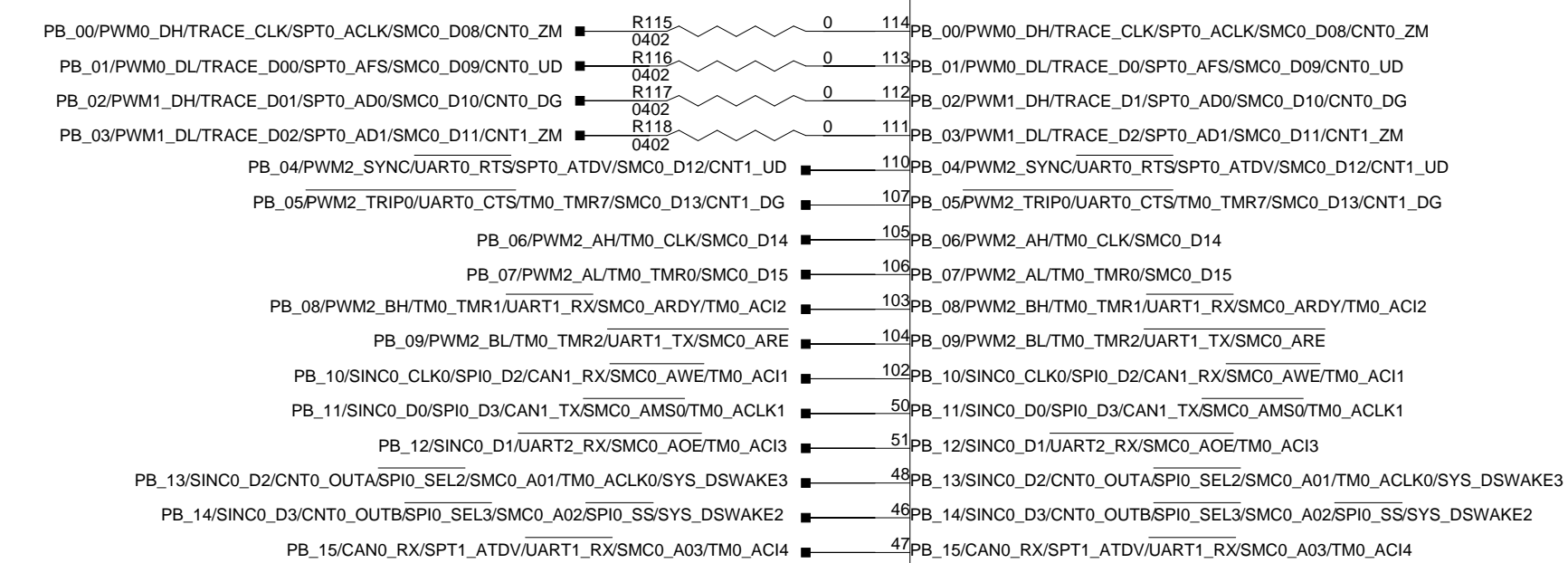
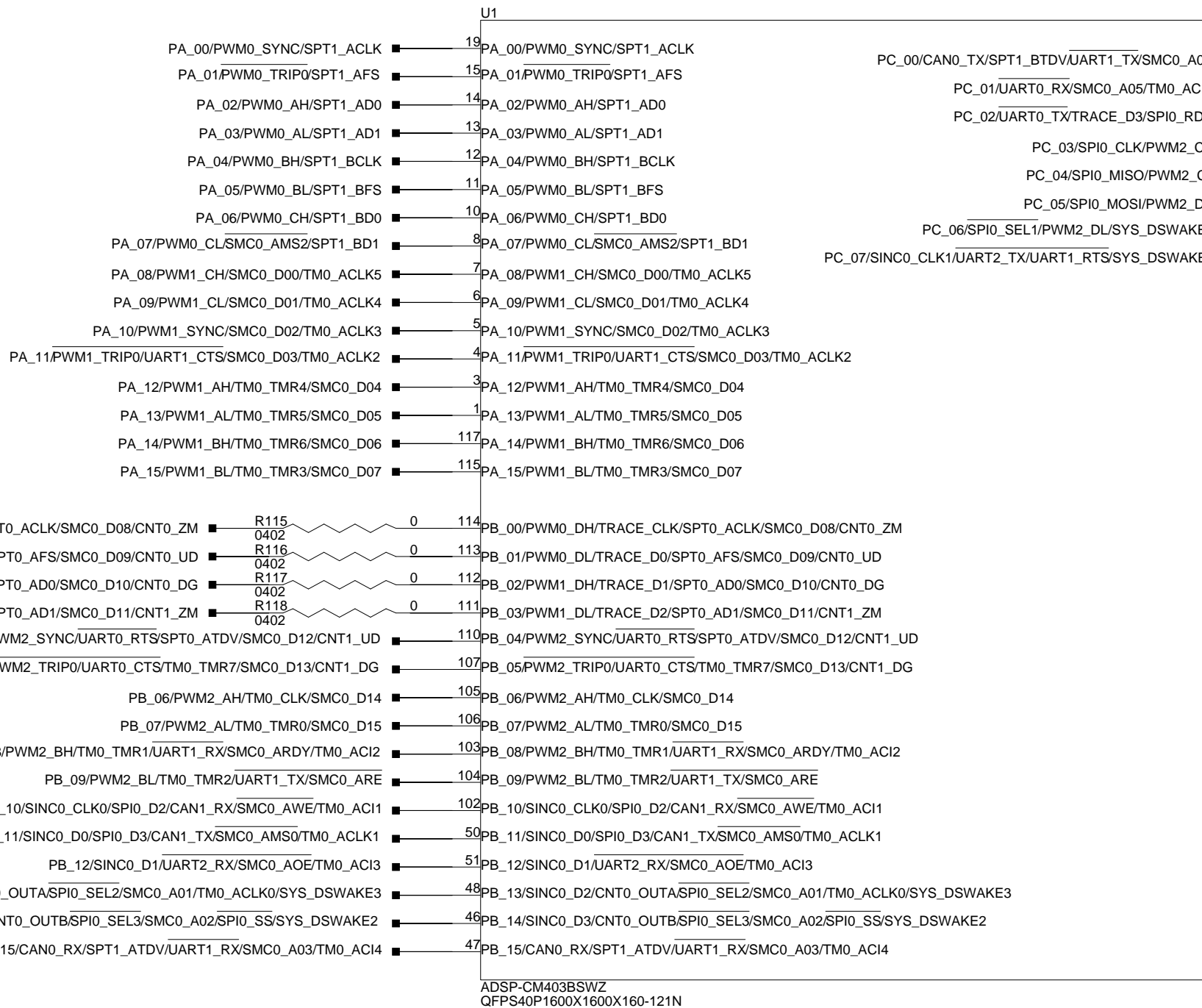

		20 Cotton Road Nashua, NH 03063 PH: 1-800-ANALOGD	
		Title ADSP-CM403F EZ-KIT PROC, JTAG/SWD AND TRACE CONN, CLOCK	
Size C	Board No.	A0342-2012	Rev
Date	08/27/2013	Sheet	2 of 10

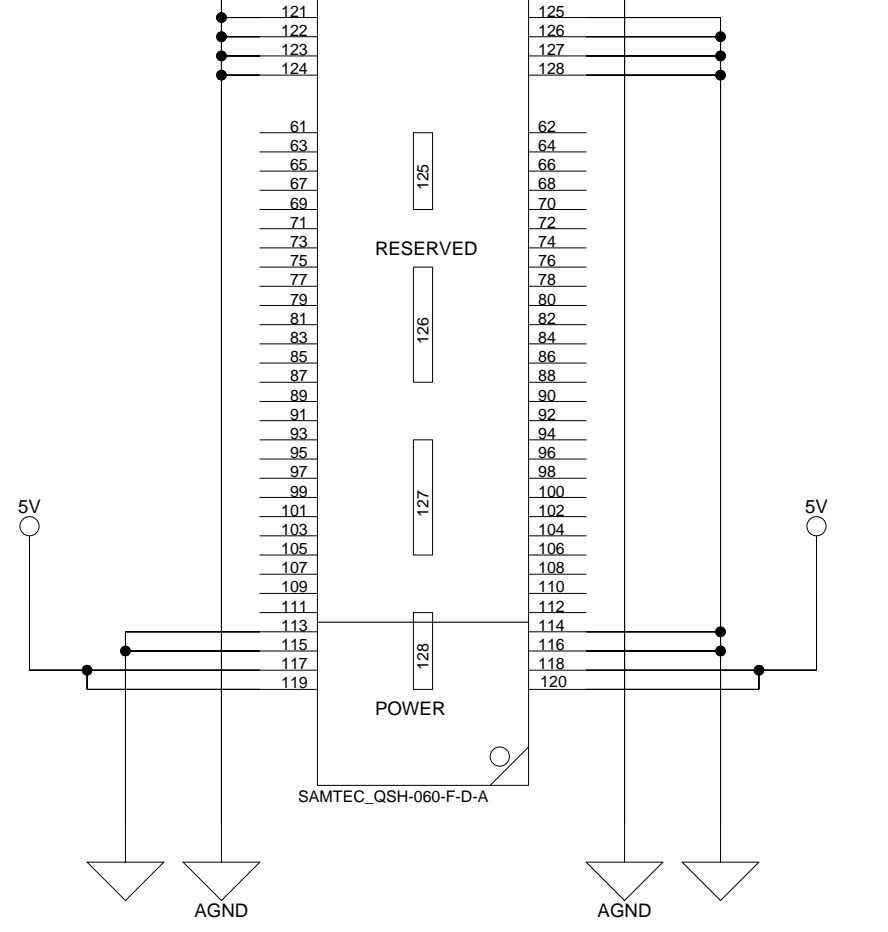
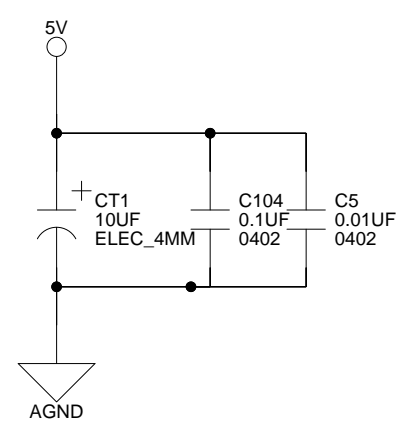
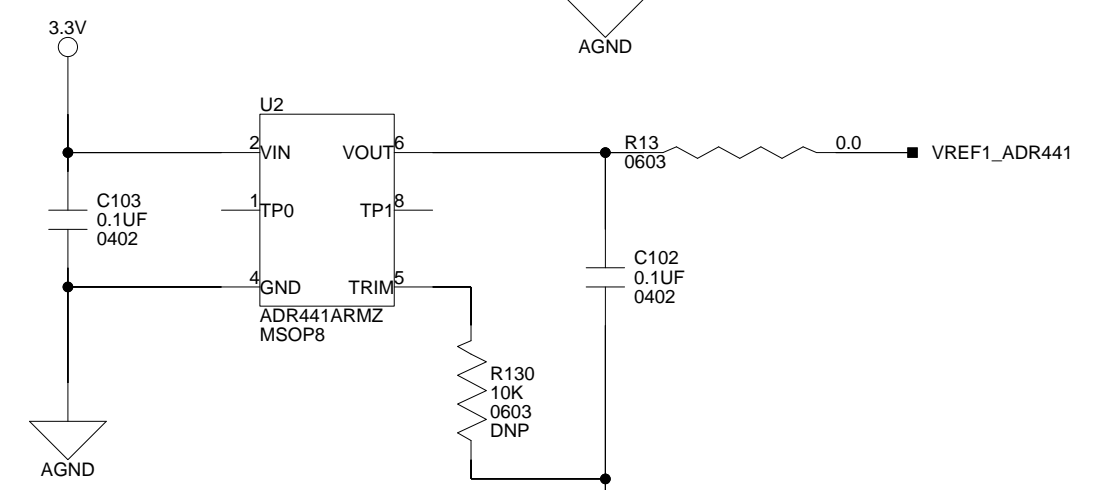
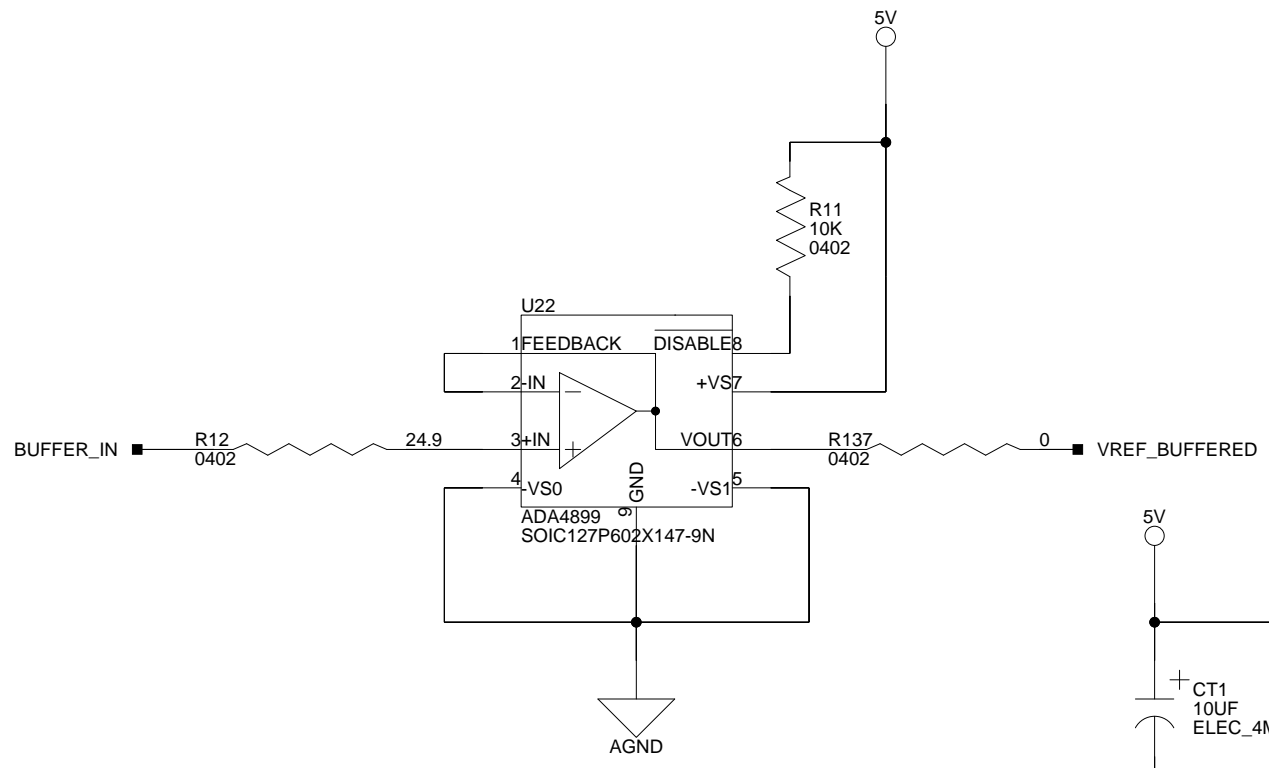
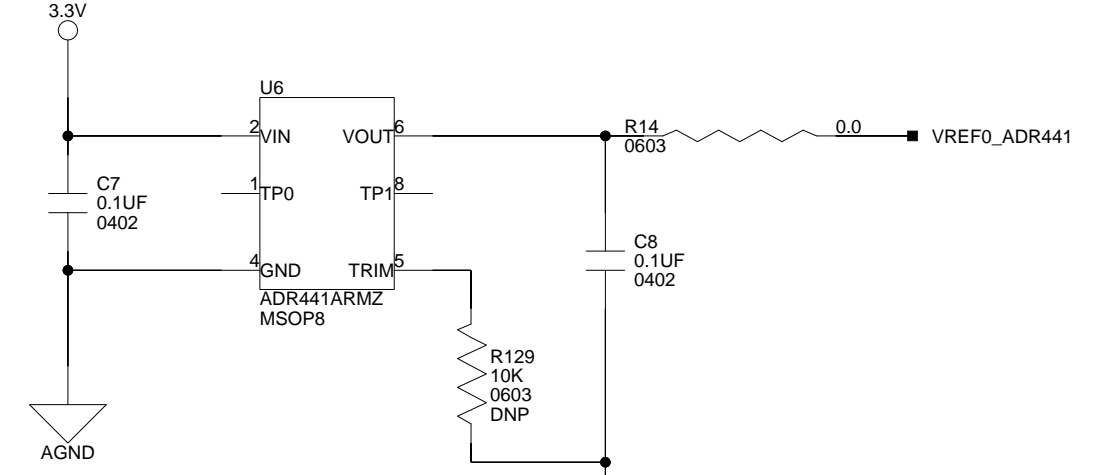
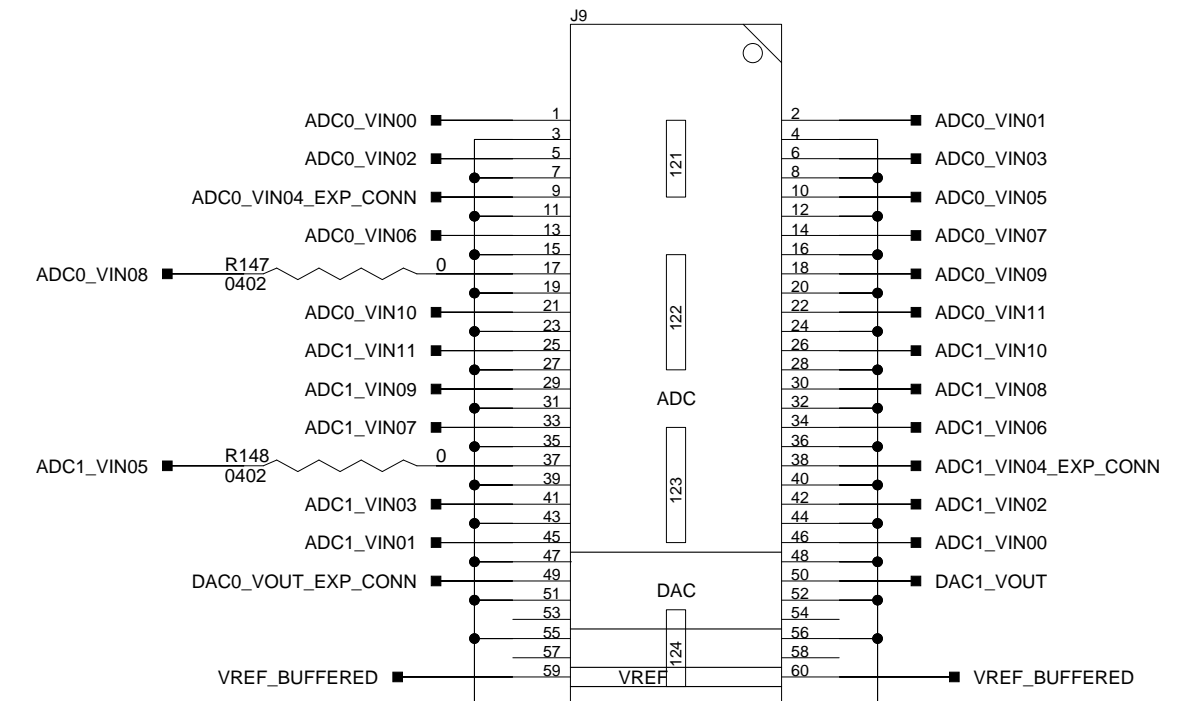
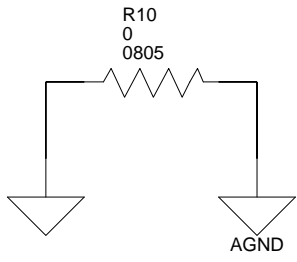
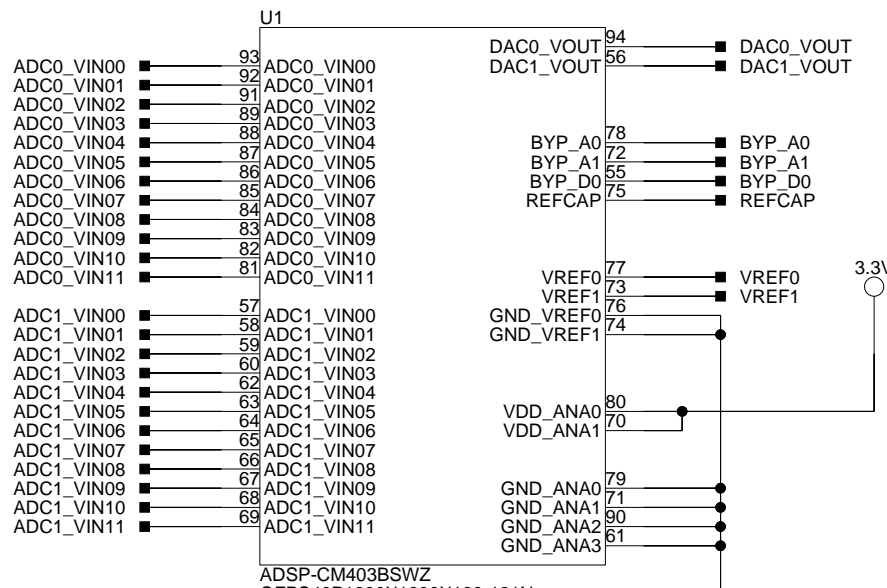

ANALOG CONN

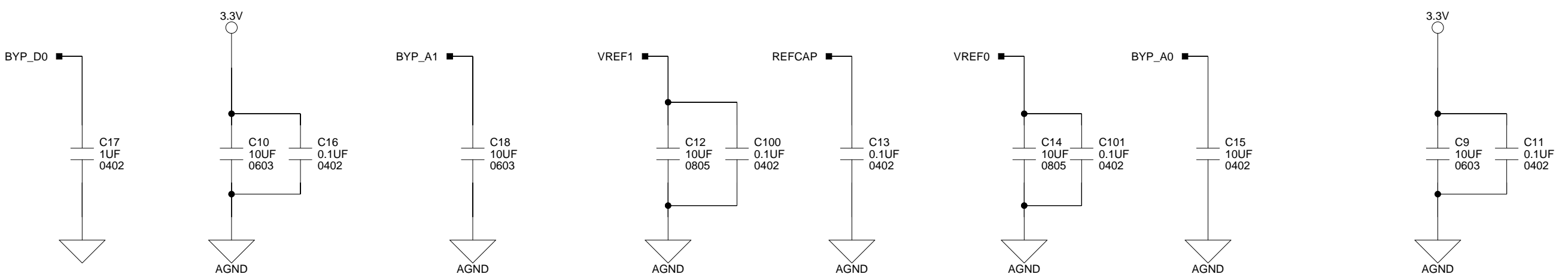
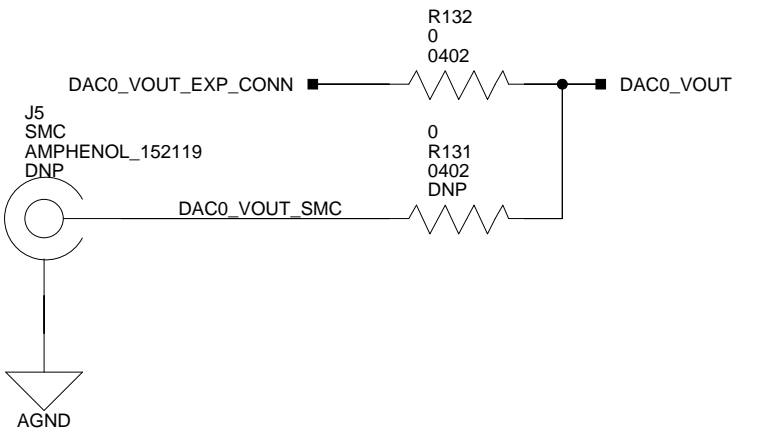
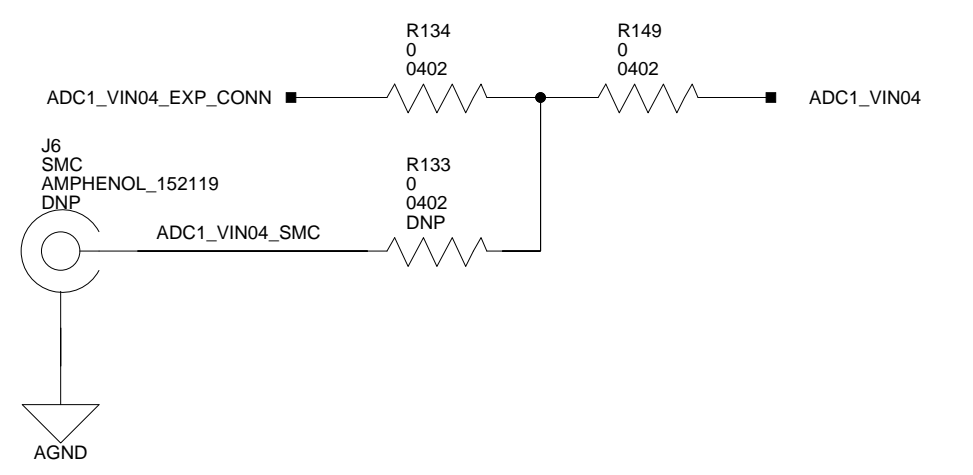
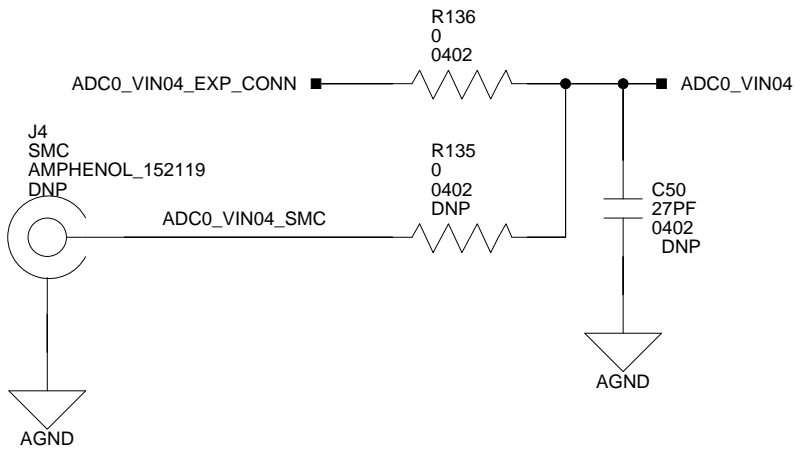
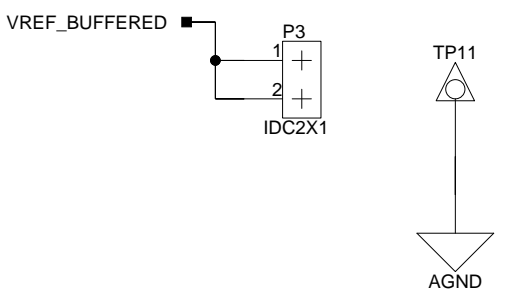
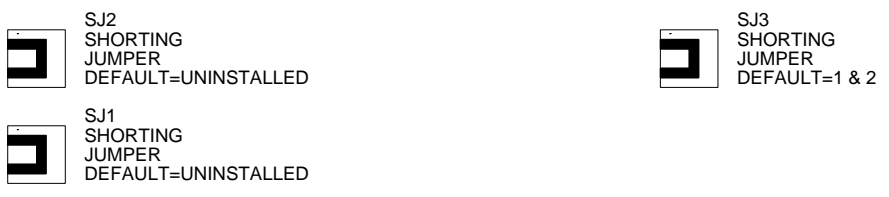
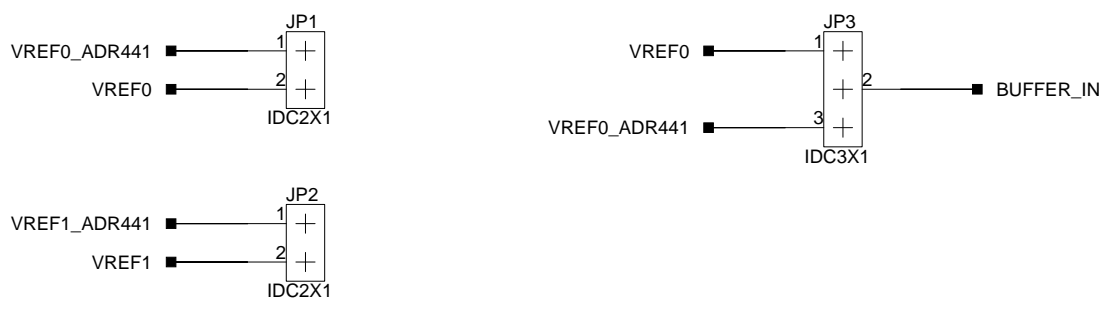

Pins 55-Center pad Pins 80-79 Pins 72-71 Pins 73-74 Pins 75-74 Pins 77-76 Pins 78-79 Pins 70-71

20 Cotton Road
Nashua, NH 03063
PH: 1-800-ANALOGD

Title		ADSP-CM403F EZ-KIT ANALOG CONN, POWER	
Size C	Board No.	A0342-2012	
Date	08/27/2013	Sheet	3 of 10
		Rev 1.0	

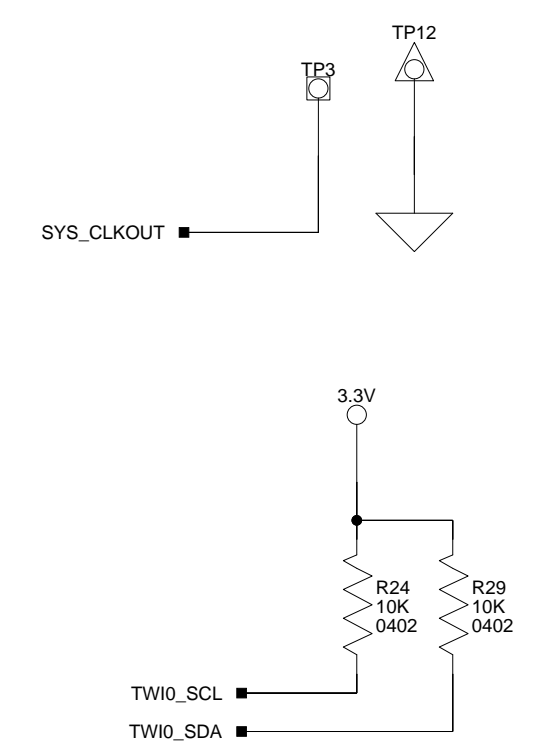
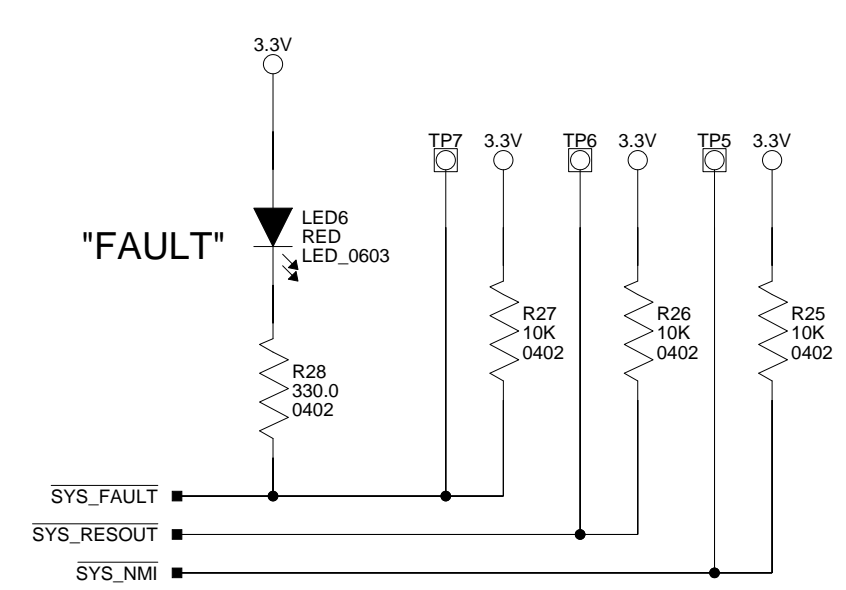
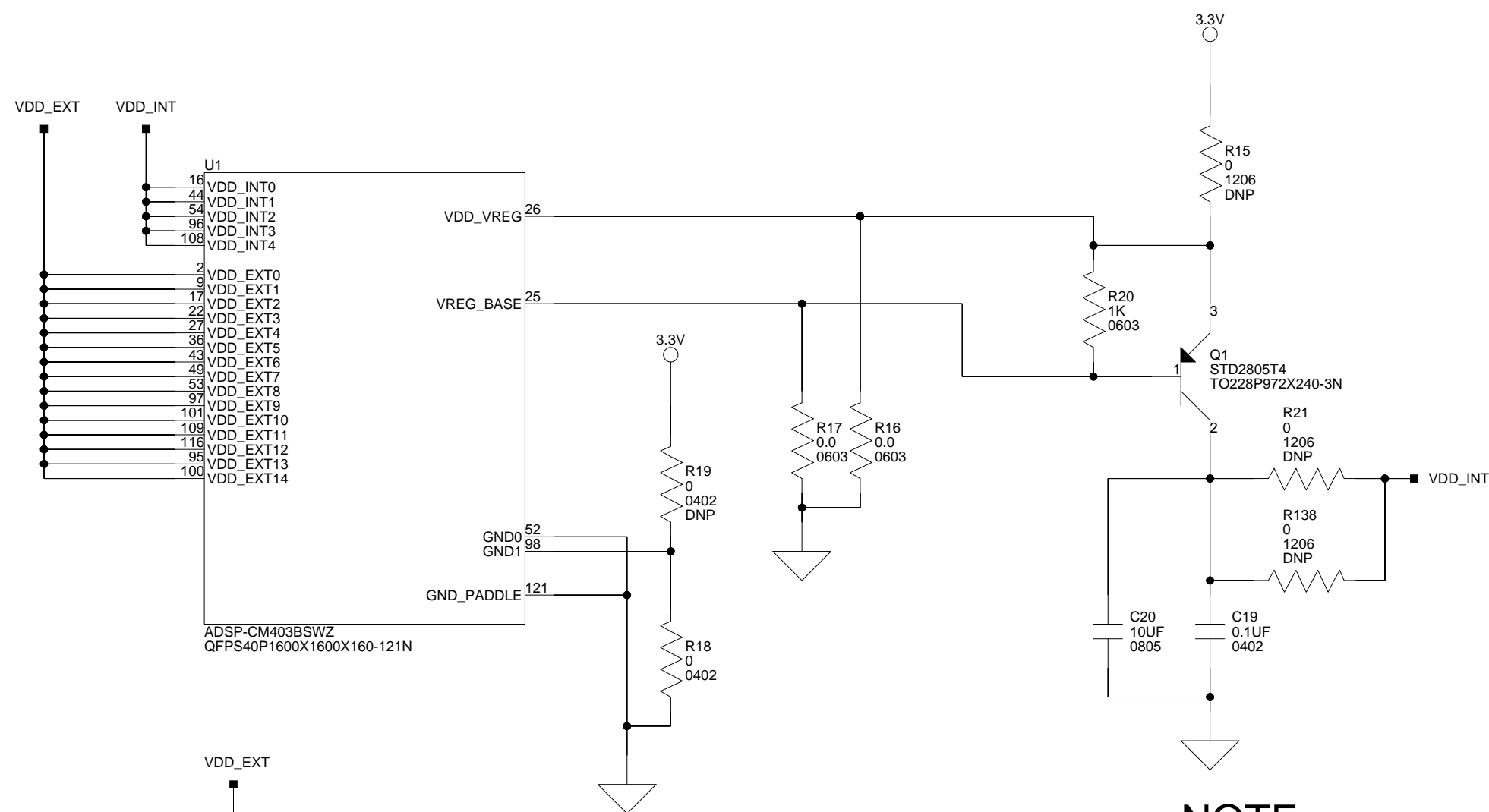

NOTE:

INTERNAL REGULATOR REMOVE R17, R16, P4, R38, R33 INSTALL R21, R15, R32
EXTERNAL REGULATOR REMOVE R21, R15, R32 INSTALL R17, R16, P4, R38, R33

NOTE: CONNECT PIN 98 DIRECTLY TO GROUND FOR CUSTOMER DESIGNS

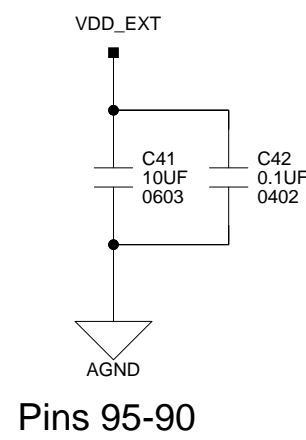

S_{J4} SHORTING JUMPER
DEFAULT=INSTALLED

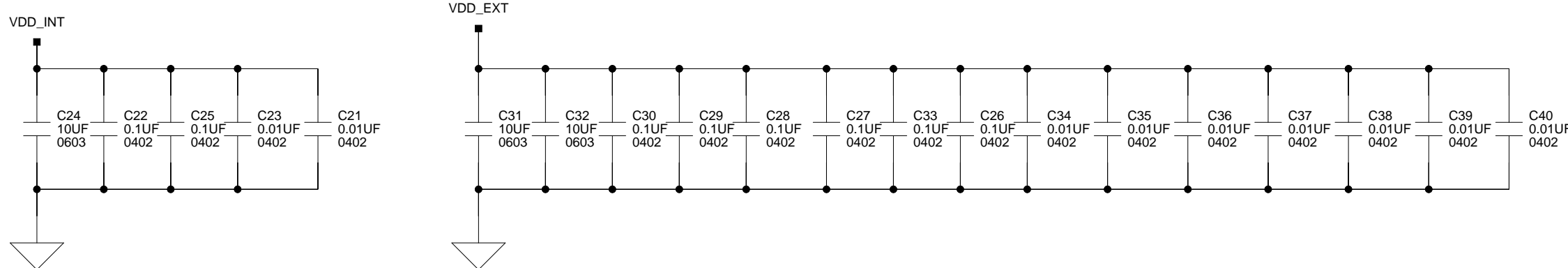
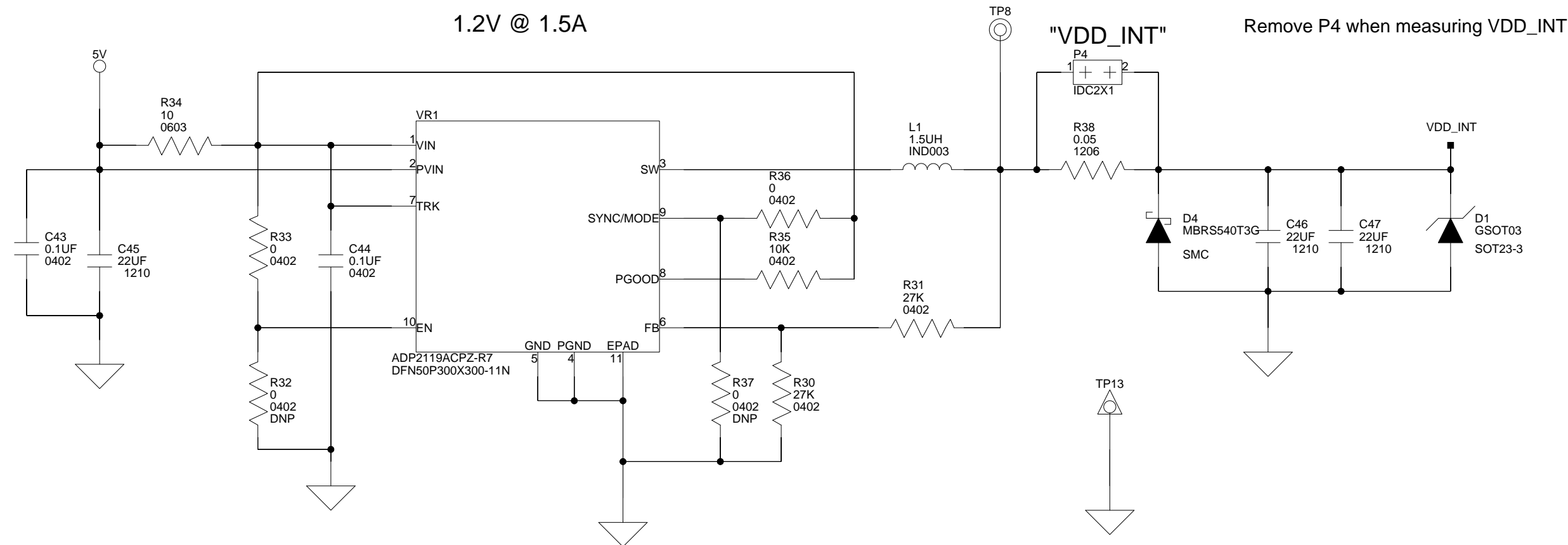

		20 Cotton Road Nashua, NH 03063 PH: 1-800-ANALOGD
Title: ADSP-CM403F EZ-KIT DIGITAL POWER, VDD_INT		
Size C	Board No. A0342-2012	Rev 1.0
Date	08/27/2013	Sheet 4 of 10

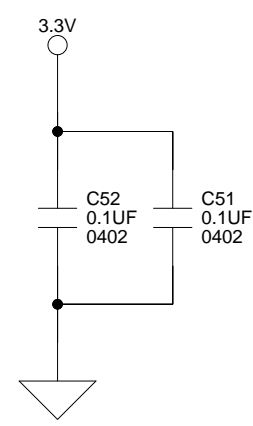
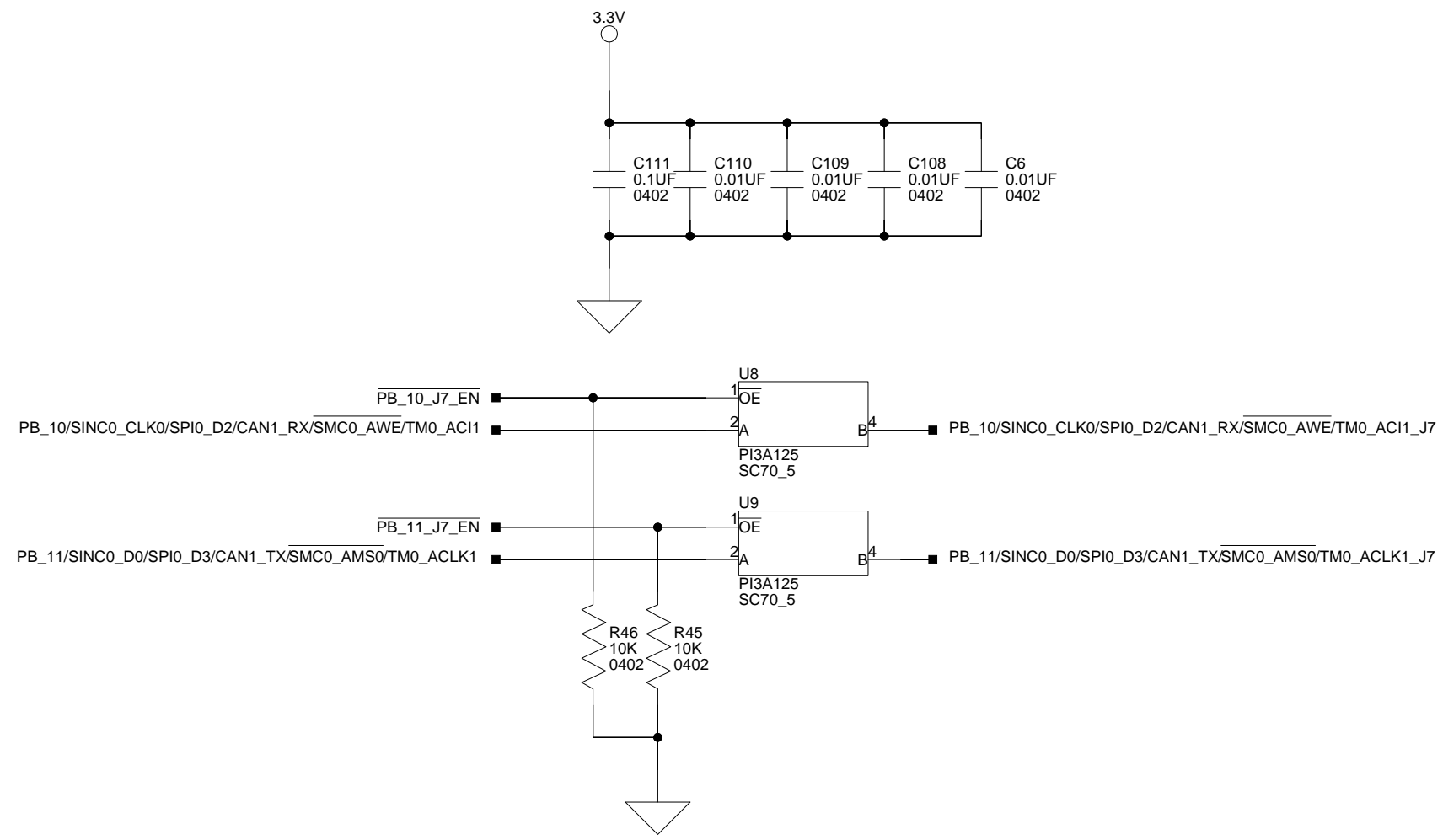
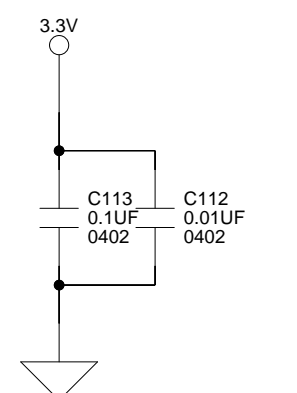
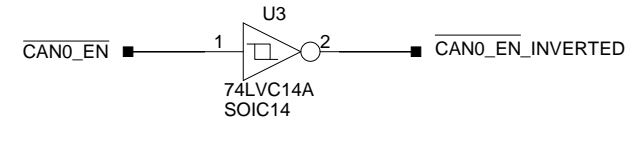
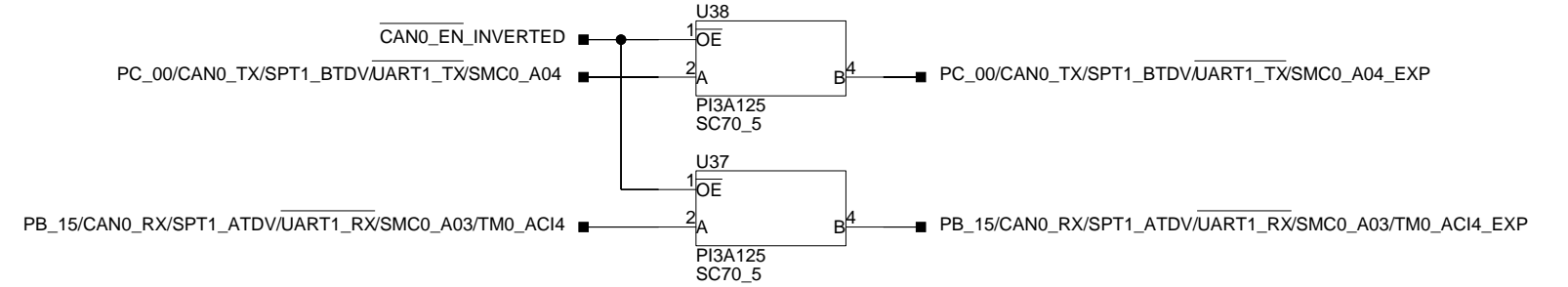
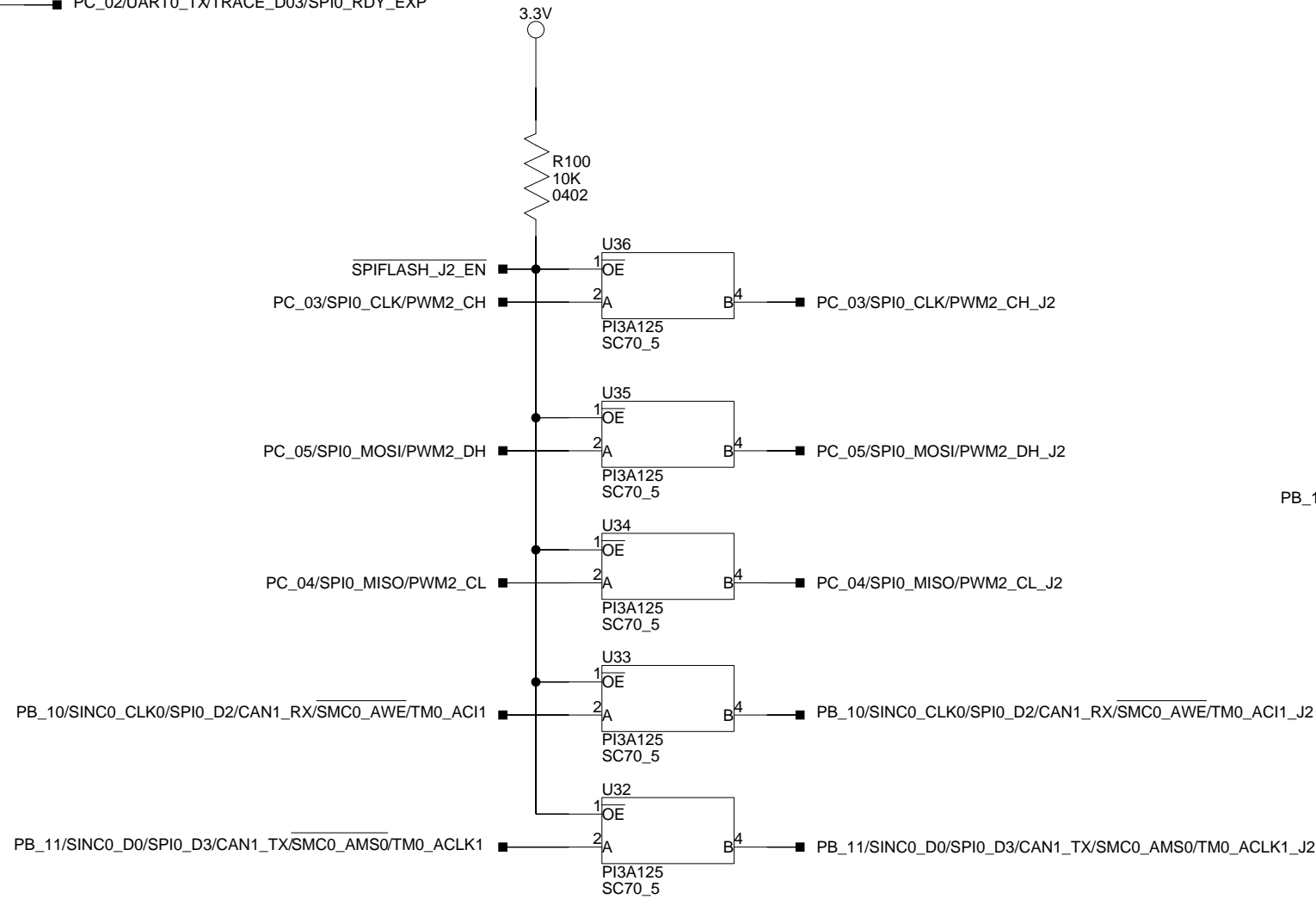
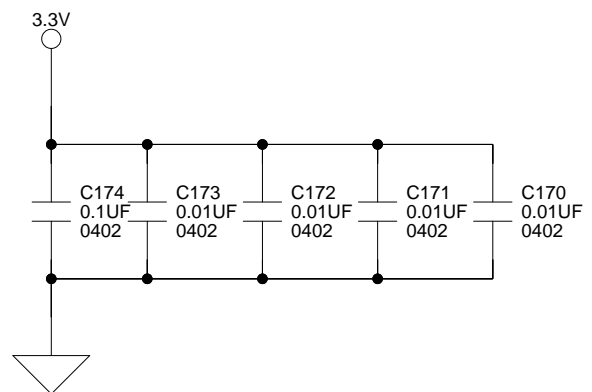
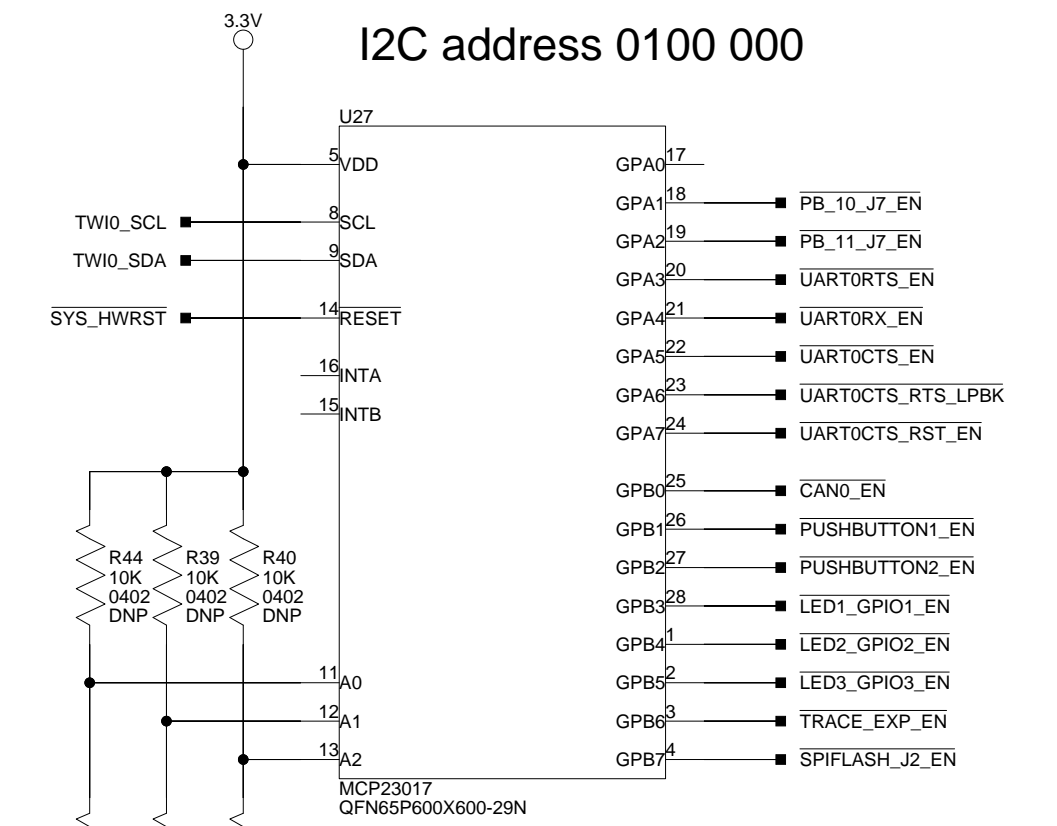
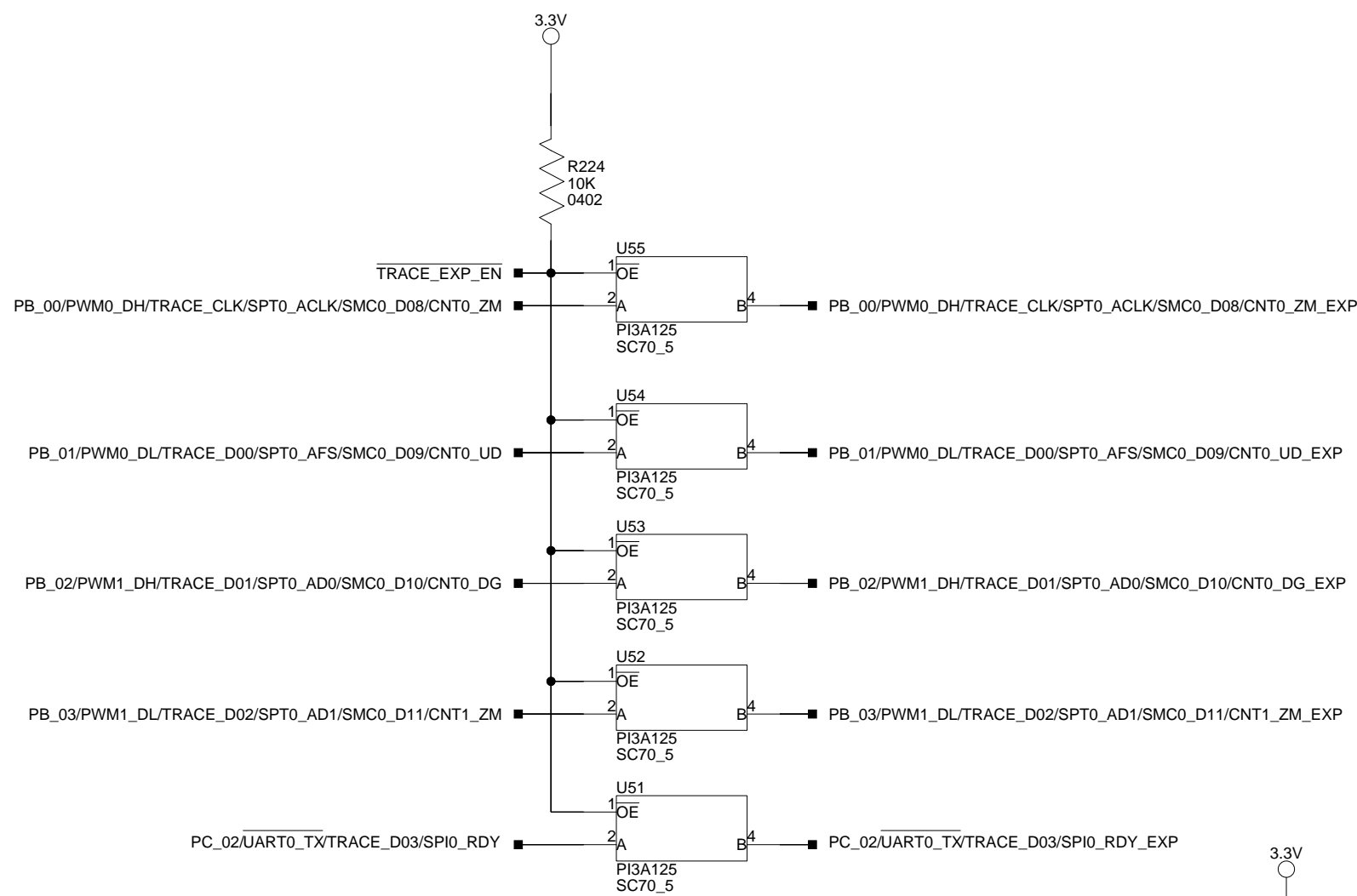

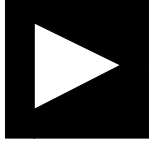
 ANALOG DEVICES		20 Cotton Road Nashua, NH 03063 PH: 1-800-ANALOGD	
		Title ADSP-CM403F EZ-KIT MEMORY AND SOFTCONFIG	
Size C	Board No. A0342-2012	Rev 1.0	
Date 08/27/2013	Sheet 5 of 10		

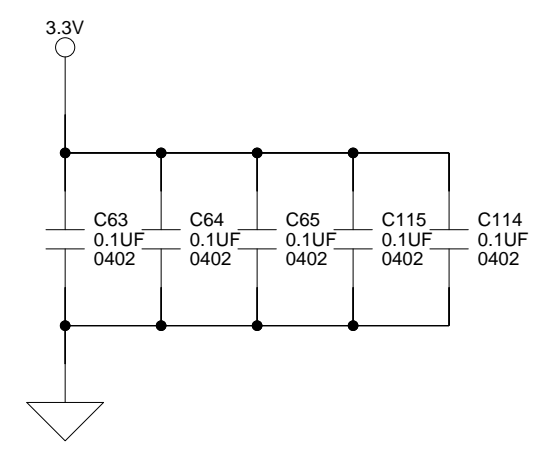
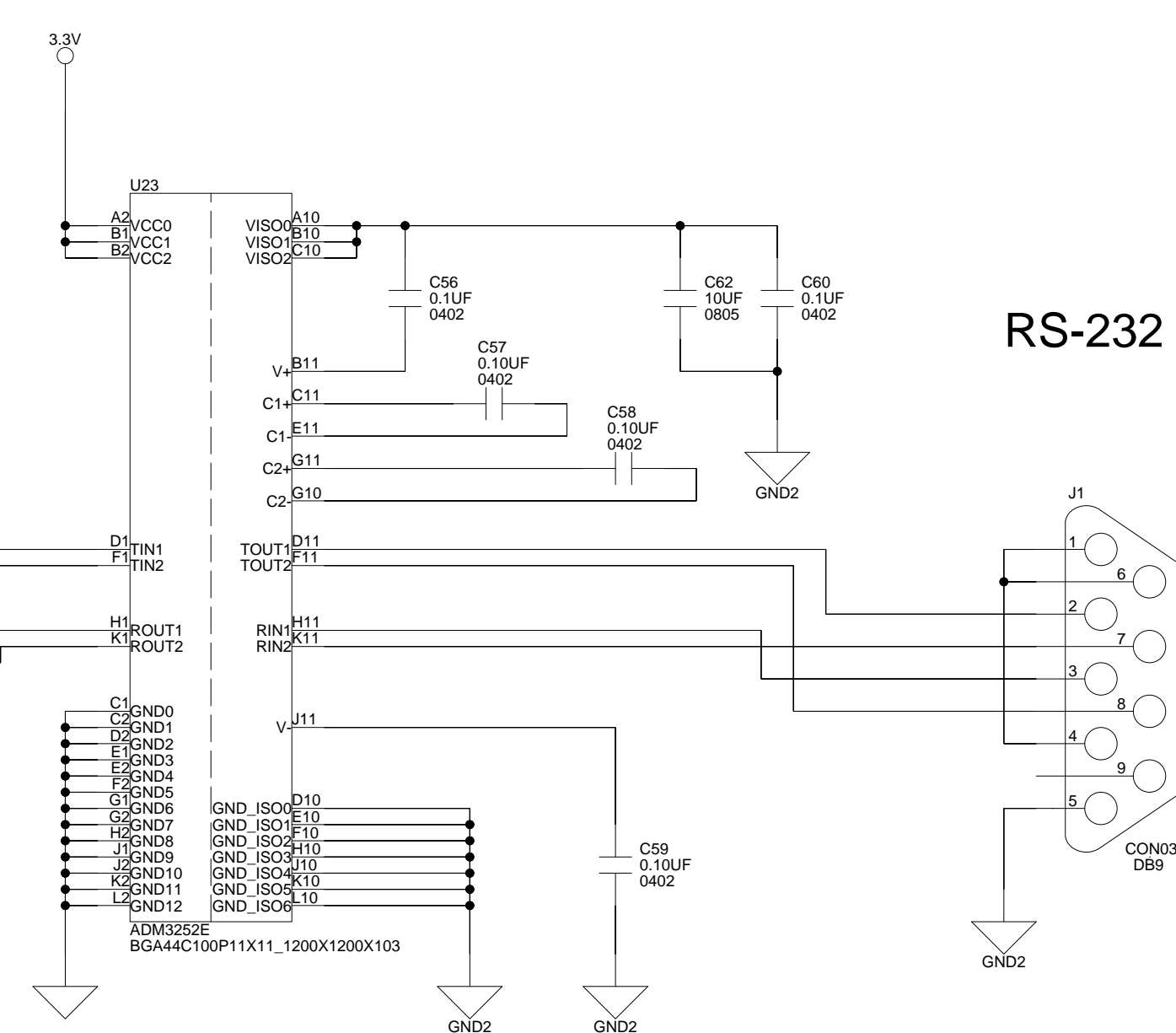
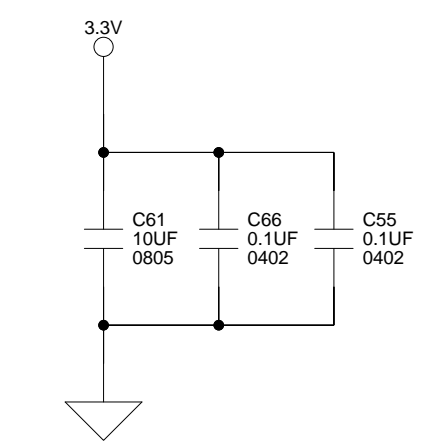
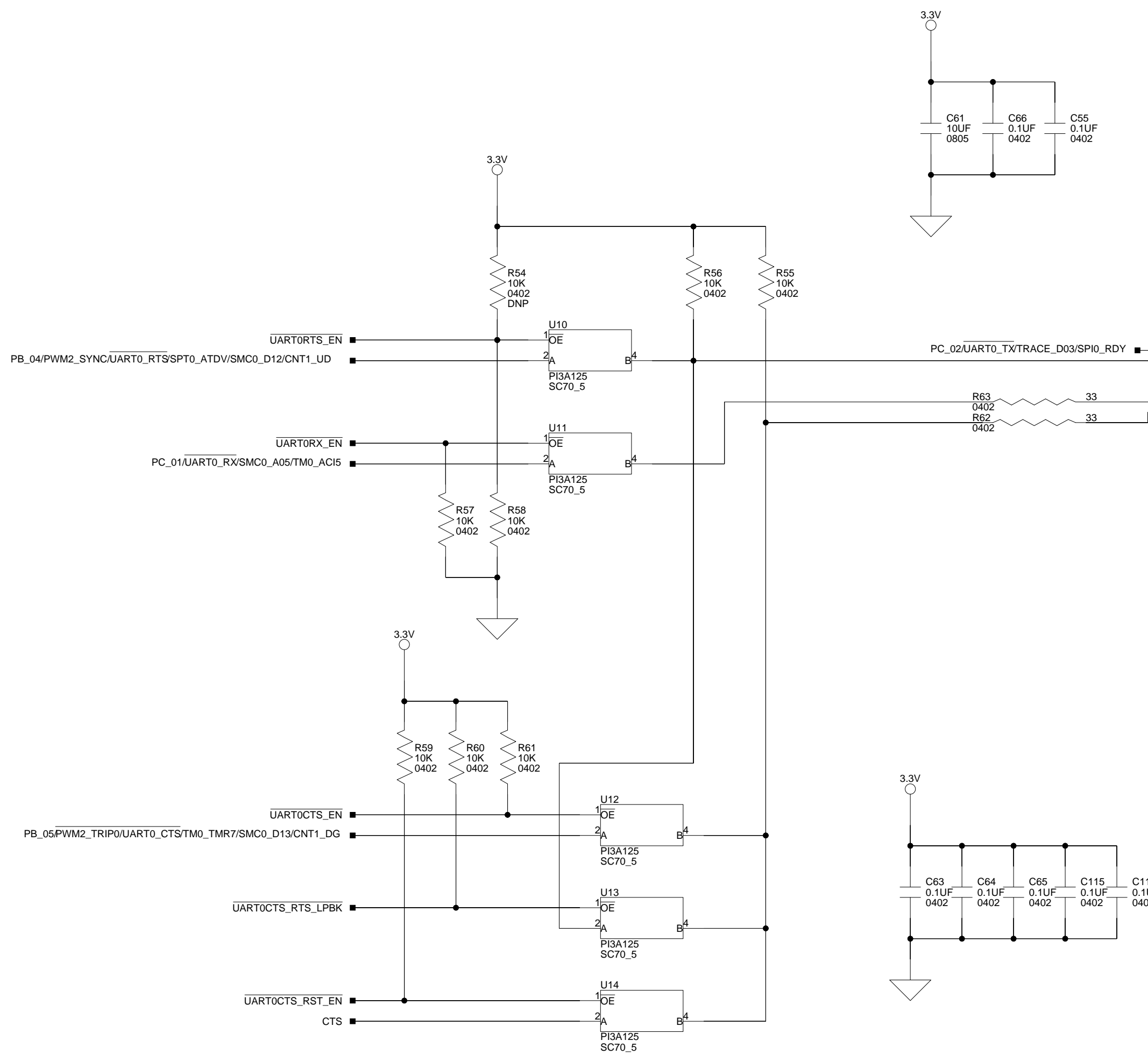

BOOT MODE SWITCH (SW1)

Bootmode (1:0)	
00	No Boot
01	SPI Master Boot (internal SPI2)
10	SPI Slave Boot (SPI0)
11	UART Boot (UART0)

Default

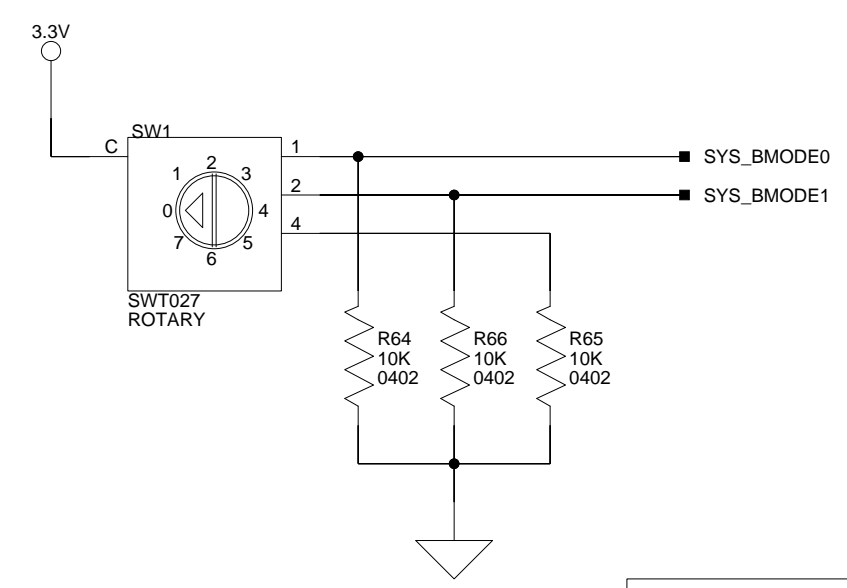

ANALOG DEVICES

20 Cotton Road
Nashua, NH 03063
PH: 1-800-ANALOGD

Title		ADSP-CM403F EZ-KIT RS-232, BOOT CONN	
Size C	Board No.	A0342-2012	Rev 1.0
Date	08/27/2013	Sheet	6 of 10

A

B

C

D

1

1

2

2

3

3

4

4

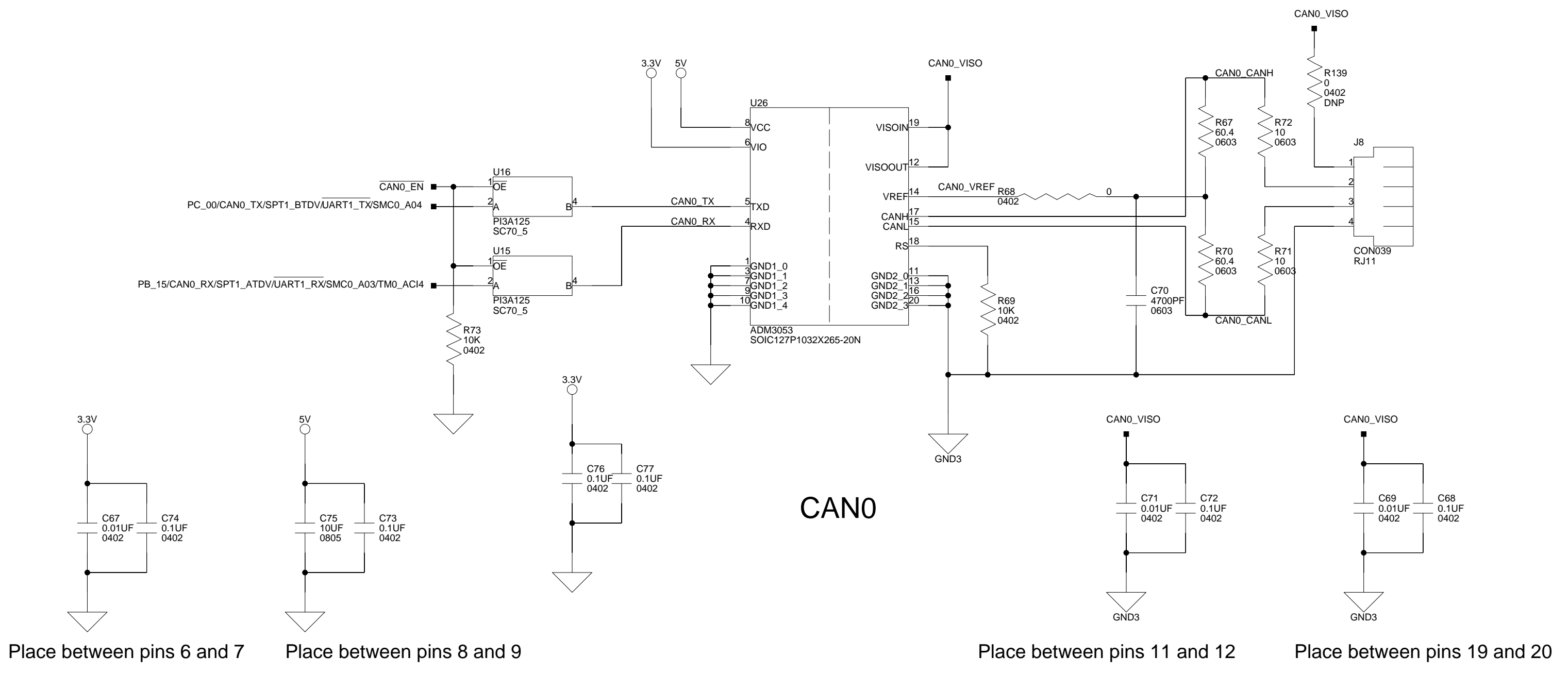

20 X 2 Character Display

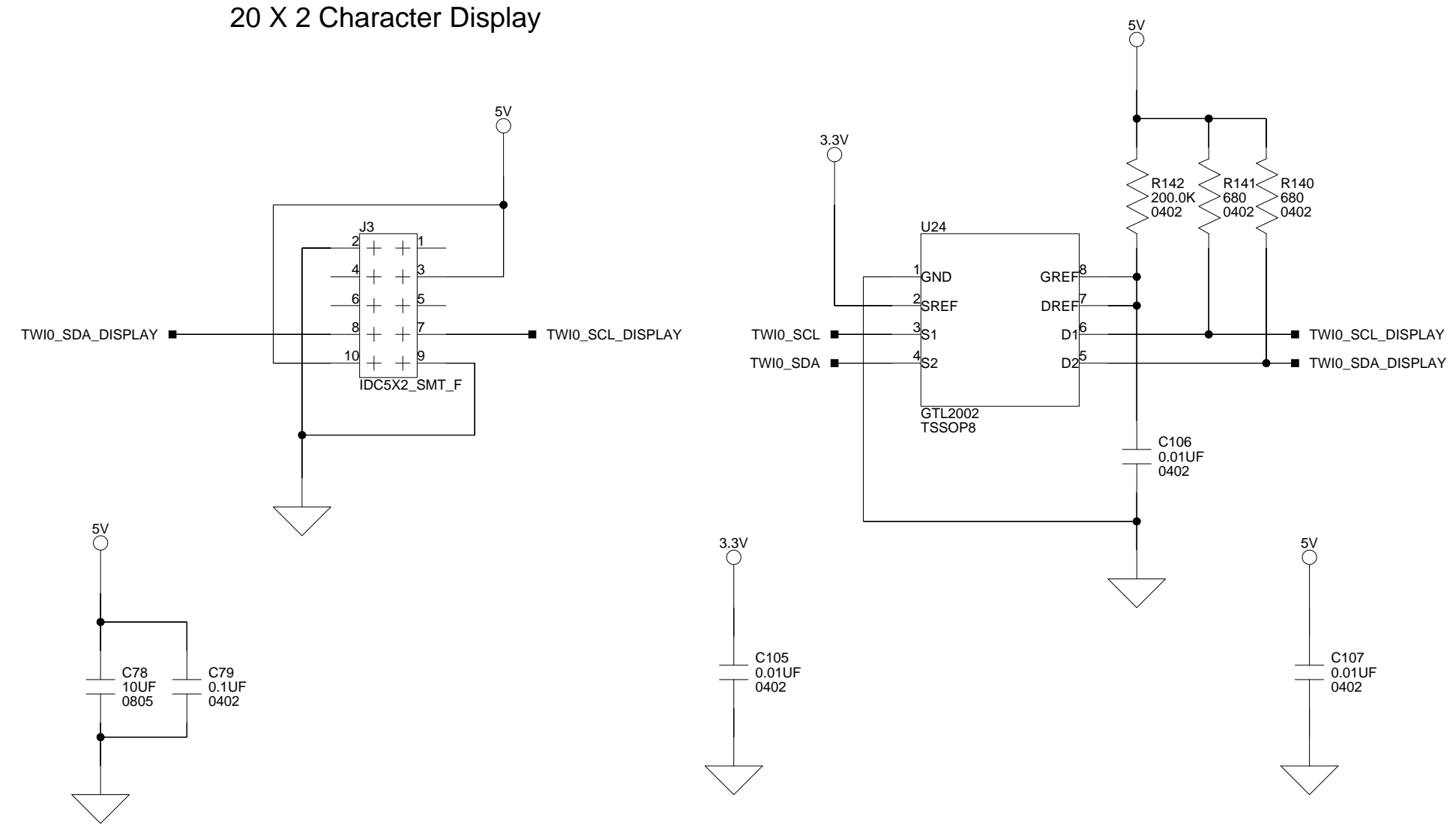

 ANALOG DEVICES		20 Cotton Road Nashua, NH 03063 PH: 1-800-ANALOGD	
		Title ADSP-CM403F EZ-KIT CAN0, DISPLAY	
Size C	Board No. A0342-2012	Rev 1.0	
Date 08/27/2013	Sheet 7 of 10		

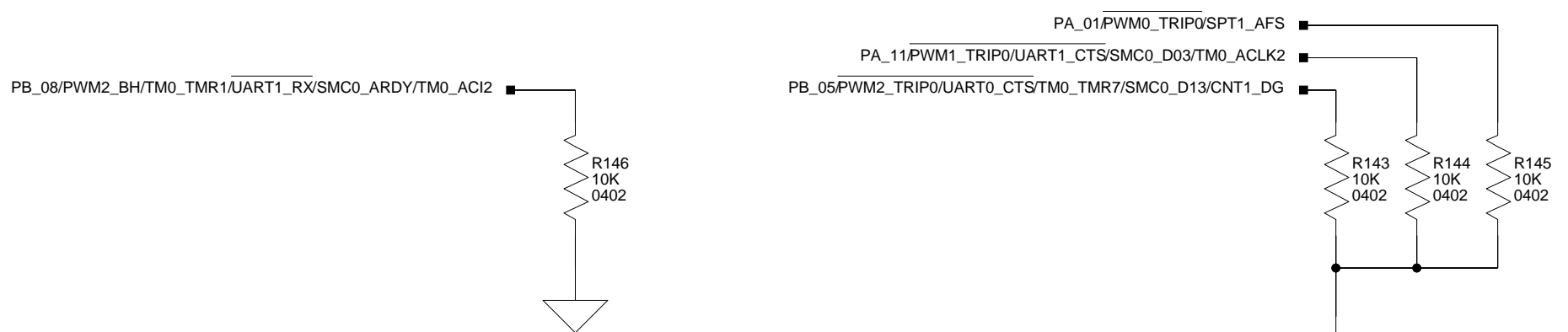
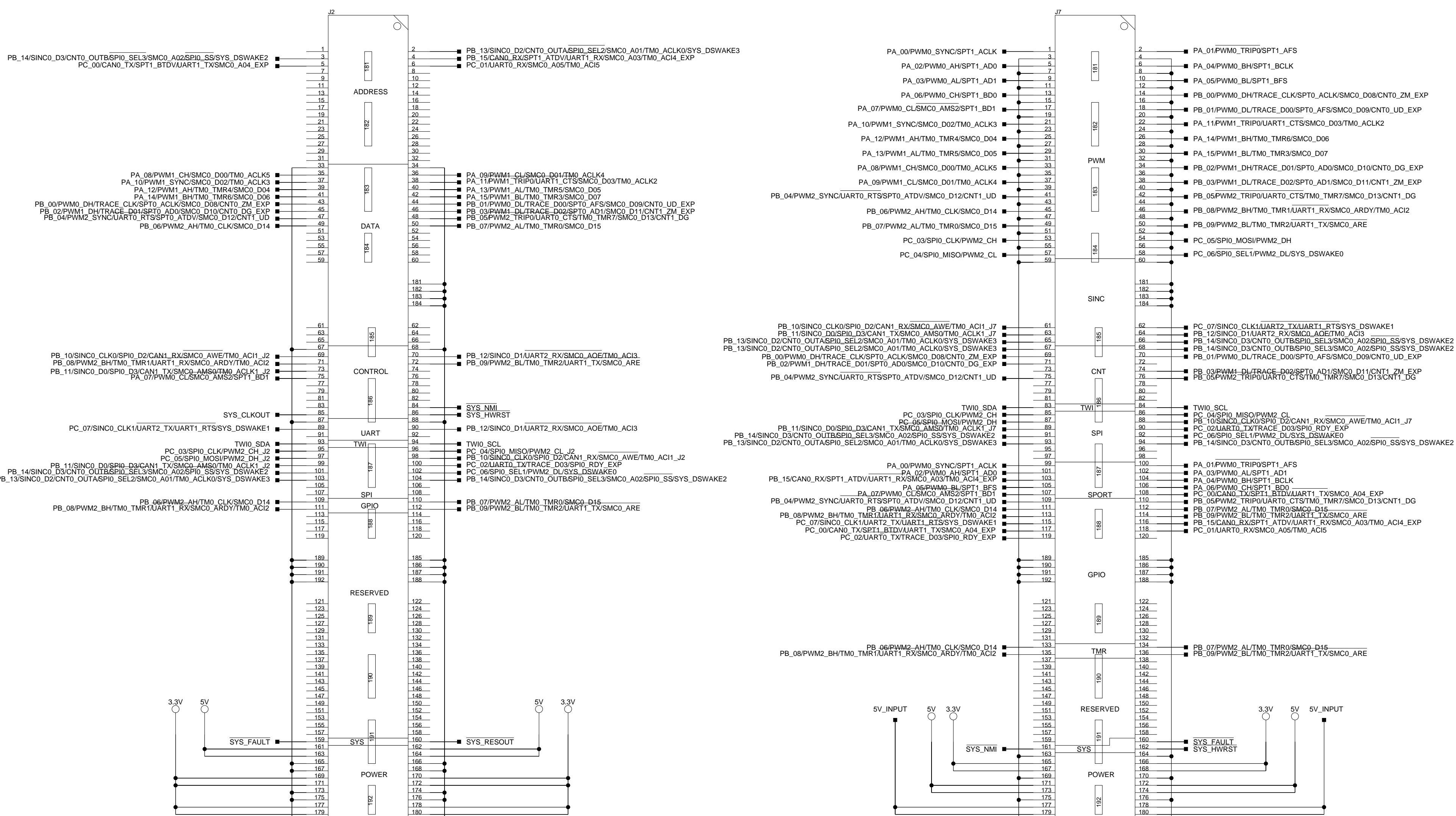

20 Cotton Road
Nashua, NH 03063
PH: 1-800-ANALOGD

Title			ADSP-CM403F EZ-KIT EXPANSION CONNECTORS
Size C	Board No.	A0342-2012	
Date		08/27/2013	Sheet 8 of 10
Rev		1.0	

A

B

C

D

1

1

2

2

3

3

4

4

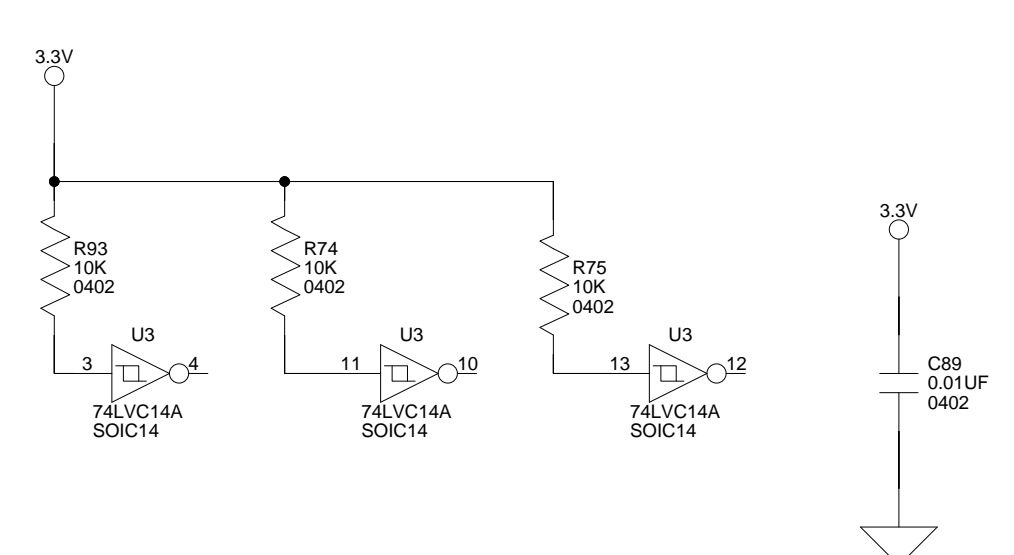
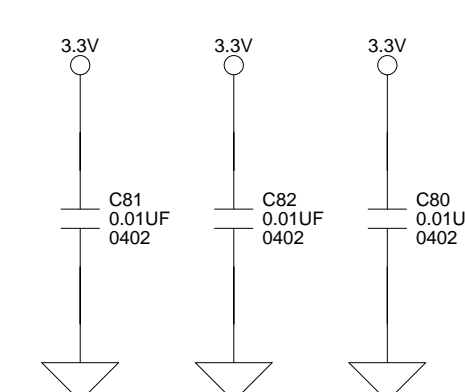
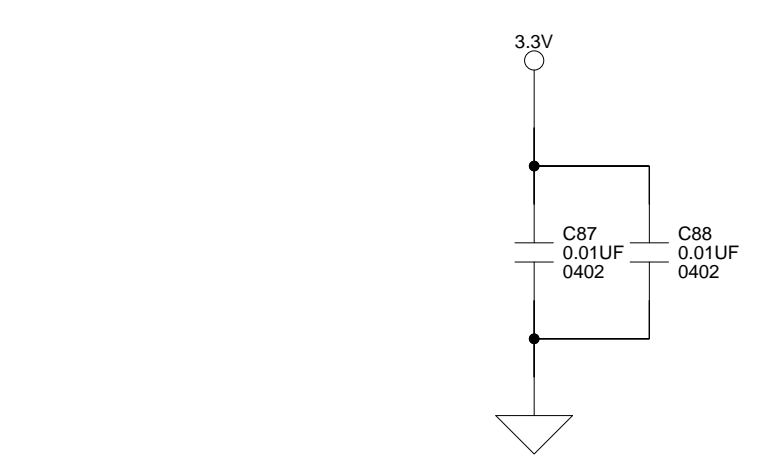
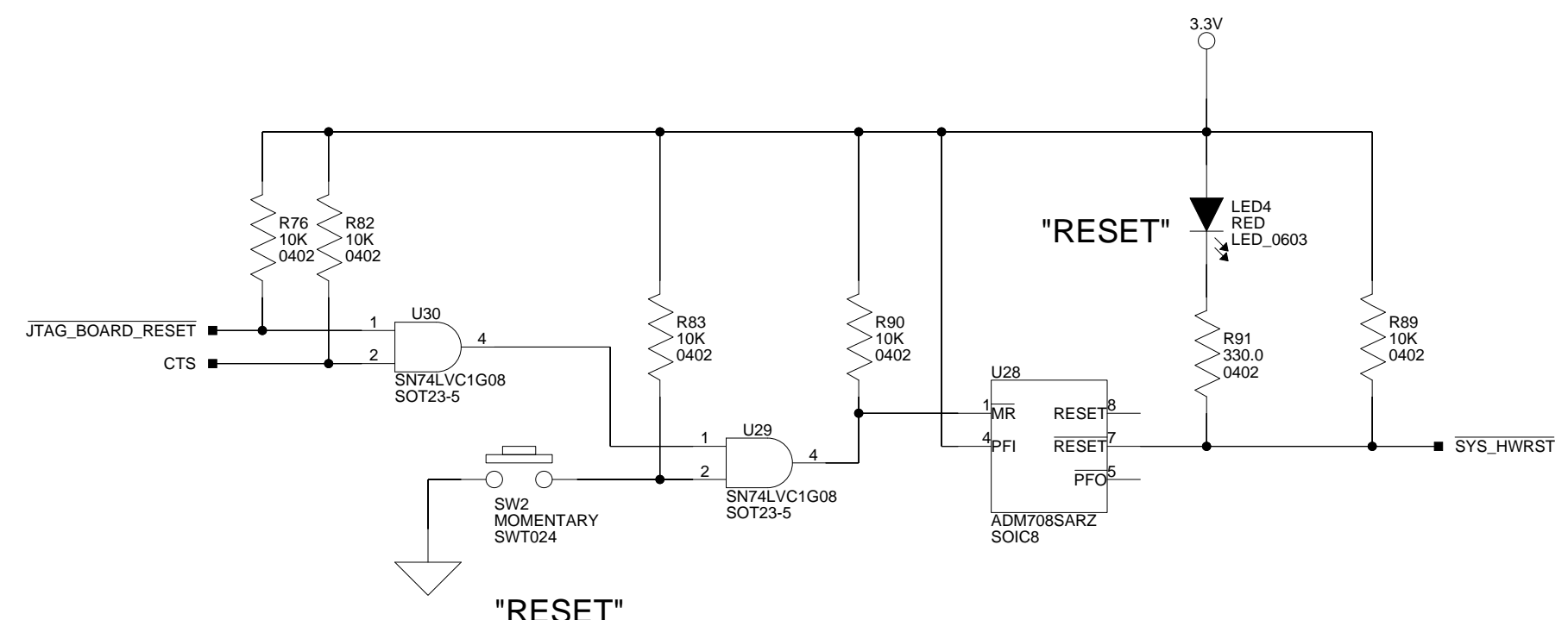
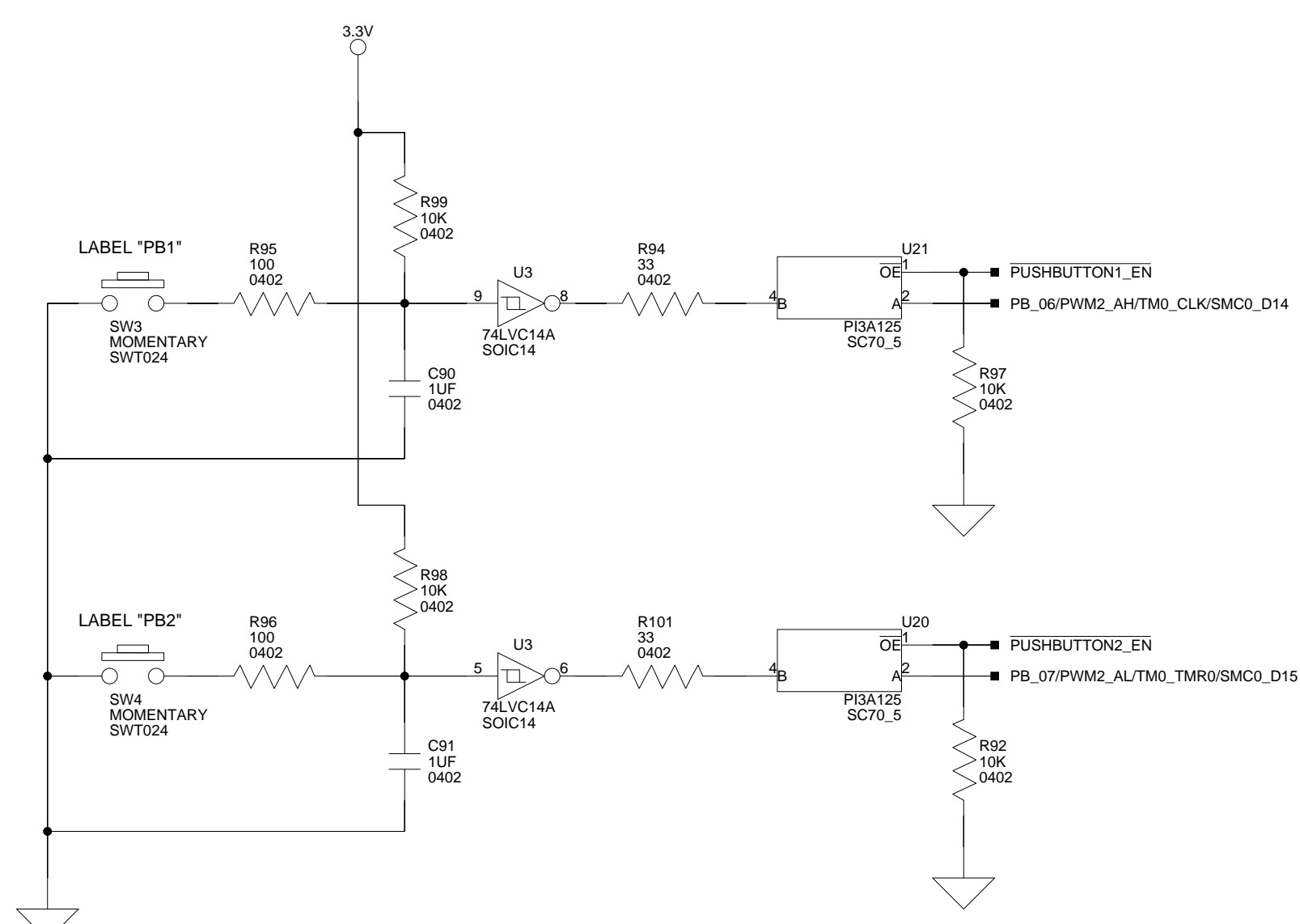
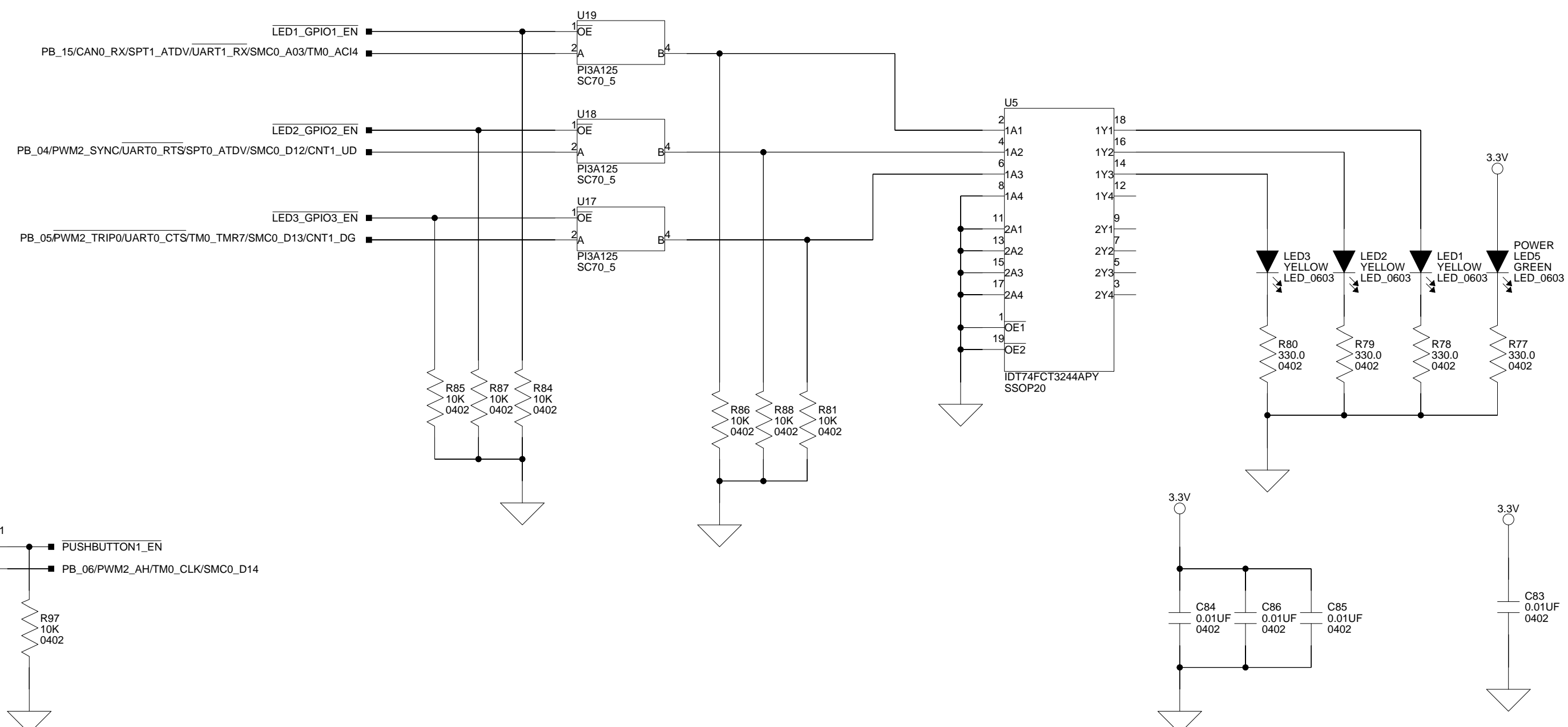

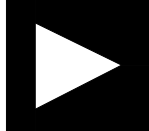
 ANALOG DEVICES		20 Cotton Road Nashua, NH 03063 PH: 1-800-ANALOGD	
		Title ADSP-CM403F EZ-KIT LEDS, PUSHBUTTONS AND RESET	
Size C	Board No. A0342-2012	Rev 1.0	
Date 08/27/2013	Sheet 9 of 10		

SJ6 SHORTING JUMPER DEFAULT=1&2

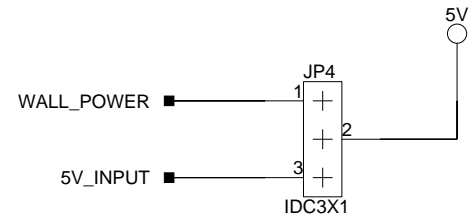

GND Test Points are scattered on PCB for Test Measurement Purposes.

LABEL "GND" ON ALL TPs

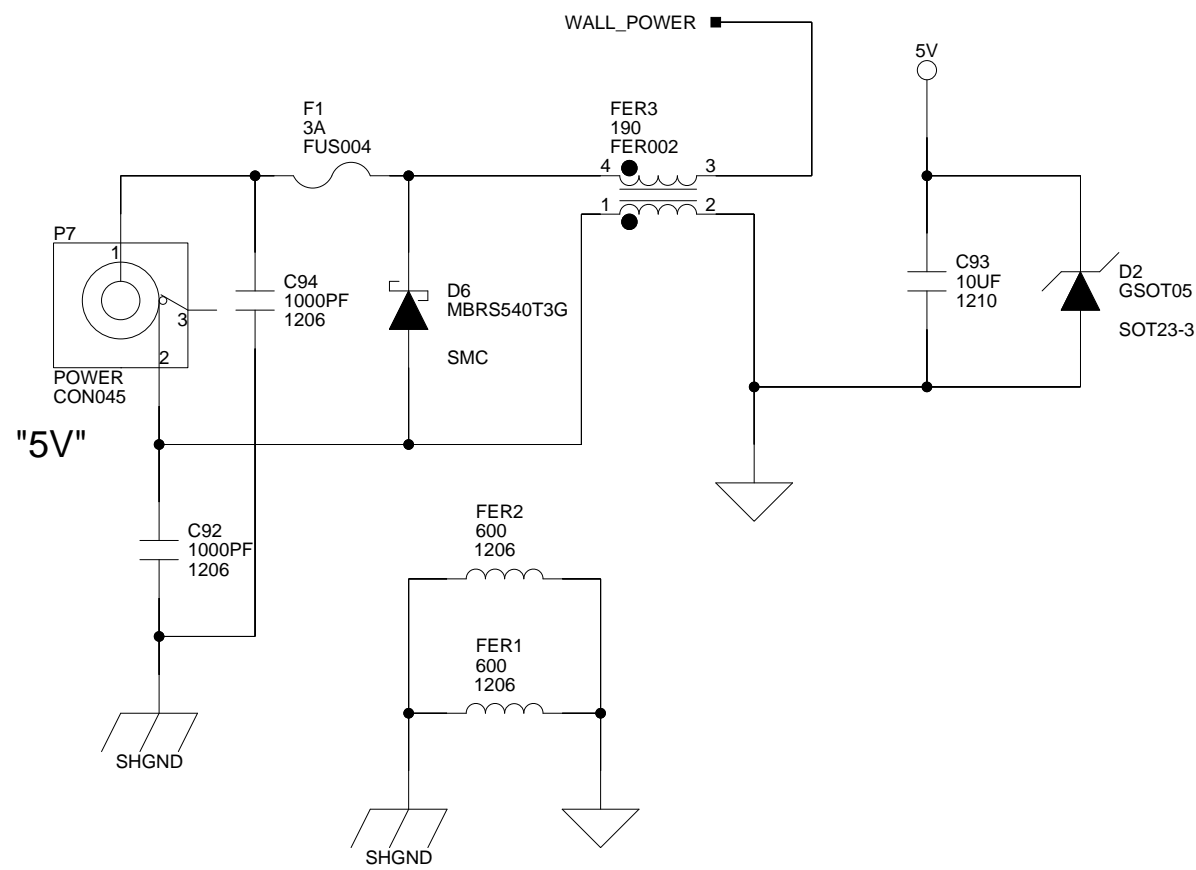
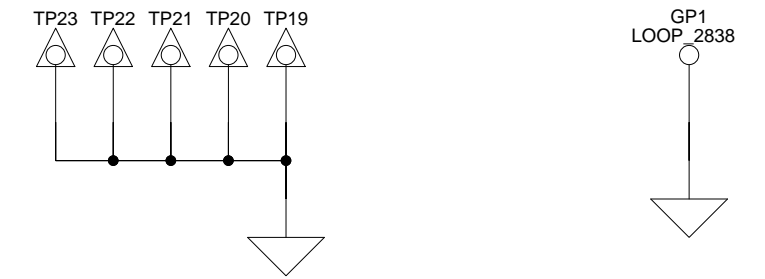

SJ7 SHORTING JUMPER DEFAULT=INSTALLED

3.3V @ 1.5A

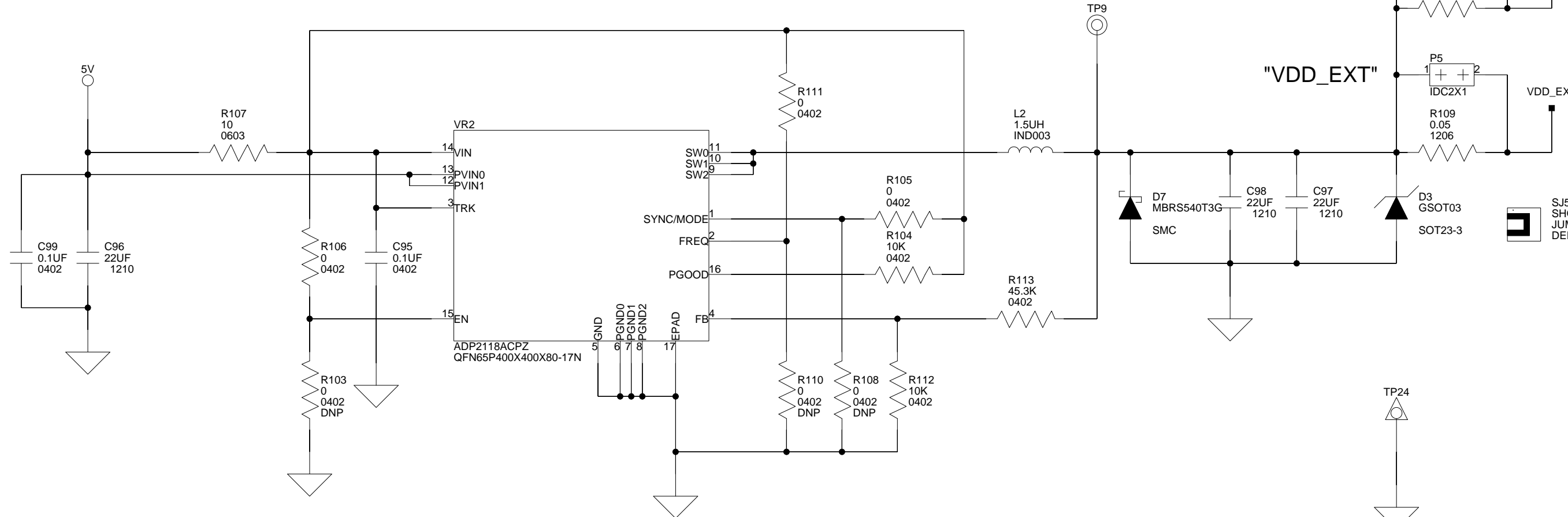

SJ5 SHORTING JUMPER DEFAULT=INSTALLED

"3.3V"

"VDD_EXT"

Remove P6 when measuring VDD_EXT

Remove P5 when measuring 3.3V

		20 Cotton Road Nashua, NH 03063 PH: 1-800-ANALOGD	
Title		ADSP-CM403F EZ-KIT VDD_EXT, 5V WALL	
Size C	Board No.	A0342-2012	Rev 1.0
Date	08/27/2013	Sheet 10	of 10

I INDEX

A

ADSP-CM403F processor, [x](#)
analog connector (J9), [2-21](#)
architecture, of this EZ-KIT Lite, [2-2](#)
asynch or memory connector (J2), [2-20](#)

B

bill of materials, [A-1](#)
board schematic (ADSP-CM403F), [B-1](#)
bus switch, [2-5](#)
 example, [2-6](#)

C

CAN0 connector (J8), [2-21](#)
character display connector (J3), [2-20](#)
configuration, of this EZ-KIT Lite, [1-3](#)
connectors, [2-19](#)
 diagram of locations, [2-19](#)
 J1 (DCE UART), [2-20](#)
 J2 (asynch or memory), [2-20](#)
 J3 (character display), [2-20](#)
 J7 (PWM), [2-21](#)
 J8 (CAN0), [2-21](#)
 J9 (analog), [2-21](#)
 P1 (JTAG/SWD/SWV), [2-21](#)
 P2 (TRACE and JTAG/SWD/SWV),
 [2-22](#)
 P3 (VREF buffered), [2-22](#)
 P7 (power), [2-22](#)
contents, of this EZ-KIT Lite package, [1-2](#)

D

DCE UART connector (J1), [2-20](#)
debug interface, [1-10](#)
default configuration, of this EZ-KIT Lite,
 [1-3](#)
default jumper and switch settings, [1-4](#)
default processor interface availability, [2-7](#)
design reference information, [1-13](#)

E

EngineerZone, [xviii](#)
example programs, [1-13](#)
expansion interface, [1-11](#)

F

FET switches, [2-4](#)
 example, [2-4](#)

G

general-purpose I/O pins (GPIO), [2-18](#)

I

installation, of this EZ-KIT Lite, [1-4](#), [1-5](#)

J

JTAG/SWD/SWV connector (P1), [2-21](#)
jumpers
 diagram of locations, [2-14](#)

Index

L

- LEDs, [2-17](#)
 - diagram of locations, [2-17](#)
 - LED1-3 (GPIO), [2-18](#)
 - LED4 (reset), [2-18](#)
 - LED5 (power), [2-18](#)
 - LED6 (SYS_FAULT), [2-18](#)

M

- mechanical switch, [2-5](#), [2-7](#)

N

- notation conventions, [xviii](#)

P

- package contents, [1-2](#)
- power
 - architecture, [1-12](#)
 - LED (LED5), [2-18](#)
 - measurements, [1-12](#)
- power connector (P7), [2-22](#)
- power-on-self test (POST), [1-11](#)
- product overview, [x](#)
- programming SoftConfig switches, [2-8](#)
- push buttons and switches, [2-12](#)
- PWM connector (J7), [2-21](#)

R

- reset LED (LED4), [2-18](#)

S

- schematic, of ADSP-CM403F EZ-KIT Lite, [B-1](#)
- serial liquid crystal display module
 - interface, [1-10](#)
- SoftConfig
 - on the EZ-KIT Lite, [2-7](#)
 - overview, [2-3](#)
 - programming switches, [2-8](#)
- supported tools, [xvii](#)
- switches
 - programming SoftConfig, [2-8](#)
- switches, diagram of locations, [2-12](#)
- SYS_FAULT LED (LED6), [2-18](#)
- system architecture, of this EZ-KIT Lite, [2-2](#)

T

- technical support, [xvi](#)
- TRACE and JTAG/SWD/SWV connector (P2), [2-22](#)

V

- VREF buffered connector (P3), [2-22](#)



Стандарт Электрон Связь

Мы молодая и активно развивающаяся компания в области поставок электронных компонентов. Мы поставляем электронные компоненты отечественного и импортного производства напрямую от производителей и с крупнейших складов мира.

Благодаря сотрудничеству с мировыми поставщиками мы осуществляем комплексные и плановые поставки широчайшего спектра электронных компонентов.

Собственная эффективная логистика и склад в обеспечивает надежную поставку продукции в точно указанные сроки по всей России.

Мы осуществляем техническую поддержку нашим клиентам и предпродажную проверку качества продукции. На все поставляемые продукты мы предоставляем гарантию .

Осуществляем поставки продукции под контролем ВП МО РФ на предприятия военно-промышленного комплекса России , а также работаем в рамках 275 ФЗ с открытием отдельных счетов в уполномоченном банке. Система менеджмента качества компании соответствует требованиям ГОСТ ISO 9001.

Минимальные сроки поставки, гибкие цены, неограниченный ассортимент и индивидуальный подход к клиентам являются основой для выстраивания долгосрочного и эффективного сотрудничества с предприятиями радиоэлектронной промышленности, предприятиями ВПК и научно-исследовательскими институтами России.

С нами вы становитесь еще успешнее!

Наши контакты:

Телефон: +7 812 627 14 35

Электронная почта: sales@st-electron.ru

Адрес: 198099, Санкт-Петербург,
Промышленная ул, дом № 19, литера Н,
помещение 100-Н Офис 331