



Low Capacitance, Low Charge Injection, 4- / 8-Channel, Triple SPDT, ± 5 V / 12 V / 5 V / 3 V Analog Multiplexers

DESCRIPTION

The DG4051E, DG4052E, and DG4053E are high precision CMOS analog multiplexers. The DG4051E is an 8-channel multiplexer, the DG4052E is a dual 4-channel multiplexer, and the DG4053E is a triple 2-channel multiplexer or triple SPDT.

The DG4051E, DG4052E, and DG4053E feature low leakage, parasitic capacitance, and low charge injection of 0.3 pC over the full voltage range. These devices are ideal for high precision signal switching and multiplexing.

Designed to operate from a 3 V to 16 V single supply or from a ± 3 V to ± 8 V dual supplies, the DG4051E, DG4052E, and DG4053E are fully specified at 3 V, 5 V, 12 V and ± 5 V. All control logic inputs have guaranteed 2 V logic high limit when operating from 5 V or ± 5 V supplies and 1.4 V when operating from a 3 V supply.

All switches conduct equally well in both directions, offering rail to rail analog signal switching and can be used both as multiplexers as well as de-multiplexers.

The DG4051E, DG4052E, and DG4053E operating temperature is specified from -40 °C to +125 °C and are available in 16 pin TSSOP and the ultra compact 1.8 mm x 2.6 mm miniQFN16 packages.

BENEFITS

- Wide operation voltage range
- Low charge injection
- Low parasitic capacitance
- Compact package option

FEATURES

- 3 V to 16 V single supply or ± 3 to ± 8 V dual supply operation
- Low parasitic capacitance:
 - $C_{D(ON)}$: 8.5 pF / typ. (DG4053E)
 - $C_{S(OFF)}$: 2.0 pF / typ. (DG4053E)
- Less than 0.3 pC charge injection over the full signal swing range
- Low leakage: < 50 pA, typ.
- Fast switching t_{ON} : 35 ns, typ.
- 3 V logic compatible for control
- Bi-directional rail to rail signal switching
- Material categorization: for definitions of compliance please see www.vishay.com/doc?99912



RoHS COMPLIANT

APPLICATIONS

- Automatic test equipment
- Process control and automation
- Data acquisition systems
- Meters and instruments
- Medical and healthcare systems
- Communication systems
- Audio and video signal routing
- Relay replacement
- Battery powered systems

FUNCTIONAL BLOCK DIAGRAM AND PIN CONFIGURATION



ENABLE = LO, all switches are controlled by addr pins.
ENABLE = HI, all switches are off.

FUNCTIONAL BLOCK DIAGRAM AND PIN CONFIGURATION

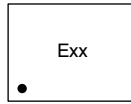
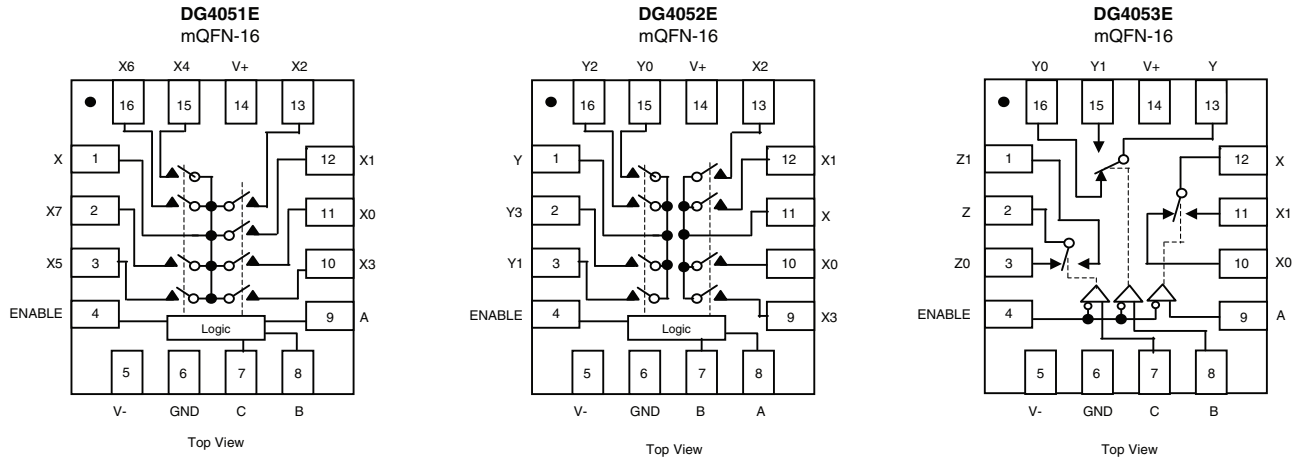

Pin 1

Device Marking: Exx for DG4051E
 (miniQFN16) Gxx for DG4052E
 Hxx for DG4053E
 xx = Date/Lot Traceability Code

TRUTH TABLE						
ENABLE INPUT	SELECT INPUTS			ON SWITCHES		
	C	B	A	DG4051E	DG4052E	DG4053E
H	X	X	X	All switches open	All switches open	All switches open
L	L	L	L	X to X0	X to X0, Y to Y0	X to X0, Y to Y0, Z to Z0
L	L	L	H	X to X1	X to X1, Y to Y1	X to X1, Y to Y0, Z to Z0
L	L	H	L	X to X2	X to X2, Y to Y2	X to X0, Y to Y1, Z to Z0
L	L	H	H	X to X3	X to X3, Y to Y3	X to X1, Y to Y1, Z to Z0
L	H	L	L	X to X4	X to X0, Y to Y0	X to X0, Y to Y0, Z to Z1
L	H	L	H	X to X5	X to X1, Y to Y1	X to X1, Y to Y0, Z to Z1
L	H	H	L	X to X6	X to X2, Y to Y2	X to X0, Y to Y1, Z to Z1
L	H	H	H	X to X7	X to X3, Y to Y3	X to X1, Y to Y1, Z to Z1

ORDERING INFORMATION				
TEMPERATURE RANGE	CONFIGURATION	PACKAGE	PART NUMBER	MIN. ORDER / PACKAGING QUANTITY
-40 °C to +125 °C ^a Lead (Pb)-Free	DG4051E	16-pin TSSOP	DG4051EEQ-T1-GE3	Tape and reel 3000 units
		16-pin SOIC	DG4051EEY-T1-GE3	Tape and reel 2500 units
		16-pin miniQFN	DG4051EEN-T1-GE4	Tape and reel 3000 units
	DG4052E	16-pin TSSOP	DG4052EEQ-T1-GE3	Tape and reel 3000 units
		16-pin SOIC	DG4052EEY-T1-GE3	Tape and reel 2500 units
		16-pin miniQFN	DG4052EEN-T1-GE4	Tape and reel 3000 units
	DG4053E	16-pin TSSOP	DG4053EEQ-T1-GE3	Tape and reel 3000 units
		16-pin SOIC	DG4053EEY-T1-GE3	Tape and reel 2500 units
		16-pin miniQFN	DG4053EEN-T1-GE4	Tape and reel 3000 units

Note

a. -40 °C to +85 °C datasheet limits apply.



ABSOLUTE MAXIMUM RATINGS (T _A = 25 °C, unless otherwise noted)			
PARAMETER	LIMIT		UNIT
V+ to V-	-0.3 to +18		V
GND to V-	-18		
Digital Inputs ^a , V _S , V _D	(V-) - 0.3 to (V+) + 0.3 or 30 mA, whichever occurs first		
Continuous Current (any terminal)	30		mA
Peak Current, S or D (pulsed 1 ms, 10 % duty cycle)	100		
Storage Temperature	-65 to +150		°C
Power Dissipation ^b	16-pin TSSOP ^c	450	mW
	16-pin miniQFN ^{d, f}	525	
	16-pin narrow SOIC ^e	640	
Thermal Resistance ^b	16-pin TSSOP ^c	178	°C/W
	16-pin miniQFN ^{d, f}	152	
	16-pin narrow SOIC ^e	125	
ESD Human Body Model (HBM); per ANSI / ESDA / JEDEC [®] JS-001	2500		V
Latch Up Current, per JESD78D	400		mA

Notes

- a. Signals on SX, DX, or INX exceeding V+ or V- will be clamped by internal diodes. Limit forward diode current to maximum current ratings.
- b. All leads welded or soldered to PC board.
- c. Derate 5.6 mW/°C above 70 °C.
- d. Derate 6.6 mW/°C above 70 °C.
- e. Derate 8.0 mW/°C above 70 °C.
- f. Manual soldering with iron is not recommended for leadless components. The miniQFN-16 is a leadless package. The end of the lead terminal is exposed copper (not plated) as a result of the singulation process in manufacturing. A solder fillet at the exposed copper lip cannot be guaranteed and is not required to ensure adequate bottom side solder interconnection.

Stresses beyond those listed under "Absolute Maximum Ratings" may cause permanent damage to the device. These are stress ratings only, and functional operation of the device at these or any other conditions beyond those indicated in the operational sections of the specifications is not implied. Exposure to absolute maximum rating conditions for extended periods may affect device reliability.

SPECIFICATIONS FOR DUAL SUPPLIES									
PARAMETER	SYMBOL	TEST CONDITIONS UNLESS OTHERWISE SPECIFIED V+ = 5 V, V- = -5 V V _{IN(A, B, C, and enable)} = 2 V, 0.8 V ^a	TEMP. ^b	TYP. ^c	-40 °C to +125 °C		-40 °C to +85 °C		UNIT
					MIN. ^d	MAX. ^d	MIN. ^d	MAX. ^d	
Analog Switch									
Analog Signal Range ^e	V _{ANALOG}		Full	-	-5	5	-5	5	V
On-Resistance	R _{ON}	I _S = 1 mA, V _D = -3 V, 0 V, 3 V	Room	68	-	78	-	78	Ω
			Full	-	-	106	-	97	
On-Resistance Match	ΔR _{ON}	I _S = 1 mA, V _D = ± 3 V	Room	0.91	-	6	-	6	Ω
			Full	-	-	6	-	6	
On-Resistance Flatness	R _{FLATNESS}	I _S = 1 mA, V _D = -3 V, 0 V, 3 V	Room	10	-	17	-	17	Ω
			Full	-	-	20	-	19	
Switch Off Leakage Current	I _{S(off)}	V+ = 5.5 V, V- = -5.5 V, V _D = ± 4.5 V, V _S = ± 4.5 V	Room	± 0.05	-1	1	-1	1	nA
			Full	-	-50	50	-5	5	
	Room		± 0.05	-1	1	-1	1		
	Full		-	-50	50	-5	5		
Channel On Leakage Current	I _{D(on)}	V+ = 5.5 V, V- = -5.5 V, V _S = V _D = ± 4.5 V	Room	± 0.05	-1	1	-1	1	nA
			Full	-	-50	50	-5	5	
Digital Control									
Input Current, V _{IN} Low	I _{IL}	V _{IN(A, B, C, and enable)} under test = 0.6 V	Full	0.02	-1	1	-1	1	μA
Input Current, V _{IN} High	I _{IH}	V _{IN(A, B, C, and enable)} under test = 2 V	Full	0.02	-1	1	-1	1	
Input Capacitance ^e	C _{IN}	f = 1 MHz	Room	3.4	-	-	-	-	pF



SPECIFICATIONS FOR DUAL SUPPLIES										
PARAMETER	SYMBOL	TEST CONDITIONS UNLESS OTHERWISE SPECIFIED V+ = 5 V, V- = -5 V VIN(A, B, C, and enable) = 2 V, 0.8 V ^a	TEMP. ^b	TYP. ^c	-40 °C to +125 °C		-40 °C to +85 °C		UNIT	
					MIN. ^d	MAX. ^d	MIN. ^d	MAX. ^d		
Dynamic Characteristics										
Off Isolation ^e	OIRR	R _L = 50 Ω, C _L = 1 pF	f = 100 kHz	Room	-106	-	-	-	-	dB
			f = 10 MHz	Room	-68	-	-	-	-	
			f = 100 MHz	Room	-49	-	-	-	-	
Channel-to-Channel Crosstalk ^e	X _{TALK}	R _L = 50 Ω, C _L = 1 pF	f = 100 kHz	Room	-105	-	-	-	-	dB
			f = 10 MHz	Room	-62	-	-	-	-	
			f = 100 MHz	Room	-51	-	-	-	-	
Bandwidth, 3 dB	BW	R _L = 50 Ω	DG4051E	Room	308	-	-	-	-	MHz
			DG4052E	Room	353	-	-	-	-	
			DG4053E	Room	930	-	-	-	-	
Transition Time	t _{TRANS}	R _L = 300 Ω, C _L = 35 pF see Fig. 1, 2, 3	Room	72	-	112	-	112	ns	
			Full	-	-	139	-	131		
Enable Turn-On Time	t _{ON}		Room	35	-	75	-	75		
			Full	-	-	86	-	80		
Enable Turn-Off Time	t _{OFF}		Room	48	-	88	-	88		
			Full	-	-	97	-	95		
Break-Before-Make Time Delay	t _D		Room	-	1	-	1	-		
			Full	-	-	-	-	-		
Charge Injection ^e	Q	V _g = 0 V, R _g = 0 Ω, C _L = 1 nF	Room	0.38	-	-	-	-	pC	
Source Off Capacitance ^e	C _{S(off)}	f = 1 MHz	DG4051E	Room	2.2	-	-	-	-	pF
			DG4052E	Room	2.1	-	-	-	-	
			DG4053E	Room	2	-	-	-	-	
Drain Off Capacitance ^e	C _{D(off)}	f = 1 MHz	DG4051E	Room	9.2	-	-	-	-	pF
			DG4052E	Room	4.8	-	-	-	-	
			DG4053E	Room	3.1	-	-	-	-	
Channel On Capacitance ^e	C _{D(on)}	f = 1 MHz	DG4051E	Room	14.9	-	-	-	-	pF
			DG4052E	Room	10	-	-	-	-	
			DG4053E	Room	8.5	-	-	-	-	
Total Harmonic Distortion ^e	THD	Signal = 5 V _{RMS} , 20 Hz to 20 kHz, R _L = 600 Ω	Room	0.065	-	-	-	-	%	
Power Supplies										
Power Supply Current	I+	V+ = 5 V, V- = -5 V VIN(A, B, C, and enable) = 0 V or 5 V	Room	0.05	-	1	-	1	μA	
			Full	-	-	10	-	10		
Negative Supply Current	I-		Room	-0.05	-1	-	-1	-		
			Full	-	-10	-	-10	-		
Ground Current	I _{GND}		Room	-0.05	-1	-	-1	-		
			Full	-	-10	-	-10	-		



SPECIFICATIONS FOR UNIPOLAR SUPPLIES											
PARAMETER	SYMBOL	TEST CONDITIONS UNLESS OTHERWISE SPECIFIED V+ = 12 V, V- = 0 V VIN(A, B, C, and enable) = 2 V, 0.8 V ^a	TEMP. ^b	TYP. ^c	-40 °C to +125 °C		-40 °C to +85 °C		UNIT		
					MIN. ^d	MAX. ^d	MIN. ^d	MAX. ^d			
Analog Switch											
Analog Signal Range ^e	V _{ANALOG}		Full	-	0	12	0	12	V		
On-Resistance	R _{ON}	I _S = 1 mA, V _D = 0.7 V, 11.3 V	Room	85	-	103	-	103	Ω		
			Full	-	-	133	-	125			
On-Resistance Match	ΔR _{ON}	I _S = 1 mA, V _D = 11.3 V	Room	1.24	-	8	-	8	Ω		
			Full	-	-	8	-	8			
On-Resistance Flatness	R _{FLATNESS}	I _S = 1 mA, V _D = 0.7 V, 11.3 V	Room	27	-	37	-	37	Ω		
			Full	-	-	44	-	43			
Switch Off Leakage Current	I _{S(off)}	V+ = 13.2 V, V- = 0 V V _D = 1 V / 12.2 V, V _S = 12.2 V / 1 V	Room	± 0.05	-1	1	-1	1	nA		
			Full	-	-50	50	-5	5			
	I _{D(off)}		Room	± 0.05	-1	1	-1	1			
			Full	-	-50	50	-5	5			
Channel On Leakage Current	I _{D(on)}	V+ = 13.2 V, V- = 0 V V _D = V _S = 1 V / 12.2 V	Room	± 0.05	-1	1	-1	1			
			Full	-	-50	50	-5	5			
Digital Control											
Input Current, V _{IN} Low	I _L	V _{IN(A, B, C, and enable)} under test = 0.8 V	Full	0.02	-1	1	-1	1	μA		
Input Current, V _{IN} High	I _H	V _{IN(A, B, C, and enable)} under test = 2 V	Full	0.02	-1	1	-1	1			
Dynamic Characteristics											
Transition Time	t _{TRANS}	R _L = 300 Ω, C _L = 35 pF see Fig. 1, 2, 3	Room	43	-	83	-	83	ns		
			Full	-	-	95	-	90			
Enable Turn-On Time	t _{ON}		Room	22	-	62	-	62			
			Full	-	-	71	-	67			
Enable Turn-Off Time	t _{OFF}		Room	47	-	87	-	87			
			Full	-	-	94	-	93			
Break-Before-Make Time Delay	t _D		Room	25	1	-	1	-			
			Full	-	-	-	-	-			
Charge Injection ^e	Q		V _g = 0 V, R _g = 0 Ω, C _L = 1 nF	Full	-	-	-	-		-	pC
Off Isolation ^e	OIRR		R _L = 50 Ω, C _L = 1 pF f = 100 kHz	Room	-	-	-	-		-	dB
Channel-to-Channel Crosstalk ^e	X _{TALK}	Room		-	-	-	-	-			
Source Off Capacitance ^e	C _{S(off)}	f = 1 MHz	DG4051E	Room	-	-	-	-	pF		
			DG4052E	Room	-	-	-	-			
			DG4053E	Room	-	-	-	-			
Drain Off Capacitance ^e	C _{D(off)}	f = 1 MHz	DG4051E	Room	-	-	-	-	pF		
			DG4052E	Room	-	-	-	-			
			DG4053E	Room	-	-	-	-			
Channel On Capacitance ^e	C _{D(on)}	f = 1 MHz	DG4051E	Room	-	-	-	-	pF		
			DG4052E	Room	-	-	-	-			
			DG4053E	Room	-	-	-	-			
Power Supplies											
Power Supply Current	I+	V _{IN(A, B, C, and enable)} = 0 V or 5 V	Room	0.05	-	1	-	1	μA		
			Full	-	-	10	-	10			
Negative Supply Current	I-		Room	-0.05	-1	-	-1	-			
			Full	-	-10	-	-10	-			
Ground Current	I _{GND}		Room	-0.05	-1	-	-1	-			
			Full	-	-10	-	-10	-			



SPECIFICATIONS FOR UNIPOLAR SUPPLIES											
PARAMETER	SYMBOL	TEST CONDITIONS UNLESS OTHERWISE SPECIFIED V ₊ = 5 V, V ₋ = 0 V V _{IN(A, B, C, and enable)} = 2 V, 0.8 V ^a	TEMP. ^b	TYP. ^c	-40 °C to +125 °C		-40 °C to +85 °C		UNIT		
					MIN. ^d	MAX. ^d	MIN. ^d	MAX. ^d			
Analog Switch											
Analog Signal Range ^e	V _{ANALOG}		Full	-	0	5	0	5	V		
On-Resistance	R _{ON}	I _S = 1 mA, V _D = 0 V, 3.5 V	Room	125	-	147	-	147	Ω		
			Full	-	-	176	-	168			
On-Resistance Match	ΔR _{ON}	I _S = 1 mA, V _D = 3.5 V	Room	1.3	-	8	-	8	Ω		
			Full	-	-	8	-	8			
On-Resistance Flatness	R _{FLATNESS}	I _S = 1 mA, V _D = 0 V, 3 V	Room	21	-	31	-	31	Ω		
			Full	-	-	25	-	29			
Switch Off Leakage Current	I _{S(off)}	V ₊ = 5.5 V, V ₋ = 0 V V _D = 1 V / 4.5 V, V _S = 4.5 V / 1 V	Room	± 0.03	-1	1	-1	1	nA		
			Full	-	-50	50	-5	5			
	Room		± 0.03	-1	1	-1	1				
	Full		-	-50	50	-5	5				
Channel On Leakage Current	I _{D(on)}	V ₊ = 5.5 V, V ₋ = 0 V V _D = V _S = 1 V / 4.5 V	Room	± 0.03	-1	1	-1	1	nA		
			Full	-	-50	50	-5	5			
Digital Control											
Input Current, V _{IN} Low	I _L	V _{IN(A, B, C, and enable)} under test = 0.6 V	Full	0.02	-1	1	-1	1	μA		
Input Current, V _{IN} High	I _H	V _{IN(A, B, C, and enable)} under test = 2 V	Full	0.02	-1	1	-1	1			
Dynamic Characteristics											
Transition Time	t _{TRANS}	R _L = 300 Ω, C _L = 35 pF see Fig. 1, 2, 3	Room	95	-	135	-	135	ns		
			Full	-	-	169	-	148			
Enable Turn-On Time	t _{ON}		Room	56	-	96	-	96			
			Full	-	-	117	-	107			
Enable Turn-Off Time	t _{OFF}		Room	55	-	95	-	95			
			Full	-	-	110	-	103			
Break-Before-Make Time Delay	t _D		Room	-	12	-	12	-			
			Full	-	-	-	-	-			
Charge Injection ^e	Q		V _g = 0 V, R _g = 0 Ω, C _L = 1 nF	Full	0.32	-	-	-		-	pC
Off Isolation ^e	OIRR		R _L = 50 Ω, C _L = 1 pF f = 100 kHz	Room	-86	-	-	-		-	dB
Channel-to-Channel Crosstalk ^e	X _{TALK}	Room		-105	-	-	-	-			
Source Off Capacitance ^e	C _{S(off)}	f = 1 MHz	DG4051E	Room	2.4	-	-	-	-	pF	
			DG4052E	Room	2.4	-	-	-	-		
			DG4053E	Room	2.3	-	-	-	-		
Drain Off Capacitance ^e	C _{D(off)}	f = 1 MHz	DG4051E	Room	10.1	-	-	-	-		
			DG4052E	Room	5.3	-	-	-	-		
			DG4053E	Room	3.4	-	-	-	-		
Channel On Capacitance ^e	C _{D(on)}	f = 1 MHz	DG4051E	Room	15.9	-	-	-	-		
			DG4052E	Room	10.6	-	-	-	-		
			DG4053E	Room	8.9	-	-	-	-		
Power Supplies											
Power Supply Current	I ₊	V _{IN(A, B, C, and enable)} = 0 V or 5 V	Room	0.05	-	1	-	1	μA		
			Full	-	-	10	-	10			
Negative Supply Current	I ₋		Room	-0.05	-1	-	-1	-			
			Full	-	-10	-	-10	-			
Ground Current	I _{GND}		Room	-0.05	-1	-	-1	-			
			Full	-	-10	-	-10	-			



SPECIFICATIONS FOR UNIPOLAR SUPPLIES											
PARAMETER	SYMBOL	TEST CONDITIONS UNLESS OTHERWISE SPECIFIED $V_+ = 3\text{ V}, V_- = 0\text{ V}$ $V_{IN(A, B, C, \text{ and enable})} = 1.4\text{ V}, 0.6\text{ V}^a$	TEMP. ^b	TYP. ^c	-40 °C to +125 °C		-40 °C to +85 °C		UNIT		
					MIN. ^d	MAX. ^d	MIN. ^d	MAX. ^d			
Analog Switch											
Analog Signal Range ^e	V_{ANALOG}		Full	-	0	3	0	3	V		
On-Resistance	R_{ON}	$I_S = 1\text{ mA}, V_D = 1.5\text{ V}$	Room	221	-	-	-	-	Ω		
			Full	-	-	-	-				
Switch Off Leakage Current	$I_{S(off)}$	$V_+ = 3.3\text{ V}, V_- = 0\text{ V}$ $V_D = 0.3\text{ V} / 3\text{ V}, V_S = 3\text{ V} / 0.3\text{ V}$	Room	± 0.02	-1	1	-1	1	nA		
			Full	-	-50	50	-5	5			
	$I_{D(off)}$		Room	± 0.02	-1	1	-1	1			
			Full	-	-50	50	-5	5			
Channel On Leakage Current	$I_{D(on)}$	$V_+ = 3.3\text{ V}, V_- = 0\text{ V}$ $V_D = V_S = 0.3\text{ V} / 3\text{ V}$	Room	± 0.02	-1	1	-1	1			
			Full	-	-50	50	-5	5			
Digital Control											
Input Current, V_{IN} Low	I_L	$V_{IN(A, B, C, \text{ and enable})}$ under test = 0.6 V	Full	0.02	-1	1	-1	1	μA		
Input Current, V_{IN} High	I_H	$V_{IN(A, B, C, \text{ and enable})}$ under test = 1.4 V	Full	0.02	-1	1	-1	1			
Dynamic Characteristics											
Transition Time	t_{TRANS}	$R_L = 300\ \Omega, C_L = 35\text{ pF}$ see Fig. 1, 2, 3	Room	200	-	-	-	-	ns		
			Full	-	-	-	-	-			
Enable Turn-On Time	t_{ON}		Room	130	-	-	-	-			
			Full	-	-	-	-	-			
Enable Turn-Off Time	t_{OFF}		Room	78	-	-	-	-			
			Full	-	-	-	-	-			
Break-Before-Make Time Delay	t_D		Room	130	-	-	-	-			
			Full	-	-	-	-	-			
Charge Injection ^e	Q		$V_g = 0\text{ V}, R_g = 0\ \Omega, C_L = 1\text{ nF}$	Room	0.34	-	-	-		-	pC
Off Isolation ^e	OIRR		$R_L = 50\ \Omega, C_L = 1\text{ pF}$ $f = 100\text{ kHz}$	Room	-88	-	-	-		-	dB
Channel-to-Channel Crosstalk ^e	X_{TALK}	Room		-105	-	-	-	-			
Source Off Capacitance ^e	$C_{S(off)}$	$f = 1\text{ MHz}$	DG4051E	Room	2.6	-	-	-	-		
			DG4052E	Room	2.6	-	-	-	-		
			DG4053E	Room	2.5	-	-	-	-		
Drain Off Capacitance ^e	$C_{D(off)}$	$f = 1\text{ MHz}$	DG4051E	Room	10.7	-	-	-	-		
			DG4052E	Room	5.7	-	-	-	-		
			DG4053E	Room	3.6	-	-	-	-		
Channel On Capacitance ^e	$C_{D(on)}$	$f = 1\text{ MHz}$	DG4051E	Room	16.4	-	-	-	-		
			DG4052E	Room	10.9	-	-	-	-		
			DG4053E	Room	9.1	-	-	-	-		
Power Supplies											
Power Supply Current	I_+	$V_{IN(A, B, C, \text{ and enable})} = 0\text{ V or }3\text{ V}$	Room	0.05	-	1	-	1	μA		
			Full	-	-	10	-	10			
Negative Supply Current	I_-		Room	-0.05	-1	-	-1	-			
			Full	-	-10	-	-10	-			
Ground Current	I_{GND}		Room	-0.05	-1	-	-1	-			
			Full	-	-10	-	-10	-			

Notes

- a. V_{IN} = input voltage to perform proper function.
- b. Room = 25 °C, full = as determined by the operating temperature suffix.
- c. Typical values are for DESIGN AID ONLY, not guaranteed nor subject to production testing.
- d. The algebraic convention whereby the most negative value is a minimum and the most positive a maximum, is used in this datasheet.
- e. Guaranteed by design, not subject to production test.



TYPICAL CHARACTERISTICS (25 °C, unless otherwise noted)

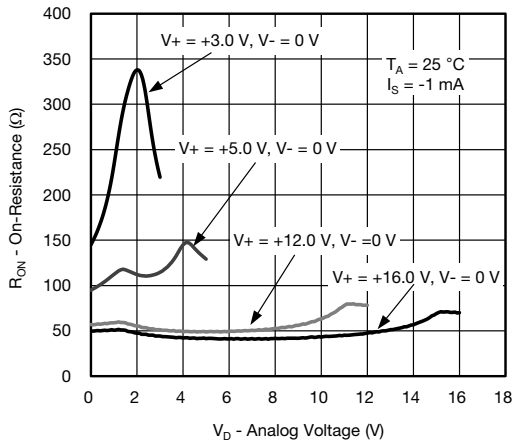

On-Resistance vs. Analog Voltage (Single Supply)

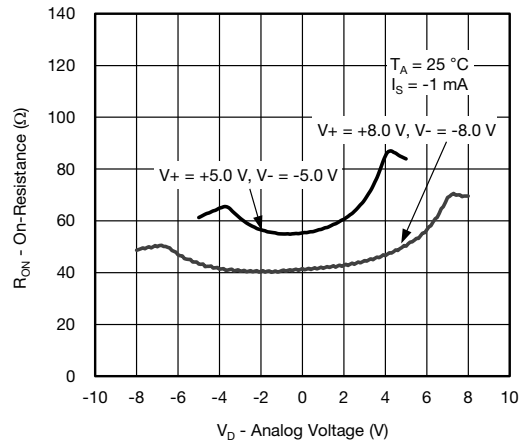

On-Resistance vs. Analog Voltage (Dual Supply)

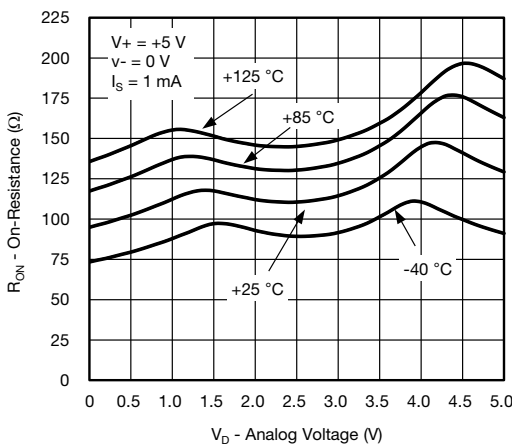

On-Resistance vs. Analog Voltage (Temperature)

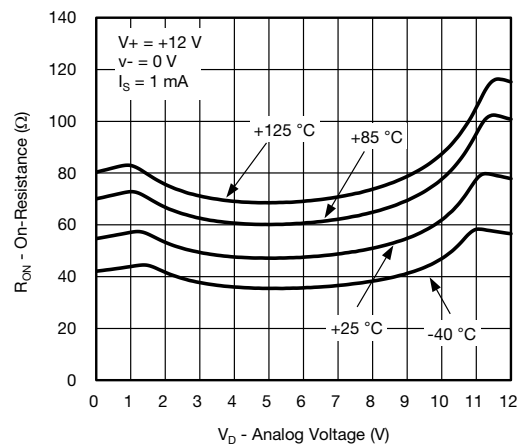

On-Resistance vs. Analog Voltage (Temperature)

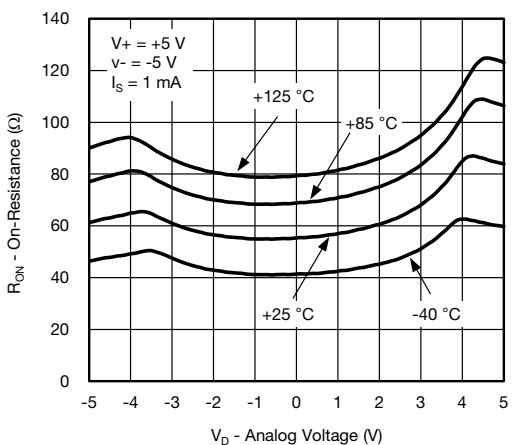

On-Resistance vs. Analog Voltage (Temperature)

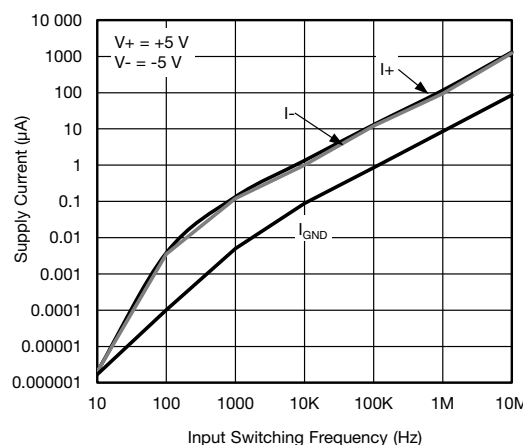

Supply Current vs. Input Switching Frequency



TYPICAL CHARACTERISTICS (25 °C, unless otherwise noted)

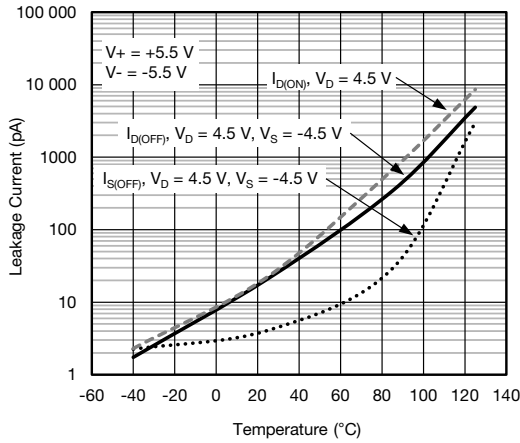

Leakage Current vs. Temperature

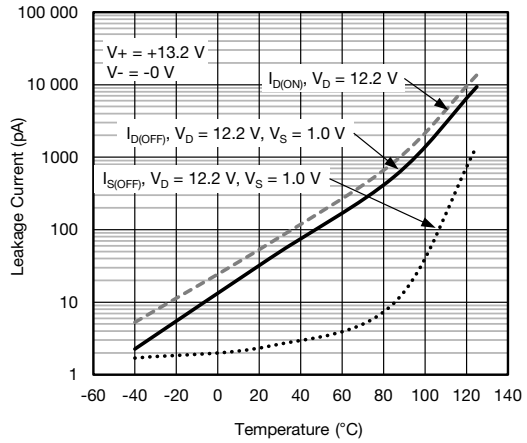

Leakage Current vs. Temperature



Switching Time vs. Temperature (Single Supply)



Switching Time vs. Temperature (Dual Supply)



DG4051E Insertion Loss, Off-Isolation, Crosstalk vs. Frequency



DG4052E Insertion Loss, Off-Isolation, Crosstalk vs. Frequency



TYPICAL CHARACTERISTICS (25 °C, unless otherwise noted)



DG4053E Insertion Loss, Off-Isolation, Crosstalk vs. Frequency



Switching Threshold vs. V+ Supply Voltage



DG4051E Charge Injection vs. Analog Voltage



DG4053E Charge Injection vs. Analog Voltage

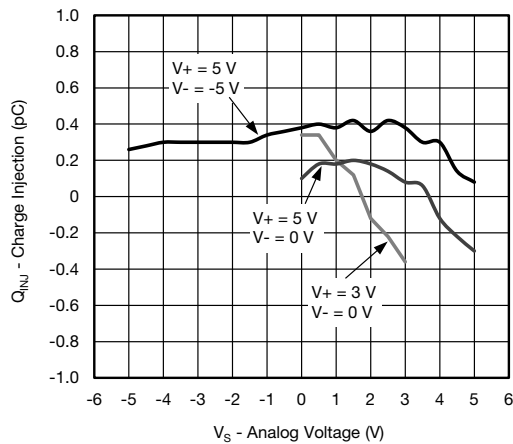

DG4052E Charge Injection vs. Analog Voltage

SCHEMATIC DIAGRAM (Typical Channel)

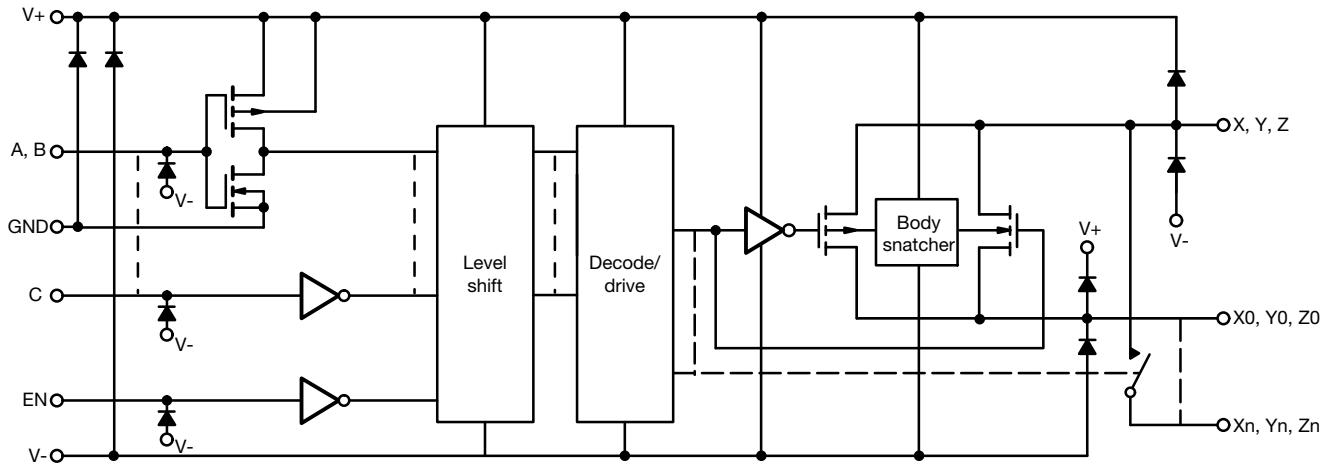

TEST CIRCUITS

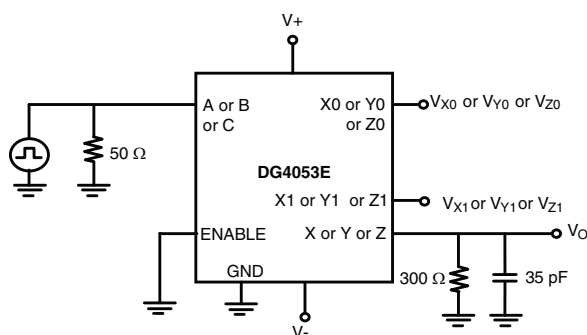
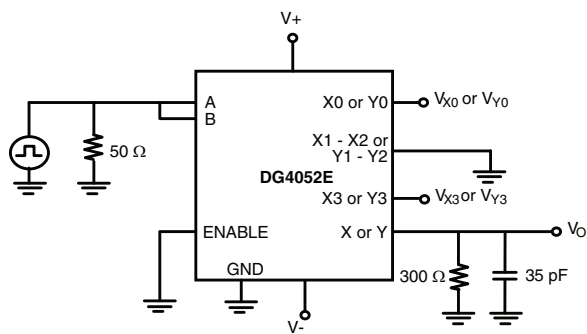
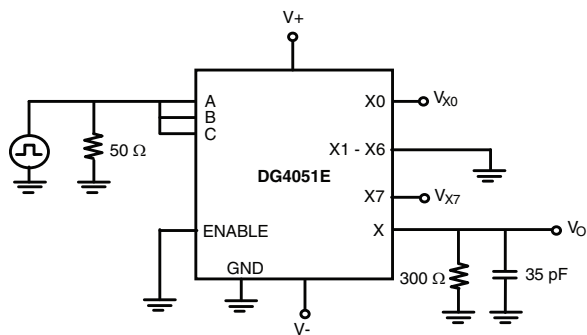
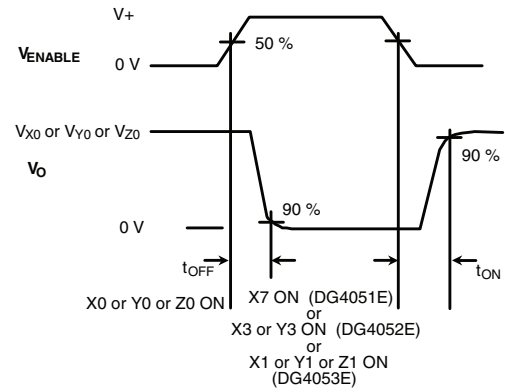
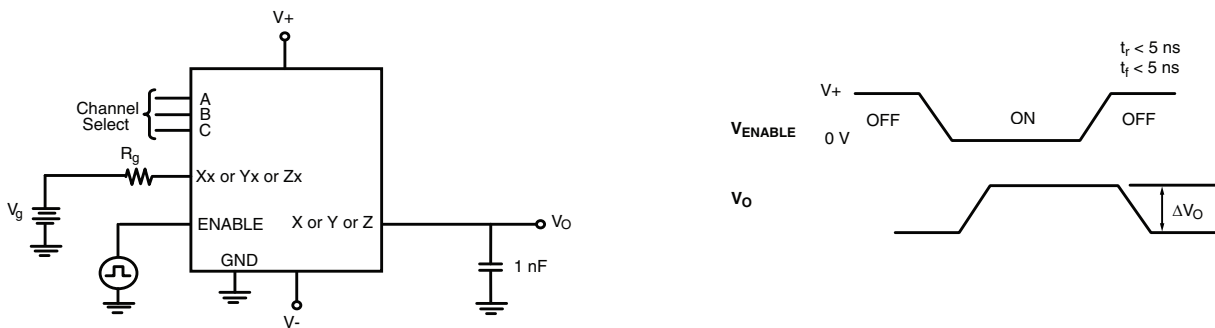

Fig. 1 - Transition Time

TEST CIRCUITS

Fig. 2 - Enable Switching Time

TEST CIRCUITS

Fig. 3 - Break-Before-Make

Fig. 4 - Charge Injection

TEST CIRCUITS



Fig. 5 - Insertion Loss



Fig. 7 - Off Isolation



Fig. 6 - Crosstalk

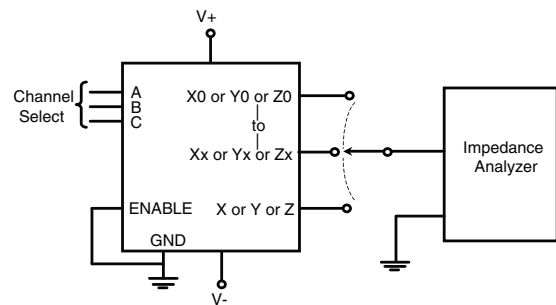

Fig. 8 - Source, Drain Capacitance

Vishay Siliconix maintains worldwide manufacturing capability. Products may be manufactured at one of several qualified locations. Reliability data for Silicon Technology and Package Reliability represent a composite of all qualified locations. For related documents such as package/tape drawings, part marking, and reliability data, see www.vishay.com/ppg?69685.



SOIC (NARROW): 16-LEAD
JEDEC Part Number: MS-012



Dim	MILLIMETERS		INCHES	
	Min	Max	Min	Max
A	1.35	1.75	0.053	0.069
A ₁	0.10	0.20	0.004	0.008
B	0.38	0.51	0.015	0.020
C	0.18	0.23	0.007	0.009
D	9.80	10.00	0.385	0.393
E	3.80	4.00	0.149	0.157
e	1.27 BSC		0.050 BSC	
H	5.80	6.20	0.228	0.244
L	0.50	0.93	0.020	0.037
∅	0°	8°	0°	8°

ECN: S-03946—Rev. F, 09-Jul-01
DWG: 5300





miniQFN-16L

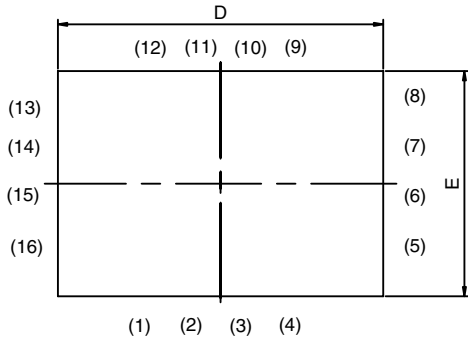

BACK SIDE VIEW



DIM	MILLIMETERS			INCHES		
	MIN.	NAM	MAX.	MIN.	NAM	MAX.
A	0.70	0.75	0.80	0.0275	0.0295	0.0315
A1	0	-	0.05	0	-	0.002
b	0.15	0.20	0.25	0.0059	0.0078	0.0098
C	0.15	0.20	0.25	0.0059	0.0078	0.0098
D	2.50	2.60	2.70	0.0984	0.1023	0.1063
E	1.70	1.80	1.90	0.0669	0.0708	0.0748
e	0.40 BSC			0.0157 BSC		
L	0.35	0.40	0.45	0.0137	0.0157	0.0177
L1	0.45	0.50	0.55	0.0177	0.0196	0.0216

ECN T16-0234-Rev. B, 09-May-16
 DWG: 5954

TSSOP: 16-LEAD



Symbols	DIMENSIONS IN MILLIMETERS		
	Min	Nom	Max
A	-	1.10	1.20
A1	0.05	0.10	0.15
A2	-	1.00	1.05
B	0.22	0.28	0.38
C	-	0.127	-
D	4.90	5.00	5.10
E	6.10	6.40	6.70
E1	4.30	4.40	4.50
e	-	0.65	-
L	0.50	0.60	0.70
L1	0.90	1.00	1.10
y	-	-	0.10
θ1	0°	3°	6°

ECN: S-61920-Rev. D, 23-Oct-06
DWG: 5624



RECOMMENDED MINIMUM PAD FOR TSSOP-16



Recommended Minimum Pads
Dimensions in inches (mm)

RECOMMENDED MINIMUM PADS FOR MINI QFN 16L



Mounting Footprint
Dimensions in mm (inch)

RECOMMENDED MINIMUM PADS FOR SO-16



Recommended Minimum Pads
Dimensions in Inches/(mm)

[Return to Index](#)



Disclaimer

ALL PRODUCT, PRODUCT SPECIFICATIONS AND DATA ARE SUBJECT TO CHANGE WITHOUT NOTICE TO IMPROVE RELIABILITY, FUNCTION OR DESIGN OR OTHERWISE.

Vishay Intertechnology, Inc., its affiliates, agents, and employees, and all persons acting on its or their behalf (collectively, "Vishay"), disclaim any and all liability for any errors, inaccuracies or incompleteness contained in any datasheet or in any other disclosure relating to any product.

Vishay makes no warranty, representation or guarantee regarding the suitability of the products for any particular purpose or the continuing production of any product. To the maximum extent permitted by applicable law, Vishay disclaims (i) any and all liability arising out of the application or use of any product, (ii) any and all liability, including without limitation special, consequential or incidental damages, and (iii) any and all implied warranties, including warranties of fitness for particular purpose, non-infringement and merchantability.

Statements regarding the suitability of products for certain types of applications are based on Vishay's knowledge of typical requirements that are often placed on Vishay products in generic applications. Such statements are not binding statements about the suitability of products for a particular application. It is the customer's responsibility to validate that a particular product with the properties described in the product specification is suitable for use in a particular application. Parameters provided in datasheets and/or specifications may vary in different applications and performance may vary over time. All operating parameters, including typical parameters, must be validated for each customer application by the customer's technical experts. Product specifications do not expand or otherwise modify Vishay's terms and conditions of purchase, including but not limited to the warranty expressed therein.

Except as expressly indicated in writing, Vishay products are not designed for use in medical, life-saving, or life-sustaining applications or for any other application in which the failure of the Vishay product could result in personal injury or death. Customers using or selling Vishay products not expressly indicated for use in such applications do so at their own risk. Please contact authorized Vishay personnel to obtain written terms and conditions regarding products designed for such applications.

No license, express or implied, by estoppel or otherwise, to any intellectual property rights is granted by this document or by any conduct of Vishay. Product names and markings noted herein may be trademarks of their respective owners.

Material Category Policy

Vishay Intertechnology, Inc. hereby certifies that all its products that are identified as RoHS-Compliant fulfill the definitions and restrictions defined under Directive 2011/65/EU of The European Parliament and of the Council of June 8, 2011 on the restriction of the use of certain hazardous substances in electrical and electronic equipment (EEE) - recast, unless otherwise specified as non-compliant.

Please note that some Vishay documentation may still make reference to RoHS Directive 2002/95/EC. We confirm that all the products identified as being compliant to Directive 2002/95/EC conform to Directive 2011/65/EU.

Vishay Intertechnology, Inc. hereby certifies that all its products that are identified as Halogen-Free follow Halogen-Free requirements as per JEDEC JS709A standards. Please note that some Vishay documentation may still make reference to the IEC 61249-2-21 definition. We confirm that all the products identified as being compliant to IEC 61249-2-21 conform to JEDEC JS709A standards.



Стандарт Электрон Связь

Мы молодая и активно развивающаяся компания в области поставок электронных компонентов. Мы поставляем электронные компоненты отечественного и импортного производства напрямую от производителей и с крупнейших складов мира.

Благодаря сотрудничеству с мировыми поставщиками мы осуществляем комплексные и плановые поставки широчайшего спектра электронных компонентов.

Собственная эффективная логистика и склад в обеспечивает надежную поставку продукции в точно указанные сроки по всей России.

Мы осуществляем техническую поддержку нашим клиентам и предпродажную проверку качества продукции. На все поставляемые продукты мы предоставляем гарантию .

Осуществляем поставки продукции под контролем ВП МО РФ на предприятия военно-промышленного комплекса России , а также работаем в рамках 275 ФЗ с открытием отдельных счетов в уполномоченном банке. Система менеджмента качества компании соответствует требованиям ГОСТ ISO 9001.

Минимальные сроки поставки, гибкие цены, неограниченный ассортимент и индивидуальный подход к клиентам являются основой для выстраивания долгосрочного и эффективного сотрудничества с предприятиями радиоэлектронной промышленности, предприятиями ВПК и научно-исследовательскими институтами России.

С нами вы становитесь еще успешнее!

Наши контакты:

Телефон: +7 812 627 14 35

Электронная почта: sales@st-electron.ru

Адрес: 198099, Санкт-Петербург,
Промышленная ул, дом № 19, литера Н,
помещение 100-Н Офис 331