

Boosted Class D Amplifier with Speaker-Protection Monitoring and Flash LED Drivers

Mono Class D Speaker Amplifier

- Two-level Class G operation:
 - Boosted: 5 V nominal
 - Bypassed: battery voltage is supplied directly
- 2.5-mA quiescent current, monitors powered down
- 1.7 W into 8 Ω (@ 10% THD+N)
- 102-dB signal-to-noise ratio (SNR, A-weighted)
- Idle channel noise 25 μ Vrms (A-weighted)
- 90% efficiency

Audio Input and Gain

- One differential analog input
- Speaker gain:
 - 9, 12, 15, and 18 dB and mute
 - Pop suppression, zero-crossing detect transitions

Flash LED Drivers

- Integrated dual LED drivers using the following:
 - Boost supply output voltage
 - Dual matched current regulators, 750 mA max each
- Programmable setting for Flash Mode current: 50–750 mA, in 50-mA steps
- Programmable setting for Flash-Inhibit Mode current: 50–350 mA, in 50-mA steps
- Programmable setting for Movie Mode current: 150, 120, 100, 80, 60, 40, 20 mA
- Programmable flash timer setting: 50–500 ms, in 25-ms steps
- Dedicated pin for flash trigger (FLEN)
- Dedicated pin for flash inhibit (FLINH)
- Thermally managed through boost-voltage regulation

(Features continue on page 2)

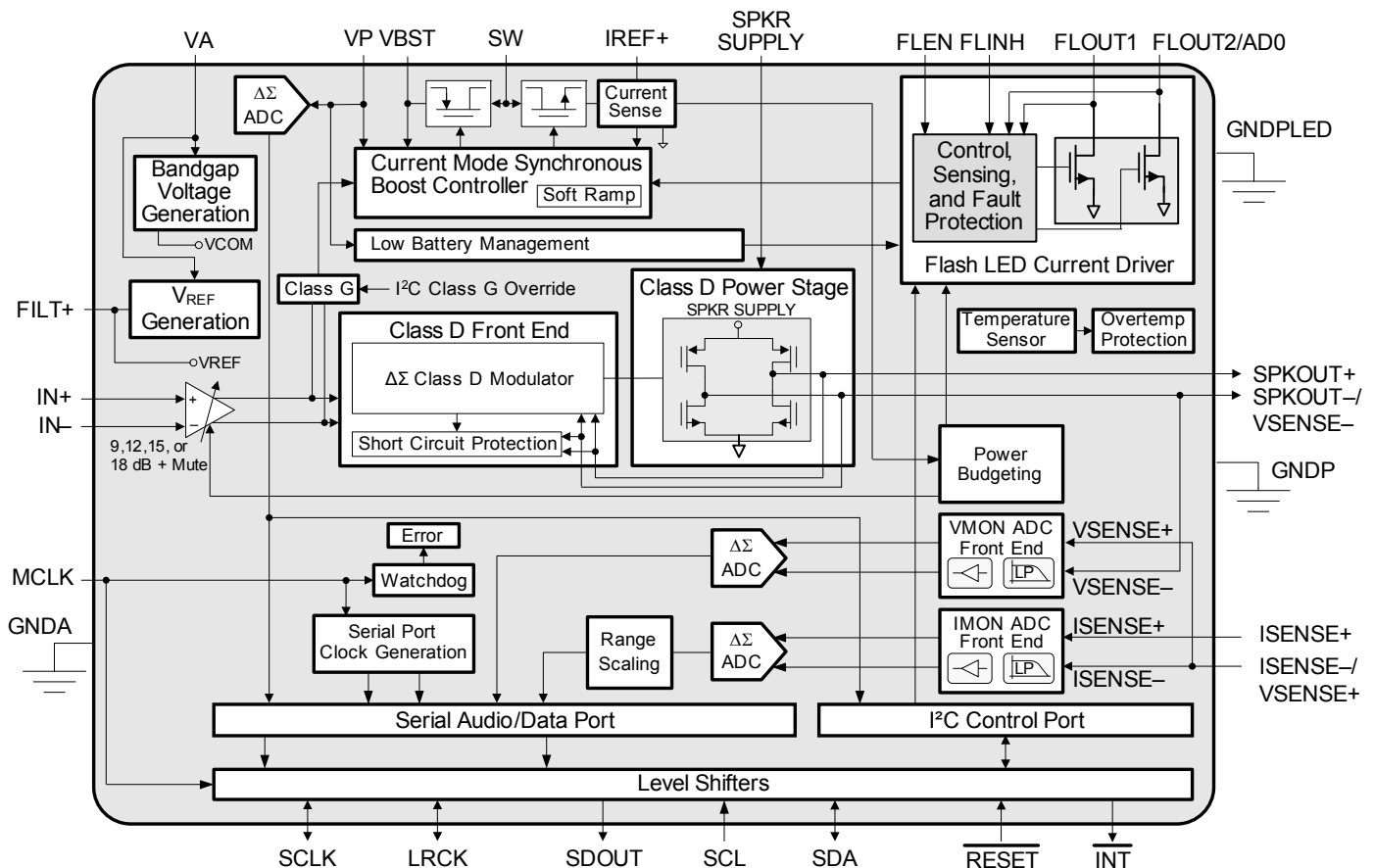

Monitors and Protection

- Protection:
 - Latched overtemperature shutdown
 - Latched amplifier output short circuit shutdown
 - LED short or open detection and LED driver shutdown
 - Flash inhibit LED current reduction
 - Low battery flash LED current reduction
 - VP undervoltage lockout (UVLO) shutdown
 - Programmable boost inductor current limiting
 - Audio and LED shutdown upon stopped MCLK, with autorecovery
 - Interrupt driven error reporting
- Speaker current and voltage monitoring:
 - 16-bit resolution
 - 60-dB dynamic range (unweighted) for voltage
 - 56-dB dynamic range (unweighted) for current
 - Bused over I²S bus
- Battery voltage monitoring:
 - 7-bit resolution
 - Bused over I²S and I²C bus
- System reset

I²C Control Settings and Registers

- Low-power standby
- LED and audio power budgeting programmable settings
- Boost inductor current limit programmable setting
- Speaker programmable settings:
 - Pop suppression through zero-crossing transitions
 - Gain and mute
- Battery voltage monitor register, 8 bits
- LED driver programmable settings:
 - Flash current register
 - Flash inhibit current register
 - Movie Mode current register
 - Flash timer register

General Description

The CS35L32 is a low-quiescent power-integrated audio IC, with a mono full-bridge Class D speaker amplifier operating with a self-boosted Class G supply. Audio input is received differentially. Pop-and-click reduction is achieved with zero-crossing transitions at turn-on, turn-off and upon gain changes. Communication with the host processor is done using an I²C interface. In addition, an I²S bus is used to send monitor and status data.

When two CS35L32 devices are available on the same board, each is identified by its I²C chip address. Upon power-up or upon deasserting $\overline{\text{RESET}}$, each CS35L32 reads the AD0 pin logic level and configures its I²C device address.

The speaker amplifier, using closed-loop $\Delta\Sigma$ modulation, achieves low levels of distortion. Class D amplifier efficiency allows operation at higher speaker power levels without generating excessive heat and without wasting power. Automatic Class G operation using a boosted supply to the speaker allows for even higher powers and higher crest factor. With a boosted speaker supply, operation at a fixed 5 V is achieved independently of line supplied battery voltage. The user can disable Class G operation.

- Error status bit, including the following:
 - Stopped MCLK error
 - Low battery detection with programmable thresholds
 - VP UVLO error
 - Overtemperature warning
 - Overtemperature error
 - Boost converter overvoltage error
 - Boost inductor current-limiting error
 - Amplifier short-circuit error
 - Shorted or open LED error

I²S Reporting

- Monitoring:
 - Speaker voltage monitor
 - Speaker current monitor
 - Battery voltage monitor
- Error reporting:
 - VP UVLO shutdown error
 - Overtemperature warning
 - Overtemperature error
 - Boost converter overvoltage error
 - Boost inductor current limiting error
 - Amplifier short-circuit error
 - Speaker voltage monitor overflow error
 - Speaker current monitor overflow error
 - Battery voltage monitor overflow error
- Status reporting:
 - Power-down done
 - LED flash event
 - LED Movie Mode event
 - Flash timer on

Package

- 30-ball WLCSP

Applications

- Smart phones
- Tablets

The battery voltage, speaker voltage, and speaker current signals are monitored, digitized using $\Delta\Sigma$ converters, and serialized over an I²S bus. The speaker monitoring signals are part of a speaker-protection algorithm that is managed externally to the CS35L32. Outgoing data is sent over I²S with the CS35L32 in Slave or Master Mode. Battery voltage monitor data is accessible through I²C.

An integrated dual LED driver operates up to two LEDs in Flash Mode or Movie Mode. A flash event is triggered by an external signal. A flash-inhibit event is triggered by an external signal, and causes a reduction in flash current. A timer is provided for flash and flash inhibit events. Movie Mode operation has no timer and starts and ends via an I²C command. Flash and Movie Mode current levels, as well as the flash timer are I²C programmable.

Total power consumption when powering LEDs in Flash Mode or Movie Mode, and powering audio simultaneously, is managed by the user's choices in programming the current limit and in power budgeting. The primary goal is to manage audio and LED loads so the boost converter is not current limited and so the CS35L32 does not shut down due to overheating.

A latched shutdown of the audio amplifier occurs in the event of an output short pin to ground, pin to supply, or pin to pin. A latched shutdown of the CS35L32 also occurs on overtemperature. An LED driver shutdown occurs in the event of a shorted or open LED. The CS35L32 shuts down in the event of a battery (VP) undervoltage and autorecovers when the battery voltage recovers. The CS35L32 shuts down in the event of a stopped MCLK and autorecovers when MCLK recovers.

The CS35L32 responds to detection of a low battery in the presence of a flash event by reducing flash current and autorecovers when the battery voltage recovers.

The CS35L32 is reset by asserting $\overline{\text{RESET}}$. CS35L32 power up and power down are managed through the $\overline{\text{RESET}}$ pin.

The CS35L32 is available in a 30-ball WLCSP package in the temperature range -10 to $+70^{\circ}\text{C}$.

Table of Contents

1 Pin Descriptions	5	6 Register Quick Reference	35
2 Typical Connection Diagram	7	7 Register Descriptions	36
3 Characteristics and Specifications	8	7.1 Device ID A and B	36
Table 3-1. Recommended Operating Conditions	8	7.2 Device ID C and D	36
Table 3-2. Absolute Maximum Ratings	8	7.3 Device ID E	36
Table 3-3. DC Characteristics	8	7.4 Revision ID	36
Table 3-4. Boost Converter Characteristics	9	7.5 Power Control 1	36
Table 3-5. LED Drive Characteristics	9	7.6 Power Control 2	37
Table 3-6. Speaker Amplifier Output Characteristics	10	7.7 Clocking Control	37
Table 3-7. Signal Monitoring Characteristics	11	7.8 Low Battery Thresholds	37
Table 3-8. Digital Interface Specifications and Characteristics	11	7.9 Battery Voltage Monitor	38
Table 3-9. PSRR Characteristics	12	7.10 Boost Converter Peak Current Protection Control	38
Table 3-10. Power Consumption	12	7.11 Scaling	38
Table 3-11. Switching Specifications: Power, Reset, Master Clocks	12	7.12 LED and Audio Power-Budget Management	38
Table 3-12. Switching Specifications: ADSP in I ² S Mode	13	7.13 ADSP Control	39
Table 3-13. Switching Specifications: I ² C Control Port	14	7.14 Class D Amplifier Control	39
4 Functional Description	15	7.15 Protection Release Control	39
4.1 Power Supplies	15	7.16 Interrupt Mask 1	40
4.2 Interrupts	15	7.17 Interrupt Mask 2	40
4.3 Speaker Amplifier	16	7.18 Interrupt Mask 3	41
4.4 Low-Battery Management	17	7.19 Interrupt Status 1 (Audio)	41
4.5 Undervoltage Lockout (UVLO)	18	7.20 Interrupt Status 2 (Monitors)	42
4.6 Boost Converter	18	7.21 Interrupt Status 3 (LEDs and Boost Converter)	42
4.7 Die Temperature Monitoring	18	7.22 LED Lighting Status	43
4.8 Signal Monitoring	19	7.23 LED Flash Mode Current	43
4.9 LED Driver	21	7.24 LED Movie Mode Current	44
4.10 Power Budgeting	23	7.25 LED Flash Timer	44
4.11 Audio/Data Serial Port (ADSP)	24	7.26 LED Flash Inhibit Current	44
4.12 Signaling Format	26	8 Typical Performance Plots	45
4.13 Device Clocking	29	8.1 System-Level Efficiency and Power-Consumption Plots	45
4.14 Control Port Operation	30	8.2 Audio Output Typical Performance Plots	46
5 Applications	32	8.3 Monitoring Typical Performance Plots	47
5.1 Required Reserved Register Configuration	32	9 Parameter Definitions	49
5.2 Avoiding Current Transients when Issuing a Flash Event	32	10 Package Dimensions	50
5.3 External Component and PCB Design Considerations—EMI Out-put Filtering	33	11 Thermal Characteristics	50
5.4 PCB Routing Considerations for Thermal Relief	33	12 Ordering Information	51
5.5 Inductor Selection	34	13 References	51
		14 Revision History	51

1 Pin Descriptions

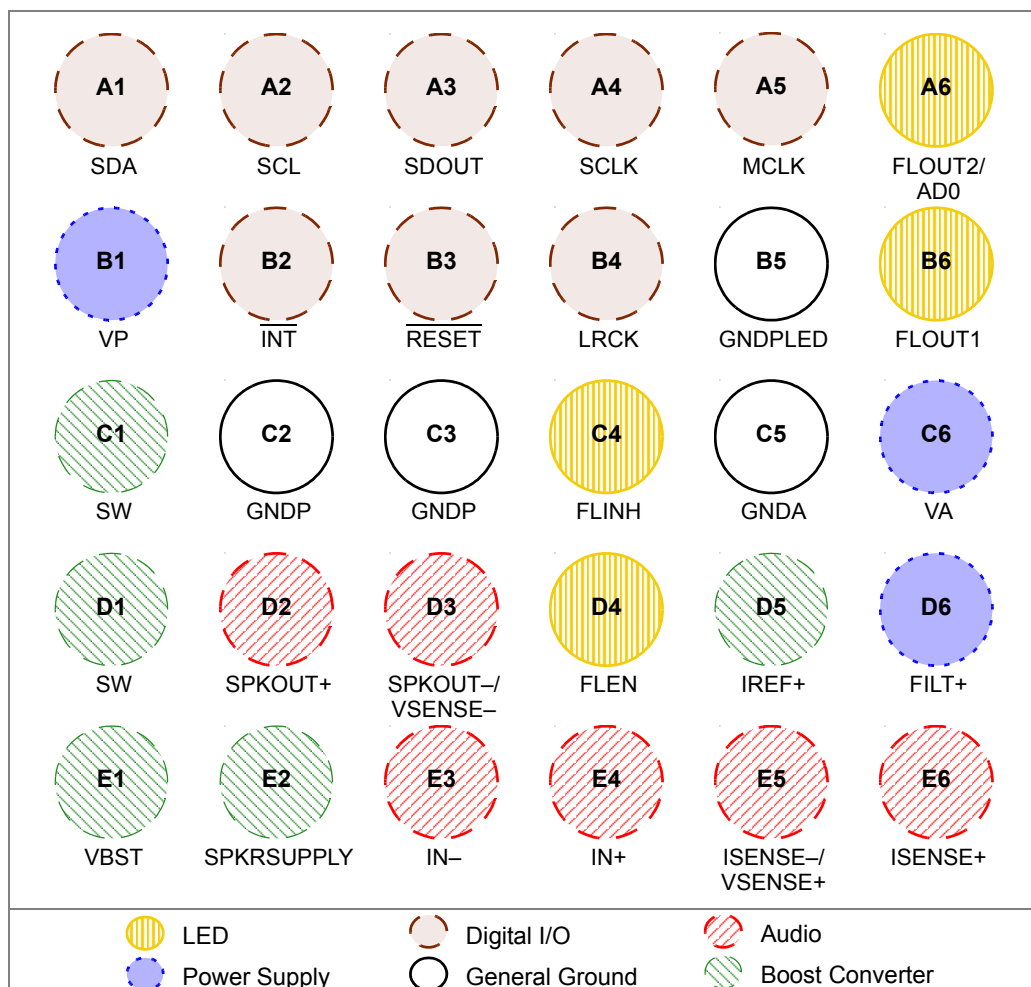

Figure 1-1. Top-Down (Through-Package) View—30-Ball WLCSP Package

Table 1-1. Pin Descriptions







Ball Name	Ball Number	Power Supply	I/O	Ball Description	Internal Connection	Driver	Receiver	State at Reset
Digital I/O 								
SDA	A1	VA	I/O	I²C Serial Data Input. Serial data for the I ² C serial port	—	CMOS open-drain output	Hysteresis on CMOS input	Hi-Z
SCL	A2	VA	I	I²C Clock Input. Serial clock for the I ² C serial port	—	—	Hysteresis on CMOS input	Hi-Z
MCLK	A5	VA	I	Master Clock Source. Clock source for A/D converters and audio/data serial port (ADSP). MCLK _{INT} , derived from MCLK, is used for other blocks (see Section 4.13 and Section 7.7).	Weak pull-down (~1 MΩ)	—	Hysteresis on CMOS input	Pulled down
SCLK	A4	VA	I/O	Serial Clock. Serial shift clock for the serial audio interface	Weak pull-down (~1 MΩ)	CMOS output	Hysteresis on CMOS input	Pulled down
LRCK	B4	VA	I/O	Left Right Clock. Determines which channel, left or right, is currently active on the serial audio/data lines	Weak pull-down (~1 MΩ)	CMOS output	Hysteresis on CMOS input	Pulled down
SDOUT	A3	VA	O	Serial Audio/Data Output. I ² S serial data output used to monitor voltage and current of SPKOUT signal and VP levels	Weak pull-down (~1 MΩ)	CMOS output	—	Pulled down
INT	B2	VA	O	Interrupt. Programmable, open-drain, active-low programmable interrupt output	—	CMOS open-drain output	—	Hi-Z

Table 1-1. Pin Descriptions (Cont.)

Ball Name	Ball Number	Power Supply	I/O	Ball Description	Internal Connection	Driver	Receiver	State at Reset
RESET	B3	VA	I	Reset. When asserted, the device enters a low-power mode, outputs are set to Hi-Z, and I ² C register values are set to defaults. Outputs are Hi-Z except those with weak pull-ups or pull-downs as mentioned.	—	—	Hysteresis on CMOS input	Low
LED 								
FLEN	D4	VA	I	Flash Enable. Input signal commanding a flash event into both LEDs. It is asserted high.	Weak pull-down (~1 MΩ)	—	Hysteresis on CMOS input	Pulled down
FLINH	C4	VA	I	Flash Inhibit. Input signal determining whether the LEDs are in Flash Mode (logic low) or Flash-Inhibit Mode (logic high, LED current reduced).	Weak pull-down (~1 MΩ)	—	Hysteresis on CMOS input	Pulled down
FLOUT1	B6	SPKR SUPPLY	O	LED Driver 1. Output driving LED 1 by sinking current from the LED cathode	Weak pull-up (~1 MΩ)	—	—	SPKR SUPPLY
FLOUT2/AD0	A6	SPKR SUPPLY	I/O	LED Driver 2/Address Zero. Output driving LED 2 by sinking current from the LED cathode. AD0 programs the chip address when RESET is deasserted. If no LED is used, tying the pin to ground clears the chip address LSB. Otherwise, the LSB is set.	Weak pull-up (~1 MΩ)	—	—	SPKR SUPPLY
Boost Converter 								
VBST	E1	—	O	Boost Converter Output. Output of boosted supply. This pin cannot be used to drive any external loads other than the on chip Class D Amplifier and Flash LEDs.	—	—	—	—
SPKR SUPPLY	E2	—	I	Speaker Supply. Full-bridge Class D speaker amplifier power supply.	—	—	—	—
SW	C1, D1	VBST	I	Boost Converter Switch Node. Connects the inductor to the rectifying switch.	—	—	—	—
IREF+	D5	VA	I	Current Reference Resistor. Connection for an external resistor to be used for generating the CS35L32's internal main current reference. See Fig. 2-1 for required resistor value.	—	—	—	—
Audio 								
IN+	E4	SPKR SUPPLY	I	Input 1 Differential Positive Line. Positive analog input	—	—	—	—
IN-	E3	SPKR SUPPLY	I	Input 1 Differential Negative Line. Negative analog input	—	—	—	—
SPKOUT+	D2	SPKR SUPPLY	O	Speaker Differential Audio Output. Internal Class D speaker amplifier output. SPKOUT- serves as voltage monitor negative sense pin (VSENSE-).	—	—	—	Hi-Z
SPKOUT-/VSENSE-	D3	SPKR SUPPLY	O					
ISENSE+	E6	SPKR SUPPLY	I	Current Sense Inputs. Sense voltage across an external resistor in series with SPKOUT+. ISENSE- serves as voltage monitor positive sense pin (VSENSE+).	—	—	—	—
ISENSE-/VSENSE+	E5	SPKR SUPPLY	I					
Power Supply 								
FILT+	D6	VA	O	Positive Voltage Reference. Positive reference for internal circuits	—	—	—	—
VA	C6	—	I	Analog Input Power. Power supply for internal analog section	—	—	—	—
VP	B1	—	I	Boost Converter Input Power. Power supply or battery voltage powering boost converter	—	—	—	—
General Ground 								
GNDA	C5	—	—	Analog Ground. Ground reference for the internal analog section of the IC	—	—	—	—
GNDP	C2, C3	—	—	Power Ground. Ground reference for boost converter and Class D amplifier's output stage	—	—	—	—
GNDPLED	B5	—	—	LED Power Ground. Ground reference for LED current return. Should be tied to ground plane.	—	—	—	—

2 Typical Connection Diagram

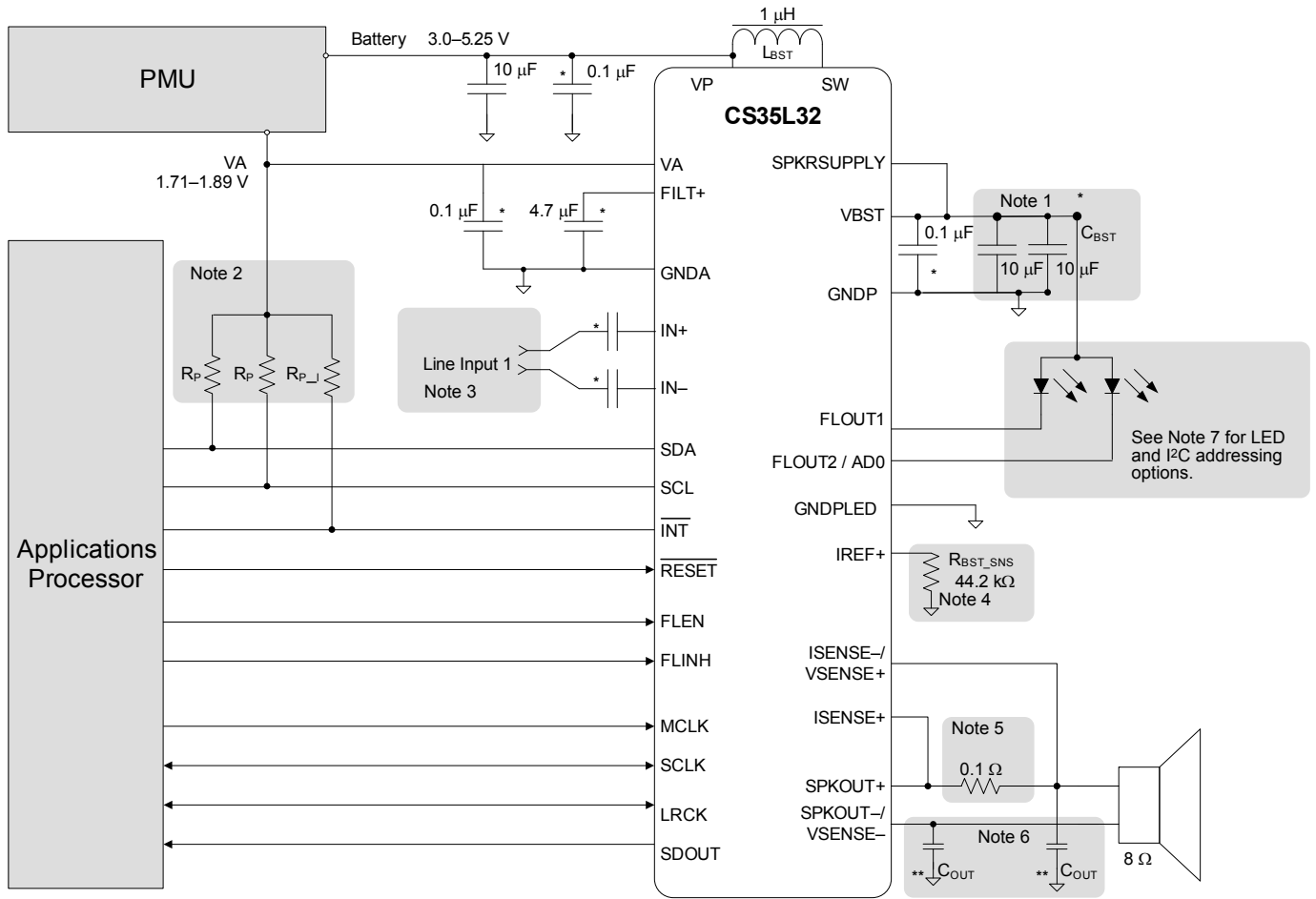

Notes:

- All external passive component values are nominal values.
 - Key for capacitor types required:
 - * Use low ESR, X7R/X5R capacitors.
 - ** Use low ESR, X7R capacitors.
 - If no type symbol is shown next to a capacitor, any type may be used.
 - As required, add protection circuitry to ensure compliance with the absolute maximum ratings in [Table 3-2](#).
1. C_{BST} is a ceramic capacitor and derates at DC voltages higher than 0 V. In this application, the capacitor should not derate to a value lower than 4 μF across the specified boost output voltage in [Table 3-4](#). Capacitor tolerance and the temperature coefficient should also be taken into account to guarantee the 4- μF value.
 2. Minimum pull-up resistor values are selected in accordance with the [Table 3-8](#) V_{OL} specification. Maximum pull-up resistances are selected based on load capacitance and relevant switching specs ([Table 3-13](#)).
 3. Select each capacitor to be 0.22 μF for an 18-Hz passband @ 12-dB amplifier gain, for a 3-dB roll-off. The equation for calculating the capacitance for a given passband is $C = 1/(\pi * f * R_{INDIF})$, where C is in F, R_{INDIF} is the differential input resistance in Ω , and f is in Hz (see the differential input resistance specification in [Table 3-3](#)). Signals IN+ and IN- are subject to the recommended ranges in [Table 3-1](#).
 4. R_{BST_SNS} is inherently tied to the accuracy of the BST_IPK current limit. A resistor with a 0.1% tolerance is required for this component to meet the specified $I_{MAX}(B)$ max and min values in [Table 3-4](#).
 5. The required tolerance on the 0.1- Ω ISENSE resistor is 1%. The required temperature coefficient is ± 200 ppm/ $^{\circ}\text{C}$.
 6. C_{OUT} capacitors are optional EMI suppressors used with CS35L32 edge-rate control, depending on application requirements. Because switching losses increase linearly with increases to these capacitances, it is recommended that C_{OUT} values not exceed 2 nF. The recommended value is 470 pF.
 7. LED and I²C addressing options:

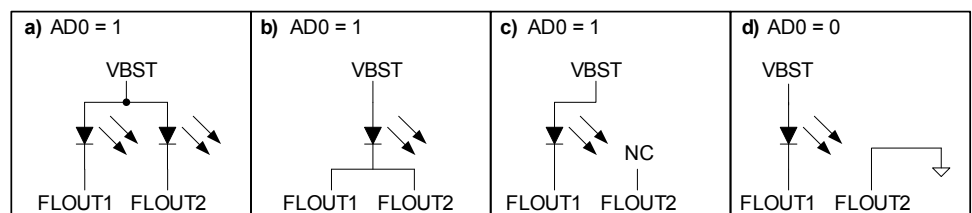

Figure 2-1. Typical Connection Diagram

3 Characteristics and Specifications

Table 3-1. Recommended Operating Conditions

GNDA = GNDD = 0 V, all voltages with respect to ground. Device functional operation is guaranteed within these limits. Functionality is not guaranteed or implied outside of these limits. Operation outside of these limits may adversely affect device reliability.

Parameters	Symbol	Minimum	Maximum	Units	
DC power supply	Analog (and digital I/O and core)	VA	1.71	1.89	V
	Battery	VP	3.0	5.25	V
External voltage applied to analog inputs powered by VA (IREF+, FILT+) ¹	V _{INAS}	-0.3	VA + 0.3	V	
External voltage applied to analog inputs powered by SPKRSUPPLY (IN+, IN-, ISENSE+, ISENSE-, VSENSE+, VSENSE-)	V _{INSS}	-0.3	SPKRSUPPLY + 0.3	V	
External voltage applied to digital inputs	V _{INDI}	-0.3	VA + 0.3	V	
Ambient temperature	TA	-10	+70	°C	

1. The maximum overvoltage/undervoltage is limited by the input current.

Table 3-2. Absolute Maximum Ratings

GNDA = GNDD = 0 V; all voltages with respect to ground. Operation at or beyond these limits may permanently damage the device.

Parameters	Symbol	Minimum	Maximum	Units	
DC power supply	Analog	VA	-0.3	2.22	V
	Battery	VP	-0.3	6.0	V
Input current ¹	I _{IN}	—	±10	mA	
Ambient operating temperature (local to device, power applied)	T _A	-40	+115	°C	
Junction operating temperature (power applied)	T _J	-40	+150	°C	
Storage temperature	T _{STG}	-65	+150	°C	

1. Any pin except supplies. Transient currents of up to ±100 mA on the analog input pins do not cause SCR latch up.

Table 3-3. DC Characteristics

Test conditions, except where noted otherwise: VA = 1.8 V, VP = 3.6 V, VBST = 5.0 V, GNDA = GNDD = 0 V, TA = +25°C.

Parameters	Symbol	Test Conditions	Min	Typical	Max	Units
Differential Input resistance (IN+ to IN-)	R _{INDIF}	Amp gain = 9 dB	—	63	—	kΩ
		Amp gain = 12 dB	—	51	—	kΩ
		Amp gain = 15 dB	—	40	—	kΩ
		Amp gain = 18 dB	—	31	—	kΩ
FILT+ voltage	—	—	—	VA	—	—
Overtemperature shutdown threshold	T _{OP}	—	—	150	—	°C
Overtemperature warning threshold	T _{WRN}	—	—	135	—	°C
Overtemperature warning threshold deviation	—	—	—	±10	—	°C
Low battery threshold	—	LOWBAT_TH = 00	—	3.10	—	V
		LOWBAT_TH = 01	—	3.20	—	V
		LOWBAT_TH = 10	—	3.30	—	V
		LOWBAT_TH = 11	—	3.40	—	V
Low-battery recovery threshold	—	LOWBAT_RECOV = 001	—	3.20	—	V
		LOWBAT_RECOV = 010	—	3.30	—	V
		LOWBAT_RECOV = 011	—	3.40	—	V
		LOWBAT_RECOV = 100	—	3.50	—	V
		LOWBAT_RECOV = 101–11x	—	3.60	—	V
VP undervoltage lockout threshold (VP falling)	UVLO	—	—	2	—	V
VP undervoltage lockout hysteresis	—	—	—	100	—	mV

Table 3-4. Boost Converter Characteristics

Test conditions, except where noted otherwise: VA = 1.8 V, VP = 3.6 V, VBST = 5.0 V, amp gain = 12 dB, GNDA = GNDA = 0 V, TA = +25°C, MCLK_{INT} = 6 MHz. MCLK_{INT} is explained in Section 4.13.1 and Section 7.7.

Parameters	Symbol	Test Conditions	Min	Typical	Max	Units
Boost output voltage	VBST	Boosting Bypass	VP*1.15	—	5.4	V
			—	VP	—	V
Boost output voltage tolerance	ΔVBST	No load: I _{LOAD} = 0 mA	-5	—	+5	%
Load regulation	ΔV _(Load)	3.0 V < VP < 4.2 V; I _{LOAD} = 0.25A to 1.5 A	—	60	—	mV/A
Line regulation	ΔV _(Line)	3.0 V < VP < 4.2 V; I _{LOAD} = 0 A, 500 mA	—	40	—	mV/V
Boost FET peak-current limit (See Section 7.10.)	I _{MAX(B)}	BST_IPK = 0000 0000	—	2.89	—	A
		BST_IPK = 0010 0000	—	3.30	—	A
		BST_IPK = 0100 0000	—	3.72	—	A
		BST_IPK = 0110 0000	—	4.14	—	A
		BST_IPK = 1000 0000	—	4.56	—	A
Output switching frequency ¹	f _{SW(B)}	—	—	MCLK _{INT} /3	—	MHz
Boost FET ON resistance	R _{DS(ON)B}	I _{OUT(B)} = 1 A	—	80	—	mΩ
Boost FET ON resistance temp coefficient	—	I _{OUT(B)} = 1 A	—	0.2	—	%/°C
Rectifying FET ON resistance	R _{DS(ON)R}	I _{OUT(B)} = 1 A	—	150	—	mΩ
Rectifying FET ON resistance temp coefficient	—	I _{OUT(B)} = 1 A	—	0.2	—	%/°C
Overshoot detection threshold	V _{OVT}	Boost enabled	—	5.5	5.7	V
Threshold Class G On, IN+ to IN-	V _{IN1THON}	VBST = VP = 3.6 V	—	0.60	—	V
Threshold Class G Off, IN+ to IN-	V _{IN1THOF}	VP = 3.6 V, VBST = 5 V	—	0.33	—	V
Minimum Class G boost ON hold-off time	—	VP = 3.6 V, VBST = 5 V	—	800 ²	—	ms
Operating efficiency ³	η _B	VBST = 5 V, I _{OUT(B)} = 500 mA	—	90	—	%
		VBST = 5 V, I _{OUT(B)} = 1.5 A	—	85	—	%

1. MCLK_{INT} (see p. 37) should be configured so MCLK_{INT} is 6 or 6.1440 MHz (see Table 4-14) for boost-converter operation at 2 or 2.05 MHz.
2. Minimum Class G boost ON hold-off time is determined from when the low audio detection is latched until when the boost is turned off. The latching mechanism occurs in 800-ms intervals. If the audio level is detected as low between two sequential latches, the hold-off time is extended by the difference between when the detection occurs and the subsequent latch pulse. This may extend the hold-off time up to 1.6 s in extreme cases.
3. Efficiency specified here assumes the boost converter drives an external resistive load via the VBST pin, instead of the onboard Class D amplifier.

Table 3-5. LED Drive Characteristics

Test conditions, except where noted otherwise: VA = 1.8 V, VP = 3.6 V, VBST = 5.0 V, GNDA = GNDA = GNDPLED = 0 V, TA = +25°C.

Parameters	Min	Typical	Max	Units		
Flash Mode current settings, per LED ¹ (Step size = 50 mA)	LED_FLCUR = 1111	—	750	—	mA	
	LED_FLCUR = 0001	—	50	—	mA	
Flash Inhibit Mode current settings, per LED ¹ (Step size = 50 mA)	LED_FLINHCUR = 0111	—	350	—	mA	
	LED_FLINHCUR = 0001	—	50	—	mA	
Movie Mode current settings, per LED ¹	LED_MVCUR = 111	—	150	—	mA	
	LED_MVCUR = 110	—	120	—	mA	
	LED_MVCUR = 101	—	100	—	mA	
	LED_MVCUR = 100	—	80	—	mA	
	LED_MVCUR = 011	—	60	—	mA	
	LED_MVCUR = 010	—	40	—	mA	
	LED_MVCUR = 001	—	20	—	mA	
LED current accuracy	-10	—	+10	%		
LED current matching	—	10	—	%		
Flash timer (t _{flash})	MCLK _{INT} = 6 MHz ² ; TIMER = 1 0010-1 1111	—	500	—	ms	
		TIMER = 0 0001	—	75	—	ms
		TIMER = 0 0000	—	50	—	ms
	MCLK _{INT} = 6.144 MHz; TIMER = 1 0010-1 1111	—	488.3	—	ms	
		TIMER = 0 0001	—	73.2	—	ms
		TIMER = 0 0000	—	48.8	—	ms
LED flash timer accuracy	0	—	+1	ms		
LED flash inhibit time (FLINH high to LED current 3% settling)	—	40	—	μs		

1. Flash or Movie Mode current is delivered from the boost converter's output, which provides a voltage higher than the LED voltage. Depending on the LED voltage requirement and on VP supply voltage, the boost converter is internally controlled to boost or be in bypass (rectifying FET fully on).
2. The flash time setting is generated from MCLK_{INT}. MCLK_{INT} (see p. 37) should be configured so MCLK_{INT} is 6 or 6.1440 MHz. See Table 4-14.

Table 3-6. Speaker Amplifier Output Characteristics

Test conditions, except where noted otherwise: VA = 1.8 V, VP = 3.6 V, VBST = 5.0 V, 1-kHz input, amp gain = 12 dB, GNDA = GNDD = 0 V, TA = +25°C, measurement bandwidth is 20 Hz to 20 kHz, Fs = 48 kHz, MCLK_{INT} = 6 MHz. MCLK_{INT} is explained in Section 4.13.1 and Section 7.7.

Parameters	Symbol	Test Conditions	Min	Typical	Max	Units
Continuous average power delivered to load ¹	Po	8-Ω load, THD 10%	—	1.75	—	W
		8-Ω load, THD 1%	—	1.45	—	W
THD+N	THD+N	8-Ω load, 1.0 W	—	0.02	—	%
Input voltage @ 1% THD+N	V _{CLIP}	8-Ω load	—	0.84	—	V _{rms}
Signal to noise ratio	SNR	Referenced to output voltage @1% THD+N, A-weighted	—	102	—	dB
Idle channel noise	ICN	VBST = VP, A-weighted	—	25	—	μV _{rms}
Common-mode rejection ratio	CMRR	V _{ripple} = 1 V _{PP} , f _{ripple} = 217 Hz	—	55	—	dB
Frequency response	FR	20 Hz to 20 kHz, No input DC blocking caps	-0.1	0	0.1	dB
Efficiency ²	η _A	8-Ω load 33 μH, 1.7 W	—	91	—	%
Class D amplifier gain	—	AMP_GAIN = 000 (mute)	—	-80	—	dB
		AMP_GAIN = 001	—	9	—	dB
		AMP_GAIN = 010	—	12	—	dB
		AMP_GAIN = 011	—	15	—	dB
		AMP_GAIN = 100	—	18	—	dB
N-FET ON resistance	R _{DS ON,N}	I _{FET} = 0.5 A	—	185	—	mΩ
P-FET ON resistance	R _{DS ON,P}	I _{FET} = 0.5 A	—	205	—	mΩ
Output DC offset voltage	V _{OFFSET}	Inputs AC coupled to ground	—	±5	—	mV
Time from shutdown to audio out	t _{SD}	RESET deasserted, zero-crossing disabled	—	15	—	ms

1. Power delivered to the speaker from the 0.1-Ω load side terminal (refer to Fig. 2-1).

2. Efficiency collected using a 5-V external supply, as shown in the drawing. For this test, the VBST pin should not be connected to the SPKRSUPPLY pin.

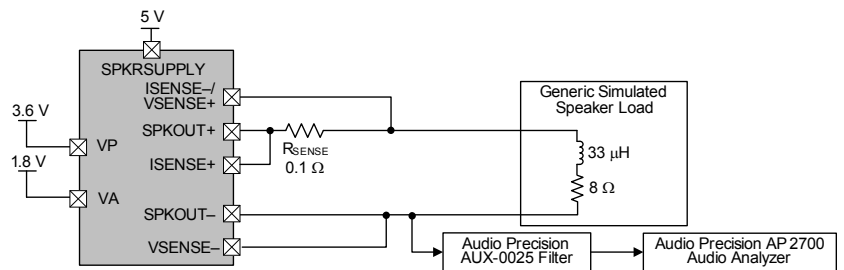
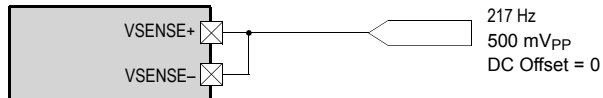

Table 3-7. Signal Monitoring Characteristics

Test conditions, except where noted otherwise: VA = 1.8 V, VP = 3.6 V, VBST = 5.0 V, amp gain = 12 dB, 0.1-Ω sense resistor, GNDA = GNPD = 0 V, TA = +25°C. Measurement bandwidth is 20 Hz to 20 kHz, Fs = 48 kHz, Input Signal = 1 kHz, MCLK_{INT} = 6 MHz, MCLK_{INT} is explained in [Section 4.13.1](#) and [Section 7.7](#).

Parameters		Min	Typical	Max	Units
General ADC characteristics	Power-up time: t _{PUP(ADC)}	—	8.5	[1]	ms
VSENSE± monitoring characteristics (VMON)	Data width	—	16	—	Bits
	Dynamic range (unweighted), VSENSE± = ±5.0 V (10 V _{PP})	—	60	—	dB ²
	Total harmonic distortion + noise, -3.8 dBFS ³	—	-60	—	dB ²
	Full-scale signal input voltage	6.59•VA	6.94•VA	7.29•VA	V _{PP}
	Common-mode rejection ratio (217 Hz @ 500 mV _{PP}) ⁴	—	60	—	dB ²
	Group delay ⁵	—	7.6/Fs	—	s
ISENSE± monitoring characteristics (IMON)	Data width	—	16	—	Bits
	Dynamic range (unweighted), ISENSE± = ±0.625 A (1.25 A _{PP})	—	56	—	dB ²
	Total harmonic distortion, -29.5 dBFS ⁶	—	-45	—	dB ²
	Full-scale signal input voltage	1.56•VA	1.64•VA	1.72•VA	V _{PP}
	VMON-to-IMON isolation ⁷	—	56	—	dB ²
	Group delay ⁸	—	7.6/Fs	—	s
VP monitoring characteristics	Data width	—	8	—	Bits
	Voltage resolution (See the equation in Section 4.8.4.)	—	35.3	—	mV
	(FF code) signal input voltage (VP)	2.89•VA	3.05•VA	3.20•VA	V
	VPMON = 1011 0011	—	2.8	—	V
	VPMON = 1011 0100	—	2.835	—	V
	VPMON = 1111 1111	—	5.482	—	V
VPMON = 0000 0000	—	5.518	—	V	

1. Typical value is specified with PDN_AMP and PDN_xMON bits initially set. Maximum power-up time is affected by the actual MCLK_{INT} frequency.
2. Parameters given in dB are referred to the applicable typical full-scale voltages. Applies to all THD+N and resolution values in the table
3. VSENSE± THD is measured with the Class D amplifier as the audio source connected to an 8-Ω + 33μH speaker load, supplied by a 6.3-V_{PP}, 1-kHz sine wave, operating under the typical performance test conditions to produce a large, unclipped audio signal. This setup produces a -3.8-dBFS VMON output. Larger Class D amplifier amplitudes begin to exhibit clipping behavior, increasing distortion of the signal supplied to VSENSE±
4. CMRR test setup for VSENSE±:



5. VMON group delay is measured from the time a signal is presented on the VSENSE± and pins until the MSB of the digitized signal exits the serial port. Fs is the LRCK rate.
6. For reference, injecting a 125-mVpp fully differential sine wave into the ISENSE± pins (equivalent to a ±0.625 A current with a 0.1-Ω ISENSE resistor) produces an IMON output of -29.5 dBFS (since typical full-scale is 1.64•VA, in V_{PP}). ISENSE± monitoring THD is measured using the Class D amplifier as the audio source, which is connected to an 8-Ω + 33-μH speaker load, supplied by a 7.0-V_{PP}, 1-kHz sine wave, operating under the typical performance test conditions to produce a large, unclipped audio signal. This setup produces a -29.5-dBFS amplitude IMON output. Larger Class D amplifier amplitudes begin to exhibit clipping behavior, increasing the distortion of the signal supplied to ISENSE±.
7. VMON-to-IMON isolation is the error in the current sense due to VMON, expressed relative to full-scale sense current in decibels.
8. IMON group delay is measured from when a signal is presented on the ISENSE± pins until the MSB of the digitized signal exits the serial port. Fs is the LRCK rate.

Table 3-8. Digital Interface Specifications and Characteristics

Test conditions, except where noted otherwise: VA = 1.8 V, VP = 3.6 V, VBST = 5.0 V, GNDA = GNPD = 0 V, TA = +25°C.

Parameters	Symbol	Test Conditions	Min	Max	Units
Input leakage current (per pin) ^{1,2}	FLOUT2/AD0	—	—	±7.5	μA
	FLEN, FLINH, LRCK	—	—	±4.5	μA
	MCLK, SCLK, SDOOUT	—	—	±4.5	μA
	SCL, SDA, INT, RESET	—	—	±0.1	μA
Input capacitance	I _{IN}	—	—	10	pF
VA logic I/Os	High-level output voltage	I _{OH} = -67/-100 μA ³	VA-0.2	—	V
	Low-level output voltage	All outputs, I _{OL} = 67/100 μA ³ INT, SDA, I _{OL} = 3 mA	—	0.20	V
	High-level input voltage	—	0.70•VA	—	V
	Low-level input voltage	—	—	0.30•VA	V

1. Specification includes current through internal pull up/down resistors, where applicable (as defined in [Section 1](#)).
2. Leakage current is measured with VA = 1.80 V, VP = 3.60 V, VBST = 3.60 V, and RESET asserted. Each pin is tested while driven high and low.
3. For the ADSP output SDOOUT and potential outputs SCLK and LRCK (if M/S = 1), if ADSP_DRIVE = 0 see [Section 7.13](#), I_{OH} and I_{OL} are -100 and +100 μA. If ADSP_DRIVE = 1, I_{OH} and I_{OL} are -67 and +67 μA. For other, non-ADSP_DRIVE-affected outputs, I_{OH} and I_{OL} are -100 and +100 μA.

Table 3-9. PSRR Characteristics

 Test conditions, except where noted otherwise: $V_A = 1.8\text{ V}$, $V_P = 3.6\text{ V}$, $V_{BST} = V_P$, amp gain = 12 dB, $G_{NDA} = G_{NDP} = 0\text{ V}$, $T_A = +25^\circ\text{C}$.

Parameters	Conditions	Noise Injected Into	Noise Measured On	Noise Amplitude (mV)	Noise Frequency (Hz)	Min	Typical	Max	Units	
Speaker amplifier PSRR	$V_{BST} = V_P$	VA	SPKOUT±	100	217	—	75	—	dB	
					1k	—	75	—	dB	
					20k	—	70	—	dB	
		VP	SPKOUT±	100	217	—	70	—	—	dB
					1k	—	70	—	dB	
					20k	—	55	—	dB	
VPMON PSRR	$V_{BST} = V_P$	VA	SDOUT	100	217	—	36	—	dB	
					1k	—	36	—	dB	
					20k	—	33	—	dB	
VSENSE± PSRR ¹	$V_{BST} = V_P$	VA	SDOUT	100	217	—	60	—	dB	
					1k	—	60	—	dB	
					20k	—	50	—	dB	
ISENSE± PSRR	$V_{BST} = V_P$	VA	SDOUT	100	217	—	60	—	dB	
					1k	—	60	—	dB	
					20k	—	60	—	dB	

1. The speaker voltage monitor has a lower PSRR because its input path has an attenuation of 16.6 dB. The PSRR specification is referred to the input signal and, as such, includes the loss of 16.6 dB.

Table 3-10. Power Consumption

 Test conditions, except where noted otherwise: $V_A = 1.8\text{ V}$, $V_P = 3.6\text{ V}$, $V_{BST} = V_P$, $G_{NDA} = G_{NDP} = 0\text{ V}$, $T_A = +25^\circ\text{C}$.

Use Configuration		Typical Current			
		i_{VP}	i_{VA}	Units	
Powered up (PDN_BST = 00)	RESET asserted, MCLK, SCLK, LRCK inactive	1	1	μA	
	IN+ IN– shorted to ground, LEDs off, monitors powered down ¹	No C _{OUT}	3270	390	μA
	IN+ IN– shorted to ground, LEDs off, monitors powered down ¹	C _{OUT} = 470 pF (See Fig. 2-1)	4275	390	μA
	IN+ IN– shorted to ground, LEDs off, monitors powered up ¹	No C _{OUT}	3360	1435	μA
	IN+ IN– shorted to ground, LEDs off, monitors powered up ¹	C _{OUT} = 470 pF See Fig. 2-1)	4360	1435	μA
Boost Mode bypass (PDN_BST = 01)	RESET asserted, MCLK, SCLK, LRCK inactive	1	1	μA	
	IN+ IN– shorted to ground, LEDs off, monitors powered down ¹	No C _{OUT}	1983	390	μA
	IN+ IN– shorted to ground, LEDs off, monitors powered down ¹	C _{OUT} = 470 pF (See Fig. 2-1)	3093	390	μA
	IN+ IN– shorted to ground, LEDs off, monitors powered up ¹	No C _{OUT}	2074	1435	μA
	IN+ IN– shorted to ground, LEDs off, monitors powered up ¹	C _{OUT} = 470 pF See Fig. 2-1)	3185	1435	μA

1. Refer to Section 7.6 for configuring monitor power down

Table 3-11. Switching Specifications: Power, Reset, Master Clocks

 Test conditions, except where noted otherwise: $V_A = 1.8\text{ V}$, $V_P = 3.6\text{ V}$, $V_{BST} = 5.0\text{ V}$, $T_A = +25^\circ\text{C}$, $G_{NDA} = G_{NDP} = 0\text{ V}$. Fig. 2-1 shows typical connections; $G_{NDA} = G_{NDP} = 0\text{ V}$. Section 9 describes some parameters in detail; input timings are measured at V_{IL} and V_{IH} thresholds; output timings are measured at V_{OL} and V_{OH} thresholds (see Table 3-8).

Parameters	Symbol ¹	Min	Max	Units	
Power supplies ²	Power supply ramp up/down	$t_{PWR-RUD}$	—	100	ms
Reset ²	RESET low (logic 0) pulse width	t_{RLPW}	1	—	ms
	RESET hold time after power supplies ramp up	$t_{RH(PWR-RH)}$	1	—	ms
	RESET setup time before power supplies ramp down	$t_{RS(RL-PWR)}$	1	—	ms
	RESET rising edge to control-port active	t_{IRS}	[3]	—	ns
Master clocks	MCLK frequency ⁴	f_{MCLK}	—	12.3	MHz
	MCLK duty cycle	D_{MCLK}	45	55	%

1. Power and reset sequencing

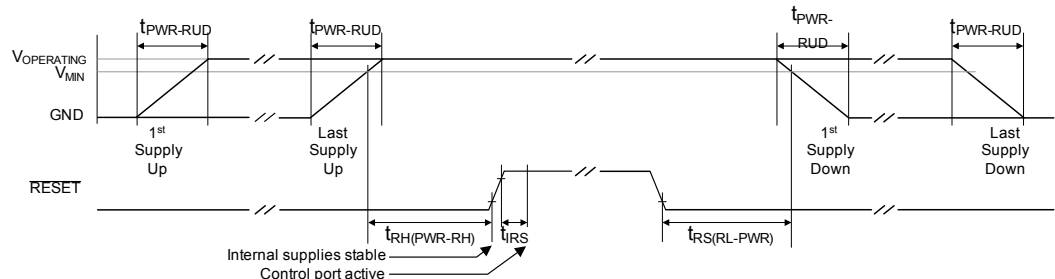

2. VP supply may be applied or removed independently of RESET and the other power rails. See Section 4.1 for additional details.

 3. The RESET rising-edge-to-control-port-active timing, t_{IRS} , is specified in Table 3-13.

4. Maximum frequency for highest supported nominal rate is indicated. The supported nominal serial port sample rates are found in Section 4.11.2.

Table 3-12. Switching Specifications: ADSP in I²S Mode

Test conditions, except where noted otherwise: VA = 1.8 V, VP = 3.6 V, VBST = 5.0 V, TA = +25°C, Inputs: Logic 0 = GNDA = GNDP = 0 V, Logic 1 = VA; CLOAD = 30 pF. Section 9 describes some parameters in detail; input timings are measured at VIL and VIH thresholds; output timings are measured at VOL and VOH thresholds (see Table 3-8).

Parameters		Symbol ¹	Min	Max	Units	
Slave Mode	Input sample rate (LRCK) ²	Fs	—	49	kHz	
	LRCK duty cycle	—	45	55	%	
	SCLK frequency	1/t _{Ps}	—	64•Fs	Hz	
	SCLK duty cycle	—	45	55	%	
	LRCK setup time before SCLK rising edge	t _{SS(LK-SK)}	40	—	ns	
	LRCK hold time after SCLK rising edge	t _{HS(SK-LK)}	20	—	ns	
	SDOUT time from SCLK to data valid start ³	t _{DataValidStrt}	—	300	ns	
	SDOUT time from SCLK to data valid end ³	t _{DataValidEnd}	155	—	ns	
Master Mode	OUTPUT sample rate (LRCK) ⁴	Fs	—	[4]	kHz	
	LRCK duty cycle	—	45	55	%	
	SCLK frequency	1/t _{PM}	—	64•Fs	Hz	
	SCLK duty cycle	RATIO = 0	—	45	55	%
		RATIO = 1 [5]	—	33	67	%
	LRCK setup time before SCLK rising edge	t _{SM(LK-SK)}	35	—	ns	
	LRCK hold time after SCLK rising edge	t _{HM(SK-LK)}	20	—	ns	
	SDOUT time from SCLK to data valid start ³	t _{DataValidStrt}	—	300	ns	
	SDOUT time from SCLK to data valid end ³	t _{DataValidEnd}	155	—	ns	

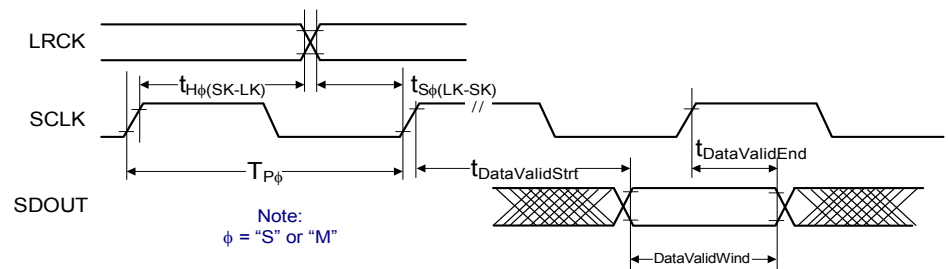
 1. ADSP timing in I²S Mode

2. Clock rates should be stable when the CS35L32 is powered up.

3. Minimum data valid window, as shown in signal diagram, is (SCLKperiod – 300 + 155) ns. For SCLK = 64•Fs = 64•48 = 3072 kHz, this is 180 ns.

4. In Master Mode, the output sample rate follows MCLK rate divided down per Table 4-14 and Section 7.7. Any deviation in internal MCLK from the nominal supported rates is directly imparted to the output sample rate by the same factor (e.g., +100-ppm offset in the frequency of MCLK becomes a +100-ppm offset in LRCK).

5. If RATIO = 1, the MCLK(INT)-to-LRCK ratio is 125. The device periodically extends SCLK high time to compensate for a fractional MCLK/SCLK ratio

Table 3-13. Switching Specifications: I²C Control Port

Test conditions, except where noted otherwise: $V_A = 1.8\text{ V}$, $V_P = 3.6\text{ V}$, $V_{BST} = 5.0\text{ V}$, $T_A = +25^\circ\text{C}$, Inputs: Logic 0 = $G_{NDA} = G_{NDP} = 0\text{ V}$, Logic 1 = V_A ; SDA load capacitance equal to maximum value of C_B specified below; minimum SDA pull-up resistance, $R_{P(\min)}$.¹ Section 9 describes some parameters in detail. All specifications are valid for the signals at the pins of the CS35L32 with the specified load capacitance; input timings are measured at V_{IL} and V_{IH} thresholds; output timings are measured at V_{OL} and V_{OH} thresholds (see Table 3-8).

Parameter	Symbol ²	Min	Max	Units
RESET rising edge to start	t_{IRS}	500	—	ns
SCL clock frequency	f_{SCL}	—	400	kHz
Start condition hold time (before first clock pulse)	t_{HDST}	0.6	—	μs
Clock low time	t_{LOW}	1.3	—	μs
Clock high time	t_{HIGH}	0.6	—	μs
Setup time for repeated start condition	t_{SUST}	0.6	—	μs
SDA input hold time from SCL falling ³	t_{HDDI}	0	0.9	μs
SDA output hold time from SCL falling	t_{HDDO}	0.2	0.9	μs
SDA setup time to SCL rising	t_{SUD}	100	—	ns
Rise time of SCL and SDA	t_{RC}	—	300	ns
Fall time of SCL and SDA	t_{FC}	—	300	ns
Setup time for stop condition	t_{SUSP}	0.6	—	μs
Bus free time between transmissions	t_{BUF}	1.3	—	μs
SDA bus capacitance	C_B	—	400	pF

1. The minimum R_P and R_{P_1} values (resistors shown in Fig. 2-1) are determined using the maximum level of V_A , the minimum sink current strength of their respective output, and the maximum low-level output voltage V_{OL} (specified in Table 3-8). The maximum R_P and R_{P_1} values may be determined by how fast their associated signals must transition (e.g., the lower the value of R_P , the faster the I²C bus is able to operate for a given bus load capacitance). See the I²C switching specifications in Table 3-13 and the I²C bus specification referenced in Section 13.

2. I²C control-port timing.

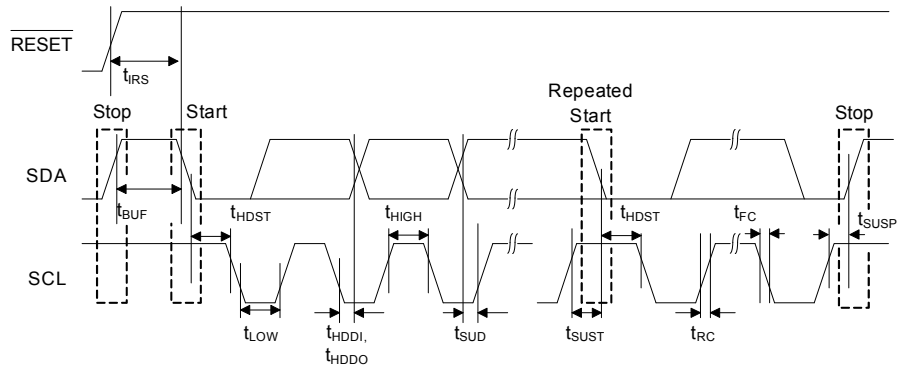

3. Data must be held long enough to bridge the transition time, t_F , of SCL.

4 Functional Description

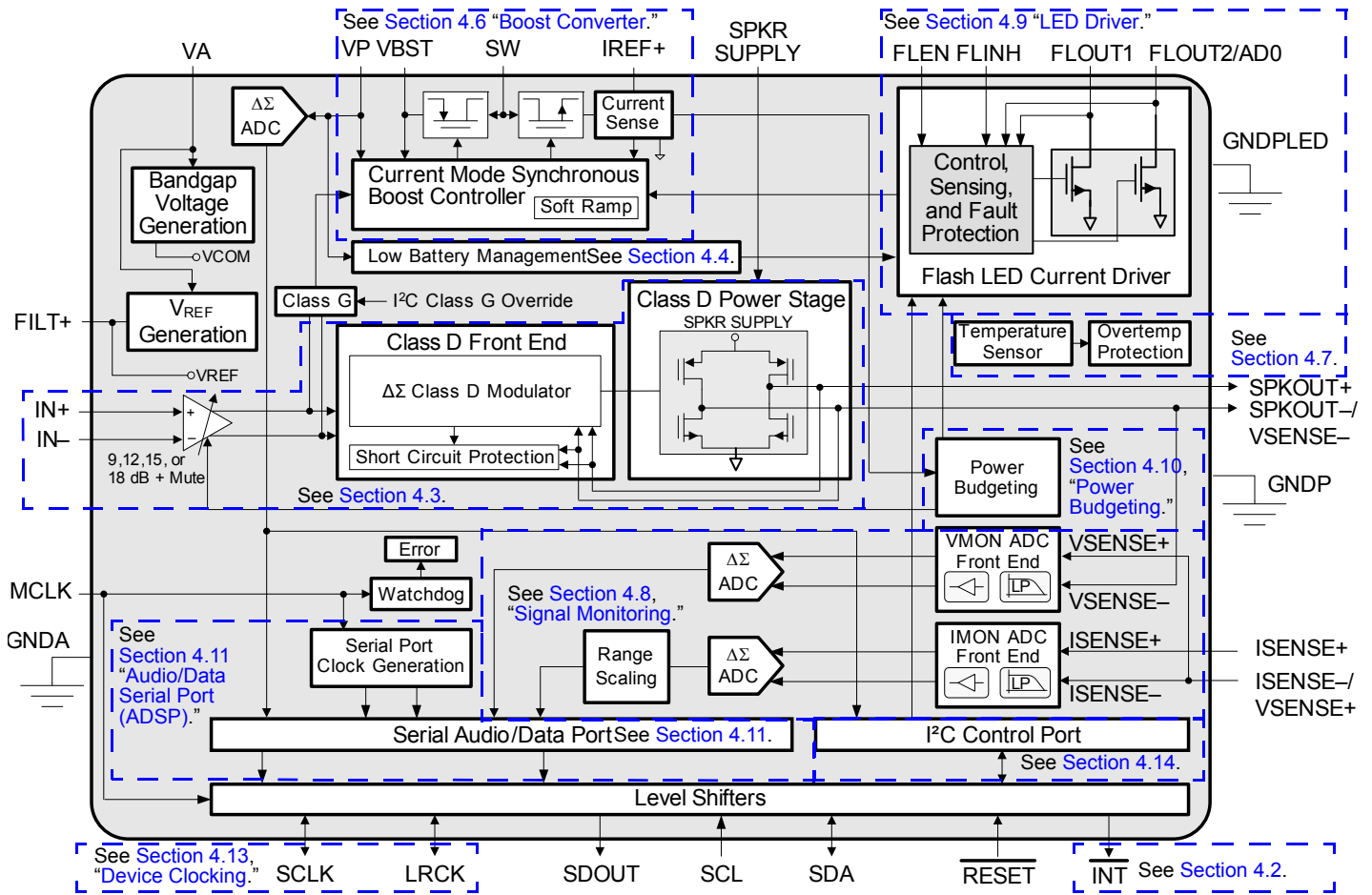

Figure 4-1. CS35L32 Block Diagram

4.1 Power Supplies

The VA and VP supplies are required for proper operation of the CS35L32. Before either supply is powered down, $\overline{\text{RESET}}$ must be asserted. $\overline{\text{RESET}}$ must be held in the asserted state until all supplies are up and within the recommended range. Timing requirement for $\overline{\text{RESET}}$ during supply power up and power down is described in Table 3-11. The VBST supply is generated internally (as described in Section 7.12) and connected to the high-power output stage of the Class D amplifier through two balls: VBST and SPKRSUPPLY. By so doing, the speaker amplifier benefits from the proximity of the external decoupling capacitor that is connected to the boosted supply.

4.2 Interrupts

Events that require special attention, such as when a threshold is exceeded or an error occurs, are reported through the assertion of the interrupt output pin, $\overline{\text{INT}}$. These events are captured within the interrupt status registers. Events can be individually masked by setting corresponding bits in the interrupt mask registers. Table 4-1 lists interrupt status and mask registers. The configuration of mask bits determines which events cause the immediate assertion of $\overline{\text{INT}}$:

- When an unmasked interrupt status event is detected, the status bit is set and $\overline{\text{INT}}$ is asserted.
- When a masked interrupt status event is detected, the interrupt status bit is set, but $\overline{\text{INT}}$ is not affected.

Once $\overline{\text{INT}}$ is asserted, it remains asserted until all unmasked status bits that are set have been read. Interrupt status bits are sticky and read-to-clear: Once set, they remain set until the register is read and the associated interrupt condition is not present. If a condition is still present and the status bit is read, although $\overline{\text{INT}}$ is deasserted, the status bit remains set.

To clear any status bits set due to the initiation of a path or block, all interrupt status bits should be read after reset and before normal operation begins. Otherwise, unmasking these previously set status bits causes `INT` to assert.

Table 4-1. Interrupt Status Registers and Corresponding Mask Registers

Status Registers	Mask Registers
Interrupt Status 1 (Audio) (Section 7.19)	Interrupt Mask 1 (Section 7.16)
Interrupt Status 2 (Monitors) (Section 7.20)	Interrupt Mask 2 (Section 7.17)
Interrupt Status 3 (LEDs and Boost Converter) (Section 7.21)	Interrupt Mask 3 (Section 7.18)

4.3 Speaker Amplifier

The CS35L32 features a high-efficiency mono Class D audio amplifier, shown in Fig. 4-2, with an advanced closed-loop architecture that achieves low levels of output distortion. Automatic Class G operation, using a boosted supply to the amplifier, allows louder speaker performance with high crest factor.

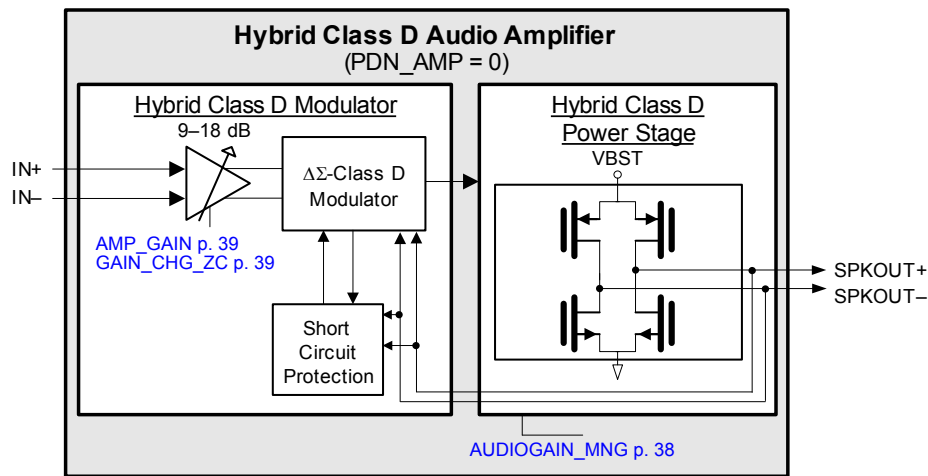

Figure 4-2. Speaker Amplifier Block Diagram

4.3.1 Class G Operation with LEDs Off

The boost converter output is the supply to the speaker amplifier. Audio operation can be programmed to have one of the following supply modes (See Section 7.12 for programming details.):

- Class G where the boost converter is in Bypass Mode for audio input signals below a threshold $V_{IN1THON}$ and in 5-V Boost Mode for audio signal inputs above a threshold $V_{IN1THOFF}$. These thresholds are specified in Table 3-4 for the given conditions. The corresponding equations are shown below.
- Class G disabled, boost converter is in Bypass Mode, and $VBST = VP$. In this mode, thresholds are ignored.
- Class G disabled, boost converter is in Boost Mode, and $VBST = 5\text{ V}$. In this mode, thresholds are ignored.

The Class G equations for the audio input signal thresholds are as follows:

$$V_{IN1THOF} = \left(\frac{4}{15}K\right) \times \left(\frac{VBST}{Gain}\right)$$

and

$$V_{IN1THON} = \left(\frac{2}{3}K\right) \times \left(\frac{VBST}{Gain}\right)$$

$VBST$ is the boost converter output voltage (whether in Bypass or Boost Mode), and gain is audio gain expressed as a unitless real ratio (nonlogarithmic). $K = 1$ if $MCLK$ is 6 or 12 MHz; $K = 1.024$ if $MCLK$ is 6.144 or 12.288 MHz. $MCLK_{INT}$ should be configured as described in Section 4.13.1 and Section 7.7.

4.3.2 Class G Operation with LEDs On

If LEDs are active, the speaker amplifier supply in one of the following supply modes, as specified by VBOOST_MNG (see [Section 4.10.3](#) and [Section 7.12](#) for details):

- Class G operation defaults to the higher supply setting: that requested by the LEDs or that requested by Class G. The latter takes into account both thresholds $V_{IN1THOF}$ and $V_{IN1THON}$, as described in [Section 4.3.1](#).
- Class G disabled and the speaker amplifier supply is set as requested by the LEDs. Thresholds are ignored.
- Class G disabled where the boost converter is in Bypass Mode ($VBST = VP$). Thresholds are ignored.
- Class G disabled where the boost converter is in Boost Mode and $VBST = 5\text{ V}$. Thresholds are ignored.

4.3.3 Error Conditions

[Table 4-2](#) provides links to error status and mask bits for the Class D audio amplifier errors.

Table 4-2. Class D Audio Amplifier Error Status and Mask Bits

Error	Cross-Reference to Description
Amplifier short/Amplifier short mask	AMP_SHORT p. 41, M_AMP_SHORT p. 40, also see Section 4.3.3
Amplifier short release	AMP_SHORT_RLS p. 39
Overtemperature error/Overtemperature error mask	OTE p. 41, M_OTE p. 40, also see Section 4.3.3
Overtemperature error release	OTE_RLS p. 40

The CS35L32 monitors the OUT_{\pm} terminals in real time to determine whether the output voltage signal correlates to the PWM data stream driving the gate drivers internal to the device. If it is not, the CS35L32 interprets the discrepancy as a short on the outputs, which may have been caused by a short to ground, across the speaker, or to the VBST rail.

If this error occurs, the AMP_SHORT status bit is set, and, if $M_AMP_SHORT = 0$, \overline{INT} is asserted. As a result, the device enters Speaker-Safe Mode, which is described in [Section 4.3.4](#).

The CS35L32 also enters Speaker-Safe Mode if its temperature exceeds the overtemperature shutdown threshold specified in [Table 3-3](#). The OTE status bit is set; if $M_OTE = 0$, \overline{INT} is asserted.

The amplifier shuts down automatically due to battery (VP) undervoltage, as described in [Section 4.5](#). The amplifier restarts automatically upon voltage recovery, with default gain.

The audio amplifier outputs are clamped to ground if MCLK stops, as described in [Section 4.13.3](#).

4.3.4 Speaker-Safe Mode

Speaker-Safe Mode is entered according to the AMP_SHORT and OTE interrupt status bits as follows:

- In the event of an AMP_SHORT, the CS35L32 mutes the amplifier output to Hi-Z to protect the speaker while the boost converter is allowed to operate normally.
- In the event of an OTE, the CS35L32 mutes the amplifier output to Hi-Z to protect the speaker and sets the boost converter in Bypass Mode ($VBST = VP$). Normal behavior resumes when the error condition ceases and OTE_RLS is sequenced as described in [Section 4.7.1](#).
- If Speaker-Safe Mode is entered as a result of an AMP_SHORT error, normal behavior resumes when the short condition ceases and the AMP_SHORT_RLS bit is sequenced as described in [Section 7.15](#).

4.4 Low-Battery Management

Under heavy current loading, such as a high current LED flash event, the battery voltage drops. LOWBAT_TH (see [p. 37](#)) allows the user to select a voltage threshold, below which flash current is reduced from the LED_FLCUR setting (see [p. 43](#)) to the LED_FLINHCUR setting (see [p. 44](#)). Upon voltage recovery above LOWBAT_RECOV (see [p. 37](#)), the flash current setting reverts to normal. The user should select a recovery threshold higher than the low-battery threshold.

Low-Battery Mode is entered only if a battery voltage falls below the programmed LOWBAT_TH during a flash event. This condition is reported by the setting LOWBAT (see [p. 42](#)), which can be masked with M_LOWBAT (see [p. 41](#)).

\overline{INT} is deasserted after the interrupt registers are cleared by being read, provided the condition no longer exists.

4.5 Undervoltage Lockout (UVLO)

If the VP level falls below the lockout threshold specified in [Table 3-3](#), UVLO protection shuts down all analog circuitry of the CS35L32. Autorecovery occurs as VP rises above the lockout threshold by a voltage equal to the specified hysteresis. During a UVLO condition, control port, UVLO detection, serial clock, watchdog, and thermal detection circuitry stay active.

Note: During an UVLO condition, the I²S port is automatically powered down, preventing the UVLO condition from being fed back via the ADSP SDOOUT pin.

4.6 Boost Converter

The CS35L32's boost converter, shown in [Fig. 4-3](#), delivers power to the supply of the audio speaker amplifier as well as to the LEDs. Its output voltage is determined by `VBOOST_MNG` (see [p. 38](#)). [Section 4.10](#) further shows how `VBOOST_MNG` relates to audio and LED operation. The boost converter features a current-limiting circuit that detects and clamps peak inductor current if such a peak is equal to the user-programmable limit (`BST_IPK`, see [p. 38](#)). `BOOST_CURLIM` interrupt flag is set when the current limit has been detected.

`MCLKINT` sets the frequency of the converter to 2 MHz. `MCLKINT` is derived from `MCLK` by setting `MCLKDIV2` (see [p. 37](#)). If `MCLKINT` stops switching, the converter is placed in Bypass Mode until clocking is restored.

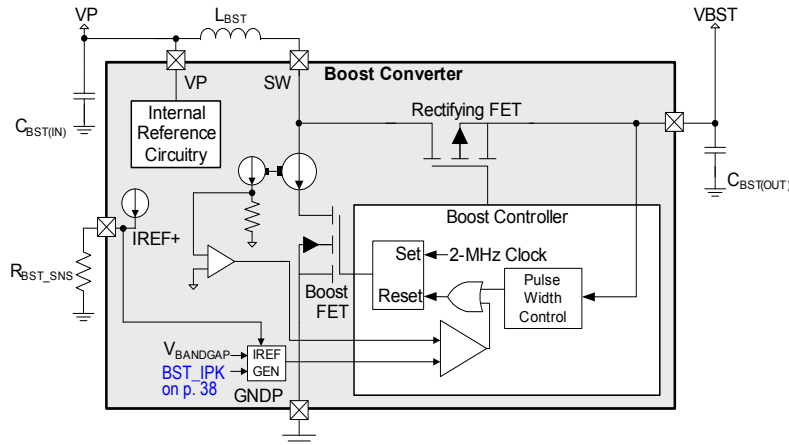

Figure 4-3. Boost Controller Block Diagram

4.7 Die Temperature Monitoring

Onboard die temperature monitoring prevents, shown in [Fig. 4-4](#), the CS35L32 from reaching a temperature that would compromise reliability or functionality. The CS35L32 incorporates a two-threshold thermal-monitoring system. When die temperature exceeds the lower threshold, an overtemperature warning (OTW) event occurs; if it exceeds the second threshold, an overtemperature error (OTE) condition occurs. These conditions are described in [Section 4.7.1](#).

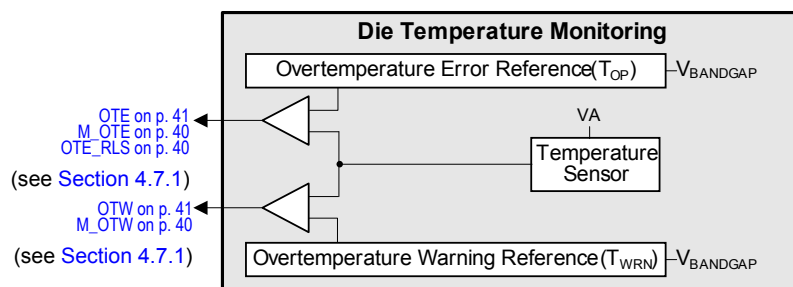

Figure 4-4. Die Temperature Monitoring

Note: The CS35L32 does not support independent powering down of die-temperature monitoring circuitry (other than powering it down via `PDN_ALL`, see [p. 36](#)).

4.7.1 Error Conditions

Table 4-3 lists overtemperature error status and mask bits.

Table 4-3. Die Temperature Monitoring Configuration

Error	Cross-Reference to Register Field Description
Overtemperature error/Overtemperature error mask	OTE p. 41/M_OTW p. 40
Overtemperature warning/Overtemperature warning mask	OTW p. 41/M_OTW p. 40
Overtemperature error release	OTE_RLS p. 40

The overtemperature error and warning error conditions are described in detail in the following:

- Overtemperature warning (OTW). An OTW event occurs when the die temperature exceeds the overtemperature threshold (listed in Table 3-3). When this occurs, an OTW (see p. 41) event is registered in the interrupt status (Section 7.19); if M_OTW = 0, INT is asserted.
To exit the condition, the temperature must drop below the threshold and interrupt status 1 register must be read.
- Overtemperature error (OTE). An OTE event occurs when the die temperature exceeds the internally preset error threshold (see Table 3-3). When this occurs, an OTE (see p. 41) event is registered in the interrupt status and, if M_OTW = 0, INT is asserted. The CS35L32 shuts down, the Class D amplifier enters Speaker Safe Mode, as described in Section 4.3.4, and the LED drivers shut down.
To exit, the temperature must drop below the overtemperature shutdown threshold and OTE_RLS must be sequenced as described in Section 7.15. After OTE release, the amplifier and LED drivers recover to preshutdown settings. The LED drivers must be retrigged with FLEN and/or FLINH inputs for a lighting event to occur.

4.8 Signal Monitoring

Signal-monitoring ADCs, shown in Fig. 4-5, give upstream system processors access to important signals entering and exiting the device. The three monitoring signals are as follows:

- VPMON: Monitors the voltage on the VP pin, which is most commonly the battery for the system.
- VMON: Monitors the output voltage of the Class D amplifier.
- IMON: Monitors the current that flows into the load being driven by the Class D amplifier.

An integrated ADC digitizes these analog signals, at which point, the audio/data serial port (ADSP) can send them to the system processor.

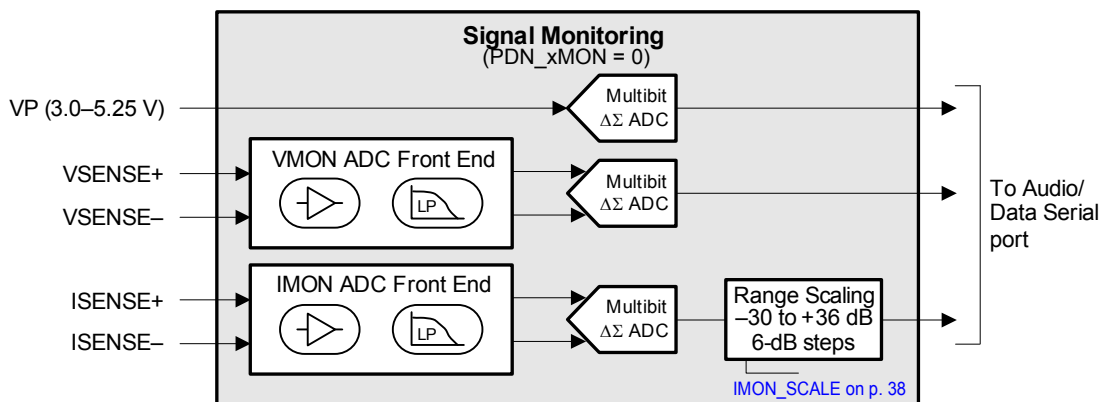

Figure 4-5. Signal Monitoring Block Diagram (PDN_xMON = 0)

4.8.1 Power-Up and Power-Down Bits (PDN_xMON)

The three ADCs can be powered down independently via their respective PDN_xMON bit in the control port, see Section 7.6. To power down an ADC and its associated support circuitry, its PDN_xMON bit must be set; clearing PDN_xMON powers up the corresponding circuitry.

Note: For proper operation, MCLK must be at the correct frequency (MCLK_ERR = 0; see p. 41) and the device must be powered (PDN_ALL = 0; see p. 36).

4.8.2 Monitoring Voltage across the Load—VMON

As shown in Fig. 4-5, monitoring on VMON is accomplished via the VSENSE± pins. Table 3-7 gives operating and performance specifications for this ADC path. The following equation determines the VMON voltage (in Volts):

$$VMON = \left(\frac{D_{OUT}}{2^{15} - 1} \right) \times \left(\frac{6.25 \times VA}{1.8} \right)$$

D_{OUT} is the 16-bit digital output monitoring word in signed decimal format (–32,768 to +32,767) and VA is the voltage on the VA pin. Relative to VSENSE+, negative D_{OUT} values equate to a negative load voltage and positive D_{OUT} values equate to a positive load voltage. When VA is 1.8 V, the full-scale signal is 6.25 V.

If VMON is a 12-bit word, its equivalent 16-bit representation for the computational purposes of this section positions the 12 bits in the 12 MSBs and the 4 LSBs are cleared in the computation.

4.8.3 Monitoring Current through the Load—IMON

As shown in Fig. 4-5, monitoring of output current is accomplished via the ISENSE± pins, which are provided to measure a voltage drop across a sense resistor in the output path, as described in Section 3. A precision resistor ($\leq 1\%$) is chosen for high accuracy when calculating the current from the voltage measured across the resistor. Likewise, to avoid thermal drift, the resistor is chosen to have a low thermal coefficient of 100 ppm/°C. Table 3-7 gives operating and performance specifications for this ADC path.

The following equation determines the IMON current (in Amps) when using a 0.1-Ω sense resistor:

$$IMON = \left(\frac{D_{OUT}}{2^{15} - 1} \right) \times \left(\frac{0.82 \times VA}{0.1\Omega} \right)$$

D_{OUT} is the 16-bit digital output monitoring word in signed decimal format (–32,768 to +32,767) and VA is the voltage on the VA pin. Relative to ISENSE+, negative D_{OUT} values equate to a negative current and positive D_{OUT} values equate to a positive current. The default IMON_SCALE, as described in Section 4.8.3.1, is used for the example equation. If the IMON_SCALE value is increased by 1 bit, the 2^{15} power in the IMON equation increases to 2^{15+1} . If the IMON_SCALE value is decreased by 1 bit, the 2^{15} power in the IMON equation decreases to 2^{15-1} .

If IMON is a 12-bit word, its equivalent 16-bit representation for the computational purposes of this section positions the 12 bits in the 12 MSBs, and the 4 LSBs are cleared in the computation.

4.8.3.1 IMON Signal Scaling (IMON_SCALE)

Because the voltage is measured across a resistor of very small value and because output current can vary significantly depending on the program material, a gain-scaling block (shown in Fig. 4-5) is included to improve the reported sample resolution for low-level signals. This control, configured through IMON_SCALE (see p. 38), allows the system processor to determine the range of bits to be received from the available 26-bit word on the IMON ADC's data bus. The default IMON_SCALE configuration (22 down to 7) configures the ADC data MSB (bit 22) to be the 16-bit IMON data packet MSB. ADC bits 23–25 allow the signal to be divided down.

If IMON is a 12-bit word, its equivalent 16-bit representation for the computational purposes of this section positions the 12 bits in the 12 MSBs. The 4 LSBs are cleared in the computation.

4.8.3.2 IMON Sense Resistor

A 0.1-Ω sense resistor is used to generate a differential voltage that is captured by the IMON circuitry to monitor the load current. If PWM output filtering components, such as ferrite beads, are placed in series with the output load, the sense resistor must be placed between the SPKOUT+ pin and the external series filter component, minimizing any performance effects produced by the output filter. If the sense resistor is placed after the series-filtering component, the signal being measured across the sense resistor will have been altered from its expected form.

4.8.4 Monitoring Voltage on the VP Pin—VPMON

Monitoring of the voltage present on the VP pin is integrated internally to the CS35L32. The operating specifications for this ADC path are given in [Table 3-7](#). To determine the voltage present on VP, the following equation must be used:

$$VP = \left(\frac{D_{OUT} + 128}{255} \times 5 + \frac{1}{1.8} \right) \times VA$$

D_{OUT} is the digital output word (see [VPMON](#), p. 38) in signed decimal format (–128 to +127), and VA is the voltage on the VA pin. If $VA = 1.8$ V, VPMON can report values from 2.8 V ($D_{OUT} = -77$ decimal) to 5.52 V ($D_{OUT} = 0$ decimal).

4.8.5 Data Transmission out of the CS35L32

The ADSP, described in [Section 4.11](#), can transmit all signals monitored in the CS35L32 to the system processor. The data is presented on these outputs simultaneously.

4.8.6 Error Conditions

The CS35L32 monitors each monitoring ADC for overflow conditions. [Table 4-4](#) lists signal monitoring error conditions and provides links to their associated register field descriptions.

Table 4-4. Signal Monitoring Error Status Conditions

Error	Cross-Reference to Description
xMON overflow. Indicates the overrange status in the VMON, IMON, or VPMON ADC signal paths.	VMON_OVFL p. 42 IMON_OVFL p. 42 VPMON_OVFL p. 42

If an overflow occurs, the appropriate xMON_OVFL bit is set, and, if the respective mask bit is cleared, an interrupt occurs. Exiting the error occurs when the signal is no longer overflowing. No release bit needs to be toggled.

- Overflow for VPMON and VMON signals. Due to the analog prescaling applied to the analog input signals, which are sampled to make the VPMON and VMON signals, overflow conditions are unlikely on these ADCs. This is because the operating specifications for maximum and minimum voltage constrain the voltage on these pins to a level far below that required to make the ADC overflow.

For VPMON, because a spurious overflow error can occur when the block is taken out of power down, it is advised to read the error status registers after PDN_xMON has been cleared to clear the spurious error status bit.

- Overflow for the IMON signal. As [Section 4.8.3.1](#) describes, the [IMON_SCALE](#) (see p. 38) control allows the greatest possible sample resolution over a wide range of output currents and sense resistors. If IMON_SCALE is set too low for either the output current being monitored or the sense resistor being used, overflow of this ADC can occur. When this error occurs, increasing the IMON_SCALE value can prevent the sampled signal from overflowing.

4.9 LED Driver

The CS35L32 includes a high-current flash LED driver (see [Fig. 4-6](#)), featuring two channels, FLOUT1 and FLOUT2, and a boost converter and current regulator designed to power LEDs with up to 0.75 A per channel. Both channels can be combined to drive an LED with 1.5 A by tying FLOUT1 and FLOUT2 together.

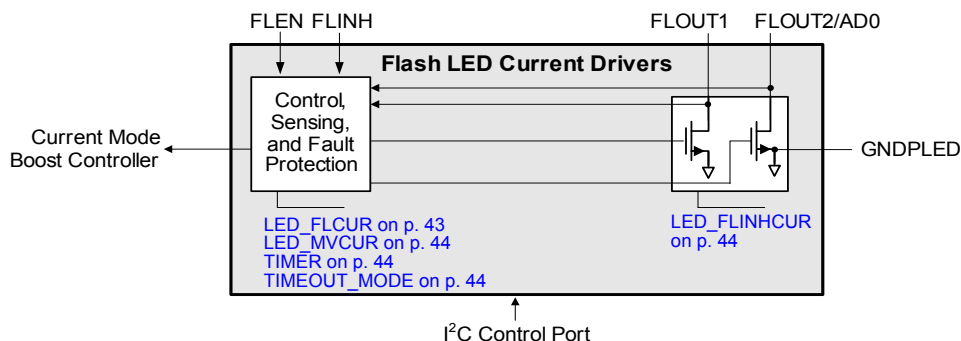

Figure 4-6. LED Driver Block Diagram

The CS35L32 is driven to flash when FLEN is asserted high. The I²C interface allows a host to program Flash and Movie Mode currents, as well as a flash timer. The corresponding registers for these settings are [LED_FLCUR](#) (see p. 43), [LED_MVCUR](#) (see p. 44), and [TIMER](#) (see p. 44). The flash event terminates at the end of a period determined by the flash timer and optionally when FLEN is deasserted; this option is configured through [TIMEOUT_MODE](#) (see p. 44).

Flash current is reduced if FLINH is asserted. Currents in both channels are reduced to the [LED_FLINHCUR](#) setting (see p. 44). If FLINH is deasserted, the current reverts to the LED_FLCUR setting, subject to the flash timer state.

Movie Mode operation has no timer and starts and ends according to the LED_MVCUR setting. [Fig. 4-7](#) shows how Flash and Flash Inhibit Mode currents are started and terminated.

To power the LED load, the LED driver and current regulator automatically boost the voltage if battery operation is insufficient to produce the required LED currents. The controller bases whether to boost or operate in bypass, based on maintaining a minimum voltage across the current regulator. The boost voltage varies by up to 5 V nominal, as described in [Section 4.10](#) and [Section 7.12](#), depending on user selection.

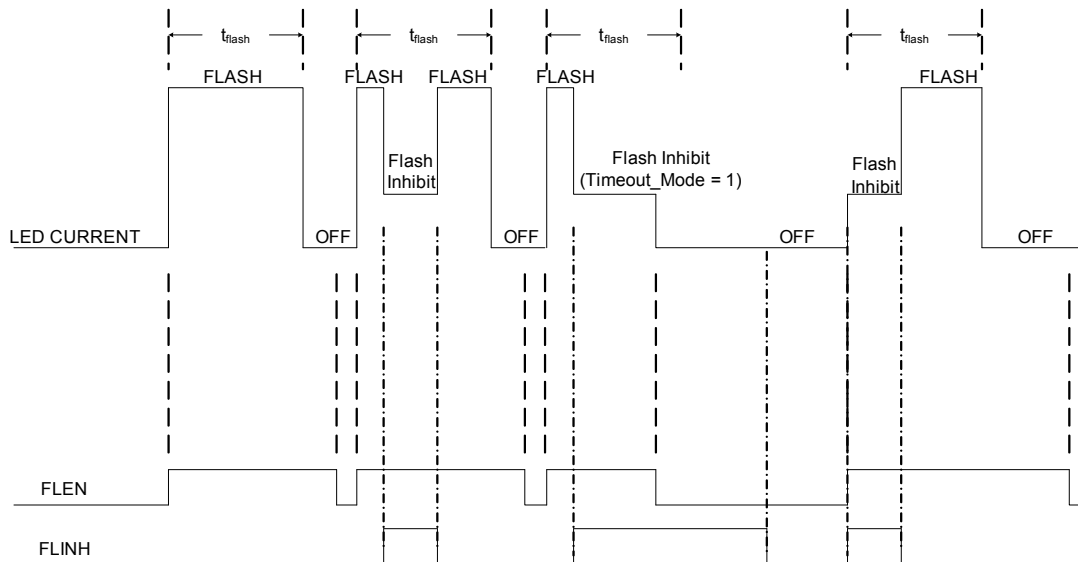

Figure 4-7. LED Flash Timing Diagram

4.9.1 LED Driver Protection

The LED controller shuts down if the CS35L32's temperature exceeds the overtemperature shutdown threshold specified in [Table 3-3](#). The OTE status bit is set and, and if M_OTE = 0, $\overline{\text{INT}}$ is asserted. Recovery starts after the user clears [OTE_RLS](#) (see p. 40), after which, the LED drivers must be retriggered with a FLEN signal for a flash event to occur, or with the LEDx_MVEN enable bit (see [Section 7.24](#)) for a Movie Mode event to occur.

An automatic LED driver shutdown occurs in the event of a shorted or open LED. LED open and short conditions are detected only when a Flash or Movie Mode event is initiated. For a Flash Mode event to occur after clearing the error status bit, the LED drivers must be retriggered with a FLEN signal. For a Movie Mode event to occur after clearing the error status bit, the LEDx_MVEN bit must be set.

4.9.2 LED Driver Interrupt

An interrupt is generated when any of the following conditions or faults occur: LEDx short or open is present when a Flash event is initiated, current limit, boost output overvoltage, or UVLO of VP. The condition is registered in interrupt status register 3, [Section 7.21](#). Its mask is in [Section 7.18](#). If the error conditions are no longer present, $\overline{\text{INT}}$ is reset and deasserted after the interrupt register is read.

Note: The device does not generate an LED open circuit interrupt if the boost converter is running in bypass mode (PDN_BST= 01).

4.9.3 LED Lighting Status Register

The LED lighting status register (see [Section 7.22](#)) reports the state of LEDs and their controls. Status is reported for LED1 and LED2 flash events, indicating whether each LED is driven with current set by the flash setting. Likewise, status is reported for LED1 and LED2 Movie Mode events, indicating whether each LED is driven with current set by the Movie Mode setting. LED2 disable status is reported if FLOUT2 is used without an LED and is tied to ground, as shown in [Fig. 2-1](#). The logic status of the signal input at FLEN and FLINH is reported. Flash timer events are reported.

4.10 Power Budgeting

Power budgeting is configured through [ILED_MNG](#), [AUDIOGAIN_MNG](#), and [VBOOST_MNG](#) (see [p. 38](#)), which set the boost converter's output mode and the load management mode, as described in [Section 4.10.1](#)–[Section 4.10.3](#). Load management consists of reducing audio or LED load, or both, as long as one of the following conditions exists:

- The boost converter output voltage has dropped, provided that the boost converter is configured for a fixed 5-V Mode through [VBOOST_MNG](#) and the load current has settled to its target value.
- The boost converter is in current limit.
- An overtemperature warning (135°C) has occurred.

Power budgeting is configurable to be active automatically without user intervention, semiautomatically, or nonautomatically, where the user controls audio and LED load management.

[Fig. 4-8](#) shows power budgeting.

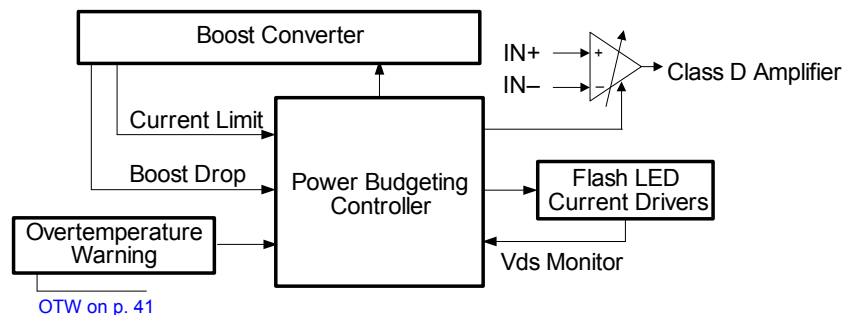

Figure 4-8. Power Budgeting Block Diagram

4.10.1 Audio-Only Operation

If only audio is operating, there are no power-budgeting concerns. As a default, the boost converter's output voltage is fixed in Bypass Mode ($VBST = VP$). The user can set [VBOOST_MNG](#) (see [p. 38](#)) to any of the nondefault modes for a different boost behavior. Refer to [Section 4.3.1](#).

4.10.2 LED-Only Operation

If only LEDs are operating, the user can select one of the following courses of action:

- By clearing [ILED_MNG](#) (see [p. 38](#)), LED current is managed automatically. If the CS35L32 enters load management mode due to a condition listed in [Section 4.10](#), the current is iteratively reduced until the condition no longer exists.
- By setting [ILED_MNG](#), the user maintains full control over LED current.

As a default, the boost converter's output voltage is fixed in Bypass Mode ($VBST = VP$). The user can set [VBOOST_MNG](#) to any of the nondefault modes for a different boost behavior. In particular, if [VBOOST_MNG](#) = 00 or 01 and load power consists of LEDs only, the CS35L32 adapts for low power dissipation by automatically reducing the LED driver voltage (V_{ds}) at pins FLOUT1 and FLOUT2 and by reducing the boost converter's output voltage. Such operation increases boost converter efficiency, lowers temperature rise in the CS35L32, and increases battery run time. If [VBOOST_MNG](#) is set to 10 or 11, the CS35L32 does not adapt for low-power dissipation because the boost voltage is fixed.

4.10.3 Audio and LED Operation

When audio and LEDs are operating simultaneously, the user can select one of the following courses of action:

- By clearing AUDIOGAIN_MNG, if the CS35L32 enters load management mode due to the conditions listed in [Section 4.10](#), audio gain is reduced once by 3 dB (no reduction for 9-dB gain). If the condition persists, the CS35L32 examines ILED_MNG and responds according to [Section 4.10.2](#). Audio automatically recovers to the original volume after an LED event.
- By setting AUDIOGAIN_MNG, the user maintains full control over audio gain.

As a default, the boost converter's output voltage is fixed in Bypass Mode (VBST = VP). The user can set VBOOST_MNG to any of the nondefault modes for a different boost behavior. In particular, if VBOOST_MNG = 01 in the presence of LED and audio load power, the CS35L32 adapts for low-power dissipation by automatically reducing the LED driver voltage at pins FLOUT1 and FLOUT2 and by reducing the boost converter's output voltage. If VBOOST_MNG = 00 in the presence of LED and audio-load power, the boost converter's output voltage is determined by the higher of the two supply requirements for LED or audio Class G. In such a case, the CS35L32 cannot adapt for low power dissipation if audio Class G requires a 5-V supply, because of the higher audio signal. Refer to [Section 4.3.2](#).

4.11 Audio/Data Serial Port (ADSP)

The ADSP transmits audio and data to and from the systems processor in traditional I²S Mode. Controls are provided to advise the device of the rate of the clocks being applied to its inputs when in Slave Mode. Likewise, the same controls are used to indicate the clock rates to be generated when operating as a clock master.

The serial port I/O interface consists of three signals, described in detail in [Table 1-1](#):

- SCLK: Serial data shift clock
- LRCK: Provides the left/right clock, which identifies the start of each serialized data word and toggles at sample rate
- SDOUT: Serial data output

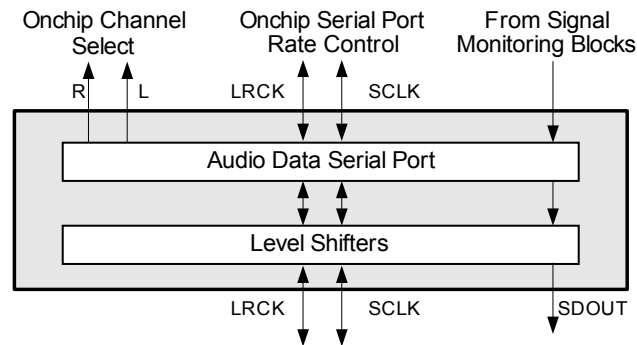

Figure 4-9. Audio/Data Serial Port (ADSP)

[Table 4-5](#) provides links to register fields used to configure components shown in [Fig. 4-9](#).

Table 4-5. ADSP Configuration

Register Field	Cross-Reference to Description
PDN_AMP	Section 7.5
SDOUT_3ST	Section 7.6
MCLKDIS, MCLKDIV2, RATIO	Section 7.7
M/S	Section 7.13
M_ADSPCLK_ERR	Section 7.16
ADSPCLK_ERR	Section 7.19

4.11.1 Power Up, Power Down, and Tristate

The serial port has separate power-down and tristate controls for its output data path (SDOUT_3ST, see [p. 37](#)). ADSP master/slave operation is governed only by the M/S setting (see [p. 39](#)), irrespective of the SDOUT_3ST setting. [Table 4-6](#) describes ADSP operational mode and pin-output driver-state configuration.

Table 4-6. ADSP Operational Mode and Pin Configurations

M/S	SDOUT_3ST	ADSP Operational Mode	SDOUT Pin Driver	LRCK Pin Driver	SCLK Pin Driver
0	0	I ² S Slave Mode	Output	Input	Input
0	1	I ² S Slave Mode	Hi-Z	Input	Input
1	0	I ² S Master Mode	Output	Output	Output
1	1	I ² S Master Mode	Hi-Z	Output	Output

4.11.1.1 Tristating the ADSP SDOUT Path (SDOUT_3ST)

If the SDOUT functionality of the ADSP is not required, power losses caused by the charging and discharging of parasitic capacitances on this pin can be eliminated by setting SDOUT_3ST, so that the SDOUT line is tristated. When reactivating SDOUT, the associated circuits come alive and a full LRCK cycle elapses before SDOUT data is valid.

4.11.2 Master and Slave Timing

The serial port operates as either the master of timing or the slave to another device's timing. When the serial port is master, SCLK and LRCK are outputs; when it is a slave, they are inputs. Master/Slave Mode is configured by the M/S bit.

In I²S Master Mode, the SCLK and LRCK clock outputs are derived from MCLK_{INT}. SCLK is generated to have approximately 64 cycles per LRCK cycle.

In Slave Mode, because there is no sample-rate conversion from the serial port to the device core, the serial port audio sample rate (f_{LRCK}) must equal the core sample rate (F_s). To ensure that the CS35L32 maintains synchronization with the serial port sample rate, the **RATIO** divider (see p. 37) is programmed to indicate the sample rate to MCLK_{INT} relationship.

Table 4-7 shows the corresponding RATIO ($f_{MCLK(INT)}/f_{LRCK}$) for each MCLK_{INT} at the supported LRCK rate. In Master Mode, in a dual-CS35L32 configuration (see Section 4.12.3) with MCLK_{INT} = 6 MHz, a ratio of 125 is not supported.

ADSPCLK_ERR (see p. 41) indicates when the ADSP attempts to resynchronize due to the absence of an LRCK edge at the expected time due to excessive jitter, misprogramming, or clock absence. Note that, given that the clock-checking circuit checks for LRCK edges appearing in the expected location relative to internal timing, if the LRCK frequency is an integer multiple of the expected rate (e.g., the LRCK rate is 96 kHz [2 x 48 kHz] vs. the expected 48 kHz), ADSPCLK_ERR does not detect this error condition. Also note that, since the clock-checking circuit monitors edges, if LRCK is removed and no further clock edges are produced, ADSPCLK_ERR triggers only once while the LRCK is removed.

Table 4-7 lists supported serial-port audio sample rates, their relationship to the MCLK_{INT} rate, and the programming required to generate a given LRCK rate in Master Mode and ensure the serial port maintains synchronization in Slave Mode.

Table 4-7. ADSP Rates

MCLK _{INT} Rate (MHz)	LRCK Rate (kHz)	$f_{MCLK(INT)}/f_{LRCK}$ (Rate Ratio)	RATIO
6.0000	48.000	125	1
6.1440	48.000	128	0

If all amplifier functionality is not being used, but CS35L32 clock mastering is desired, set up the clocks using the clocking control register controls, then set SDOUT_3ST. In this scenario, since the amplifier is inaccessible, it should be powered down to save power (PDN_AMP = 1).

4.11.3 ADSP in I²S Mode

The ADSP operates in traditional I²S format, with a minor modification. On the transmit side, the data structure is modified to transmit nonconventional data (e.g., the monitored signals) in a compatible format. Receive Mode is not supported.

4.11.3.1 Data Bit Depths

The data word length of the I²S interface format is ambiguous. Fortunately, the I²S format is also left justified, with a MSB-to-LSB bit ordering, which negates the need for a word-length control register. The following text describes how different bit depths are handled with the I²S format.

The CS35L32 transmits data that is from 24 to 32 bits deep per channel sample. If fewer than 24 serial clocks are present per channel frame (half LR clock period), it outputs as many bits as there are clocks. If there are more than 24 serial clocks per channel frame, it outputs the bits shown in the extended section for the additional clock cycles after the 24th bit. Any bit beyond the 24th, if marked as reserved, is zero. The receiving device is expected to load the data in MSB-to-LSB order until its word depth is reached, at which point it should discard any remaining LSBs from the interface.

4.12 Signaling Format

The CS35L32 supports the I²S format on its serial port:

- Up to 32 bits/channel of composite data can be sent, as shown in [Table 4-9–Table 4-13](#). Additional bits are packed in the extended section, beyond the 24th bit, and are accessed if a 32-clock frame is used.
- LRCK identifies the transmission start of each channel.
- Data is clocked out of the SDOUT output using the falling edge of SCLK.
- Bit order is MSB to LSB.

Signaling for I²S format is shown in [Fig. 4-10](#).

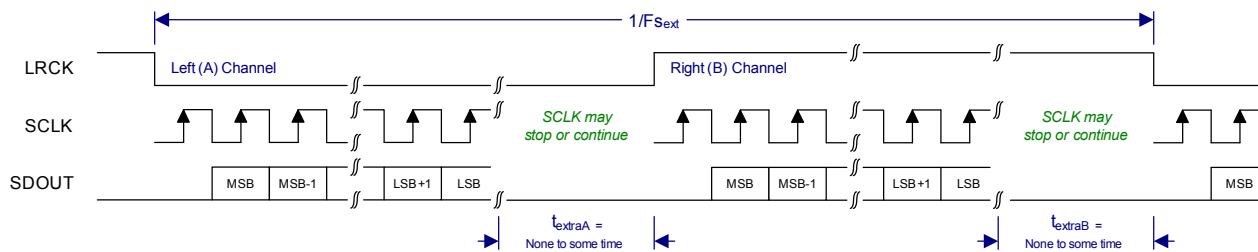

Figure 4-10. I²S Format

4.12.1 Transmitting Data

The CS35L32 includes real-time monitoring of several signals internal and external to the device via integrated ADCs, as well as a number of status bits. The monitoring data exists as three signals—VPMON, VMON, and IMON—which are described in [Section 4.8](#) and [Table 4-8](#), which also describes status bits.

Table 4-8. SDOUT Monitor Data Description

Function	Data Descriptor	Description
Speaker Amplifier Section 4.3.	AMP_SHORT (amplifier short)	Indicates that either of the outputs (OUT+ and/or OUT-) of the amplifier is driving a short circuit 0 (Default) Not shorted 1 Shorted. When this condition exists, the device enters Speaker-Safe Mode. See Section 7.19 and Section 4.3.4 .
Undervoltage Lockout (UVLO) Section 4.5.	UVLO (UVLO event)	0 (Default) No undervoltage lockout 1 UVLO detected at VP. IC shut down. See Section 7.21 .
Boost Converter Section 4.6.	BOOST_CURLIM (boost converter in current limit)	0 (Default) Boost converter is not in current limit 1 Boost converter is in current limit See Section 7.21 .
	BOOST_OVERROR (boost converter overvoltage error)	0 (Default) No overvoltage detected 1 Overvoltage detected See Section 7.21 .
Die Temperature Monitoring, Section 4.7.	OTW (overtemperature warning)	Indicates that device junction temperature exceeded the set limit in Table 3-3 0 (Default) Junction temperature is below the set overtemperature warning threshold 1 Junction temperature is above set overtemperature warning threshold
	OTE (overtemperature error)	Indicates whether the device junction temperature exceeded the damage limit 0 (Default) Junction temperature is below damage limit 1 Junction Temperature is above damage limit. When this condition exists, the device enters Speaker-Safe Mode. See Section 7.19 and Section 4.3.4 .

Table 4-8. SDOOUT Monitor Data Description (Cont.)

Function	Data Descriptor	Description
Signal Monitoring, Section 4.8.	VMON_OVFL (VMON overflow)	xMON overflow. Indicates the overrange status in the VMON, IMON, or VPMON ADC signal path 0 (Default) No clipping has occurred anywhere in the ADC signal path. 1 Clipping has occurred in the ADC signal path. The programming of IMON_SCALE may cause IMON_OVFL to be set. See Section 7.20.
	IMON_OVFL (IMON overflow)	
	VPMON_OVFL (VPMON overflow)	
	VMON (voltage monitor)	16- or 12-bit representation of the voltage across the load, sensed on VSENSE±
	IMON (current monitor)	16- or 12-bit representation of the voltage sensed across an external 0.1-Ω resistor in series with the SPKOUT+ terminal, sensed on ISENSE±
	VPMON (battery voltage)	8-bit representation of the voltage present on VP pin, i.e., the system's battery voltage, sensed internally
LED Driver Section 4.9.	LED12_FLEV (LED12 flash event)	LED1 or LED2 flash event (Logical OR of LED1_FLEV and LED2_FLEV, see p. 43) 0 (Default) No driver flash current delivered to either LED1 or LED 2 1 Flash current delivered to LED1, LED2, or both
	LED12_MVEV (LED12 Movie Mode event)	LED1 or LED2 movie event (Logical OR of LED1_MVEN and LED2_MVEV, see p. 43) 0 (Default) No driver movie current delivered to either LED1 or LED 2 1 Movie current delivered to LED1, LED2, or both
	LED_TIMERON (flash timer)	Flag indicating whether the flash timer is On. See Section 7.22. 0 (Default) LED Flash timer Off 1 LED Flash timer On
Power down	PDN_DONE (power-down done)	Indicates whether the CS35L32 is completely powered down and MCLK can be stopped. See Section 7.20. 0 Not completely powered down. PDN_DONE = 0 if any blocks still require MCLK _{INT} . After powering down using PDN_ALL or the individual power-down bits, the CS35L32 transitions to a powered-down state, after which, PDN_DONE is set and MCLK _{INT} can be removed. 1 (Default) Powered down

4.12.2 Transmitting Data from a Single-CS35L32 Configuration

For a single CS35L32, the user clears **SHARE** (see p. 39). When transmitting data via the ADSP, the monitor data is packed as shown in Table 4-9: left channel VMON[15:0], VPMON[7:0] and right channel IMON[15:0], STATUS.

Table 4-9. SDOOUT Monitor Data Positioning (Single CS35L32)

Bit	Bit Number	Left-Channel Data Contents	Right-Channel Data Contents
MSB	1	VMON[15]	IMON[15]
MSB – 1	2	VMON[14]	IMON[14]
...
MSB – 15	16	VMON[0]	IMON[0]
MSB – 16	17	VPMON[7]	AMP_SHORT
MSB – 17	18	VPMON[6]	OTW
MSB – 18	19	VPMON[5]	OTE
MSB – 19	20	VPMON[4]	VMONIMON_OVFL
MSB – 20	21	VPMON[3]	VPMON_OVFL
MSB – 21	22	VPMON[2]	PDN_DONE
MSB – 22	23	VPMON[1]	BOOST_CURLIM
MSB – 23	24	VPMON[0]	LED_TIMERON
MSB – 24	25	Reserved	VMON_OVFL
MSB – 25	26	Reserved	IMON_OVFL
MSB – 26	27	Reserved	UVLO
MSB – 27	28	Reserved	BOOST_OVERROR
MSB – 28	29	Reserved	LED12_FLEV
MSB – 29	30	Reserved	LED12_MVEV
MSB – 30	31	Reserved	Reserved
MSB – 31	32	Reserved	Reserved

4.12.3 Transmitting Data from a Dual-CS35L32 Configuration

To indicate a dual-CS35L32 configuration where the SDOU line is shared, the user must set **SHARE** (see p. 39). When two CS35L32 devices are available on the same board, each device is identified by its I²C address. The AD0 pin is shared by FLOUT2. Upon power-up or upon deasserting **RESET**, each CS35L32 reads the AD0 pin logic level and configures its chip address. Transmission starts when **SDOUT_3ST** (see p. 37) is cleared. The Device 0 address (AD0 level low) transmits its data on the left channel time slot while Device 1 is automatically tristated; the Device 1 address (AD0 level high) transmits on the right-channel time slot while Device 0 is automatically tristated.

The **DATCNF** setting (see p. 39) determines data transmission for both CS35L32s, as shown below:

- [Table 4-10](#) (DATCNF = 00): left and right channel VMON[11:0], IMON[11:0], VPMON[7:0]
- [Table 4-11](#) (DATCNF = 01): left and right channel VMON[11:0], IMON[11:0], STATUS
- [Table 4-12](#) (DATCNF = 10): left and right channel VMON[15:0], IMON[15:0]
- [Table 4-13](#) (DATCNF): left and right channel VPMON[7:0], STATUS

Table 4-10. SDOU Monitor Data Positioning (Two CS35L32s, DATCNF = 00)

Bit	Bit Number	Left-Channel Data Contents	Right-Channel Data Contents
MSB	1	VMON[11] Device 0	VMON[11] Device 1
MSB – 1	2	VMON[10] Device 0	VMON[10] Device 1
...
MSB – 11	12	VMON[0] Device 0	VMON[0] Device 1
MSB – 12	13	IMON[11] Device 0	IMON[11] Device 1
MSB – 13	14	IMON[10] Device 0	IMON[10] Device 1
...
MSB – 23	24	IMON[0] Device 0	IMON[0] Device 1
MSB – 24	25	VPMON[7] Device 0	VPMON[7] Device 1
MSB – 25	26	VPMON[6] Device 0	VPMON[6] Device 1
...
MSB – 31	32	VPMON[0] Device 0	VPMON[0] Device 1

Table 4-11. SDOU Monitor Data Positioning (Two CS35L32s, DATCNF = 01)

Bit	Bit Number	Left-Channel Data Contents	Right-Channel Data Contents
MSB	1	VMON[11] Device 0	VMON[11] Device 1
MSB – 1	2	VMON[10] Device 0	VMON[10] Device 1
...
MSB – 11	12	VMON[0] Device 0	VMON[0] Device 1
MSB – 12	13	IMON[11] Device 0	IMON[11] Device 1
MSB – 13	14	IMON[10] Device 0	IMON[10] Device 1
...
MSB – 23	24	IMON[0] Device 0	IMON[0] Device 1
MSB – 24	25	AMP_SHORT Device 0	AMP_SHORT Device 1
MSB – 25	26	OTW Device 0	OTW Device 1
MSB – 26	27	OTE Device 0	OTE Device 1
MSB – 27	28	VMONIMON_OVFL Device 0	VMONIMON_OVFL Device 1
MSB – 28	29	VPMON_OVFL Device 0	VPMON_OVFL Device 1
MSB – 29	30	PDN_DONE Device 0	PDN_DONE Device 1
MSB – 30	31	BOOST_CURLIM Device 0	BOOST_CURLIM Device 1
MSB – 31	32	LED_TIMERON Device 0	LED_TIMERON Device 1

Table 4-12. SDOU Monitor Data Positioning (Two CS35L32s, DATCNF = 10)

Bit	Bit Number	Left Channel Data Contents	Right Channel Data Contents
MSB	1	VMON[15] Device 0	VMON[15] Device 1
MSB – 1	2	VMON[14] Device 0	VMON[14] Device 1
...
MSB – 15	16	VMON[0] Device 0	VMON[0] Device 1
MSB – 16	17	IMON[15] Device 0	IMON[15] Device 1
MSB – 17	18	IMON[14] Device 0	IMON[14] Device 1
...
MSB – 31	32	IMON[0] Device 0	IMON[0] Device 1

Table 4-13. SDOIT Monitor Data Positioning (Two CS35L32s, DATCNF = 11)

Bit	Bit Number	Left Channel Data Contents	Right Channel Data Contents
MSB	1	VPMON[7] Device 0	VPMON[7] Device 1
MSB – 1	2	VPMON[6] Device 0	VPMON[6] Device 1
...
MSB – 7	8	VPMON[0] Device 0	VPMON[0] Device 1
MSB – 8	9	AMP_SHORT Device 0	AMP_SHORT Device 1
MSB – 9	10	OTW Device 0	OTW Device 1
MSB – 10	11	OTE Device 0	OTE Device 1
MSB – 11	12	VMONIMON_OVFL Device 0	VMONIMON_OVFL Device 1
MSB – 12	13	VPMON_OVFL Device 0	VPMON_OVFL Device 1
MSB – 13	14	PDN_DONE Device 0	PDN_DONE Device 1
MSB – 14	15	BOOST_CURLIM Device 0	BOOST_CURLIM Device 1
MSB – 15	16	LED_TIMERON Device 0	LED_TIMERON Device 1
MSB – 16	17	VMON_OVFL Device 0	VMON_OVFL Device 1
MSB – 17	18	IMON_OVFL Device 0	IMON_OVFL Device 1
MSB – 18	19	UVLO Device 0	UVLO Device 1
MSB – 19	20	BOOST_OVERROR Device 0	BOOST_OVERROR Device 1
MSB – 20	21	LED12_FLEV Device 0	LED12_FLEV Device 1
MSB – 21	22	LED12_MVEV Device 0	LED12_MVEV Device 1
MSB – 22 to MSB – 31	23–32	Reserved	Reserved

4.13 Device Clocking

The device can operate as a clock master, creating both SCLK and LRCK for itself and for other devices in the system. It can also be operated as a clock slave, receiving the SCLK and LRCK signals as input. In either case, internal controls are used to advise (in Slave Mode) or set (in Master Mode) the clocking relationships among the externally applied MCLK, the internally derived MCLK (MCLK_{INT}), SCLK, and LRCK.

4.13.1 Internal Master Clock Generation

An internal clock (MCLK_{INT}) is derived from the clocking signal that drives the MCLK pin. The user must configure [MCLKDIV2](#) (see [p. 37](#)) so the proper internal MCLK signal can be derived. When the external clock is 6 or 6.144 MHz, MCLK_{INT} can simply be a buffered version of the clock that drives the MCLK pin. This is done by clearing MCLKDIV2. However, if the external clock is 12 or 12.288 MHz, it must be halved to achieve an MCLK_{INT} rate of approximately 6 MHz. This is done by setting MCLKDIV2.

[Table 4-14](#) outlines the supported internal MCLK_{INT} nominal frequency and how it is derived from the supported frequencies of the external MCLK source (MCLK input pin).

To save power, MCLK can be disabled by setting [MCLKDIS](#) (see [p. 37](#)).

Table 4-14. Internal Master Clock Generation

MCLK Rate (MHz)	Required Divide Ratio	MCLK _{INT} Rate (MHz)	Settings for MCLKDIV2
6.0000	1	6.0000	0
12.0000	2		1
6.1440	1	6.1440	0
12.2880	2		1

4.13.2 ADSP Device Clocking

The CS35L32 can operate as a clock master, creating both SCLK and LRCK for itself and for other system devices. It can also operate as a clock slave, receiving SCLK and LRCK signals as inputs. In Master Mode, CS35L32 determines clocking relationships among SCLK, LRCK, and the externally applied MCLK.

4.13.3 Error Conditions

MCLK, SCLK, and LRCK are monitored for clocking and configuration errors. If an MCLK or ADSP error occurs, the respective MCLK_ERR or ADSPCLK_ERR bit is set, and, if the respective mask bit is cleared, $\overline{\text{INT}}$ is asserted.

- **MCLK error (MCLK_ERR).** If MCLK were to stop abruptly while the boost converter or amplifier's output stages are switching, it could damage or destroy the device. Because of this, the CS35L32 integrates a watchdog circuit to monitor MCLK frequency. To prevent damage, if MCLK is removed or drops below ~1.25 MHz, the boost converter is placed in Bypass Mode and audio and LED operations are shut down. The Class D amplifier immediately stops switching and both outputs are internally clamped to ground. After such a disturbance, once a proper MCLK can be applied, the device should be reset to ensure recovery to a known state.

Whenever the MCLK watchdog determines that MCLK is too slow, the event is recorded in [MCLK_ERR](#) (see [p. 41](#)). If MCLK_ERR is set, the device must be reset ($\overline{\text{RESET}} = \text{HIGH} \rightarrow \text{LOW}$), released from reset ($\overline{\text{RESET}} = \text{LOW} \rightarrow \text{HIGH}$) once a valid MCLK is reapplied, and then restarted adhering to the specifications in [Table 3-11](#). Once restarted, default audio functionality resumes with the boost converter in Bypass Mode. Registers must be reloaded, since the $\overline{\text{RESET}}$ operation will have cleared them.

- **ADSPCLK error (ADSPCLK_ERR).** If the ADSP_RATIO is not configured properly for the MCLK and audio clocks supplied to the CS35L32, an ADSP error is triggered ([ADSPCLK_ERR = 1](#), see [p. 41](#)). [Section 4.11.2](#) describes ADSPCLK_ERR and how to configure the ADSP.

The CS35L32 monitors the MCLK_{INT}-to-LRCK ratio to determine whether it is valid according to the [RATIO](#) setting (see [p. 37](#)). If it is invalid, an ADSPCLK_ERR error occurs and, if M_ADSPCLK_ERR = 0, $\overline{\text{INT}}$ is asserted.

While the ADSP is attempting to correlate the incoming clocks to the settings of the ratio controls, the state machine may flag the error condition several times, causing multiple assertions of the $\overline{\text{INT}}$ pin. To avoid this, the mask bit for this error can be set after the initial notice, followed by the actions from a service routine to clear the error, and then clearing the mask bit once the service routine has run.

This error is cleared automatically when the ratio matches the control port settings.

4.14 Control Port Operation

The control port is used to access the registers allowing the amplifier and LED drivers to be configured for the desired operational modes and formats. Control port operation can be asynchronous with respect to the audio sample rates. However, to avoid potential interference problems, the control-port pins should remain static if no operation is required.

The control port operates using an I²C interface with the amplifier acting as a slave device. Device communication should not begin until the reset and power-up timing requirements specified in [Table 3-11](#) and [Table 3-13](#) are met.

Note: The VA and VP supplies are needed for proper control-port operation. Additionally, although registers can be written to and read from while MCLK is powered down, a valid MCLK is required to advance the state machines affected by register settings.

4.14.1 I²C Interface and Protocol

The serial control-port data pin, SDA, is a bidirectional data line. Data is clocked into and out of the CS35L32 by the I²C clock, SCL. The signal timings for read and write cycles are shown in [Fig. 4-11](#)–[Fig. 4-13](#). A start condition is defined as a falling transition of SDA while the clock is high. A stop condition is defined as a rising transition of SDA while the clock is high. All other SDA transitions occur while the clock is low.

The first byte sent to the CS35L32 after a start condition consists of a 7-bit chip address field and a $\overline{\text{R/W}}$ bit (high for a read, low for a write) in the LSB. To communicate with the CS35L32, the I²C slave address, shown in [Fig. 4-11](#), should match 100 0000 if the AD0 pin is at level 0, and should match 100 0001 if it is at level 1.

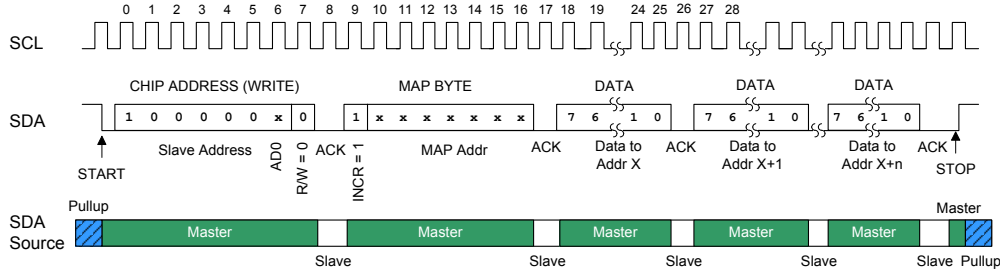

Figure 4-11. Control-Port Timing—I²C Writes with Autoincrement

The logic state of FLOUT2/AD0 configures the I²C device address upon a device power up, after $\overline{\text{RESET}}$ has been deasserted. The bit labeled AD0 in the address byte in Fig. 4-11 reflects the logic state of pin FLOUT2/AD0.

If the I²C operation is a write, the next byte is the memory address pointer (MAP); the 7 LSBs of the MAP byte select the address of the register to be read or written to next. The MSB of the MAP byte, INCR, selects whether autoincrementing is to be used (INCR = 1), allowing successive reads or writes of consecutive registers.

Each byte is separated by an acknowledge bit, ACK, which the CS35L32 outputs after each input byte is read and is input to the CS35L32 from the microcontroller after each transmitted byte.

Also for writes, bytes following the MAP byte are written to the CS35L32 register addresses pointed to by the last received MAP address plus however many autoincrements have occurred. Fig. 4-11 shows a write pattern with autoincrementing.

If the operation is a read, the contents of the register pointed to by the last received MAP address plus however many autoincrements have occurred, are output in the next byte. Fig. 4-12 shows a read pattern following the write pattern in Fig. 4-11. Notice how read addresses are based on the MAP byte from Fig. 4-11.

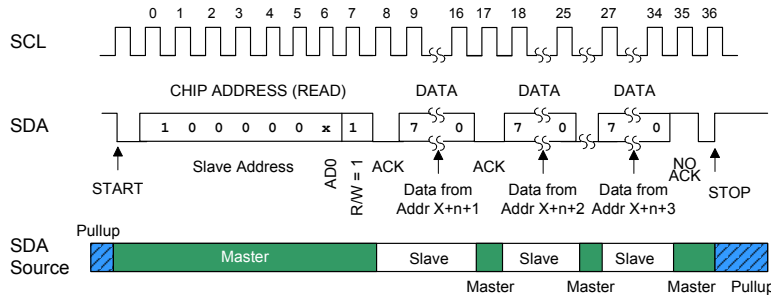

Figure 4-12. Control-Port Timing—I²C Reads with Autoincrement

If a read address different from that based on the last received MAP address is desired, an aborted write operation can be used as a preamble that sets the desired read address. This preamble technique is shown in Fig. 4-13, in which a write operation is aborted (after the ACK for the MAP byte) by sending a stop condition.

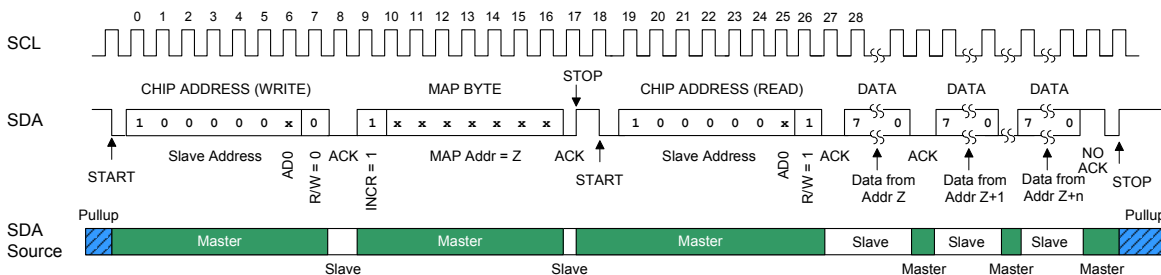

Figure 4-13. Control-Port Timing—I²C Reads with Preamble and Autoincrement

The following pseudocode illustrates an aborted write operation followed by a single read operation when the AD0 bit in the slave address is 0. For multiple read operations, autoincrement would be set to ON (as shown in Fig. 4-13).

```
Send start condition.
Send 10000000 (chip address and write operation).
Receive acknowledge bit.
Send MAP byte, autoincrement off.
```

```
Receive acknowledge bit.  
Send stop condition, aborting write.  
Send start condition.  
Send 10000001 (chip address and read operation).  
Receive acknowledge bit.  
Receive byte, contents of selected register.  
Send acknowledge bit.  
Send stop condition.
```

Note: For I²C reads, the interrupt status registers and the register at the address that precedes an interrupt status register must be read individually and not as a part of an autoincremented control-port read. An autoincremented read of any of these registers may clear the contents of an interrupt status register and return invalid interrupt status data. As a result, if an unmasked interrupt condition had caused the $\overline{\text{INT}}$ pin to be asserted, the autoincremented read that prematurely clears the corresponding interrupt status bit causes $\overline{\text{INT}}$ to be deasserted. Therefore, to avoid affecting interrupt status register contents, interrupt status registers and the register at the preceding address (specifically, registers at addresses 0x14–0x17) must only be read individually.

5 Applications

5.1 Required Reserved Register Configuration

The following initialization sequence must be written after the release of reset but before power down bit is cleared:

- Write register 0x00 with the value 0x99.
- Write register 0x43 with the value 0x01.
- Write register 0x00 with the value 0x00.

To address the issue where a small dip can be seen in the audio output signal as the amplifier enters clipping, the following I²C sequence must be written at initialization:

- Write register 0x00 with the value 0x99.
- Write register 0x3B with the value 0x62.
- Write register 0x3C with the value 0x80.
- Write register 0x00 with the value 0x00.

To address the issue where spurious tones exist on both the IMON/VMON ADCs during idle channel conditions, the following I²C sequence must be written at initialization to reduce the amplitude of these tones:

- Write register 0x00 with the value 0x99.
- Write register 0x24 with the value 0x40.
- Write register 0x00 with the value 0x00.

By default, the boost converter output is incorrect if VP exceeds 3.7 V. When a boost event is requested in this condition, the boost converter output is 5.8 V instead of the nominal 5 V.

The following I²C sequence must be written at initialization to correct this behavior:

- Write register 0x00 with the value 0x99.
- Write register 0x49 with the value 0x56.
- Write register 0x00 with the value 0x00.

5.2 Avoiding Current Transients when Issuing a Flash Event

When the boost converter is configured in either of the two automatic managed modes (VBOOST_MNG = 00 or VBOOST_MNG = 01) and a flash LED event is indicated, a current transient can be seen at the output of the boost converter (VBST) through FLOUTx whenever a voltage boost is requested. The duration of this transient is approximately 200 μs . A current transient is also observed in the current that sources VP. The LED current settles to the programmed value in the LED_FLCUR field after the current transient.

To avoid the current transient on the VP node, the boost converter management must be configured for a fixed 5-V boost operation ($VBOOST_MNG = 11$) before issuing a flash event. $VBOOST_MNG$ may be reconfigured to the desired management mode after a flash event.

The following sequence should be followed when issuing a flash event:

- Configure $VBOOST_MNG$ to fixed 5-V Mode ($VBOOST_MNG = 11$).
- Trigger a flash event by asserting $FLEN$.
- Wait for the expiration of the flash timer period.

5.3 External Component and PCB Design Considerations—EMI Output Filtering

In a portable application, it is important not only to pass far-field radiated emissions compliance testing such as FCC Part 15 or EN55022, but to minimize near-field emissions. In general, far-field compliance testing ensures that an electronic device does not interfere with other electronic devices. Also, near-field emissions are more of a concern when ensuring that an electronic device does not interfere with itself. As the name indicates, near-field emissions typically do not propagate far enough to interfere with another device.

Depending on system characteristics (e.g., PCB layout, stack-up, supply decoupling, the connection length to the load, presence of external shielding, sensitivity of other devices on the system, and proximity to any sensitive devices or antennas), an EMI reduction may be necessary over the performance of what is obtained with the typical connection diagram (see Fig. 2-1). Because most Class D amplifier emissions are produced or transmitted via the output stage, changes are typically limited to adding passive filtering to $SPKOUT+$ and $SPKOUT-$. For sensitive systems, it is recommended to add a ferrite-bead capacitor (FB-C) output filter to help ensure sufficient attenuation of the high-frequency energy. Fig. 5-1 shows recommended $VMON$ and $IMON$ connections where an FB-C output filter is used.

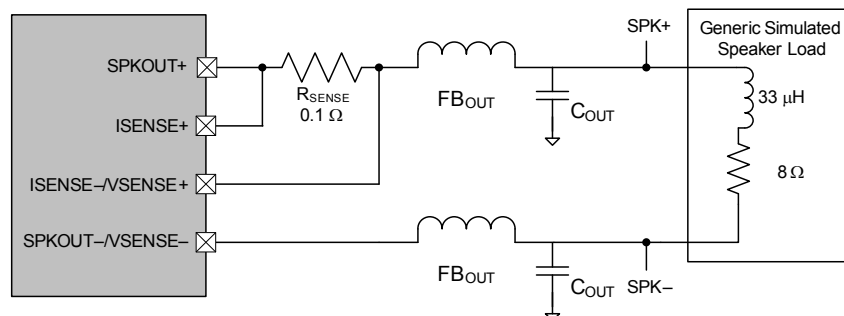

Figure 5-1. $VMON$ and $IMON$ Connections with FB-C EMI Filtering

5.4 PCB Routing Considerations for Thermal Relief

Due to the thermal dissipation properties inherent to a wafer-level chip scale package (WLCSP)—and because the CS35L32 contains a boost converter, Class D amplifier, and LED driver, which can dissipate a fair amount of thermal energy—the PCB design should account for how to remove heat from the device.

The simplest approach is to take advantage of as many GND ball locations as possible and connect them in a manner that allows for good thermal conduction. For example, a 10-mil diameter, 6-mil drill through-hole microvia under each nonblocking GND ball location would allow thermal energy to transmit through the PCB and reach the back-side surface, where it dissipates most effectively. For reference purpose, GND balls are B5, C2, C3, C5, as shown in gray in Fig. 5-2.

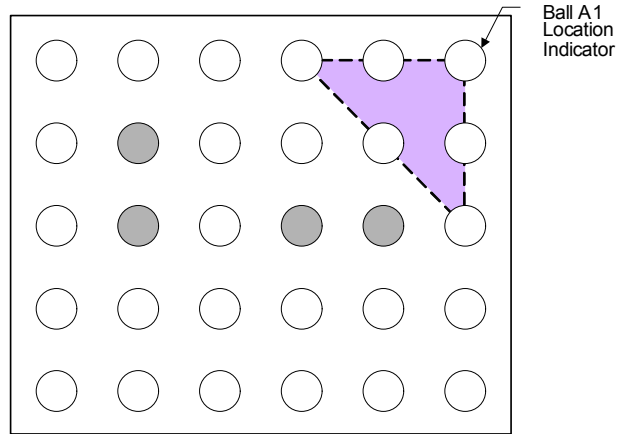

Figure 5-2. Ground Ball Locations (Shown in Gray)

Also, as space permits, traces should be wider than 12 mils as soon as they clear the balls of the device. The traces should remain wide for at least 300 mils after they leave the device.

5.5 Inductor Selection

Table 5-1, "Recommended Inductors," lists the inductors recommended for use with the CS35L32.

Table 5-1. Recommended Inductors

Manufacturer	Part Number	Inductance	DC Resistance	Saturation Current ¹	Height
Cyntec	PST031B-1R0MS	1.0 μ H	8.5 m Ω	3.9 A	1.2 mm
Cooper	MPI4040R1-1R0-R	1.0 μ H	40 m Ω	7.7 A	1.2 mm

1. Indicates the inductor's saturation current corresponding to a 30% drop in inductance from the nominal value.

6 Register Quick Reference

Default values are shown below the bit names.

I ² C Address: AD0 = 0: 1000000[R/W] – 10000000 = 0x80 (Write); 10000001 = 0x81 (Read); AD0 = 1: 1000001[R/W] – 10000010 = 0x82 (Write); 10000011 = 0x83 (Read)									
Adr.	Function	7	6	5	4	3	2	1	0
0x01 p. 36	Device ID A and B (Read Only)	DEVIDA[3:0]			DEVIDB[3:0]				
		0	0	1	1	0	1	0	1
0x02 p. 36	Device ID C and D (Read Only)	DEVIDC[3:0]			DEVIDD[3:0]				
		1	0	1	0	0	0	1	1
0x03 p. 36	Device ID E (Read Only)	DEVIDE[3:0]			—				
		0	0	1	0	0	0	0	0
0x04	Reserved	—							
		0	0	0	0	0	0	0	0
0x05 p. 36	Revision ID (Read Only)	AREVID[3:0]			NUMREVID[3:0]				
		x	x	x	x	x	x	x	x
0x06 p. 36	Power Control 1	PDN_AMP	—		PDN_BST[1:0]		—		PDN_ALL
		0	0	0	0	0	1	0	0
0x07 p. 37	Power Control 2	PDN_VMON	PDN_IMON	PDN_VPMON	—		SDOUT_3ST	—	
		1	1	1	0	1	0	0	0
0x08 p. 37	Clocking Control	MCLKDIS	MCLKDIV2	—				RATIO	
		0	1	0	0	0	0	0	0
0x09 p. 37	Low Battery Thresholds	—		LOWBAT_TH[1:0]		LOWBAT_RECOV[2:0]			—
		0	0	1	0	0	1	1	0
0x0A p. 38	Battery Voltage Monitor (Read Only)	VPMON[7:0]							
		0	0	0	0	0	0	0	0
0x0B p. 38	Boost Converter Peak Current Protection Control	BST_IPK[7:0]							
		0	1	0	0	0	0	0	0
0x0C p. 38	Scaling	—			IMON_SCALE[3:0]				
		0	0	0	0	0	1	1	1
0x0D p. 38	LED and Audio Power-Budget Management	—		ILED_MNG	AUDIOGAIN_MNG	—		VBOOST_MNG[1:0]	
		0	0	0	0	0	0	1	0
0x0E	Reserved	—							
		x	x	x	x	x	x	x	x
0x0F p. 39	ADSP Control	ADSP_DRIVE	M/S	DATCNF[1:0]		SHARE		—	
		0	0	1	0	0	0	0	0
0x10 p. 39	Class D Amplifier Control	—		AMP_GAIN[2:0]		GAIN_CHG_ZC		—	
		0	0	0	1	0	1	0	0
0x11 p. 39	Protection Release Control	—				AMP_SHORT_RLS		—	
		0	0	0	0	0	0	0	0
0x12 p. 40	Interrupt Mask 1	—		M_ADSPCLK_ERR	M_MCLK_ERR	M_AMP_SHORT	M_OTW	M_OTE	
		1	1	1	1	1	1	1	1
0x13 p. 40	Interrupt Mask 2	M_VMON_OVFL	M_IMON_OVFL	M_VPMON_OVFL	—				M_PDN_DONE
		1	1	1	1	1	1	1	1
0x14 p. 41	Interrupt Mask 3	M_UVLO	M_LED2_OPEN	M_LED2_SHORT	M_LED1_OPEN	M_LED1_SHORT	M_LOWBAT	M_BOOST_CURLIM	M_BOOST_OVERROR
		1	1	1	1	1	1	1	1
0x15 p. 41	Interrupt Status 1 (Audio) (Read Only)	—			ADSPCLK_ERR	MCLK_ERR	AMP_SHORT	OTW	OTE
		x	x	x	x	x	x	x	x
0x16 p. 42	Interrupt Status 2 (Monitors) (Read Only)	VMON_OVFL	IMON_OVFL	VPMON_OVFL	—				PDN_DONE
		x	x	x	x	x	x	x	x
0x17 p. 42	Interrupt Status 3 (LEDs and Boost Converter) (Read Only)	UVLO	LED2_OPEN	LED2_SHORT	LED1_OPEN	LED1_SHORT	LOWBAT	BOOST_CURLIM	BOOST_OVERROR
		x	x	x	x	x	x	x	x
0x18 p. 43	LED Lighting Status (Read Only)	LED1_FLEV	LED2_FLEV	LED1_MVEV	LED2_MVEV	LED_FLEN	LED_FLINH	LED2_DIS	LED_TIMERON
		x	x	x	x	x	x	x	x
0x19 p. 43	LED Flash Mode Current	—				LED_FLCUR[3:0]			
		0	0	0	0	0	0	0	0
0x1A p. 44	LED Movie Mode Current	—		LED_MVCUR[2:0]		—		LED1_MVEN	LED2_MVEN
		0	0	0	0	0	0	0	0
0x1B p. 44	LED Flash Timer	—			TIMER[4:0]				TIMEOUT_MODE
		0	0	1	0	0	1	0	0
0x1C p. 44	LED Flash Inhibit Current	—				LED_FLINHCUR[3:0]			
		0	0	0	0	0	0	0	0
0x1D –0x7F	Reserved	—							
		x	x	x	x	x	x	x	x

7 Register Descriptions

All registers are read/write except for the chip ID and revision register and the status registers, which are read only. The user must not change reserved registers from their default state.

7.1 Device ID A and B

Address 0x01

R/O	7	6	5	4	3	2	1	0
	DEVIDA[3:0]				DEVIDB[3:0]			
Default	0	0	1	1	0	1	0	1

7.2 Device ID C and D

Address 0x02

R/O	7	6	5	4	3	2	1	0
	DEVIDC[3:0]				DEVIDD[3:0]			
Default	1	0	1	0	0	0	1	1

7.3 Device ID E

Address 0x03

R/O	7	6	5	4	3	2	1	0
	DEVIDE[3:0]				—			
Default	0	0	1	0	0	0	0	0

Bits	Name	Description
7:4	DEVIDA, DEVIDC, DEVIDE	Device ID code for the CS35L32. DEVIDA 0x3 DEVIDB 0x5
3:0	DEVIDB, DEVIDD	DEVIDC 0xA Represents the “L” in CS35L32. DEVIDD 0x3 DEVIDE 0x2

7.4 Revision ID

Address 0x05

R/O	7	6	5	4	3	2	1	0
	AREVID[3:0]				NUMREVID[3:0]			
Default	x	x	x	x	x	x	x	x

Bits	Name	Description
7:4	AREVID	Alpha revision. AREVID and NUMREVID form the complete device revision ID (e.g., A0, B2). 0xA A ... 0xF F
3:0	NUMREVID	Numerical revision. AREVID and NUMREVID form the complete device revision ID (e.g., A0, B2). 0x0 0 ... 0xF F

7.5 Power Control 1

Address 0x06

R/W	7	6	5	4	3	2	1	0
	PDN_AMP	—			PDN_BST[1:0]		—	PDN_ALL
Default	0	0	0	0	0	1	0	0

Bits	Name	Description
7	PDN_AMP	Power down Class D amplifier. Configures the power state of the Class D amplifier. 0 (Default) Powered up 1 Powered down
6:4	—	Reserved
3:2		Power-down boost converter. Configures the power state of the boost converter. 00 Powered up 01 (Default) Boost Mode bypass. Turns the boost FET OFF, the rectifying FET ON, and the remaining boost circuitry in a low-power state, with VBST = VP. Powers down internal-control circuitry when operating in VBST = VP Mode. 10–11 Reserved
1	—	Reserved
0	PDN_ALL	Power down all. Configures the CS35L32 power state. Can be used to quickly power down the device but is not equivalent to using all of the individual power-down bits. 0 (Default) Powered up, as per individual controls in power control registers 1 and 2. 1 Powered down. All affected blocks are powered down, regardless of individual power-down bit settings.

7.6 Power Control 2
Address 0x07

R/W	7	6	5	4	3	2	1	0
	PDN_VMON	PDN_IMON	PDN_VPMON	—	SDOUT_3ST		—	
Default	1	1	1	0	1	0	0	0

Bits	Name	Description
7	PDN_VMON	Power-down VMON ADC. Configures the power state of the ADC front end and the ADC used to monitor the VSENSE± input pins to create the VMON data. 0 Powered up 1 (Default) Powered down
6	PDN_IMON	Power-down IMON ADC. Configures the power state of the ADC front end, and the ADC, and range selection circuitry used to monitor the ISENSE± input pins to create the IMON data. 0 Powered up 1 (Default) Powered down
5	PDN_VPMON	Power-down VPMON ADC. Configures the ADC front end power state and the ADC used to monitor the VP supply pin to create the VP data. 0 Powered up 1 (Default) Powered down
4	—	Reserved
3	SDOUT_3ST	Tristate the ADSP SDOUT path. Configures the Hi-Z state of the ADSP SDOUT output path. 0 SDOUT is powered up. 1 (Default) SDOUT is Hi-Z.
2:0	—	Reserved

7.7 Clocking Control
Address 0x08

R/W	7	6	5	4	3	2	1	0
	MCLKDIS	MCLKDIV2			—			RATIO
Default	0	1	0	0	0	0	0	0

Because clock rates must be stable when the device is powered up, the device must be powered down before changing clock rates.

Bits	Name	Description
7	MCLKDIS	MCLK disable. Configures the state of MCLK _{INT} before its fan-out to all the internal circuitry. 0 (Default) On 1 Off. Disables the clock tree to save power when the device is powered down. Set only after the device powers down.
6	MCLKDIV2	MCLK divide by 2. Configures a divide between the input pin MCLK and the derived core clock, MCLK _{INT} . 0 No divide 1 (Default) Divide by 2
5:1	—	Reserved
0	RATIO	$f_{MCLK(INT)}/f_{LRCK}$ ratio. Table 3-12 shows the effect of these settings on the Master Mode duty cycle. 0 (Default) 128 1 125 Application: Refer to Section 4.11.2, "Master and Slave Timing."

7.8 Low Battery Thresholds
Address 0x09

R/W	7	6	5	4	3	2	1	0
	—		LOWBAT_TH[1:0]		LOWBAT_RECOV[2:0]			—
Default	0	0	1	0	0	1	1	0

Bits	Name	Description
7:6	—	Reserved
5:4	LOWBAT_TH	Low battery nominal threshold, falling VP. See Table 3-3 for accuracy specifications. 00 3.1 V 01 3.2 V 10 (Default) 3.3 V 11 3.4 V
3:1	LOWBAT_RECOV	Low battery nominal recovery threshold, rising VP. See Table 3-3 for accuracy specifications. 000 Reserved 010 3.3 V 100 3.5 V 110–111 3.6 V 001 3.2 V 011 (Default) 3.4 V 101 3.6 V
0	—	Reserved.

7.9 Battery Voltage Monitor
Address 0x0A

R/O	7	6	5	4	3	2	1	0
	VPMON[7:0]							
Default	0	0	0	0	0	0	0	0

Bits	Name	Description
7:0	VPMON	Battery voltage (VP) monitor. Represents the VPMON (D _{OUT}) value in the equation in Section 4.8.4 . 1000 0000–128 1111 1111–1 0000 0001 +1 0111 1111 +127 1000 0001–127... 0000 0000 0 (default) 0000 0010 +2 ...

7.10 Boost Converter Peak Current Protection Control
Address 0x0B

R/W	7	6	5	4	3	2	1	0
	BST_IPK[7:0]							
Default	0	1	0	0	0	0	0	0

Bits	Name	Description
7:0	BST_IPK	Boost converter peak current limit (A). Configures the peak current limit on the boost converter's output. If the amplifier or LEDs attempt to draw current above this limit, only the set limit current is provided and, consequently, the boost voltage droops. The user must not write values higher than 0x80 to this register. 0000 0000 2.89 ... 0100 0000 (Default) 3.72 ... 1000 0000 4.56 0010 0000 3.30 ... 0110 0000 4.14 ... 1000 0001–1111 1111 Reserved

7.11 Scaling
Address 0x0C

R/W	7	6	5	4	3	2	1	0
			—			IMON_SCALE[3:0]		
Default	0	0	0	0	0	1	1	1

Bits	Name	Description
7:4	—	Reserved
3:0	IMON_SCALE	Select IMON ADC scaling. Configures the scaling of data bits from the ADC to be output from the ADSP as the IMON data word. The scale is selected from the encoded ADC output data bus with bit 22 being the ADC data MSB. Scaling control can be used to improve the reported sample resolution for low-level signals or to divide down the signal. 0000 15 down to 0 0111 (Default) 22 down to 7 1001 24 down to 9 1011–1111 Reserved ... 1000 23 down to 8 1010 25 down to 10

Note: For 12-bit implementations, IMON_SCALE remains the same. The MSB is in the same place for 12- and 16-bit formats.

7.12 LED and Audio Power-Budget Management
Address 0x0D

R/W	7	6	5	4	3	2	1	0
				ILED_MNG	AUDIOGAIN_MNG		VBOOST_MNG[1:0]	
Default	0	0	0	0	0	0	1	0

Bits	Name	Description
7:5	—	Reserved
4	ILED_MNG	LED current management 0 (Default) Automatically reduce LED current, only to avoid thermal shutdown or current limiting the boost converter. 1 User controls LED current (nonautomatic).
3	AUDIOGAIN_MNG	Audio-gain management when LEDs are active. 0 (Default) Automatically reduces audio volume once by 3 dB, only if needed to avoid thermal shutdown or current limiting the boost converter. If the condition persists, the CS35L32 examines ILED_MNG and responds accordingly. Audio recovers to original volume automatically at the end of the LED event. 1 User controls audio volume (nonautomatic).
2	—	Reserved
1:0	VBOOST_MNG	Boost voltage control. 00 Automatically managed. Boost-converter output voltage is the higher of the two: Class G or adaptive LED voltage. 01 Automatically managed irrespective of audio, adapting for low-power dissipation when LEDs are ON, and operating in Fixed-Boost Bypass Mode if LEDs are OFF (VBST = VP). 10 (Default) Boost voltage fixed in Bypass Mode (VBST = VP). 11 Boost voltage fixed at 5 V.

7.13 ADSP Control
Address 0x0F

R/W	7	6	5	4	3	2	1	0
	ADSP_DRIVE	M/S	DATCNF[1:0]		SHARE	—		
Default	0	0	1	0	0	0	0	0

Bits	Name	Description
7	ADSP_DRIVE	ADSP output drive strength. Selects the drive strength used for the ADSP outputs. These outputs include SDOUT as well as SCLK and LRCK when the device is in Master Mode. Table 3-8 lists drive-strength specifications. 0 (Default) 1x 1 0.5x
6	M/S	ADSP Master/Slave Mode. Configures the ADSP I/O clocking. See Section 4.11.2 for details. 0 (Default) Slave (SCLK/LRCK input only) 1 Master (SCLK/LRCK output only)
5:4	DATCNF	Data configuration for dual CS35L32 applications only. Determines the data packed in a two-CS35L32 configuration. 00 Left/right channels VMON[11:0], IMON[11:0], VPMON[7:0]. See Table 4-10 . 01 Left/right channels VMON[11:0], IMON[11:0], STATUS. See Table 4-11 . 10 (Default) left/right channels VMON[15:0], IMON [15:0]. See Table 4-12 . 11 Left/right channels VPMON[7:0], STATUS. See Table 4-13 .
3	SHARE	SDOUT sharing. Determines whether one or two CS35L32 devices are on board sharing SDOUT. 0 (Default) One IC. Data configuration per Table 4-9 . 1 Two ICs. For data configuration, refer to DATCNF (bits 5:4. above).
2:0	—	Reserved

7.14 Class D Amplifier Control
Address 0x10

R/W	7	6	5	4	3	2	1	0
	—		AMP_GAIN[2:0]		GAIN_CHG_ZC		—	
Default	0	0	0	1	0	1	0	0

Bits	Name	Description
7:6	—	Reserved
5:3	AMP_GAIN	Amplifier gain. Configures the amplifier gain. Step size: ~3 dB 000 Mute (–80 dB) 010 (Default) 12 dB 100 18 dB 001 9 dB 011 15 dB 101–111 Reserved
2	GAIN_CHG_ZC	Gain change zero-cross. Configures when AMP_GAIN (see p. 39) changes are applied. 0 Changes are not aligned to zero crosses. 1 (Default) Changes are delayed to occur at zero crossings
1:0	—	Reserved

7.15 Protection Release Control
Address 0x11

R/W	7	6	5	4	3	2	1	0
	—					AMP_SHORT_RLS	—	OTE_RLS
Default	0	0	0	0	0	0	0	0

Bits	Name	Description
7:3	—	Reserved
2	AMP_SHORT_RLS	Amplifier short protection release. Releases amplifier short protection that places the device into Speaker-Safe Mode if the amplifier short condition is no longer present, which can be determined by reading AMP_SHORT (see Section 7.19) twice. 0 (Default) If the amplifier short condition is present, Speaker-Safe Mode is applied. 1 0 → 1 → 0 sequence After the sequence, if the short condition is no longer present, Speaker-Safe Mode is cleared unless an OTE condition is active. During the sequence, short monitoring is inactive because the amplifier is in an OFF state, as explained in Section 7.19 . Short monitoring resumes after the sequence.
1	—	Reserved

Bits	Name	Description
0	OTE_RLS	Overtemperature error protection release. Releases (removes) OTE-caused Speaker-Safe Mode if the OTE condition is no longer present, which can be determined by reading OTE (see Section 7.19) twice. 0 (Default) If the OTE condition is present, Speaker-Safe Mode is applied. 1 0 → 1 → 0 sequence At the end of the sequence, if the OTE condition is no longer present, the Speaker-Safe Mode is cleared, unless an amplifier short cause is still active.

Note: For these bits, if the condition that causes automatic protection becomes true again during the protection potential release sequence (x_RLS: 0 → 1 → 0), protection is not removed, the related interrupt status bit is set again, and, if unmasked, a new interrupt is generated.

7.16 Interrupt Mask 1

Address 0x12

R/W	7	6	5	4	3	2	1	0
		—		M_ADSPCLK_ERR	M_MCLK_ERR	M_AMP_SHORT	M_OTW	M_OTE
Default	1	1	1	1	1	1	1	1

Interrupt mask register bits serve as a mask for the interrupt sources in the interrupt status registers. Interrupts are described in [Section 4.2](#).

Bits	Name	Description
7:5	—	Reserved
4	M_ADSPCLK_ERR	Error masks 0 Unmasked 1 (Default) Masked
3	M_MCLK_ERR	
2	M_AMP_SHORT	AMP_SHORT mask 0 Unmasked 1 (Default) Masked
1	M_OTW	OTW mask 0 Unmasked 1 (Default) Masked
0	M_OTE	OTE mask 0 Unmasked 1 (Default) Masked

7.17 Interrupt Mask 2

Address 0x13

R/W	7	6	5	4	3	2	1	0
	M_VMON_OVFL	M_IMON_OVFL	M_VPMON_OVFL		—			M_PDN_DONE
Default	1	1	1	1	1	1	1	1

Interrupt mask register bits serve as a mask for the interrupt sources in the interrupt status registers. Interrupts are described in [Section 4.2](#).

Bits	Name	Description
7	M_VMON_OVFL	Overflow masks 0 Unmasked 1 (Default) Masked
6	M_IMON_OVFL	
5	M_VPMON_OVFL	
4:1	—	Reserved
0	M_PDN_DONE	PDN_DONE mask 0 Unmasked 1 (Default) Masked

7.18 Interrupt Mask 3
Address 0x14

R/W	7	6	5	4	3	2	1	0
	M_UVLO	M_LED2_OPEN	M_LED2_SHORT	M_LED1_OPEN	M_LED1_SHORT	M_LOWBAT	M_BOOST_CURLIM	M_BOOST_OVERROR
Default	1	1	1	1	1	1	1	1

Interrupt mask register bits serve as a mask for the interrupt sources in the interrupt status registers. Interrupts are described in [Section 4.2](#). Registers at addresses 0x14–0x17 must not be part of a control-port autoincremented read and must be read individually. See [Section 4.14.1](#).

Bits	Name	Description
7	M_UVLO	UVLO mask 0 Unmasked 1 (Default) Masked
6	M_LED2_OPEN	LED 2/1 open and shorted masks 0 Unmasked 1 (Default) Masked
5	M_LED2_SHORT	
4	M_LED1_OPEN	
3	M_LED1_SHORT	
2	M_LOWBAT	Low battery mask 0 Unmasked 1 (Default) Masked
1	M_BOOST_CURLIM	Boost converter masks 0 Unmasked 1 (Default) Masked
0	M_BOOST_OVERROR	

7.19 Interrupt Status 1 (Audio)
Address 0x15

R/O	7	6	5	4	3	2	1	0
				ADSPCLK_ERR	MCLK_ERR	AMP_SHORT	OTW	OTE
Default	x	x	x	x	x	x	x	x

Interrupt mask register bits serve as a mask for the interrupt sources in the interrupt status registers. Interrupts are described in [Section 4.2](#). Registers at addresses 0x14–0x17 must not be part of a control-port autoincremented read and must be read individually. See [Section 4.14.1](#).

Bits	Name	Description
7:5	—	Reserved
4	ADSPCLK_ERR	ADSP clock error. Indicates that the ADSP has lost synchronization. See Section 4.11.2 and Section 7.7 for details. 0 (Default) MCLK _{INT} -to-LRCK ratio is valid. Valid if $f_{LRCK} = f_{MCLK(INT)/RATIO}$ 1 MCLK _{INT} -to-LRCK ratio is invalid. Set as the ADSP resynchronizes on initial power up and application of clocks.
3	MCLK_ERR	Master clock error. Indicates the MCLK watchdog status. 0 (Default) MCLK is above ~1.25 MHz. 1 MCLK is below ~1.25 MHz, so the device should be reset ($\overline{RESET} = HIGH \rightarrow LOW$), released from reset ($\overline{RESET} = LOW \rightarrow HIGH$) when a valid MCLK is reapplied, and restarted. If this condition exists, the Class D amplifier immediately stops switching and the outputs are internally clamped to ground. See Section 4.13.3 .
2	AMP_SHORT	Amplifier short. Indicates that either of the amplifier outputs (OUT±) is driving a short circuit. 0 (Default) Not shorted 1 Shorted. The device enters Speaker-Safe Mode (see Section 4.3.4). Normal behavior may resume when the short condition ceases and AMP_SHORT_RLS is sequenced, as described in Section 7.15 . Note: The circuit feeding this bit requires the amplifier to be fully powered and not in shut-down mode; if it is powered down (PDN_AMP = 1) or in Speaker-Safe Mode, the detector indicates no short condition, even if speaker outputs are shorted.
1	OTW	Overtemperature warning. Indicates that device junction temperature exceeded the set limit, as described in Table 3-3 . 0 (Default) Below set overtemperature warning threshold 1 Above set overtemperature warning threshold
0	OTE	Overtemperature error. Indicates whether the device junction temperature exceeded the damage limit. 0 (Default) Below damage limit 1 Above damage limit. The device enters Speaker-Safe Mode (see Section 4.3.4). Normal behavior may resume when the OTE event ends and OTE_RLS is sequenced, as described in Section 7.15 .

7.20 Interrupt Status 2 (Monitors)
Address 0x16

R/O	7	6	5	4	3	2	1	0
	VMON_OVFL	IMON_OVFL	VPMON_OVFL		—			PDN_DONE
Default	x	x	x	x	x	x	x	x

Interrupt status bits are read only and sticky. Interrupts are described in [Section 4.2](#). Registers at addresses 0x14–0x17 must not be part of a control-port autoincremented read and must be read individually. See [Section 4.14.1](#).

Bits	Name	Description
7	VMON_OVFL	xMON overflow. Indicates the overrange status in the VMON, IMON, or VPMON ADC signal path
6	IMON_OVFL	0 (Default) No clipping has occurred anywhere in the ADC signal path 1 Clipping has occurred in the ADC signal path
5	VPMON_OVFL	The programming of IMON_SCALE may cause IMON_OVFL to be set.
4:1	—	Reserved
0	PDN_DONE	Power-down done. Indicates whether the CS35L32 has completely powered down and MCLK can be stopped. 0 Not completely powered down. PDN_DONE = 0 if any blocks require MCLK _{INT} . After powering down using PDN_ALL or discrete power-down bits, the CS35L32 transitions to a powered-down state, after which, PDN_DONE is set and MCLK _{INT} can be removed. 1 (Default) Powered down

7.21 Interrupt Status 3 (LEDs and Boost Converter)
Address 0x17

R/O	7	6	5	4	3	2	1	0
	UVLO	LED2_OPEN	LED2_SHORT	LED1_OPEN	LED1_SHORT	LOWBAT	BOOST_CURLIM	BOOST_OVERROR
Default	x	x	x	x	x	x	x	x

Interrupt status bits are read only and sticky. Interrupts are described in [Section 4.2](#). Registers at addresses 0x14–0x17 must not be part of a control-port autoincremented read and must be read individually. See [Section 4.14.1](#).

Bits	Name	Description
7	UVLO	UVLO event 0 (Default) No lockout 1 UVLO detected at VP. IC shutdown.
6	LED2_OPEN	LED 2 open 0 (Default) No open detected 1 Open detected
5	LED2_SHORT	LED 2 shorted 0 (Default) No short detected 1 short detected
4	LED1_OPEN	LED 1 open 0 (Default) No open detected 1 Open detected
3	LED1_SHORT	LED 1 shorted 0 (Default) No short detected 1 Short detected
2	LOWBAT	Battery voltage (VP) is low. This bit is updated only during an active Flash LED event. Reads to clear this bit between any two sequential Flash Events are not be reflected in the status register until the next active Flash Event is triggered. 0 (Default) Battery voltage normal (above LOWBAT_TH, see Section 7.8) 1 Battery voltage low (below LOWBAT_RECOV, see Section 7.8)
1	BOOST_CURLIM	Boost converter in current limit 0 (Default) Not in current limit 1 Boost current has exceeded level programmed in BST_IPK
0	BOOST_OVERROR	Boost converter overvoltage error 0 (Default) No overvoltage 1 Overvoltage

7.22 LED Lighting Status
Address 0x18

R/O	7	6	5	4	3	2	1	0
	LED1_FLEV	LED2_FLEV	LED1_MVEV	LED2_MVEV	LED_FLEN	LED_FLINH	LED2_DIS	LED_TIMERON
Default	x	x	x	x	x	x	x	x

Bits	Name	Description
7	LED1_FLEV	LED1 flash event 0 (Default) No driver flash current to LED 1 Flash current delivered to LED
6	LED2_FLEV	LED2 flash event 0 (Default) No driver flash current to LED 1 Flash current delivered to LED
5	LED1_MVEV	LED1 Movie Mode event 0 (Default) No driver movie current to LED 1 Movie current delivered to LED
4	LED2_MVEV	LED2 Movie Mode event 0 (Default) No driver movie current to LED 1 Movie current delivered to LED
3	LED_FLEN	Flag mirroring FLEN 0 (Default) FLEN low 1 FLEN high
2	LED_FLINH	Flag mirroring FLINH 0 (Default) FLINH low 1 FLINH high
1	LED2_DIS	LED2 disabled status reporting the use of FLOUT2 as AD0, with no LED, and tied to ground 0 (Default) Enabled 1 Disabled (tied to ground)
0	LED_TIMERON	Flash timer. Flag indicating the status of the flash timer. 0 (Default) Timer off 1 Timer on

7.23 LED Flash Mode Current
Address 0x19

R/W	7	6	5	4	3	2	1	0
			—			LED_FLCUR[3:0]		
Default	0	0	0	0	0	0	0	0

Bits	Name	Description
7:4	—	Reserved
3:0	LED_FLCUR	LED flash driver current in 50-mA increments. Note: If an open-circuit condition occurs on one FLOUTx pin, the current through the other FLOUTx pin is 50 mA lower than the LED_FLCUR programmed value. 0000 (Default) OFF 0111 350 mA 1001 450 mA 1011 550 mA 1101 650 mA 1111 750 mA 0001–0110 Reserved 1000 400 mA 1010 500 mA 1100 600 mA 1110 700 mA

7.24 LED Movie Mode Current
Address 0x1A

R/W	7	6	5	4	3	2	1	0
	—	LED_MVCUR[2:0]			—	—	LED1_MVEN	LED2_MVEN
Default	0	0	0	0	0	0	0	0

Bits	Name	Description
7	—	Reserved
6:4	LED_MVCUR	LED Movie Mode drive current. 000 (Default) OFF 010 40 mA 100 80 mA 110 120 mA 001 20 mA 011 60 mA 101 100 mA 111 150 mA
3:2	—	Reserved
1	LED1_MVEN	Enable LED 1 in Movie Mode 0 (Default) Disable LED 1 1 Enable LED 1
0	LED2_MVEN	Enable LED 2 in Movie Mode 0 (Default) Disable LED 2 1 Enable LED 2

7.25 LED Flash Timer
Address 0x1B

R/W	7	6	5	4	3	2	1	0
	—	TIMER[4:0]				—	—	TIMEOUT_MODE
Default	0	0	1	0	0	1	0	0

Bits	Name	Description
7:6	—	Reserved
5:1	TIMER	Determines the ON time of the flash timer. (Step Size = 25 * MCLK _{INT} /6 MHz ms) 0 0000 300000/MCLK _{INT} s 0 0111 1350000/MCLK _{INT} s 0 1110 2400000/MCLK _{INT} s 0 0001 450000/MCLK _{INT} s 0 1000 1500000/MCLK _{INT} s 0 1111 2550000/MCLK _{INT} s 0 0010 600000/MCLK _{INT} s 0 1001 1650000/MCLK _{INT} s 1 0000 2700000/MCLK _{INT} s 0 0011 750000/MCLK _{INT} s 0 1010 1800000/MCLK _{INT} s 0 0001 2850000/MCLK _{INT} s 0 0100 900000/MCLK _{INT} s 0 1011 1950000/MCLK _{INT} s 1 0010 3000000/MCLK _{INT} s (Default) 0 0101 1050000/MCLK _{INT} s 0 1100 2100000/MCLK _{INT} s 1 0011–1 11113000000/MCLK _{INT} s 0 0110 1200000/MCLK _{INT} s 0 1101 2250000/MCLK _{INT} s
0	TIMEOUT_MODE	Flash timeout mode 0 (Default) Flash timer (TIMERON) determines end of flash irrespective of the FLEN input pin. 1 End of flash determined by either FLEN going low or flash timer timing out.

7.26 LED Flash Inhibit Current
Address 0x1C

R/W	7	6	5	4	3	2	1	0
	—	—	LED_FLINHCUR[3:0]			—	—	—
Default	0	0	0	0	0	0	0	0

Bits	Name	Description
7:4	—	Reserved
3:0	LED_FLINHCUR	LED flash driver current in 50-mA increments. 0000 (Default) OFF 0011 150 mA 0110 300 mA 0001 50 mA... 0100 200 mA 0111 350 mA 0010 100 mA 0101 250 mA 1000–1111 Reserved

8 Typical Performance Plots

8.1 System-Level Efficiency and Power-Consumption Plots

For all system-level efficiency and power-consumption plots, a simulated speaker load ($8\ \Omega + 33\ \mu\text{H}$) is used; the amplifier PWM outputs (OUT_{\pm}) contain no EMI filtering. Efficiency calculations are based on RMS power delivered to the load at the generated frequency and include power consumption of both VA and VP.

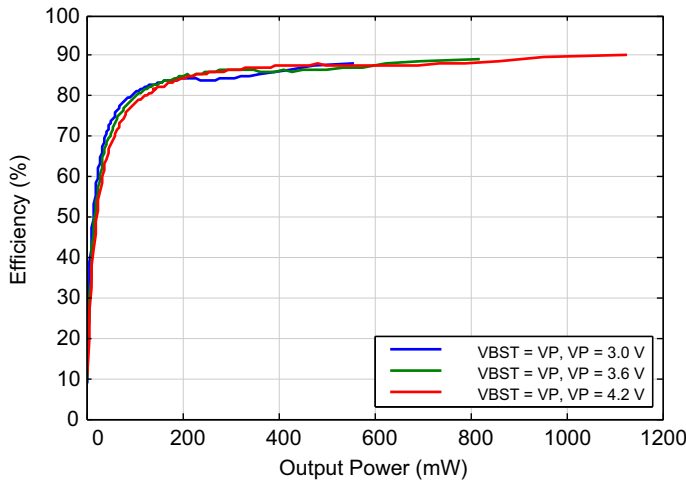

Figure 8-1. Efficiency vs. Output Power—VBST = VP (VP = 3.0 V, VP = 3.6 V, VP = 4.2 V)

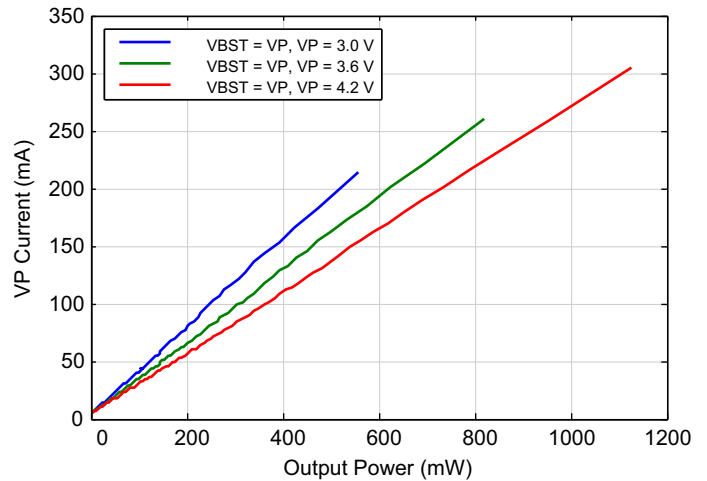

Figure 8-2. VP Supply Current vs. Output Power—VBST = VP (VP = 3.0 V, VP = 3.6 V, VP = 4.2 V)

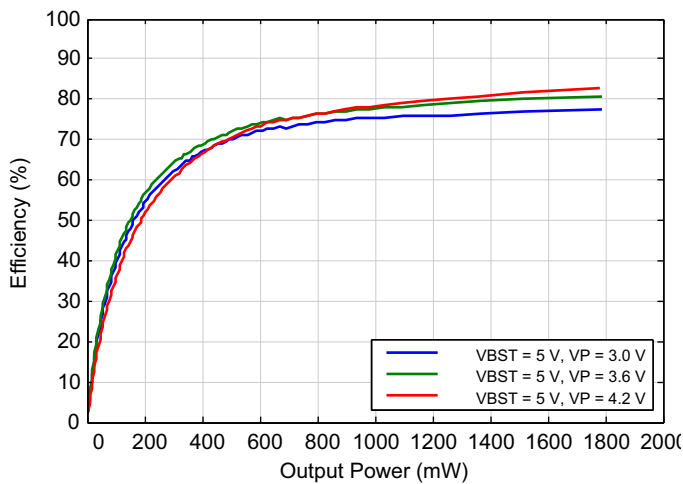

Figure 8-3. Efficiency vs. Output Power—VBST = 5.0 V (VP = 3.0 V, VP = 3.6 V, VP = 4.2 V)

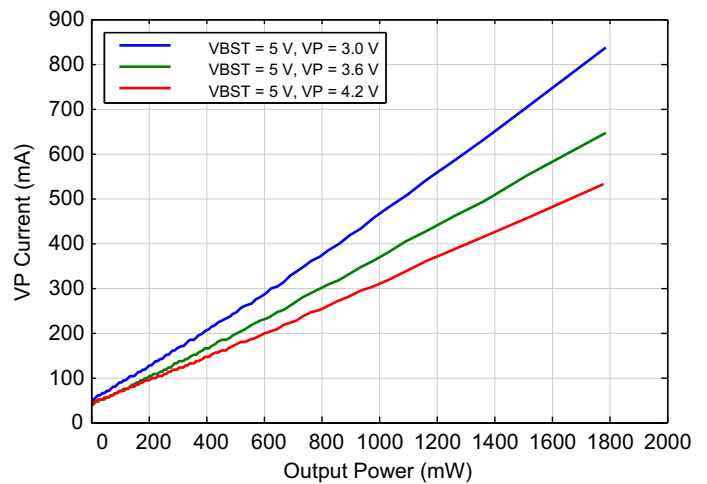

Figure 8-4. VP Supply Current vs. Output Power—VBST = 5.0 V (VP = 3.0 V, VP = 3.6 V, VP = 4.2 V)

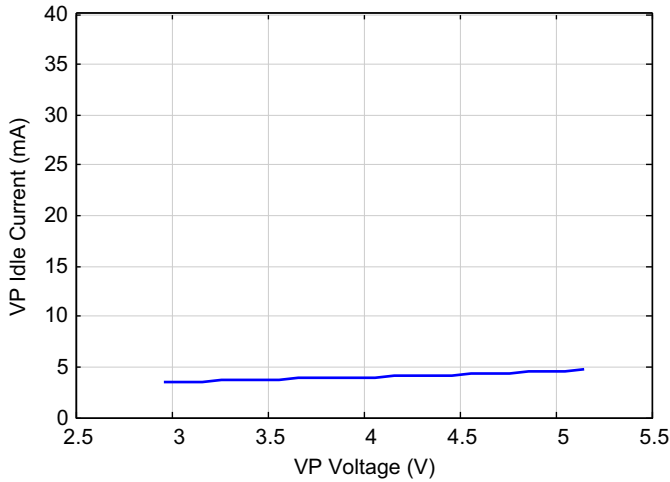

Figure 8-5. Device Idle Power Consumption, Current vs. VP—
VBST = 5.0 V, VBST = VP = 3.6 V

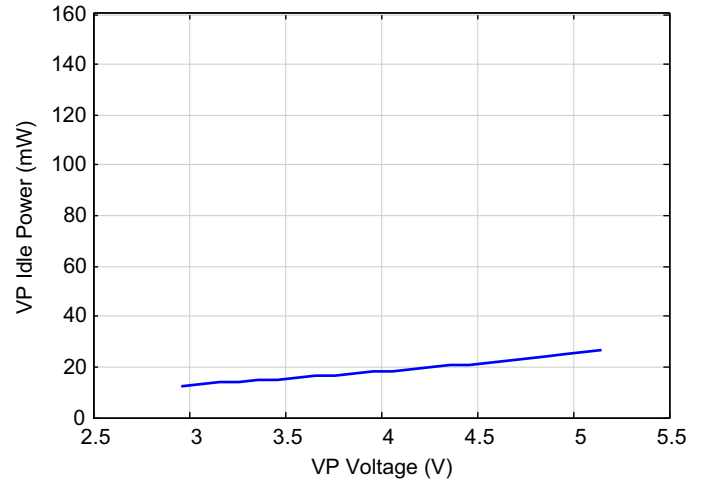

Figure 8-6. Device Idle Power Consumption, Power vs. VP—
VBST = 5.0 V, VBST = VP = 3.6 V

8.2 Audio Output Typical Performance Plots

To avoid nonlinearities (distortion) introduced by the amplifier load inductor itself, all amplifier typical performance plots use a resistor and not a simulated speaker load. No EMI filtering is populated on the amplifier outputs (OUT±).

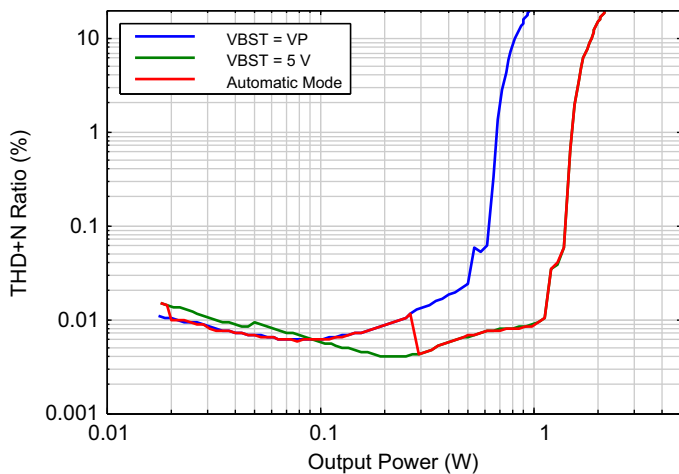

Figure 8-7. THD+N Ratio vs. Output Power @ 1 kHz, 8 Ω—
Bypass Mode (VBST = VP = 3.6 V),
Fixed Boost Mode (VBST = 5 V), Automatic Mode

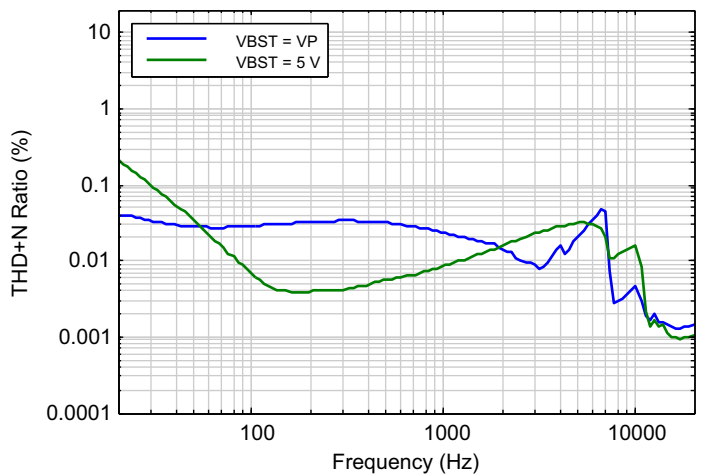

Figure 8-8. THD+N Ratio vs. Frequency, 8 Ω—
Bypass Mode (VBST = VP = 3.6 V, Load = 0.5 W),
Fixed Boost Mode (VBST = 5 V, Load = 1 W)

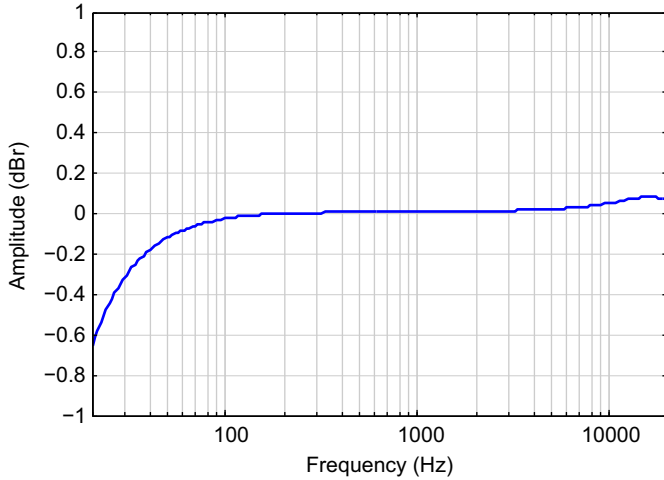

Figure 8-9. Frequency Response @ 1 W—Fixed-Boost Mode (VBST = 5 V, Refer to Amplitude @ 1 kHz)

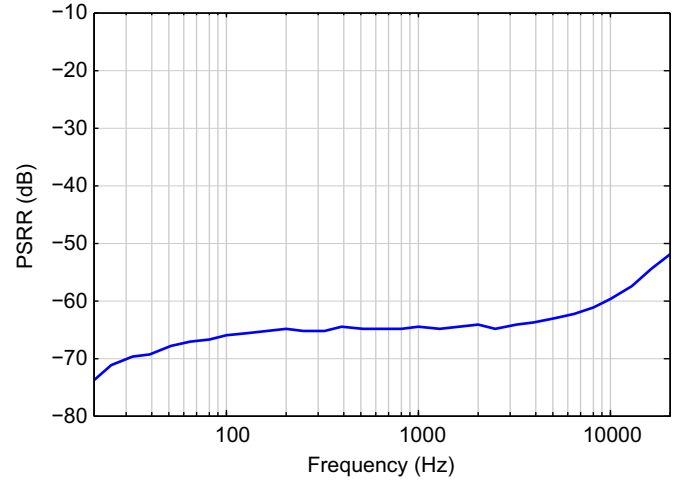

Figure 8-10. VP PSRR Vs. Frequency, VP_ac = 100 mVpk—Bypass Mode (VBST = VP), Fixed-Boost Mode (VBST = 5 V)

8.3 Monitoring Typical Performance Plots

Unless otherwise noted, all VMON/IMON plots use the amplifier as the signal source and all measurements were taken using an $8\ \Omega + 33\ \mu\text{H}$ load. All listed load inductances include any measured inductances contained in the connection to the load. No EMI filtering is populated on the amplifier outputs ($\text{OUT}\pm$).

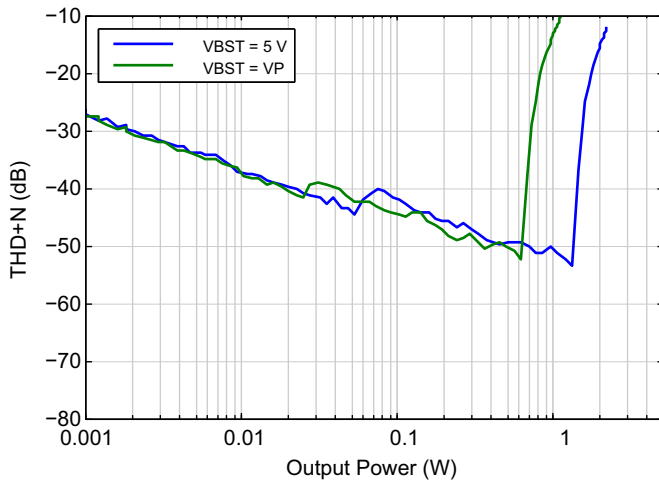

Figure 8-11. IMON THD+N Ratio vs. Amplifier Output Power @ 1 kHz—Bypass Mode (VBST = VP = 3.6 V, Load = 0.5 W) Fixed Boost Mode (VBST = 5 V, Load = 1 W)

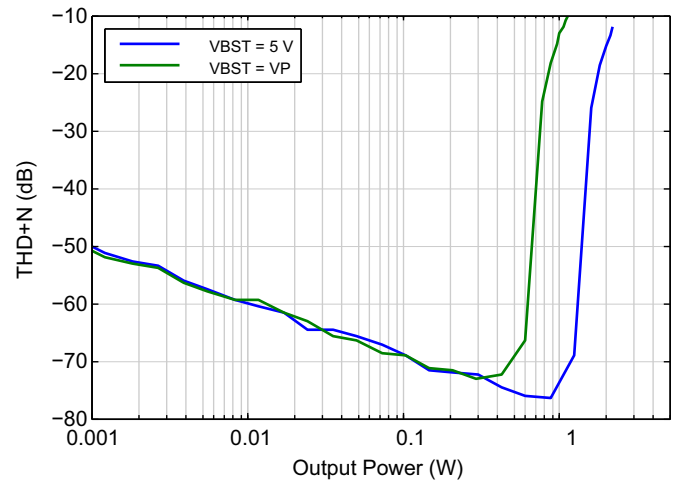
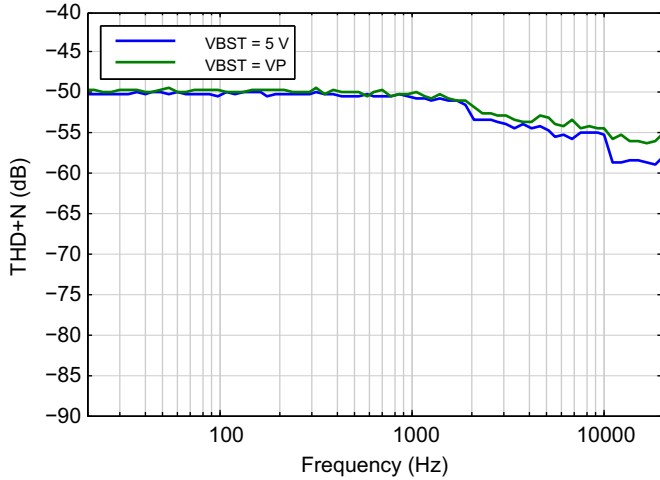
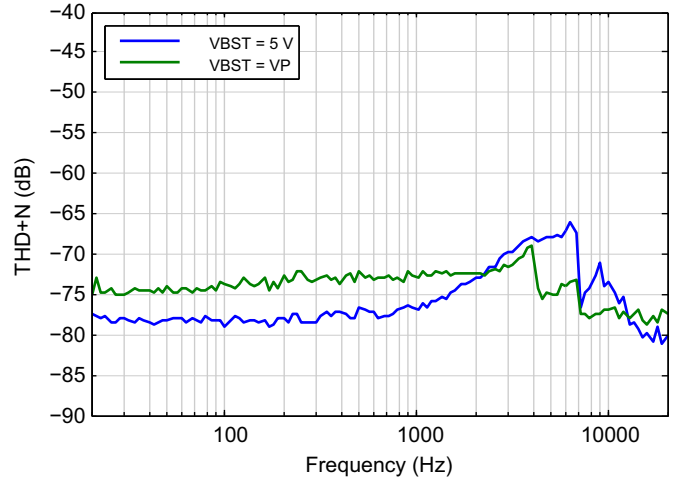

Figure 8-12. VMON THD+N Ratio vs. Amplifier Output Power @ 1 kHz—Bypass Mode (VBST = VP = 3.6 V, Load = 0.5 W) Fixed Boost Mode (VBST = 5 V, Load = 1 W)



**Figure 8-13. IMON THD+N Ratio vs. Frequency—
Bypass Mode (VBST = VP = 3.6 V, Load = 0.5 W)
Fixed Boost Mode (VBST = 5 V, Load = 1 W)**



**Figure 8-14. VMON THD+N Ratio vs. Frequency—
Bypass Mode (VBST = VP = 3.6 V, Load = 0.5 W)
Fixed Boost Mode (VBST = 5 V, Load = 1 W)**

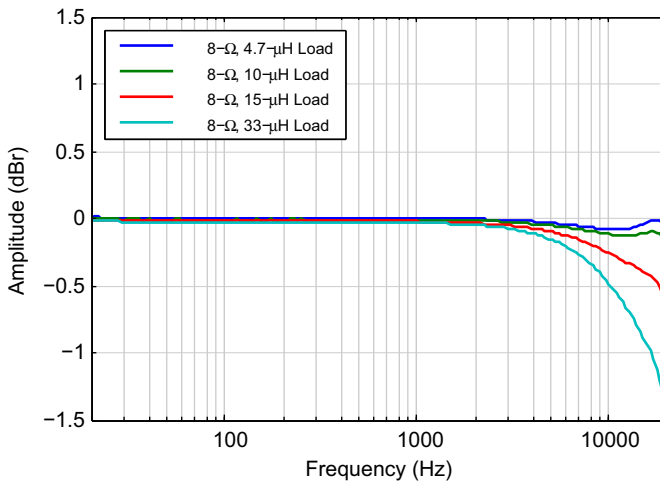

**Figure 8-15. IMON Frequency Response @ 1 W—
Fixed-Boost Mode (VBST = 5 V)**

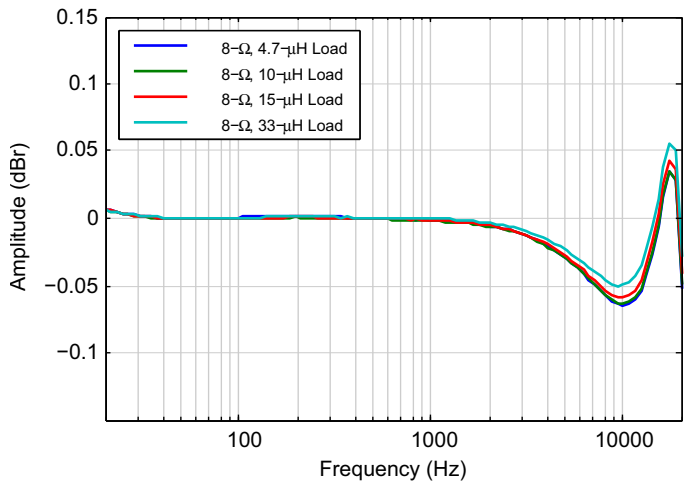

**Figure 8-16. VMON Frequency Response @ 1 W—
Fixed-Boost Mode (VBST = 5 V)**

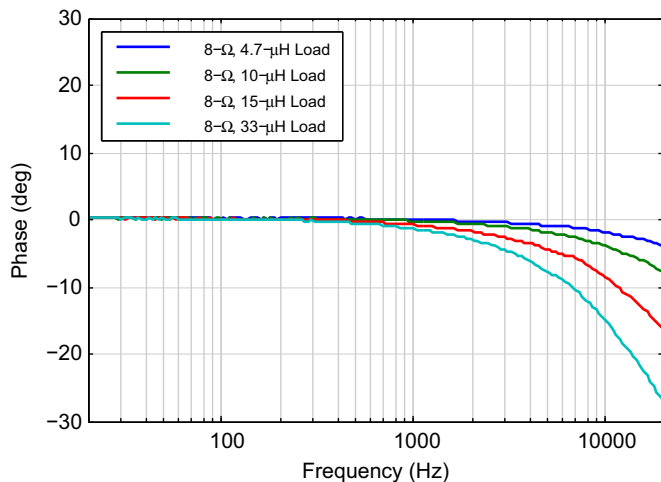

Figure 8-17. VMON to IMON Phase vs. Frequency @ 1 W—Fixed-Boost Mode (VBST = 5 V)

Load = 8 Ω + 5 μH, 8 Ω + 10 μH, 8 Ω + 33 μH, 8 Ω + 15 μH

1

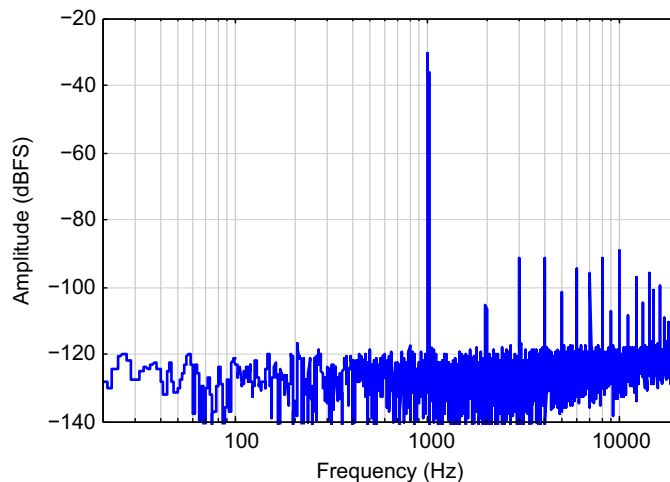

Figure 8-18. IMON FFT, 1 kHz @ Load = 0.9 W—VBST = 5 V

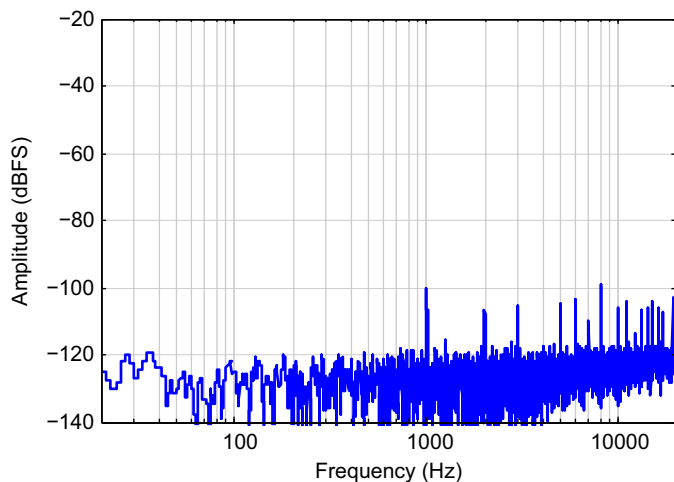

Figure 8-19. IMON FFT, 1 kHz @ No load—VBST = 5 V

9 Parameter Definitions

MCLK_{INT}. Internal clock that is either equal to the signal connected to the MCLK (MCLK_{EXT}) or is equal to MCLK_{EXT}/2, depending on the setting of the MCLK divide-by-2 control (MCLKDIV2), described in [Section 7.7](#).

Output offset voltage. Describes the DC offset voltage present at the amplifier's output when its input signal is in a Mute State. The offset exists due to CMOS process limitations and is proportional to analog volume settings. When measuring the offset out of the line amplifier, the line amplifier is ON and the headphone amplifier is OFF; when measuring the offset out of the headphone amplifier, the headphone amplifier is ON and the line amplifier is OFF.

Signal-to-noise ratio (SNR). The ratio of the RMS value of the output signal, where P_{out} is equivalent to the specified output power at THD+N < 1%, to the RMS value of the noise floor with no input signal applied and measured over the specified bandwidth, typically 20 Hz to 20 kHz. This measurement technique has been accepted by the Electronic Industries Association of Japan, EIAJ CP-307. Expressed in decibels.

Total harmonic distortion + noise (THD+N). The ratio of the rms value of the signal to the rms sum of all other spectral components over the specified bandwidth (typically 10 Hz to 20 kHz), including distortion components. THD+N is measured at -1 and -20 dBFS for the analog input and 0 and -20 dB for the analog output as suggested in AES17-1991 Annex A. THD+N is expressed in decibel units.

10 Package Dimensions

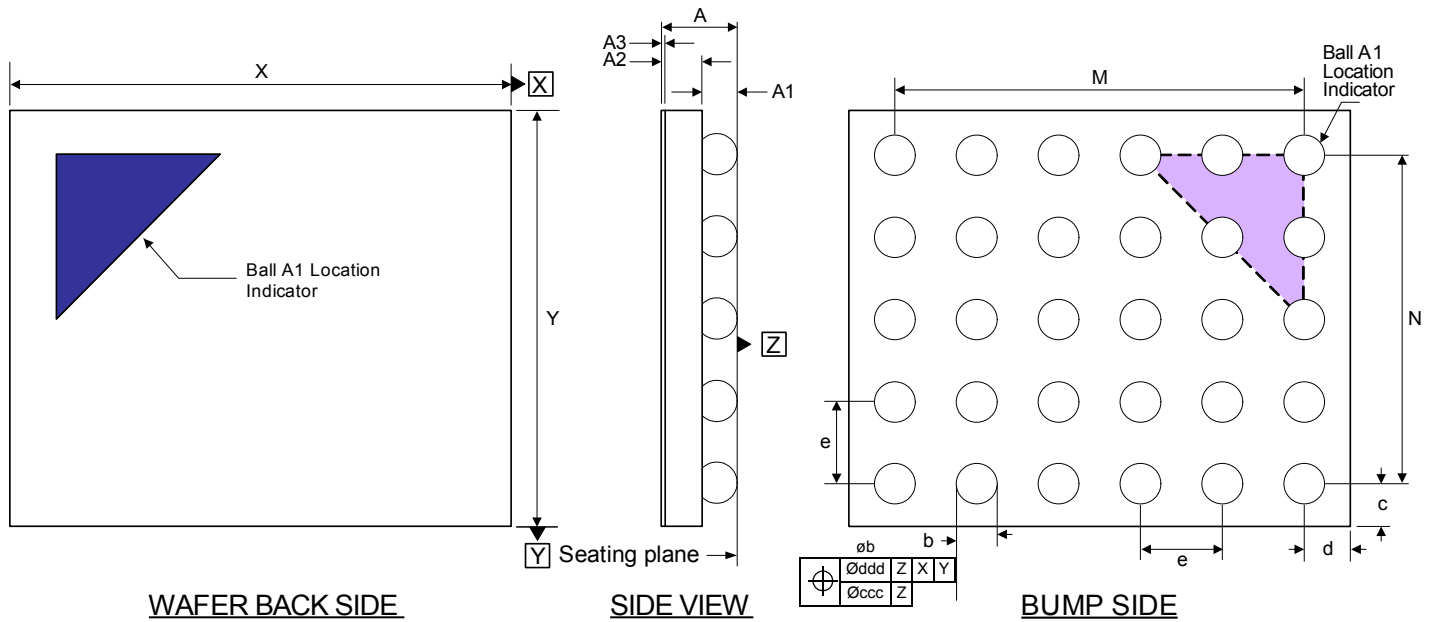

Notes:

- Dimensioning and tolerances per ASME Y 14.5M–1994.
- The Ball A1 position indicator is for illustration purposes only and may not be to scale.
- Dimension “b” applies to the solder sphere diameter and is measured at the midpoint between the package body and the seating plane Datum Z.
- Dimension A3 describes the thickness of the backside film.

Table 10-1. WLCSP Package Dimensions

Dimension	Millimeters		
	Minimum	Nominal	Maximum
A	0.451	0.494	0.537
A1	0.169	0.194	0.219
A2	0.275	0.3	0.325
A3	0.022	0.025	0.028
M	BSC	2.000	BSC
N	BSC	1.600	BSC
b	0.243	0.268	0.293
c	REF	0.264	REF
d	REF	0.295	REF
e	BSC	0.400	BSC
X	2.560	2.590	2.620
Y	2.108	2.138	2.168
ccc = 0.10			
ddd = 0.05			

Note: Controlling dimension is millimeters.

Figure 10-1. 30-Ball WLCSP Package Drawing

11 Thermal Characteristics

Table 11-1. Thermal Resistance

Parameters	Symbol	Min	Typical	Max	Units
Junction-to-ambient thermal impedance	θ_{JA}	—	50	—	°C/Watt

12 Ordering Information

Table 12-1. Ordering Information

Product	Description	Package	Halogen Free	Pb Free	Grade	Temperature Range	Container	Order Number
CS35L32	Boosted Class D Amplifier with Speaker-Protection Monitoring and Flash LED Drivers	30-ball WLCSP	Yes	Yes	Commercial	-10°C to 70°C	Tape and Reel	CS35L32-CWZR

13 References

1. NXP Semiconductors (founded by Philips Semiconductor), *The I²C-Bus Specification and User Manual*. UM10204 Rev. 03, June 19, 2007 <http://www.nxp.com>

14 Revision History

Table 14-1. Revision History

Date	Changes
F2 MAR '14	• Updated values for Boost FET peak-current limit in Table 3-4 .
F3 MAY '14	• Updated the maximum value for VBST in Table 3-4 .
F4 JUL '14	• Updated package dimensions in Table 10-1 .
F5 AUG '15	• Updated package dimensions in Table 10-1 and package drawing to include backside film. • Updated legal disclaimer.

Contacting Cirrus Logic Support

For all product questions and inquiries, contact a Cirrus Logic Sales Representative.

To find one nearest you, go to www.cirrus.com.

IMPORTANT NOTICE

The products and services of Cirrus Logic International (UK) Limited; Cirrus Logic, Inc.; and other companies in the Cirrus Logic group (collectively either "Cirrus Logic" or "Cirrus") are sold subject to Cirrus Logic's terms and conditions of sale supplied at the time of order acknowledgment, including those pertaining to warranty, indemnification, and limitation of liability. Software is provided pursuant to applicable license terms. Cirrus Logic reserves the right to make changes to its products and specifications or to discontinue any product or service without notice. Customers should therefore obtain the latest version of relevant information from Cirrus Logic to verify that the information is current and complete. Testing and other quality control techniques are utilized to the extent Cirrus Logic deems necessary. Specific testing of all parameters of each device is not necessarily performed. In order to minimize risks associated with customer applications, the customer must use adequate design and operating safeguards to minimize inherent or procedural hazards. Cirrus Logic is not liable for applications assistance or customer product design. The customer is solely responsible for its selection and use of Cirrus Logic products.

CERTAIN APPLICATIONS USING SEMICONDUCTOR PRODUCTS MAY INVOLVE POTENTIAL RISKS OF DEATH, PERSONAL INJURY, OR SEVERE PROPERTY OR ENVIRONMENTAL DAMAGE ("CRITICAL APPLICATIONS"). CIRRUS LOGIC PRODUCTS ARE NOT DESIGNED, AUTHORIZED OR WARRANTED FOR USE IN PRODUCTS SURGICALLY IMPLANTED INTO THE BODY, AUTOMOTIVE SAFETY OR SECURITY DEVICES, NUCLEAR SYSTEMS, LIFE SUPPORT PRODUCTS OR OTHER CRITICAL APPLICATIONS. INCLUSION OF CIRRUS LOGIC PRODUCTS IN SUCH APPLICATIONS IS UNDERSTOOD TO BE FULLY AT THE CUSTOMER'S RISK AND CIRRUS LOGIC DISCLAIMS AND MAKES NO WARRANTY, EXPRESS, STATUTORY OR IMPLIED, INCLUDING THE IMPLIED WARRANTIES OF MERCHANTABILITY AND FITNESS FOR PARTICULAR PURPOSE, WITH REGARD TO ANY CIRRUS LOGIC PRODUCT THAT IS USED IN SUCH A MANNER. IF THE CUSTOMER OR CUSTOMER'S CUSTOMER USES OR PERMITS THE USE OF CIRRUS LOGIC PRODUCTS IN CRITICAL APPLICATIONS, CUSTOMER AGREES, BY SUCH USE, TO FULLY INDEMNIFY CIRRUS LOGIC, ITS OFFICERS, DIRECTORS, EMPLOYEES, DISTRIBUTORS AND OTHER AGENTS FROM ANY AND ALL LIABILITY, INCLUDING ATTORNEYS' FEES AND COSTS, THAT MAY RESULT FROM OR ARISE IN CONNECTION WITH THESE USES.

This document is the property of Cirrus Logic and by furnishing this information, Cirrus Logic grants no license, express or implied, under any patents, mask work rights, copyrights, trademarks, trade secrets or other intellectual property rights. Any provision or publication of any third party's products or services does not constitute Cirrus Logic's approval, license, warranty or endorsement thereof. Cirrus Logic gives consent for copies to be made of the information contained herein only for use within your organization with respect to Cirrus Logic integrated circuits or other products of Cirrus Logic, and only if the reproduction is without alteration and is accompanied by all associated copyright, proprietary and other notices and conditions (including this notice). This consent does not extend to other copying such as copying for general distribution, advertising or promotional purposes, or for creating any work for resale. This document and its information is provided "AS IS" without warranty of any kind (express or implied). All statutory warranties and conditions are excluded to the fullest extent possible. No responsibility is assumed by Cirrus Logic for the use of information herein, including use of this information as the basis for manufacture or sale of any items, or for infringement of patents or other rights of third parties. Cirrus Logic, Cirrus, the Cirrus Logic logo design, and SoundClear are among the trademarks of Cirrus Logic. Other brand and product names may be trademarks or service marks of their respective owners.

Copyright © 2012–2015 Cirrus Logic, Inc. All rights reserved.

Mouser Electronics

Authorized Distributor

Click to View Pricing, Inventory, Delivery & Lifecycle Information:

[Cirrus Logic:](#)

[CS35L32-CWZR](#)



Стандарт Электрон Связь

Мы молодая и активно развивающаяся компания в области поставок электронных компонентов. Мы поставляем электронные компоненты отечественного и импортного производства напрямую от производителей и с крупнейших складов мира.

Благодаря сотрудничеству с мировыми поставщиками мы осуществляем комплексные и плановые поставки широчайшего спектра электронных компонентов.

Собственная эффективная логистика и склад в обеспечивает надежную поставку продукции в точно указанные сроки по всей России.

Мы осуществляем техническую поддержку нашим клиентам и предпродажную проверку качества продукции. На все поставляемые продукты мы предоставляем гарантию .

Осуществляем поставки продукции под контролем ВП МО РФ на предприятия военно-промышленного комплекса России , а также работаем в рамках 275 ФЗ с открытием отдельных счетов в уполномоченном банке. Система менеджмента качества компании соответствует требованиям ГОСТ ISO 9001.

Минимальные сроки поставки, гибкие цены, неограниченный ассортимент и индивидуальный подход к клиентам являются основой для выстраивания долгосрочного и эффективного сотрудничества с предприятиями радиоэлектронной промышленности, предприятиями ВПК и научно-исследовательскими институтами России.

С нами вы становитесь еще успешнее!

Наши контакты:

Телефон: +7 812 627 14 35

Электронная почта: sales@st-electron.ru

Адрес: 198099, Санкт-Петербург,
Промышленная ул, дом № 19, литера Н,
помещение 100-Н Офис 331