



## **Ferrites and accessories**

RM 4, RM 4 LP  
Cores and accessories

**Series/Type:** B65803, B65804, B65806, B65539

**Date:** June 2013

To IEC 62317-4  
 Core without center hole  
 for transformer applications  
 Delivery mode: sets

**Magnetic characteristics (per set)**

	with center hole	without center hole	
$\Sigma l/A$	1.9	1.7	mm <sup>-1</sup>
$l_e$	21	22	mm
$A_e$	11	13	mm <sup>2</sup>
$A_{min}$	—	11.3	mm <sup>2</sup>
$V_e$	231	286	mm <sup>3</sup>

**Approx. weight (per set)**

m	1.45	1.65	g

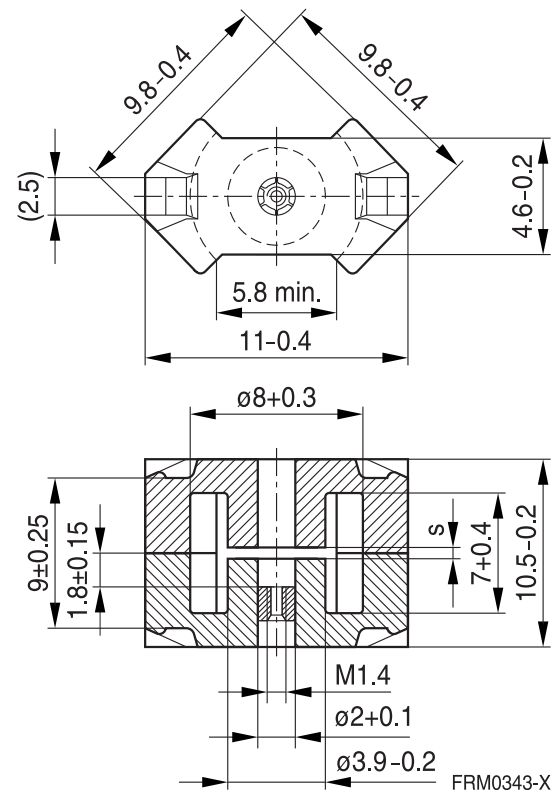
**Gapped**

Material	$A_L$ value	s approx. mm	$\mu_e$	Ordering code <sup>1)</sup> -A with center hole -N with threaded sleeve
	nH			
K1	16 ±3%	1.0	24.2	B65803+0016A001
	25 ±3%	0.40	37.8	B65803+0025A001
M33	40 ±3%	0.36	60.4	B65803+0040A033
	63 ±3%	0.18	96	B65803+0063A033
N48	63 ±3%	0.16	96	B65803+0063A048
	100 ±3%	0.10	152	B65803+0100A048
	160 ±3%	0.06	243	B65803+0160A048

1) Replace the + by the code letter "A" or "N" for the required version.

**Ungapped**

Material	A <sub>L</sub> value nH	μ <sub>e</sub>	P <sub>V</sub> W/set	Ordering code -J without center hole
N45	1700 +30/-20%	2290		B65803J0000R045
N30	1900 +30/-20%	2560		B65803J0000R030
T35	2800 +40/-30%	3770		B65803J0000Y035
T38	3700 +40/-30%	4980		B65803J0000Y038
N49	750 +30/-20%	1010	< 0.04 ( 50 mT, 500 kHz, 100 °C)	B65803J0000R049
N87	1100 +30/-20%	1480	< 0.20 (200 mT, 100 kHz, 100 °C)	B65803J0000R087
N97	1100 +30/-20%	1480	< 0.15 (200 mT, 100 kHz, 100 °C)	B65803J0000R097

**Coil former**

Material: GFR thermosetting plastic (UL 94 V-0, insulation class to IEC 60085:  
 $H \triangleq$  max. operating temperature 180 °C), color code white  
 Bakelite UP 3420® [E61040 (M)], HEXION SPECIALTY CHEMICALS GMBH

Solderability: to IEC 60068-2-20, test Ta, method 1 (aging 3): 235 °C, 2 s

Resistance to soldering heat: to IEC 60068-2-20, test Tb, method 1B: 350 °C, 3.5 s

Winding: see Data Book 2013, chapter "Processing notes, 2.1"

Pins squared in the start-of-winding area.  
 For matching clamp and insulating washers see page 5.

Sections	$A_N$ mm <sup>2</sup>	$l_N$ mm	$A_R$ value $\mu\Omega$	Pins	Ordering code
1	7.7	20	89	5 6	B65804P1005D001 B65804D1006D001

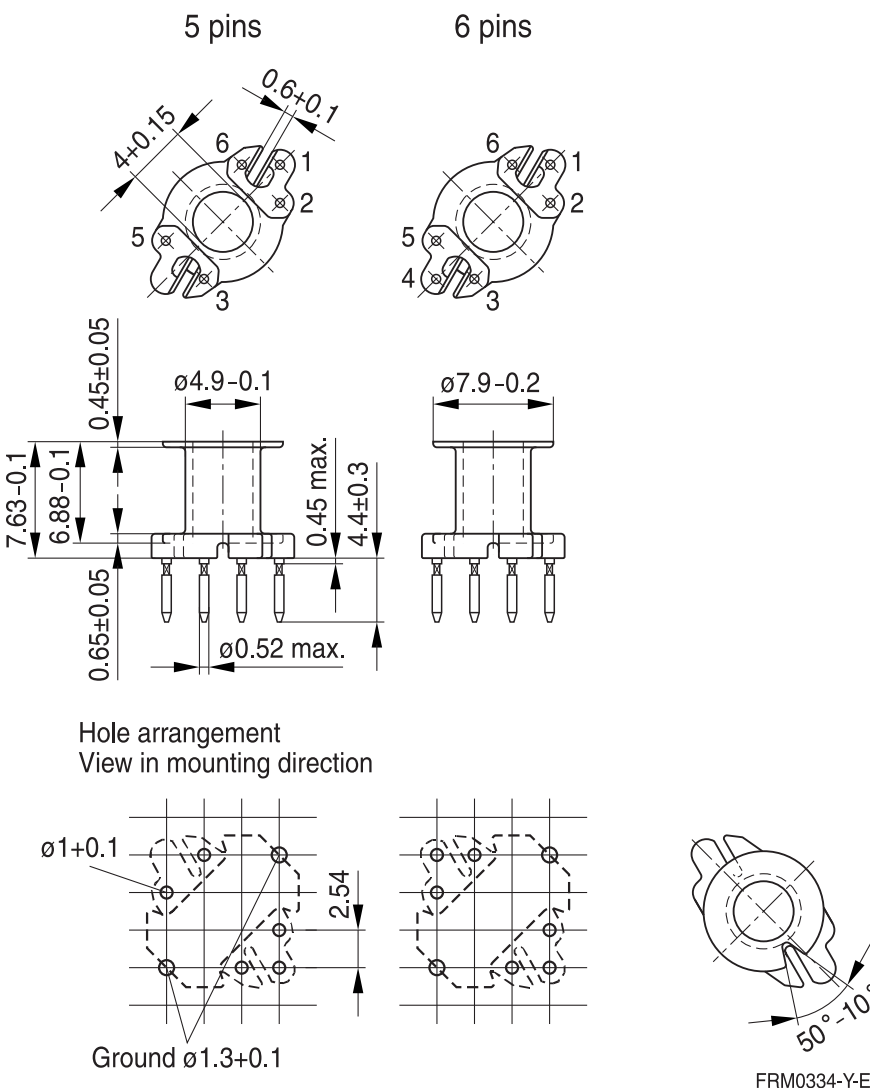

**Clamp**

With ground terminal, made of stainless spring steel (tinned), 0.3 mm thick  
 Solderability to IEC 60068-2-20, test Ta, method 1 (aging 3): 235 °C, 2 s  
 Also available as strip clamp on reels on request

**Insulating washer for double-clad PCBs**

Made of polycarbonate (UL 94 V-0, insulation class to IEC 60085: E  $\geq$  120 °C), 0.3 mm thick  
 Makrofol FR7-2, [E118859 (M)], natural color, BAYER MATERIALSCIENCE AG

	Ordering code
Clamp (ordering code per piece, 2 are required)	B65806B2203X000
Insulating washer (bulk)	B65804C2005X000

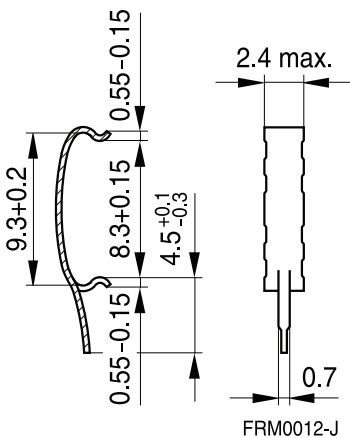
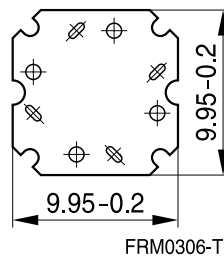
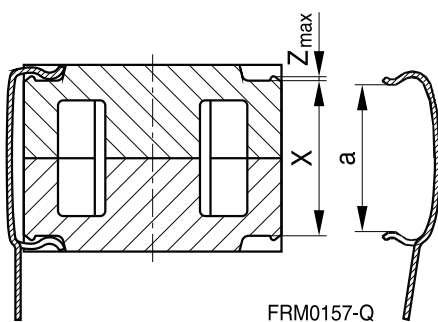
**Clamp**

**Insulating washer**

**Clamping forces for RM 4**

$F_{min}$ : Extension of clamp from  $a$  to  $a_2 = X_{min}$   
 $F_{max}$ : Extension of clamp from  $a$  to  $a_1 = X_{max}$

Clamp opening $a$ (mm)		8.3 +0.15
Core nose $Z_{max}$ (mm)		0.15
Height of core pair $X$ (mm)	$X_{min}$	8.75
	$X_{max}$	9.25
Clamping force $F$ (N)	$F_{min}$	5
	$F_{max}$	40

**Adjusting screw**

Tube core with thread and core brake made of GFR polyterephthalate  
 Pocan B3235® [E245249 (M)], LANXESS AG

Figure	Tube core			Ordering code
	Ø × length (mm)	Material	Color code	
a	1.81 × 2.0	K1	yellow	B65539C1003X001
a	1.81 × 2.7	N22	red	B65539C1002X022
b	1.81 × 3.4	N22	green	B65806C3001X022

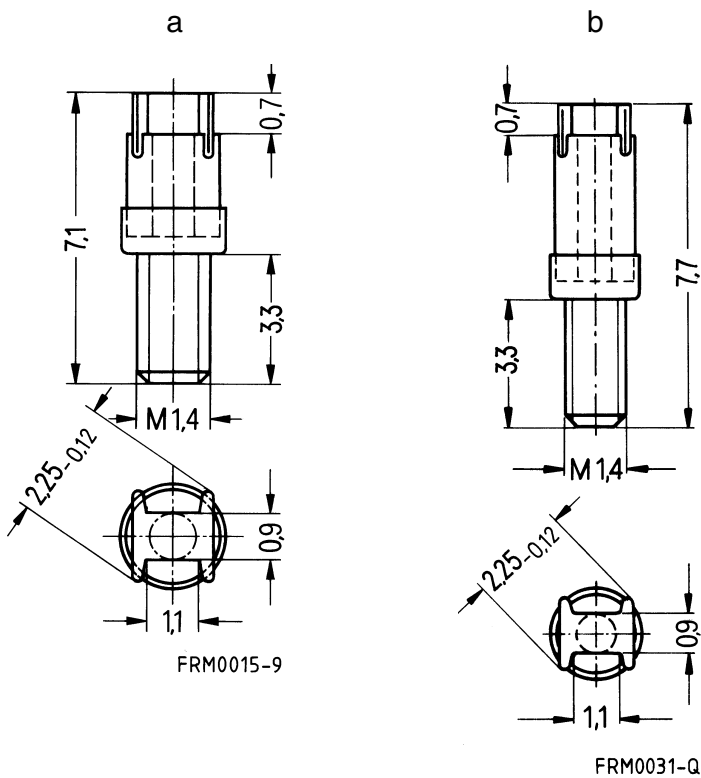

**RM 4 »Low Profile«**
**Core**
**B65803P**

To IEC 62317-4  
 For compact transformers with high inductance  
 Without center hole  
 Delivery mode: sets

**Magnetic characteristics (per set)**

$$\Sigma l/A = 1.2 \text{ mm}^{-1}$$

$$l_e = 17.3 \text{ mm}$$

$$A_e = 14.5 \text{ mm}^2$$

$$A_{\text{min}} = 11.3 \text{ mm}^2$$

$$V_e = 251 \text{ mm}^3$$

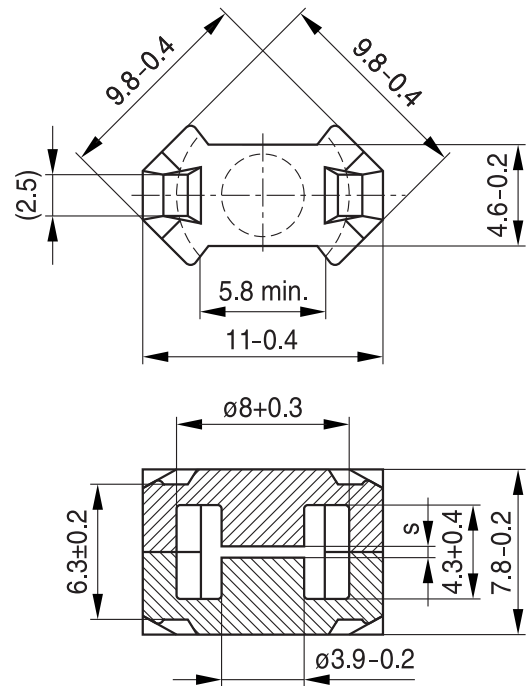
**Approx. weight 1.2 g/set**

FRM0345-E

**Ungapped**

Material	$A_L$ value	$\mu_e$	$P_V$	Ordering code
	nH		W/set	
T38	5000 +40/-30%	4750		B65803P0000Y038
N49	950 +30/-20%	900	< 0.04 ( 50 mT, 500 kHz, 100 °C)	B65803P0000R049
N92	1000 +30/-20%	950	< 0.14 (200 mT, 100 kHz, 100 °C)	B65803P0000R092
N87	1300 +30/-20%	1230	< 0.12 (200 mT, 100 kHz, 100 °C)	B65803P0000R087

### Clamp

With ground terminal, made of stainless spring steel (tinned), 0.3 mm thick,  
 Without ground terminal, made of stainless spring steel, 0.3 mm thick  
 Solderability to IEC 60068-2-20, test Ta, method 1 (aging 3): 235 °C, 2 s  
 Clamping force 40 N per pair of clamps (typical value)  
 Also available as strip clamp on reels on request

### Insulating washer for double-clad PCBs

Made of polycarbonate (UL 94 V-0, insulation class to IEC 60085: E  $\geq$  120 °C), 0.3 mm thick  
 Makrofol FR7-2, [E118859 (M)], natural color, BAYER MATERIALSCIENCE AG

	Ordering code
Clamp with ground terminal (ordering code per piece, 2 are required)	B65804P2203X000
Clamp without ground terminal (ordering code per piece, 2 are required)	B65804P2204X000
Insulating washer (bulk)	B65804C2005X000

### Clamp with ground terminal

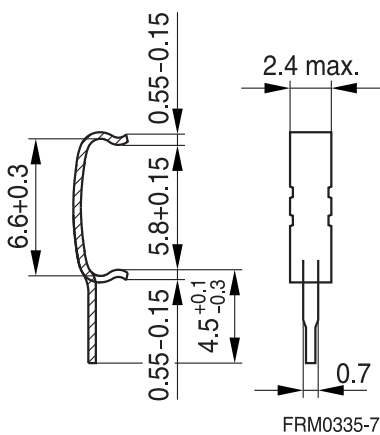

### Clamp without ground terminal

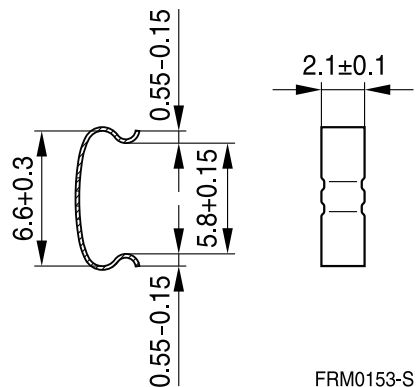

### Insulating washer

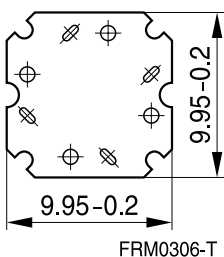



**SMD coil former with J terminals**

Material: GFR liquid crystal polymer (UL 94 V-0, insulation class to IEC 60085:  
 $F \triangleq$  max. operating temperature 155 °C), color code black  
 Vectra C 130 [E83005 (M)], TICONA

Solderability: to IEC 60068-2-58, test Td, method 6 (Group 3): 245 °C, 3 s

Resistance to soldering heat: to IEC 60068-2-58, test Td, method 6 (Group 3): 255 °C, 10 s  
 permissible soldering temperature for wire-wrap connection on coil former: 400 °C, 1 s

Winding: see Data Book 2013, chapter "Processing notes, 2.1"

**Clamp**

Without ground terminal, made of stainless spring steel, 0.3 mm thick

Also available as strip clamp (each carton containing 2 reels)

Sections	$A_N$ mm <sup>2</sup>	$l_N$ mm	$A_R$ value $\mu\Omega$	Terminals <sup>1)</sup>	Ordering code
1	5.0	20.1	138	10	B65804B6010T001
Clamp (ordering code per piece, 2 are required)					B65804P2204X000

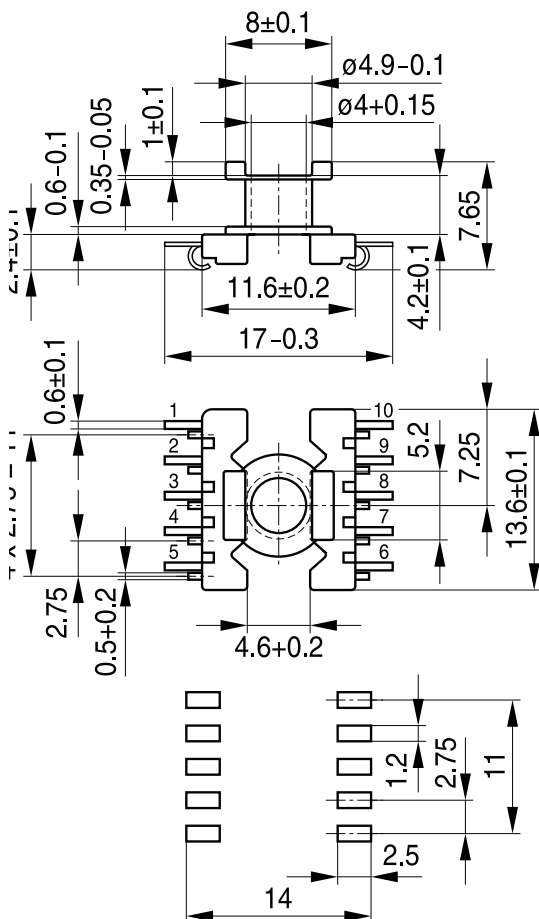
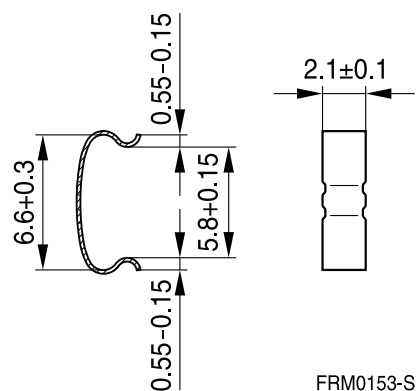
**Coil former**

**Clamp**

Recommended  
PCB layout

FRM0258-5

1) 6 and 8 terminals on request

### **Mechanical stress and mounting**

Ferrite cores have to meet mechanical requirements during assembling and for a growing number of applications. Since ferrites are ceramic materials one has to be aware of the special behavior under mechanical load.

As valid for any ceramic material, ferrite cores are brittle and sensitive to any shock, fast changing or tensile load. Especially high cooling rates under ultrasonic cleaning and high static or cyclic loads can cause cracks or failure of the ferrite cores.

For detailed information see chapter *“Definitions”*, section 8.1.

### **Effects of core combination on $A_L$ value**

Stresses in the core affect not only the mechanical but also the magnetic properties. It is apparent that the initial permeability is dependent on the stress state of the core. The higher the stresses are in the core, the lower is the value for the initial permeability. Thus the embedding medium should have the greatest possible elasticity.

For detailed information see chapter *“Definitions”*, section 8.2.

### **Heating up**

Ferrites can run hot during operation at higher flux densities and higher frequencies.

### **NiZn-materials**

The magnetic properties of NiZn-materials can change irreversible in high magnetic fields.

### **Processing notes**

- The start of the winding process should be soft. Else the flanges may be destroyed.
- To strong winding forces may blast the flanges or squeeze the tube that the cores can no more be mount.
- To long soldering time at high temperature (>300 °C) may effect coplanarity or pin arrangement.
- Not following the processing notes for soldering of the J-leg terminals may cause solderability problems at the transformer because of pollution with Sn oxyd of the tin bath or burned insulation of the wire. For detailed information see chapter *“Processing notes”*, section 8.2.
- The dimensions of the hole arrangement have fixed values and should be understood as a recommendation for drilling the printed circuit board. For dimensioning the pins, the group of holes can only be seen under certain conditions, as they fit into the given hole arrangement. To avoid problems when mounting the transformer, the manufacturing tolerances for positioning the customers' drilling process must be considered by increasing the hole diameter.

**Ferrites and accessories**
**Symbols and terms**

Symbol	Meaning	Unit
A	Cross section of coil	mm <sup>2</sup>
A <sub>e</sub>	Effective magnetic cross section	mm <sup>2</sup>
A <sub>L</sub>	Inductance factor; $A_L = L/N^2$	nH
A <sub>L1</sub>	Minimum inductance at defined high saturation ( $\hat{=} \mu_a$ )	nH
A <sub>min</sub>	Minimum core cross section	mm <sup>2</sup>
A <sub>N</sub>	Winding cross section	mm <sup>2</sup>
A <sub>R</sub>	Resistance factor; $A_R = R_{Cu}/N^2$	$\mu\Omega = 10^{-6} \Omega$
B	RMS value of magnetic flux density	Vs/m <sup>2</sup> , mT
$\Delta B$	Flux density deviation	Vs/m <sup>2</sup> , mT
$\hat{B}$	Peak value of magnetic flux density	Vs/m <sup>2</sup> , mT
$\Delta \hat{B}$	Peak value of flux density deviation	Vs/m <sup>2</sup> , mT
B <sub>DC</sub>	DC magnetic flux density	Vs/m <sup>2</sup> , mT
B <sub>R</sub>	Remanent flux density	Vs/m <sup>2</sup> , mT
B <sub>S</sub>	Saturation magnetization	Vs/m <sup>2</sup> , mT
C <sub>0</sub>	Winding capacitance	F = As/V
CDF	Core distortion factor	mm <sup>-4.5</sup>
DF	Relative disaccommodation coefficient $DF = d/\mu_i$	
d	Disaccommodation coefficient	
E <sub>a</sub>	Activation energy	J
f	Frequency	s <sup>-1</sup> , Hz
f <sub>cutoff</sub>	Cut-off frequency	s <sup>-1</sup> , Hz
f <sub>max</sub>	Upper frequency limit	s <sup>-1</sup> , Hz
f <sub>min</sub>	Lower frequency limit	s <sup>-1</sup> , Hz
f <sub>r</sub>	Resonance frequency	s <sup>-1</sup> , Hz
f <sub>Cu</sub>	Copper filling factor	
g	Air gap	mm
H	RMS value of magnetic field strength	A/m
$\hat{H}$	Peak value of magnetic field strength	A/m
H <sub>DC</sub>	DC field strength	A/m
H <sub>c</sub>	Coercive field strength	A/m
h	Hysteresis coefficient of material	10 <sup>-6</sup> cm/A
h/ $\mu_i^2$	Relative hysteresis coefficient	10 <sup>-6</sup> cm/A
I	RMS value of current	A
I <sub>DC</sub>	Direct current	A
$\hat{I}$	Peak value of current	A
J	Polarization	Vs/m <sup>2</sup>
k	Boltzmann constant	J/K
k <sub>3</sub>	Third harmonic distortion	
k <sub>3c</sub>	Circuit third harmonic distortion	
L	Inductance	H = Vs/A

**Ferrites and accessories**
**Symbols and terms**

Symbol	Meaning	Unit
$\Delta L/L$	Relative inductance change	H
$L_0$	Inductance of coil without core	H
$L_H$	Main inductance	H
$L_p$	Parallel inductance	H
$L_{rev}$	Reversible inductance	H
$L_s$	Series inductance	H
$l_e$	Effective magnetic path length	mm
$l_N$	Average length of turn	mm
$N$	Number of turns	
$P_{Cu}$	Copper (winding) losses	W
$P_{trans}$	Transferrable power	W
$P_V$	Relative core losses	mW/g
PF	Performance factor	
$Q$	Quality factor ( $Q = \omega L/R_s = 1/\tan \delta_L$ )	
$R$	Resistance	$\Omega$
$R_{Cu}$	Copper (winding) resistance ( $f = 0$ )	$\Omega$
$R_h$	Hysteresis loss resistance of a core	$\Omega$
$\Delta R_h$	$R_h$ change	$\Omega$
$R_i$	Internal resistance	$\Omega$
$R_p$	Parallel loss resistance of a core	$\Omega$
$R_s$	Series loss resistance of a core	$\Omega$
$R_{th}$	Thermal resistance	K/W
$R_V$	Effective loss resistance of a core	$\Omega$
$s$	Total air gap	mm
$T$	Temperature	$^{\circ}\text{C}$
$\Delta T$	Temperature difference	K
$T_C$	Curie temperature	$^{\circ}\text{C}$
$t$	Time	s
$t_v$	Pulse duty factor	
$\tan \delta$	Loss factor	
$\tan \delta_L$	Loss factor of coil	
$\tan \delta_r$	(Residual) loss factor at $H \rightarrow 0$	
$\tan \delta_e$	Relative loss factor	
$\tan \delta_h$	Hysteresis loss factor	
$\tan \delta/\mu_i$	Relative loss factor of material at $H \rightarrow 0$	
$U$	RMS value of voltage	V
$\hat{U}$	Peak value of voltage	V
$V_e$	Effective magnetic volume	$\text{mm}^3$
$Z$	Complex impedance	$\Omega$
$Z_n$	Normalized impedance $ Z _n =  Z /N^2 \times \varepsilon (l_e/A_e)$	$\Omega/\text{mm}$

## Ferrites and accessories

### Symbols and terms

Symbol	Meaning	Unit
$\alpha$	Temperature coefficient (TK)	1/K
$\alpha_F$	Relative temperature coefficient of material	1/K
$\alpha_e$	Temperature coefficient of effective permeability	1/K
$\epsilon_r$	Relative permittivity	
$\Phi$	Magnetic flux	Vs
$\eta$	Efficiency of a transformer	
$\eta_B$	Hysteresis material constant	mT <sup>-1</sup>
$\eta_i$	Hysteresis core constant	A <sup>-1</sup> H <sup>-1/2</sup>
$\lambda_s$	Magnetostriction at saturation magnetization	
$\mu$	Relative complex permeability	
$\mu_0$	Magnetic field constant	Vs/Am
$\mu_a$	Relative amplitude permeability	
$\mu_{app}$	Relative apparent permeability	
$\mu_e$	Relative effective permeability	
$\mu_i$	Relative initial permeability	
$\mu_p'$	Relative real (inductive) component of $\bar{\mu}$ (for parallel components)	
$\mu_p''$	Relative imaginary (loss) component of $\bar{\mu}$ (for parallel components)	
$\mu_r$	Relative permeability	
$\mu_{rev}$	Relative reversible permeability	
$\mu_s'$	Relative real (inductive) component of $\bar{\mu}$ (for series components)	
$\mu_s''$	Relative imaginary (loss) component of $\bar{\mu}$ (for series components)	
$\mu_{tot}$	Relative total permeability derived from the static magnetization curve	
$\rho$	Resistivity	$\Omega m^{-1}$
$\Sigma l/A$	Magnetic form factor	mm <sup>-1</sup>
$\tau_{Cu}$	DC time constant $\tau_{Cu} = L/R_{Cu} = A_L/A_R$	s
$\omega$	Angular frequency; $\omega = 2 \pi f$	s <sup>-1</sup>

All dimensions are given in mm.

**SMD** Surface-mount device

## Important notes

The following applies to all products named in this publication:

1. Some parts of this publication contain **statements about the suitability of our products for certain areas of application**. These statements are based on our knowledge of typical requirements that are often placed on our products in the areas of application concerned. We nevertheless expressly point out **that such statements cannot be regarded as binding statements about the suitability of our products for a particular customer application**. As a rule, EPCOS is either unfamiliar with individual customer applications or less familiar with them than the customers themselves. For these reasons, it is always ultimately incumbent on the customer to check and decide whether an EPCOS product with the properties described in the product specification is suitable for use in a particular customer application.
2. We also point out that **in individual cases, a malfunction of electronic components or failure before the end of their usual service life cannot be completely ruled out in the current state of the art, even if they are operated as specified**. In customer applications requiring a very high level of operational safety and especially in customer applications in which the malfunction or failure of an electronic component could endanger human life or health (e.g. in accident prevention or lifesaving systems), it must therefore be ensured by means of suitable design of the customer application or other action taken by the customer (e.g. installation of protective circuitry or redundancy) that no injury or damage is sustained by third parties in the event of malfunction or failure of an electronic component.
3. **The warnings, cautions and product-specific notes must be observed.**
4. In order to satisfy certain technical requirements, **some of the products described in this publication may contain substances subject to restrictions in certain jurisdictions (e.g. because they are classed as hazardous)**. Useful information on this will be found in our Material Data Sheets on the Internet ([www.epcos.com/material](http://www.epcos.com/material)). Should you have any more detailed questions, please contact our sales offices.
5. We constantly strive to improve our products. Consequently, **the products described in this publication may change from time to time**. The same is true of the corresponding product specifications. Please check therefore to what extent product descriptions and specifications contained in this publication are still applicable before or when you place an order. We also **reserve the right to discontinue production and delivery of products**. Consequently, we cannot guarantee that all products named in this publication will always be available. The aforementioned does not apply in the case of individual agreements deviating from the foregoing for customer-specific products.
6. Unless otherwise agreed in individual contracts, **all orders are subject to the current version of the "General Terms of Delivery for Products and Services in the Electrical Industry" published by the German Electrical and Electronics Industry Association (ZVEI)**.
7. The trade names EPCOS, BAOKE, Alu-X, CeraDiode, CeraLink, CSMP, CSSP, CTVS, DeltaCap, DigiSiMic, DSSP, FilterCap, FormFit, MiniBlue, MiniCell, MKD, MKK, MLSC, MotorCap, PCC, PhaseCap, PhaseCube, PhaseMod, PhiCap, SIFERRIT, SIFI, SIKOREL, SilverCap, SIMDAD, SiMic, SIMID, SineFormer, SIOV, SIP5D, SIP5K, ThermoFuse, WindCap are **trademarks registered or pending** in Europe and in other countries. Further information will be found on the Internet at [www.epcos.com/trademarks](http://www.epcos.com/trademarks).



## Стандарт Электрон Связь

Мы молодая и активно развивающаяся компания в области поставок электронных компонентов. Мы поставляем электронные компоненты отечественного и импортного производства напрямую от производителей и с крупнейших складов мира.

Благодаря сотрудничеству с мировыми поставщиками мы осуществляем комплексные и плановые поставки широчайшего спектра электронных компонентов.

Собственная эффективная логистика и склад в обеспечивает надежную поставку продукции в точно указанные сроки по всей России.

Мы осуществляем техническую поддержку нашим клиентам и предпродажную проверку качества продукции. На все поставляемые продукты мы предоставляем гарантию .

Осуществляем поставки продукции под контролем ВП МО РФ на предприятия военно-промышленного комплекса России , а также работаем в рамках 275 ФЗ с открытием отдельных счетов в уполномоченном банке. Система менеджмента качества компании соответствует требованиям ГОСТ ISO 9001.

Минимальные сроки поставки, гибкие цены, неограниченный ассортимент и индивидуальный подход к клиентам являются основой для выстраивания долгосрочного и эффективного сотрудничества с предприятиями радиоэлектронной промышленности, предприятиями ВПК и научно-исследовательскими институтами России.

С нами вы становитесь еще успешнее!

### Наши контакты:

**Телефон:** +7 812 627 14 35

**Электронная почта:** [sales@st-electron.ru](mailto:sales@st-electron.ru)

**Адрес:** 198099, Санкт-Петербург,  
Промышленная ул, дом № 19, литера Н,  
помещение 100-Н Офис 331