



## HD/SD SDI Receiver Complete with SMPTE Video Processing

### Key Features

- Operation at 1.485Gb/s, 1.485/1.001Gb/s and 270Mb/s
- Supports SMPTE 292, SMPTE 259M-C and DVB-ASI
- Integrated Reclocker with low phase noise integrated VCO
- Serial digital reclocked, or non-reclocked output
- Ancillary data extraction
- Parallel data bus selectable as either 20-bit or 10-bit
- Comprehensive error detection and correction features
- Output H, V, F or CEA 861 Timing Signals
- 1.2V digital core power supply, 1.2V and 3.3V analog power supplies, and selectable 1.8V or 3.3V I/O power supply
- GSPI Host Interface
- -20°C to +85°C operating temperature range
- Low power operation (typically 280mW)
- Small 11mm x 11mm 100-ball BGA package
- Pb-free and RoHS compliant

### Errata

Refer to Errata document entitled **GS1660/GS1661 Errata** for this device (document number 53877).

### Applications

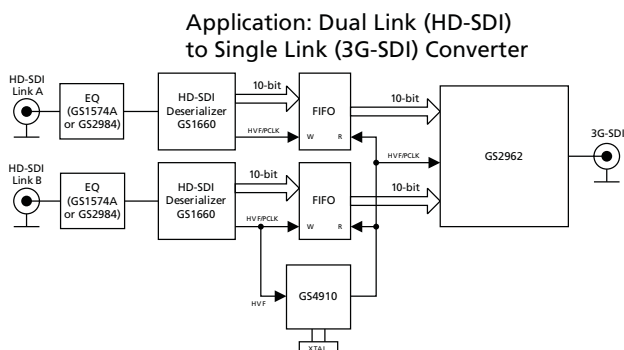

### Description

The GS1660 is a multi-rate SDI Receiver which includes complete SMPTE processing, as per 292M and SMPTE 259M-C. The SMPTE processing features can be bypassed to support signals with other coding schemes.

The device features an integrated Reclocker with an internal VCO and a wide Input Jitter Tolerance (IJT) of 0.7UI.

A serial digital loop through output is provided, which can be configured to output either reclocked or non-reclocked serial digital data. The Serial Digital Output can be connected to an external Cable Driver.

The device operates in one of four basic modes: SMPTE mode, DVB-ASI mode, Data-Through mode or Standby mode.

In SMPTE mode, the GS1660 performs SMPTE de-scrambling and NRZI to NRZ decoding and word alignment. Line-based CRC errors, line number errors, TRS errors and ancillary data check sum errors can all be detected. The GS1660 also provides ancillary data extraction. The entire ancillary data packet is extracted, and written to host-accessible registers. Other processing functions include H:V:F timing extraction, Luma and Chroma ancillary data indication, video standard detection, and SMPTE 352M packet detection and decoding. All of the processing features are optional and may be enabled or disabled via the Host Interface.

In DVB-ASI mode, 8b/10b decoding is applied to the received data stream.

In Data-Through mode, all forms of SMPTE and DVB-ASI decoding are disabled, and the device can be used as a simple serial to parallel converter.

The device can also be placed in a lower power Standby mode. In this mode, no signal processing is carried out and the parallel output is held static.

Parallel data outputs are provided in 20-bit or 10-bit multiplexed format for HD and SD video rates. The associated Parallel Clock input signal operates at 148.5 or

148.5/1.001MHz (HD 10-bit multiplexed modes), 74.25 or 74.25/1.001MHz (for HD 20-bit mode), 27MHz (for SD 10-bit mode) and 13.5MHz (for SD 20-bit mode).

## Functional Block Diagram

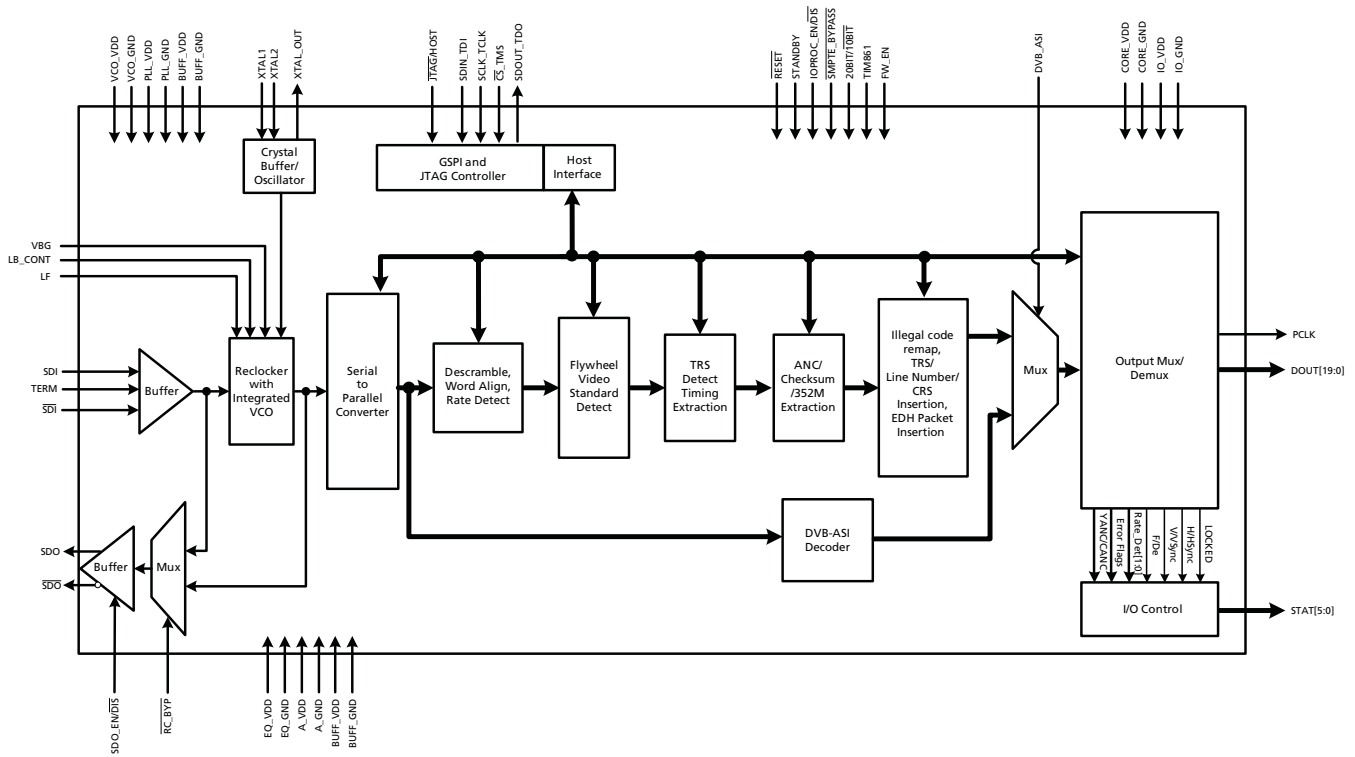

GS1660 Functional Block Diagram

## Revision History

Version	ECR	PCN	Date	Changes and/or Modifications
2	158468	-	September 2012	Changes throughout the document.
1	153472	-	January 2010	Converted to Data Sheet.
0	153079	-	November 2009	New document. Added reference to GS1660/GS1661 Errata (document number 53877).

# Contents

Key Features .....	1
Errata.....	1
Applications.....	1
Description.....	1
Functional Block Diagram .....	2
Revision History .....	2
1. Pin Out.....	7
1.1 Pin Assignment .....	7
1.2 Pin Descriptions .....	7
2. Electrical Characteristics .....	14
2.1 Absolute Maximum Ratings .....	14
2.2 Recommended Operating Conditions .....	14
2.3 DC Electrical Characteristics .....	15
2.4 AC Electrical Characteristics .....	17
3. Input/Output Circuits .....	21
4. Detailed Description.....	24
4.1 Functional Overview .....	24
4.2 Serial Digital Input .....	24
4.3 Serial Digital Loop-Through Output .....	24
4.4 Serial Digital Reclocker .....	25
4.4.1 PLL Loop Bandwidth .....	25
4.5 External Crystal/Reference Clock .....	26
4.6 Lock Detect .....	27
4.6.1 Asynchronous Lock .....	28
4.6.2 Signal Interruption.....	28
4.7 SMPTE Functionality .....	29
4.7.1 Descrambling and Word Alignment .....	29
4.8 Parallel Data Outputs .....	30
4.8.1 Parallel Data Bus Buffers.....	30
4.8.2 Parallel Output in SMPTE Mode .....	32
4.8.3 Output Data Format in DVB-ASI Mode.....	32
4.8.4 Parallel Output in Data-Through Mode .....	33
4.8.5 Parallel Output Clock (PCLK).....	33
4.9 Timing Signal Generator .....	34
4.9.1 Manual Switch Line Lock Handling .....	34
4.9.2 Automatic Switch Line Lock Handling.....	35
4.10 Programmable Multi-function Outputs .....	38
4.11 H:V:F Timing Signal Generation .....	39
4.11.1 CEA-861 Timing Generation .....	40
4.12 Automatic Video Standards Detection .....	47
4.13 Data Format Detection & Indication .....	49
4.14 EDH Detection .....	50
4.14.1 EDH Packet Detection .....	50
4.14.2 EDH Flag Detection .....	50

4.15 Video Signal Error Detection & Indication .....	51
4.15.1 TRS Error Detection .....	52
4.15.2 Line Based CRC Error Detection .....	52
4.15.3 EDH CRC Error Detection.....	53
4.15.4 HD Line Number Error Detection .....	53
4.16 Ancillary Data Detection & Indication .....	53
4.16.1 Programmable Ancillary Data Detection.....	54
4.16.2 SMPTE 352M Payload Identifier .....	55
4.16.3 Ancillary Data Checksum Error .....	55
4.16.4 Video Standard Error .....	56
4.17 Signal Processing .....	56
4.17.1 TRS Correction & Insertion.....	57
4.17.2 Line Based CRC Correction & Insertion .....	58
4.17.3 Line Number Error Correction & Insertion .....	58
4.17.4 ANC Data Checksum Error Correction & Insertion .....	58
4.17.5 EDH CRC Correction & Insertion .....	58
4.17.6 Illegal Word Re-mapping .....	58
4.17.7 TRS and Ancillary Data Preamble Remapping.....	59
4.17.8 Ancillary Data Extraction.....	59
4.18 GSPI - HOST Interface .....	63
4.18.1 Command Word Description .....	63
4.18.2 Data Read or Write Access.....	64
4.18.3 4GSPI Timing .....	65
4.19 Host Interface Register Maps .....	67
4.20 JTAG Test Operation .....	75
4.21 Device Power-up .....	76
4.22 Device Reset .....	76
4.23 Standby Mode .....	76
5. Application Reference Design .....	77
5.1 Typical Application Circuit .....	77
6. References & Relevant Standards .....	78
7. Package & Ordering Information .....	79
7.1 Package Dimensions .....	79
7.2 Packaging Data .....	80
7.3 Marking Diagram .....	80
7.4 Solder Reflow Profiles .....	81
7.5 Ordering Information .....	81

# List of Figures

Figure 3-1: Digital Input Pin with Schmitt Trigger .....	21
Figure 3-2: Bidirectional Digital Input/Output Pin.....	21
Figure 3-3: Bidirectional Digital Input/Output Pin with programmable drive strength.....	22
Figure 3-4: XTAL1/XTAL2/XTAL-OUT .....	22
Figure 3-5: VBG .....	22
Figure 3-6: LB_CONT .....	23
Figure 3-7: Loop Filter .....	23
Figure 3-8: SDI/ $\overline{\text{SDI}}$ and TERM .....	23
Figure 3-9: SDO/ $\overline{\text{SDO}}$ .....	23
Figure 4-1: 27MHz Clock Sources .....	27
Figure 4-2: PCLK to Data and Control Signal Output Timing - SDR Mode 1 .....	30
Figure 4-3: PCLK to Data and Control Signal Output Timing - SDR Mode 2 .....	31
Figure 4-4: Switch Line Locking on a Non-Standard Switch Line .....	35
Figure 4-5: H:V:F Output Timing - HDTV 20-bit Mode .....	39
Figure 4-6: H:V:F Output Timing - HDTV 10-bit Mode .....	39
Figure 4-7: H:V:F Output Timing - HD 20-bit Output Mode .....	39
Figure 4-8: H:V:F Output Timing - HD 10-bit Output Mode .....	40
Figure 4-9: H:V:F Output Timing - SD 20-bit Output Mode .....	40
Figure 4-10: H:V:F Output Timing - SD 10-bit Output Mode .....	40
Figure 4-11: H:V:DE Output Timing 1280 x 720p @ 59.94/60 (Format 4) .....	41
Figure 4-12: H:V:DE Output Timing 1920 x 1080i @ 59.94/60 (Format 5) .....	42
Figure 4-13: H:V:DE Output Timing 720 (1440) x 480i @ 59.94/60 (Format 6&7) .....	43
Figure 4-14: H:V:DE Output Timing 1280 x 720p @ 50 (Format 19) .....	43
Figure 4-15: H:V:DE Output Timing 1920 x 1080i @ 50 (Format 20) .....	44
Figure 4-16: H:V:DE Output Timing 720 (1440) x 576 @ 50 (Format 21 & 22) .....	45
Figure 4-17: H:V:DE Output Timing 1920 x 1080p @ 23.94/24 (Format 32) .....	45
Figure 4-18: H:V:DE Output Timing 1920 x 1080p @ 25 (Format 33) .....	46
Figure 4-19: H:V:DE Output Timing 1920 x 1080p @ 29.97/30 (Format 34) .....	46
Figure 4-20: Y/1ANC and C/2ANC Signal Timing .....	54
Figure 4-21: Ancillary Data Extraction - Step A .....	60
Figure 4-22: Ancillary Data Extraction - Step B .....	61
Figure 4-23: Ancillary Data Extraction - Step C .....	62
Figure 4-24: Ancillary Data Extraction - Step D .....	62
Figure 4-25: GSPI Application Interface Connection .....	63
Figure 4-26: Command Word Format .....	64
Figure 4-27: Data Word Format .....	65
Figure 4-28: Write Mode .....	65
Figure 4-29: Read Mode .....	65
Figure 4-30: GSPI Time Delay .....	65
Figure 4-31: In-Circuit JTAG .....	75
Figure 4-32: System JTAG .....	76
Figure 4-33: Reset Pulse .....	76
Figure 7-1: Pb-free Solder Reflow Profile .....	81

## List of Tables

Table 1-1: Pin Descriptions .....	7
Table 2-1: Absolute Maximum Ratings.....	14
Table 2-2: Recommended Operating Conditions.....	14
Table 2-3: DC Electrical Characteristics .....	15
Table 2-4: AC Electrical Characteristics .....	17
Table 4-1: Serial Digital Output.....	25
Table 4-2: PLL Loop Bandwidth .....	26
Table 4-3: Input Clock Requirements.....	27
Table 4-4: Lock Detect Conditions.....	28
Table 4-5: GS1660 Output Video Data Format Selections.....	31
Table 4-6: GS1660 PCLK Output Rates .....	33
Table 4-7: Switch Line Position for Digital Systems .....	36
Table 4-8: Output Signals Available on Programmable Multi-Function Pins .....	38
Table 4-9: Supported CEA-861 Formats .....	40
Table 4-10: Supported Video Standard Codes .....	47
Table 4-11: Data Format Register Codes .....	49
Table 4-12: Error Status Register and Error Mask Register .....	52
Table 4-13: IOPROC_DISABLE Register Bits .....	57
Table 4-14: GSPI Time Delay.....	65
Table 4-15: GSPI Timing Parameters (50% levels; 3.3V or 1.8V operation) .....	66
Table 4-16: Configuration and Status Registers.....	67
Table 4-17: ANC Extraction FIFO Access Registers.....	75
Table 7-1: Packaging Data.....	80

# 1. Pin Out

## 1.1 Pin Assignment

	1	2	3	4	5	6	7	8	9	10
A	VBG	LF	LB_CONT	VCO_VDD	STAT0	STAT1	IO_VDD	PCLK	DOUT18	DOUT17
B	A_VDD	PLL_VDD	RSV	VCO_GND	STAT2	STAT3	IO_GND	DOUT19	DOUT16	DOUT15
C	SDI	A_GND	PLL_VDD	PLL_VDD	STAT4	STAT5	$\overline{\text{RESET}}_{\text{TRST}}$	DOUT12	DOUT14	DOUT13
D	$\overline{\text{SDI}}$	A_GND	A_GND	PLL_GND	CORE_GND	CORE_VDD	FW_EN/DIS	JTAG/HOST	IO_GND	IO_VDD
E	SDI_VDD	SDI_GND	A_GND	PLL_GND	CORE_GND	CORE_VDD	SDOUT_TDO	SDIN_TDI	DOUT10	DOUT11
F	TERM	RSV	A_GND	PLL_GND	CORE_GND	CORE_VDD	$\overline{\text{CS}}_{\text{TMS}}$	SCLK_TCK	DOUT8	DOUT9
G	RSV	RSV	$\overline{\text{RC\_BYP}}$	CORE_GND	CORE_GND	CORE_VDD	$\overline{\text{SMPTE\_BYPASS}}$	DVB_ASI	IO_GND	IO_VDD
H	BUFF_VDD	BUFF_GND	RSV	RSV	TIM_861	XTAL_OUT	20bit/10bit	IOPROC_EN/DIS	DOUT6	DOUT7
J	SDO	$\overline{\text{SDO\_EN/DIS}}$	RSV	RSV	RSV	XTAL2	IO_GND	DOUT1	DOUT4	DOUT5
K	$\overline{\text{SDO}}$	STANDBY	RSV	RSV	RSV	XTAL1	IO_VDD	DOUT0	DOUT2	DOUT3

## 1.2 Pin Descriptions

Table 1-1: Pin Descriptions

Pin Number	Name	Timing	Type	Description
A1	VBG		Analog Input	Band Gap voltage filter connection.
A2	LF		Analog Input	Loop Filter component connection.
A3	LB_CONT		Analog Input	Connection for loop bandwidth control resistor.
A4	VCO_VDD		Input Power	POWER pin for the VCO. Connect to 1.2V±5% analog supply followed by a RC filter (see 5.1 Typical Application Circuit). A 105Ω 1% resistor must be used in the RC filter circuit. VCO_VDD is nominally 0.7V.

**Table 1-1: Pin Descriptions (Continued)**

Pin Number	Name	Timing	Type	Description																								
A5, A6, B5, B6, C5, C6	STAT[0:5]		Output	<p>MULTI-FUNCTIONAL OUTPUT PORT.</p> <p>Please refer to the Output Logic parameters in the <a href="#">DC Electrical Characteristics</a> table for logic level threshold and compatibility.</p> <p>Each of the STAT [0:5] pins can be configured individually to output one of the following signals:</p> <table border="1"> <thead> <tr> <th>Signal</th> <th>Default</th> </tr> </thead> <tbody> <tr> <td>H/HSYNC</td> <td>STAT0</td> </tr> <tr> <td>V/VSYNC</td> <td>STAT1</td> </tr> <tr> <td>F/DE</td> <td>STAT2</td> </tr> <tr> <td>LOCKED</td> <td>STAT3</td> </tr> <tr> <td>Y/1ANC</td> <td>STAT4</td> </tr> <tr> <td>C/2ANC</td> <td>–</td> </tr> <tr> <td><u>DATA ERROR</u></td> <td>STAT5</td> </tr> <tr> <td><u>VIDEO ERROR</u></td> <td>–</td> </tr> <tr> <td>EDH DETECTED</td> <td>–</td> </tr> <tr> <td>CARRIER DETECT</td> <td>–</td> </tr> <tr> <td>RATE_DET</td> <td>–</td> </tr> </tbody> </table>	Signal	Default	H/HSYNC	STAT0	V/VSYNC	STAT1	F/DE	STAT2	LOCKED	STAT3	Y/1ANC	STAT4	C/2ANC	–	<u>DATA ERROR</u>	STAT5	<u>VIDEO ERROR</u>	–	EDH DETECTED	–	CARRIER DETECT	–	RATE_DET	–
Signal	Default																											
H/HSYNC	STAT0																											
V/VSYNC	STAT1																											
F/DE	STAT2																											
LOCKED	STAT3																											
Y/1ANC	STAT4																											
C/2ANC	–																											
<u>DATA ERROR</u>	STAT5																											
<u>VIDEO ERROR</u>	–																											
EDH DETECTED	–																											
CARRIER DETECT	–																											
RATE_DET	–																											
A7, D10, G10, K7	IO_VDD		Input Power	POWER connection for digital I/O. Connect to 3.3V or 1.8V DC digital.																								
A8	PCLK		Output	<p>PARALLEL DATA BUS CLOCK</p> <p>Please refer to the Output Logic parameters in the <a href="#">DC Electrical Characteristics</a> table for logic level threshold and compatibility.</p> <table border="1"> <tbody> <tr> <td>HD 10-bit mode</td> <td>PCLK @ 148.5 or 148.5/1.001MHz</td> </tr> <tr> <td>HD 20-bit mode</td> <td>PCLK @ 74.25 or 74.25/1.001MHz</td> </tr> <tr> <td>SD 10-bit mode</td> <td>PCLK @ 27MHz</td> </tr> <tr> <td>SD 20-bit mode</td> <td>PCLK @ 13.5MHz</td> </tr> </tbody> </table>	HD 10-bit mode	PCLK @ 148.5 or 148.5/1.001MHz	HD 20-bit mode	PCLK @ 74.25 or 74.25/1.001MHz	SD 10-bit mode	PCLK @ 27MHz	SD 20-bit mode	PCLK @ 13.5MHz																
HD 10-bit mode	PCLK @ 148.5 or 148.5/1.001MHz																											
HD 20-bit mode	PCLK @ 74.25 or 74.25/1.001MHz																											
SD 10-bit mode	PCLK @ 27MHz																											
SD 20-bit mode	PCLK @ 13.5MHz																											
A9, A10, B8, B9, B10, C8, C9, C10, E9, E10	DOUT18, 17, 19, 16, 15, 12, 14, 13, 10, 11		Output	<p>PARALLEL DATA BUS</p> <p>Please refer to the Output Logic parameters in the <a href="#">DC Electrical Characteristics</a> table for logic level threshold and compatibility.</p> <table border="1"> <tbody> <tr> <td>20-bit mode 20bit/10bit = HIGH</td> <td> <p>SMPTE mode (<math>\overline{\text{SMPTE\_BYPASS}}</math> = HIGH and DVB_ASI = LOW): Luma data output for SD and HD data rates.</p> <p>DVB-ASI mode (<math>\overline{\text{SMPTE\_BYPASS}}</math> = LOW and DVB_ASI = HIGH): Not defined</p> <p>Data-Through mode (<math>\overline{\text{SMPTE\_BYPASS}}</math> = LOW and DVB_ASI = LOW): Data output</p> </td> </tr> <tr> <td>10-bit mode 20bit/10bit = LOW</td> <td> <p>SMPTE mode (<math>\overline{\text{SMPTE\_BYPASS}}</math> = HIGH and DVB_ASI = LOW): Multiplexed Luma/Chroma data output for SD and HD data rates.</p> <p>DVB-ASI mode (<math>\overline{\text{SMPTE\_BYPASS}}</math> = LOW and DVB_ASI = HIGH): 8b/10b decoded DVB-ASI data</p> <p>Data-Through mode (<math>\overline{\text{SMPTE\_BYPASS}}</math> = LOW and DVB_ASI = LOW): Data output</p> </td> </tr> </tbody> </table>	20-bit mode 20bit/10bit = HIGH	<p>SMPTE mode (<math>\overline{\text{SMPTE\_BYPASS}}</math> = HIGH and DVB_ASI = LOW): Luma data output for SD and HD data rates.</p> <p>DVB-ASI mode (<math>\overline{\text{SMPTE\_BYPASS}}</math> = LOW and DVB_ASI = HIGH): Not defined</p> <p>Data-Through mode (<math>\overline{\text{SMPTE\_BYPASS}}</math> = LOW and DVB_ASI = LOW): Data output</p>	10-bit mode 20bit/10bit = LOW	<p>SMPTE mode (<math>\overline{\text{SMPTE\_BYPASS}}</math> = HIGH and DVB_ASI = LOW): Multiplexed Luma/Chroma data output for SD and HD data rates.</p> <p>DVB-ASI mode (<math>\overline{\text{SMPTE\_BYPASS}}</math> = LOW and DVB_ASI = HIGH): 8b/10b decoded DVB-ASI data</p> <p>Data-Through mode (<math>\overline{\text{SMPTE\_BYPASS}}</math> = LOW and DVB_ASI = LOW): Data output</p>																				
20-bit mode 20bit/10bit = HIGH	<p>SMPTE mode (<math>\overline{\text{SMPTE\_BYPASS}}</math> = HIGH and DVB_ASI = LOW): Luma data output for SD and HD data rates.</p> <p>DVB-ASI mode (<math>\overline{\text{SMPTE\_BYPASS}}</math> = LOW and DVB_ASI = HIGH): Not defined</p> <p>Data-Through mode (<math>\overline{\text{SMPTE\_BYPASS}}</math> = LOW and DVB_ASI = LOW): Data output</p>																											
10-bit mode 20bit/10bit = LOW	<p>SMPTE mode (<math>\overline{\text{SMPTE\_BYPASS}}</math> = HIGH and DVB_ASI = LOW): Multiplexed Luma/Chroma data output for SD and HD data rates.</p> <p>DVB-ASI mode (<math>\overline{\text{SMPTE\_BYPASS}}</math> = LOW and DVB_ASI = HIGH): 8b/10b decoded DVB-ASI data</p> <p>Data-Through mode (<math>\overline{\text{SMPTE\_BYPASS}}</math> = LOW and DVB_ASI = LOW): Data output</p>																											



**Table 1-1: Pin Descriptions (Continued)**

Pin Number	Name	Timing	Type	Description
B1	A_VDD		Input Power	POWER pin for analog circuitry. Connect to 3.3V DC analog.
B2, C3, C4	PLL_VDD		Input Power	POWER pins for the Reclocker PLL. Connect to 1.2V DC analog.
B3, F2, G1, G2	RSV			These pins must be left unconnected.
B4	VCO_GND		Input Power	GND pin for the VCO. Connect to analog GND.
B7, D9, G9, J7	IO_GND		Input Power	GND connection for digital I/O. Connect to digital GND.
C1, D1	SDI, $\overline{\text{SDI}}$		Analog Input	Serial Digital Differential Input.
C2, D2, D3, E3, F3	A_GND		Input Power	GND pins for sensitive analog circuitry. Connect to analog GND.
C7	$\overline{\text{RESET\_TRST}}$		Input	<p>CONTROL SIGNAL INPUT</p> <p>Please refer to the Input Logic parameters in the <a href="#">DC Electrical Characteristics</a> table for logic level threshold and compatibility.</p> <p>Used to reset the internal operating conditions to default settings and to reset the JTAG sequence.</p> <p>Normal mode (JTAG/<math>\overline{\text{HOST}}</math> = LOW):</p> <p>When LOW, all functional blocks are set to default conditions and all digital output signals become high impedance.</p> <p>When HIGH, normal operation of the device resumes.</p> <p>JTAG test mode (JTAG/<math>\overline{\text{HOST}}</math> = HIGH):</p> <p>When LOW, all functional blocks are set to default and the JTAG test sequence is reset.</p> <p>When HIGH, normal operation of the JTAG test sequence resumes after <math>\overline{\text{RESET\_TRST}}</math> is de-asserted.</p>
D4, E4, F4	PLL_GND		Input Power	GND pins for the Reclocker PLL. Connect to analog GND.
D5, E5, F5, G4, G5	CORE_GND		Input Power	GND connection for device core. Connect to digital GND.
D6, E6, F6, G6	CORE_VDD		Input Power	POWER connection for device core. Connect to 1.2V DC digital.
D7	SW_EN		Input	<p>CONTROL SIGNAL INPUT</p> <p>Signal levels are LVCMOS/LVTTL compatible.</p> <p>Used to enable switch-line locking, as described in <a href="#">Section 4.9.1</a>.</p>
D8	JTAG/ $\overline{\text{HOST}}$		Input	<p>CONTROL SIGNAL INPUT</p> <p>Please refer to the Input Logic parameters in the <a href="#">DC Electrical Characteristics</a> table for logic level threshold and compatibility.</p> <p>Used to select JTAG test mode or host interface mode.</p> <p>When JTAG/<math>\overline{\text{HOST}}</math> is HIGH, the host interface port is configured for JTAG test.</p> <p>When JTAG/<math>\overline{\text{HOST}}</math> is LOW, normal operation of the host interface port resumes.</p>
E1	SDI_VDD		Input Power	POWER pin for SDI buffer. Connect to 3.3V DC analog.
E2	SDI_GND		Input Power	GND pin for SDI buffer. Connect to analog GND.

**Table 1-1: Pin Descriptions (Continued)**

Pin Number	Name	Timing	Type	Description
E7	SDOUT_TDO		Output	<p>COMMUNICATION SIGNAL OUTPUT</p> <p>Please refer to the Output Logic parameters in the <a href="#">DC Electrical Characteristics</a> table for logic level threshold and compatibility.</p> <p>GSPI serial data output/test data out.</p> <p>In JTAG mode (<math>JTAG/\overline{HOST}</math> = HIGH), this pin is used to shift test results from the device.</p> <p>In host interface mode, this pin is used to read status and configuration data from the device.</p> <p><b>Note:</b> GSPI is slightly different than the SPI. For more details on GSPI, please refer to <a href="#">4.18 GSPI - HOST Interface</a>.</p>
E8	SDIN_TDI		Input	<p>COMMUNICATION SIGNAL INPUT</p> <p>Please refer to the Input Logic parameters in the <a href="#">DC Electrical Characteristics</a> table for logic level threshold and compatibility.</p> <p>GSPI serial data in/test data in.</p> <p>In JTAG mode (<math>JTAG/\overline{HOST}</math> = HIGH), this pin is used to shift test data into the device.</p> <p>In host interface mode, this pin is used to write address and configuration data words into the device.</p>
F1	TERM		Analog Input	Decoupling for internal SDI termination resistors.
F7	$\overline{CS}$ _TMS		Input	<p>COMMUNICATION SIGNAL INPUT</p> <p>Please refer to the Input Logic parameters in the <a href="#">DC Electrical Characteristics</a> table for logic level threshold and compatibility.</p> <p>Chip select / test mode start.</p> <p>In JTAG mode (<math>JTAG/\overline{HOST}</math> = HIGH), this pin is Test Mode Start, used to control the operation of the JTAG test.</p> <p>In host interface mode (<math>JTAG/\overline{HOST}</math> = LOW), this pin operates as the host interface chip select and is active LOW.</p>
F8	SCLK_TCK		Input	<p>COMMUNICATION SIGNAL INPUT</p> <p>Please refer to the Input Logic parameters in the <a href="#">DC Electrical Characteristics</a> table for logic level threshold and compatibility.</p> <p>Serial data clock signal.</p> <p>In JTAG mode (<math>JTAG/\overline{HOST}</math> = HIGH), this pin is the JTAG clock.</p> <p>In host interface mode (<math>JTAG/\overline{HOST}</math> = LOW), this pin is the host interface serial bit clock.</p> <p>All JTAG/host interface addresses and data are shifted into/out of the device synchronously with this clock.</p>

**Table 1-1: Pin Descriptions (Continued)**

Pin Number	Name	Timing	Type	Description
F9, F10, H9, H10, J8, J9, J10, K8, K9, K10	DOUT8, 9, 6, 7, 1, 4, 5, 0, 2, 3		Output	<p>PARALLEL DATA BUS</p> <p>Please refer to the Output Logic parameters in the <a href="#">DC Electrical Characteristics</a> table for logic level threshold and compatibility.</p> <hr/> <p>20-bit mode 20bit/10bit = HIGH</p> <p>SMPTE mode (<math>\overline{\text{SMPTE\_BYPASS}} = \text{HIGH}</math> and <math>\text{DVB\_ASI} = \text{LOW}</math>): Chroma data output for SD and HD data rates.</p> <p>DVB-ASI mode (<math>\overline{\text{SMPTE\_BYPASS}} = \text{LOW}</math> and <math>\text{DVB\_ASI} = \text{HIGH}</math>): Not defined</p> <p>Data-Through mode (<math>\overline{\text{SMPTE\_BYPASS}} = \text{LOW}</math> and <math>\text{DVB\_ASI} = \text{LOW}</math>): Data output</p> <hr/> <p>10-bit mode 20bit/10bit = LOW</p> <p>Forced LOW</p>
G3	$\overline{\text{RC\_BYP}}$		Input	<p>CONTROL SIGNAL INPUT</p> <p>Please refer to the Input Logic parameters in the <a href="#">DC Electrical Characteristics</a> table for logic level threshold and compatibility.</p> <p>When this pin is LOW, the serial digital output is the buffered version of the input serial data. When this pin is HIGH, the serial digital output is the reclocked version of the input serial data.</p>
G7	$\overline{\text{SMPTE\_BYPASS}}$		Input/Output	<p>CONTROL SIGNAL INPUT/OUTPUT</p> <p>Please refer to the Input/Output Logic parameters in the <a href="#">DC Electrical Characteristics</a> table for logic level threshold and compatibility.</p> <p>Indicates the presence of valid SMPTE data.</p> <p>When the <math>\text{AUTO}/\overline{\text{MAN}}</math> bit in the host interface register is HIGH (Default), this pin is an OUTPUT. <math>\overline{\text{SMPTE\_BYPASS}}</math> is HIGH when the device locks to a SMPTE compliant input. <math>\overline{\text{SMPTE\_BYPASS}}</math> is LOW under all other conditions.</p> <p>When the <math>\text{AUTO}/\overline{\text{MAN}}</math> bit in the host interface register is LOW, this pin is an INPUT:</p> <p>No SMPTE scrambling takes place, and none of the I/O processing features of the device are available when <math>\overline{\text{SMPTE\_BYPASS}}</math> is set LOW.</p> <p>When <math>\overline{\text{SMPTE\_BYPASS}}</math> is set HIGH, the device carries out SMPTE scrambling and I/O processing.</p> <p>When <math>\overline{\text{SMPTE\_BYPASS}}</math> and <math>\text{DVB\_ASI}</math> are both set LOW, the device operates in Data-Through mode.</p>

**Table 1-1: Pin Descriptions (Continued)**

Pin Number	Name	Timing	Type	Description
G8	DVB_ASI		Input/Output	<p>CONTROL SIGNAL INPUT</p> <p>Please refer to the Input/Output Logic parameters in the <a href="#">DC Electrical Characteristics</a> table for logic level threshold and compatibility.</p> <p>Used to enable/disable DVB-ASI data extraction in manual mode.</p> <p>When the <math>\overline{\text{AUTO/MAN}}</math> bit in the host interface is LOW, this pin is an input and when the DVB_ASI pin is set HIGH the device carries out DVB_ASI data extraction and processing. The <math>\overline{\text{SMPTE\_BYPASS}}</math> pin must be set LOW. When <math>\overline{\text{SMPTE\_BYPASS}}</math> and DVB_ASI are both set LOW, the device operates in Data-Through mode.</p> <p>When the <math>\overline{\text{AUTO/MAN}}</math> bit in the host interface is HIGH (Default), DVB-ASI is configured as a status output (set LOW), and DVB-ASI input streams are not supported or recognized.</p>
H1	BUFF_VDD		Input Power	POWER pin for the serial digital output 50Ω buffer. Connect to 3.3V DC analog.
H2	BUFF_GND		Input Power	GND pin for the cable driver buffer. Connect to analog GND.
H3, H4, J3, J4, J5, K3, K5	RSV			These pins must be connected to CORE_GND.
H5	TIM_861		Input	<p>CONTROL SIGNAL INPUT</p> <p>Please refer to the Input Logic parameters in the <a href="#">DC Electrical Characteristics</a> table for logic level threshold and compatibility.</p> <p>Used to select CEA-861 timing mode.</p> <p>When TIM_861 is HIGH, the device outputs CEA 861 timing signals (HSYNC/VSYNC/DE) instead of H:V:F digital timing signals.</p>
H6	XTAL_OUT		Digital Output	Buffered 27MHz crystal output. Can be used to cascade the crystal signal.
H7	20bit/ $\overline{10\text{bit}}$		Input	<p>CONTROL SIGNAL INPUT</p> <p>Please refer to the Input Logic parameters in the <a href="#">DC Electrical Characteristics</a> table for logic level threshold and compatibility.</p> <p>Used to select the output bus width.</p> <p>HIGH = 20-bit, LOW = 10-bit.</p>
H8	IOPROC_EN/ $\overline{\text{DIS}}$		Input	<p>CONTROL SIGNAL INPUT</p> <p>Please refer to the Input Logic parameters in the <a href="#">DC Electrical Characteristics</a> table for logic level threshold and compatibility.</p> <p>Used to enable or disable video processing features. When IOPROC_EN is HIGH, the video processing features of the device are enabled. When IOPROC_EN is LOW, the processing features of the device are disabled, and the device is in a low-latency operating mode.</p>
J1, K1	SDO, $\overline{\text{SDO}}$		Output	<p>Serial Data Output Signal.</p> <p>50Ω CML buffer for interfacing to an external cable driver.</p> <p>Serial digital output signal operating at 1.485Gb/s, 1.485/1.001Gb/s and 270Mb/s.</p>

**Table 1-1: Pin Descriptions (Continued)**

Pin Number	Name	Timing	Type	Description
J2	SDO_EN/ $\overline{\text{DIS}}$		Input	<p>CONTROL SIGNAL INPUT</p> <p>Please refer to the Input Logic parameters in the <a href="#">DC Electrical Characteristics</a> table for logic level threshold and compatibility.</p> <p>Used to enable/disable the serial digital output stage.</p> <p>When SDO_EN/<math>\overline{\text{DIS}}</math> is LOW, the serial digital output signals, SDO and <math>\overline{\text{SDO}}</math>, are both pulled HIGH.</p> <p>When SDO_EN/<math>\overline{\text{DIS}}</math> is HIGH, the serial digital output signals, SDO and <math>\overline{\text{SDO}}</math>, are enabled.</p>
J6, K6	XTAL2, XTAL1		Analog Input	Input connection for 27MHz crystal.
K2	STANDBY		Input	<p>CONTROL SIGNAL INPUT</p> <p>Please refer to the Input Logic parameters in the <a href="#">DC Electrical Characteristics</a> table for logic level threshold and compatibility.</p> <p>When this pin is set HIGH, the device is placed in a power-saving mode. No data processing occurs, and the digital I/Os are powered down.</p> <p>In this mode, the serial digital output signals, SDO and <math>\overline{\text{SDO}}</math>, are both pulled HIGH.</p>
K4	RSV			This pin must be left unconnected.

## 2. Electrical Characteristics

### 2.1 Absolute Maximum Ratings

Table 2-1: Absolute Maximum Ratings

Parameter	Value/Units
Supply Voltage, Digital Core (CORE_VDD)	-0.3V to +1.5V
Supply Voltage, Digital I/O (IO_VDD)	-0.3V to +4.0V
Supply Voltage, Analog 1.2V (PD_VDD, VCO_VDD)	-0.3V to +1.5V
Supply Voltage, Analog 3.3V (SDI_VDD, BUFF_VDD, A_VDD)	-0.3V to +4.0V
Input Voltage Range (digital inputs)	-2.0V to +5.25V
Ambient Operating Temperature (T <sub>A</sub> )	-40°C ≤ T <sub>A</sub> ≤ 95°C
Storage Temperature (T <sub>STG</sub> )	-40°C ≤ T <sub>STG</sub> ≤ 125°C
Peak Reflow Temperature (JEDEC J-STD-020C)	260°C
ESD Sensitivity, HBM (JESD22-A114)	2kV

NOTES:

Absolute Maximum Ratings are those values beyond which damage may occur. Functional operation under these conditions or at any other condition beyond those indicated in the AC/DC Electrical Characteristics sections is not implied.

### 2.2 Recommended Operating Conditions

Table 2-2: Recommended Operating Conditions

Parameter	Symbol	Conditions	Min	Typ	Max	Units	Notes
Operating Temperature Range, Ambient	T <sub>A</sub>	–	-20	–	85	°C	–
Supply Voltage, Digital Core	CORE_VDD	–	1.14	1.2	1.26	V	–
Supply Voltage, Digital I/O	IO_VDD	1.8V mode	1.71	1.8	1.89	V	–
		3.3V mode	3.13	3.3	3.47	V	–
Supply Voltage, PLL	PLL_VDD	–	1.14	1.2	1.26	V	–
Supply Voltage, VCO	VCO_VDD	–	–	0.7	–	V	1
Supply Voltage, Analog	A_VDD	–	3.13	3.3	3.47	V	2
Supply Voltage, Serial Digital Input	SDI_VDD	–	3.13	3.3	3.47	V	2
Supply Voltage, CD Buffer	BUFF_VDD	–	3.13	3.3	3.47	V	2

NOTES

1. This is 0.7V rather than 1.2V because there is a voltage drop across an external 105Ω resistor. See [Typical Application Circuit on page 77](#).
2. The 3.3V supplies must track the 3.3V supply of an external EQ and external CD.

## 2.3 DC Electrical Characteristics

**Table 2-3: DC Electrical Characteristics**

Guaranteed over recommended operating conditions unless otherwise noted.

Parameter	Symbol	Conditions	Min	Typ	Max	Units	Notes
<b>System</b>							
+1.2V Supply Current	$I_{1V2}$	10/20bit HD	–	160	210	mA	–
		10/20bit SD	–	135	165	mA	–
		DVB_ASI	–	135	165	mA	–
+1.8V Supply Current	$I_{1V8}$	10/20bit HD	–	20	21	mA	–
		10/20bit SD	–	6	7	mA	–
		DVB_ASI	–	6	7	mA	–
+3.3V Supply Current	$I_{3V3}$	10/20bit HD	–	65	75	mA	–
		10/20bit SD	–	35	45	mA	–
		DVB_ASI	–	35	45	mA	–
Total Device Power (IO_VDD = 1.8V)	$P_{1D8}$	10/20bit HD	–	280	335	mW	–
		10/20bit SD	–	240	305	mW	–
		DVB_ASI	–	240	305	mW	–
		Reset	–	200	–	mW	–
		Standby	–	16	44	mW	–
Total Device Power (IO_VDD = 3.3V)	$P_{3D3}$	10/20bit HD	–	400	505	mW	–
		10/20bit SD	–	280	370	mW	–
		DVB_ASI	–	280	370	mW	–
		Reset	–	220	–	mW	–
		Standby	–	16	44	mW	–
<b>Digital I/O</b>							
Input Logic LOW	$V_{IL}$	3.3V or 1.8V operation	IO_VSS -0.3	–	0.3 x IO_VDD	V	–
Input Logic HIGH	$V_{IH}$	3.3V or 1.8V operation	0.7 x IO_VDD	–	IO_VDD +0.3	V	–
Output Logic LOW	$V_{OL}$	IOL = 5mA, 1.8V operation	–	–	0.2	V	–
		IOL = 8mA, 3.3V operation	–	–	0.4	V	–
Output Logic HIGH	$V_{OH}$	IOH = 5mA, 1.8V operation	1.4	–	–	V	–
		IOH = 8mA, 3.3V operation	2.4	–	–	V	–
<b>Serial Input</b>							
Serial Input Common Mode Voltage	–	50Ω load	2.5	SDI_VDD -(0.75/2)	SDI_VDD -(0.55/2)	V	–

**Table 2-3: DC Electrical Characteristics (Continued)**

Guaranteed over recommended operating conditions unless otherwise noted.

Parameter	Symbol	Conditions	Min	Typ	Max	Units	Notes
<b>Serial Output</b>							
Serial Output Common Mode Voltage	–	50Ω load	BUFF_VDD -(0.6/2)	BUFF_VDD -(0.45/2)	BUFF_VDD -(0.35/2)	V	–

**Notes:**

1. The output drive strength of the digital outputs can be programmed through the host interface. Please see [Table 4-16: Configuration and Status Registers](#), register 06Dh for details.



## 2.4 AC Electrical Characteristics

**Table 2-4: AC Electrical Characteristics**

Guaranteed over recommended operating conditions unless otherwise noted.

Parameter	Symbol	Conditions	Min	Typ	Max	Units	Notes			
<b>System</b>										
Device Latency: SMPTE mode, IOPROC_EN = 1	-	HD	44	-	48	PCLK	-			
		SD	46	-	53	PCLK	-			
Device Latency: SMPTE mode, IOPROC_EN = 0	-	HD	33	-	36	PCLK	-			
		SD	32	-	35	PCLK	-			
Device Latency: SMPTE bypass, IOPROC_EN = 0	-	HD	6	-	9	PCLK	-			
		SD	5	-	9	PCLK	-			
Device Latency: DVB-ASI	-	SD	12	-	16	PCLK	-			
Reset Pulse Width	$t_{reset}$	-	1	-	-	ms	-			
<b>Parallel Output</b>										
Parallel Clock Frequency	$f_{PCLK}$	-	13.5	-	148.5	MHz	-			
Parallel Clock Duty Cycle	$DC_{PCLK}$	-	45	-	55	%	-			
Output Data Hold Time (1.8V)	$t_{oh}$	HD 10-bit 6pF Load	DBUS	1.0	-	-	ns	1		
			STAT	1.0	-	-	ns	1		
		HD 20-bit 6pF Load	DBUS	1.0	-	-	ns	1		
			STAT	1.0	-	-	ns	1		
		SD 10-bit 6pF Load	DBUS	19.4	-	-	ns	1		
			STAT	19.4	-	-	ns	1		
		SD 20-bit 6pF Load	DBUS	38.0	-	-	ns	1		
			STAT	38.0	-	-	ns	1		
		Output Data Hold Time (3.3V)	$t_{oh}$	HD 10-bit 6pF Load	DBUS	1.0	-	-	ns	2
					STAT	1.0	-	-	ns	2
				HD 20-bit 6pF Load	DBUS	1.0	-	-	ns	2
					STAT	1.0	-	-	ns	2
SD 10-bit 6pF Load	DBUS			19.4	-	-	ns	2		
	STAT			19.4	-	-	ns	2		
SD 20-bit 6pF Load	DBUS			38.0	-	-	ns	2		
	STAT			38.0	-	-	ns	2		

**Table 2-4: AC Electrical Characteristics (Continued)**

Guaranteed over recommended operating conditions unless otherwise noted.

Parameter	Symbol	Conditions	Min	Typ	Max	Units	Notes			
Output Data Delay Time (1.8V)	$t_{od}$	HD 10-bit 15pF Load	DBUS	–	–	3.7	ns	3		
			STAT	–	–	4.4	ns	3		
		HD 20-bit 15pF Load	DBUS	–	–	3.7	ns	3		
			STAT	–	–	4.4	ns	3		
		SD 10-bit 15pF Load	DBUS	–	–	22.2	ns	3		
			STAT	–	–	22.2	ns	3		
		SD 20-bit 15pF Load	DBUS	–	–	41.0	ns	3		
			STAT	–	–	41.0	ns	3		
		Output Data Delay Time (3.3V)	$t_{od}$	HD 10-bit 15pF Load	DBUS	–	–	3.7	ns	4
					STAT	–	–	4.1	ns	4
HD 20-bit 15pF Load	DBUS			–	–	3.7	ns	4		
	STAT			–	–	4.1	ns	4		
SD 10-bit 15pF Load	DBUS			–	–	22.2	ns	4		
	STAT			–	–	22.2	ns	4		
SD 20-bit 15pF Load	DBUS			–	–	41.0	ns	4		
	STAT			–	–	41.0	ns	4		
Output Data Rise/Fall Time (1.8V)	$t_r/t_f$			All modes 6pF Load	STAT	–	–	0.4	ns	1
					DBUS	–	–	0.4	ns	1
		All modes 15pF Load	STAT	–	–	1.5	ns	3		
			DBUS	–	–	1.4	ns	3		
		Output Data Rise/Fall Time (3.3V)	$t_r/t_f$	All modes 6pF Load	STAT	–	–	0.5	ns	2
					DBUS	–	–	0.4	ns	2
All modes 15pF Load	STAT			–	–	1.6	ns	4		
	DBUS			–	–	1.4	ns	4		
<b>Serial Digital Input</b>										
Serial Input Data Rate	$DR_{SDI}$	–	0.27	–	1.485	Gb/s	–			
Serial Input Swing	$\Delta V_{SDI}$	Differential with 100 $\Omega$ load	500	800	1100	mVp-p	–			
Serial Input Jitter Tolerance	IJT	Nominal loop bandwidth	Square wave mod.	0.7	0.8	–	UI	–		
<b>Serial Digital Output</b>										
Serial Output Data Rate	$DR_{SDO}$	–	0.27	–	1.485	Gb/s	–			

**Table 2-4: AC Electrical Characteristics (Continued)**

Guaranteed over recommended operating conditions unless otherwise noted.

Parameter	Symbol	Conditions	Min	Typ	Max	Units	Notes
Serial Output Swing	$\Delta V_{SDO}$	Differential with 100 $\Omega$ load	350	–	600	mVp-p	–
Serial Output Rise Time 20% ~ 80%	$t_{rSDO}$	–	–	–	180	ps	–
Serial Output Fall Time 20% ~ 80%	$t_{fSDO}$	–	–	–	180	ps	–
Serial Output Intrinsic Jitter	$t_{OJ}$	SMPTE colour bar HD signal	–	–	100	ps	–
		SMPTE colour bar SD signal	–	–	400	ps	–
Serial Output Duty Cycle Distortion	$DCD_{SDD}$	HD	–	10	–	ps	–
		SD	–	20	–	ps	–
Synchronous lock time	–	–	–	–	25	$\mu$ s	6
Asynchronous lock time	–	–	100	–	825	$\mu$ s	–
Lock time from power-up	–	After 20 minutes at -20°C	–	325	–	ms	–
<b>GSPI</b>							
GSPI Input Clock Frequency	$f_{SCLK}$	–	–	–	60	MHz	5
GSPI Input Clock Duty Cycle	$DC_{SCLK}$	50% levels 3.3V or 1.8V operation	40	50	60	%	5
GSPI Input Data Setup Time	–	–	1.5	–	–	ns	5
GSPI Input Data Hold Time	–	–	1.5	–	–	ns	5
GSPI Output Data Hold Time	–	–	1.5	–	–	ns	5
$\overline{CS}$ low before SCLK rising edge	–	50% levels 3.3V or 1.8V operation	1.5	–	–	ns	5
Time between end of command word (or data in Auto-Increment mode) and the first SCLK of the following data word - write cycle	–	50% levels 3.3V or 1.8V operation	37.1	–	–	ns	5
Time between end of command word (or data in Auto-Increment mode) and the first SCLK of the following data word - read cycle	–	50% levels 3.3V or 1.8V operation	148.4	–	–	ns	5

**Table 2-4: AC Electrical Characteristics (Continued)**

Guaranteed over recommended operating conditions unless otherwise noted.

Parameter	Symbol	Conditions	Min	Typ	Max	Units	Notes
$\overline{CS}$ high after SCLK falling edge	–	50% levels 3.3V or 1.8V operation	37.1	–	–	ns	5

**Notes:**

1. 1.89V and 0°C.
2. 3.47V and 0°C.
3. 1.71V and 85°C
4. 3.13V and 85°C
5. Timing parameters defined in [Section 4.18.3](#)

### 3. Input/Output Circuits

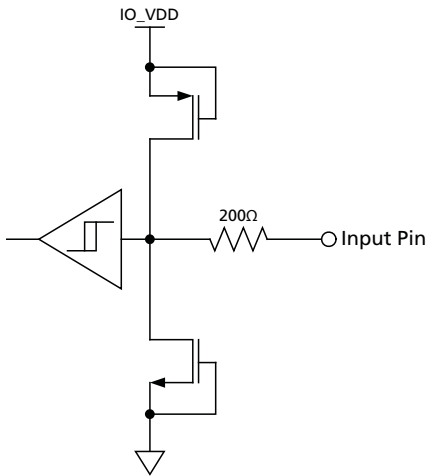

Figure 3-1: Digital Input Pin with Schmitt Trigger (20BIT/10BIT,  $\overline{CS\_TMS}$ , SW\_EN, IOPROC\_EN/ $\overline{DIS}$ , JTAG/HOST, RC\_BYP,  $\overline{RESET\_TRST}$ , SCLK\_TCK, SDIN\_TDI, SDO\_EN/ $\overline{DIS}$ , STANDBY, TIM\_861)

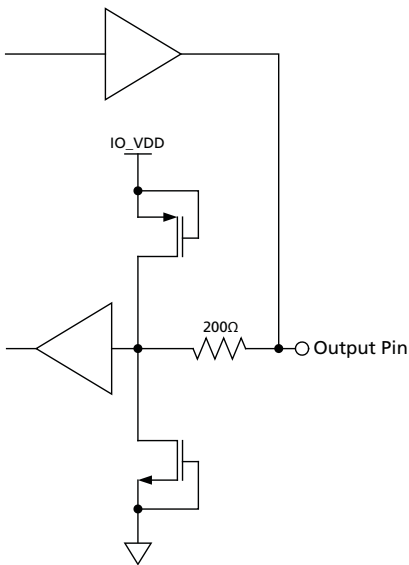

Figure 3-2: Bidirectional Digital Input/Output Pin - Configured to Output unless in Reset Mode. (DVB\_ASI,  $\overline{SMPTE\_BYPASS}$ )

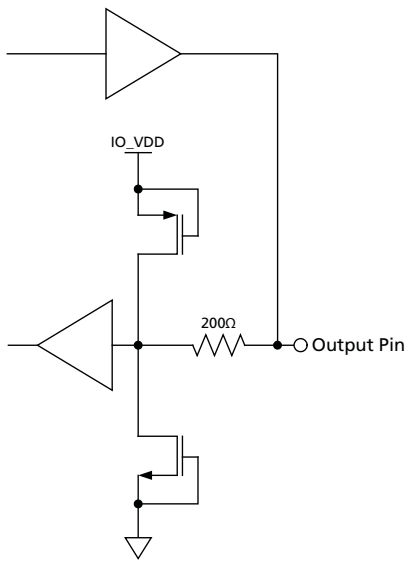

Figure 3-3: Bidirectional Digital Input/Output Pin with programmable drive strength. These pins are configured to output unless in Reset Mode; in which case they are high-impedance. The drive strength can be set by writing to address 06Dh in the host interface register. (DOUT0, DOUT1, DOUT2, DOUT3, DOUT4, DOUT5, DOUT6, DOUT7, DOUT8, DOUT9, SDOUT\_TDO, STAT0, STAT1, STAT2, STAT3, STAT4, STAT5, XTAL\_OUT, DOUT10, DOUT11, DOUT12, DOUT13, DOUT14, DOUT15, DOUT16, DOUT17, DOUT18, DOUT19, PCLK)

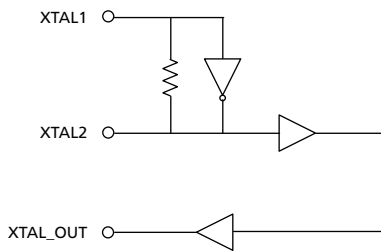

Figure 3-4: XTAL1/XTAL2/XTAL-OUT

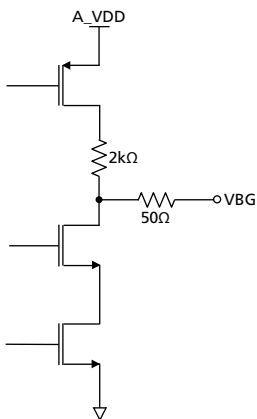

Figure 3-5: VBG

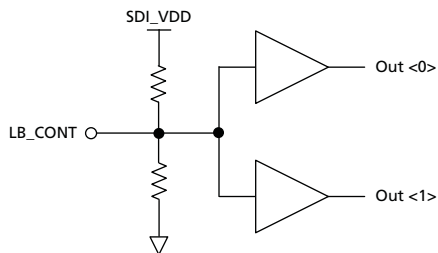

Figure 3-6: LB\_CONT

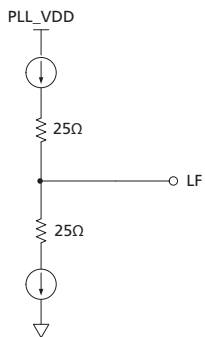

Figure 3-7: Loop Filter

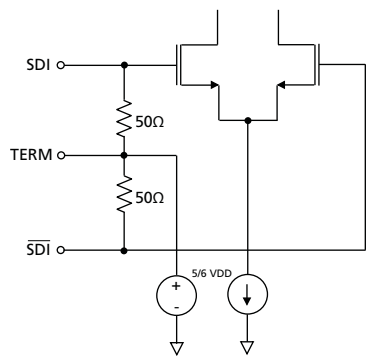

Figure 3-8: SDI/ $\overline{\text{SDI}}$  and TERM

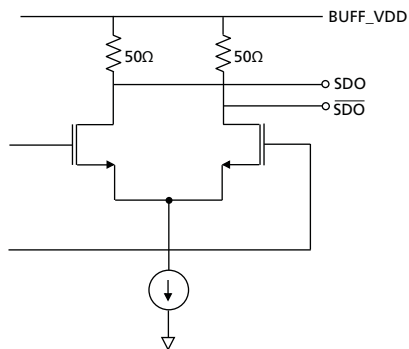

Figure 3-9: SDO/ $\overline{\text{SDO}}$

## 4. Detailed Description

Refer to the document entitled **GS1660/GS1661 Errata** for this device (document number 53877).

### 4.1 Functional Overview

The GS1660 is a multi-rate, multi-standard receiver with integrated SMPTE video processing, compliant with SMPTE 292 and SMPTE 259M-C signals. When used in conjunction with Gennum's HD/SD-capable equalizers, a complete receive solution that supports full bandwidth 1080p video at 1.485Gb/s can be realized.

The GS1660 includes an integrated reclocker, serial data loop through output, robust serial-to-parallel conversion, integrated SMPTE video processing, and additional processing functions such as ancillary data extraction, EDH support, and DVB-ASI decoding.

The device supports four distinct modes of operation that can be set through external device pins or by programming internal registers through the host interface; SMPTE mode, Data-Through mode, DVB-ASI mode and Standby mode.

In SMPTE mode, all video processing features are enabled by default.

In DVB-ASI mode, the GS1660 carries out 8b/10b decoding and generates 10-bit parallel DVB-ASI compliant data.

In Data-Through mode, the device operates as a simple serial to parallel converter. No additional processing features are enabled.

Standby mode is the low power consumption mode of the device. In this mode, the internal reclocker unlocks, and the internal configuration registers are not accessible through the host interface.

The GS1660 includes a JTAG interface for boundary scan testing.

### 4.2 Serial Digital Input

The GS1660 can accept serial digital inputs compliant with SMPTE 292 and SMPTE 259M-C. The serial digital input buffer features 50 $\Omega$  input termination and can be DC-coupled to Gennum's HD/SD-capable equalizers.

### 4.3 Serial Digital Loop-Through Output

The GS1660 contains a 100 $\Omega$  differential serial output buffer which can be configured to output either a retimed or a buffered version of the serial digital input. The  $\overline{\text{SDO}}$  and  $\overline{\text{SDO}}$  outputs of this buffer can interface directly to a 1.485Gb/s-capable, SMPTE compliant Gennum cable driver. See [5.1 Typical Application Circuit](#) on [page 77](#).

When the  $\overline{\text{RC\_BYP}}$  pin is set HIGH, the serial digital output is the re-timed version of the serial input.



When the  $\overline{\text{RC\_BYP}}$  pin is set LOW, the serial digital output is simply the buffered version of the serial input, bypassing the internal reclocker.

The output can be disabled by setting the  $\text{SDO\_EN}/\overline{\text{DIS}}$  pin LOW. The output is also disabled when the STANDBY pin is asserted HIGH. When the output is disabled, both SDO and  $\overline{\text{SDO}}$  pins are set to VDD and remain static.

The SDO output is muted when the  $\overline{\text{RC\_BYP}}$  pin is set HIGH and the PLL is unlocked (LOCKED pin is LOW). When muted, the output is held static at logic '0' or logic '1'.

**Table 4-1: Serial Digital Output**

$\text{SDO\_EN}/\overline{\text{DIS}}$	$\overline{\text{RC\_BYP}}$	$\text{SDO}/\overline{\text{SDO}}$
0	X	Disabled
1	1	Re-timed
1	0	Buffered (not re-timed)

NOTE: The serial digital output is muted when the GS1660 is unlocked.

## 4.4 Serial Digital Reclocker

The GS1660 includes both a PLL stage and a sampling stage.

The PLL is comprised of two distinct loops:

- A coarse frequency acquisition loop sets the centre frequency of the integrated Voltage Controlled Oscillator (VCO) using an external 27MHz reference clock
- A fine frequency and phase locked loop aligns the VCO's phase and frequency to the input serial digital stream

The frequency lock loop results in a very fast lock time.

The sampling stage re-times the serial digital input with the locked VCO clock. This generates a clean serial digital stream, which may be output on the  $\text{SDO}/\overline{\text{SDO}}$  output pins and converted to parallel data for further processing. Parallel data is not affected by  $\overline{\text{RC\_BYP}}$ . Only the SDO is affected by this pin.

### 4.4.1 PLL Loop Bandwidth

The fine frequency and phase lock loop in the GS1660 reclocker is non-linear. The PLL loop bandwidth scales with the jitter amplitude of the input data stream; automatically reduces bandwidth in response to higher jitter. This allows the PLL to reject more of the jitter in the input data stream and produce a very clean reclocked output.

The loop bandwidth of the GS1660 PLL is defined with 0.2UI input jitter. The bandwidth is controlled by the LB\_CONT pin. Under nominal conditions, with the LB\_CONT pin floating and 0.2UI input jitter applied, the loop bandwidth is set to 1/1000 of the frequency of the input data stream. Connecting the LB\_CONT pin to 3.3V reduces the bandwidth to half of the nominal setting. Connecting the LB\_CONT pin to GND increases the bandwidth to double the nominal setting. [Table 4-2](#) below summarizes this information.

**Table 4-2: PLL Loop Bandwidth**

Input Data Rate	LB_CONT Pin Connection	Loop Bandwidth (MHz) <sup>1</sup>
SD	3.3V	0.135
	Floating	0.27
	0V	0.54
HD	3.3V	0.75
	Floating	1.5
	0V	3.0

<sup>1</sup>Measured with 0.2UI input jitter applied

## 4.5 External Crystal/Reference Clock

The GS1660 requires an external 27MHz reference clock for correct operation. This reference clock is generated by connecting a crystal to the XTAL1 and XTAL2 pins of the device. See [Application Reference Design on page 77](#). [Table 4-3](#) shows XTAL characteristics.

Alternately, a 27MHz external clock source can be connected to the XTAL1 pin of the device, as shown in [Figure 4-1](#).

The frequency variation of the crystal including aging, supply and temperature variation should be less than +/-100ppm.

The equivalent series resistance (or motional resistance) should be a maximum of 50Ω.

The external crystal is used in the frequency acquisition process. It has no impact on the output jitter performance of the part when the part is locked to incoming data. Because of this, the only key parameter is the frequency variation of the crystal that is stated above.

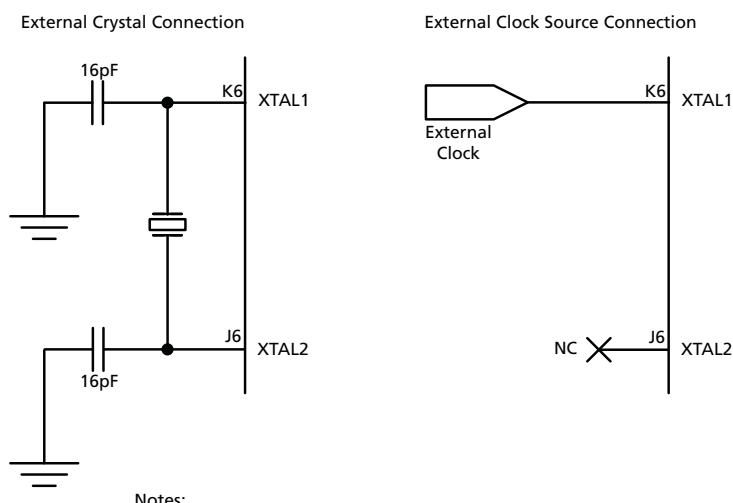

- Notes:
1. Capacitor values listed represent the total capacitance, including discrete capacitance and parasitic board capacitance.
  2. XTAL1 serves as an input, which may alternatively accept a 27MHz clock source.

Figure 4-1: 27MHz Clock Sources

Table 4-3: Input Clock Requirements

Parameter	Min	Typ	Max	UOM	Notes
XTAL1 Low Level Input Voltage ( $V_{il}$ )	–	–	20% of VDD_IO	V	3
XTAL1 High Level Input Voltage ( $V_{ih}$ )	80% of VDDIO	–	–	V	3
XTAL1 Input Slew Rate	2	–	–	V/ns	3
XTAL1 to XOUT Prop. Delay (High to Low)	1.3	1.5	2.3	ns	3
XTAL1 to XOUT Prop. Delay (Low to High)	1.3	1.6	2.3	ns	3

NOTES:

Valid when the cell is used to buffer an external clock source which is connected to the XTAL1 pin, then nothing should be connected to the XTAL2 pin.

## 4.6 Lock Detect

The LOCKED output signal is available by default on the STAT3 output pin, but may be programmed to be output through any one of the six programmable multi-functional pins of the device; STAT[5:0].

The LOCKED output signal is set HIGH by the Lock Detect block under the following conditions:

**Table 4-4: Lock Detect Conditions**

Mode of Operation	Mode Setting	Condition for Locked
Data-Through Mode	$\overline{\text{SMPTE\_BYPASS}} = \text{LOW}$ $\text{DVB\_ASI} = \text{LOW}$	Reclocker PLL is locked.
SMPTE Mode	$\overline{\text{SMPTE\_BYPASS}} = \text{HIGH}$ $\text{DVB\_ASI} = \text{LOW}$	Reclocker PLL is locked 2 consecutive TRS words are detected in a 2-line window.
DVB_ASI Mode	$\overline{\text{SMPTE\_BYPASS}} = \text{LOW}$ $\text{DVB\_ASI} = \text{HIGH}$ Bit $\overline{\text{AUTO/MAN}} = \text{LOW}$	Reclocker PLL is locked 32 consecutive DVB_ASI words with no errors are detected within a 128-word window.

**NOTE 1:** The part will lock into ASI in Auto mode, but could falsely unlock for some ASI input patterns.

**NOTE 2:** In Standby mode, the reclocker PLL unlocks. However, the LOCKED signal retains whatever state it previously held. So, if before Standby assertion, the LOCKED signal is HIGH, then during standby, it remains HIGH regardless of the status of the PLL.

### 4.6.1 Asynchronous Lock

The lock detection algorithm is a continuous process, beginning at device power-up or after a system reset. It continues until the device is powered down or held in reset.

The device first determines if a valid serial digital input signal has been presented to the device. If no valid serial data stream has been detected, the serial data into the device is considered invalid, and the LOCKED signal is LOW.

Once a valid input signal has been detected, the asynchronous lock algorithm enters a “hunt” phase, in which the device attempts to detect the presence of either TRS words or DVB-ASI sync words.

By default, the device powers up in auto mode (the  $\overline{\text{AUTO/MAN}}$  bit in the host interface is set HIGH). In this mode, the device operating frequency toggles between HD and SD rates as it attempts to lock to the incoming data rate. The PCLK output continues to operate, and the frequency may switch between 148.5MHz, 74.25MHz, 27MHz and 13.5MHz.

When the device is operating in manual mode ( $\overline{\text{AUTO/MAN}}$  bit in the host interface is LOW), the operating frequency needs to be set through the host interface using the RATE\_DET bit. In this mode, the asynchronous lock algorithm does not toggle the operating rate of the device and attempts to lock within a single standard. Lock is achieved within three lines of the selected standard.

### 4.6.2 Signal Interruption

The device tolerates a signal interruption of up to 10µs without unlocking, as long as no TRS words are deleted by this interruption. If a signal interruption of greater than 10µs is detected, the lock detection algorithm may lose the current data rate, and LOCKED will de-assert until the data rate is re-acquired by the lock detection block.

## 4.7 SMPTE Functionality

### 4.7.1 Descrambling and Word Alignment

The GS1660 performs NRZI to NRZ decoding and data descrambling according to SMPTE SMPTE 292/SMPTE 259M-C and word aligns the data to TRS sync words.

When operating in Manual mode (AUTO/ $\overline{\text{MAN}}$  bit in the host interface is set LOW), the device only carries out SMPTE decoding, descrambling and word alignment when the SMPTE\_BYPASS pin is set HIGH and the DVB\_ASI pin is set LOW.

When operating in Auto mode (AUTO/ $\overline{\text{MAN}}$  bit in the host interface is set HIGH), the GS1660 carries out descrambling and word alignment to enable the detection of TRS sync words. When two consecutive valid TRS words (SAV and EAV), with the same bit alignment have been detected, the device word-aligns the data to the TRS ID words.

TRS ID word detection is a continuous process. The device remains in SMPTE mode until TRS ID words fail to be detected.

**NOTE:** Both 8-bit and 10-bit TRS headers are identified by the device.

## 4.8 Parallel Data Outputs

The parallel data outputs are aligned to the rising edge of the PCLK.

### 4.8.1 Parallel Data Bus Buffers

The parallel data bus, status signal outputs and control signal input pins are all connected to high-impedance buffers.

The device supports 1.8 or 3.3V (LVTTTL and LVCMOS levels) supplied at the IO\_VDD and IO\_GND pins.

All output buffers (including the PCLK output), are set to high-impedance in Reset mode ( $\overline{\text{RESET\_TRST}} = \text{LOW}$ ).

#### I/O Timing Specs:

##### 10-bit SDR Mode:

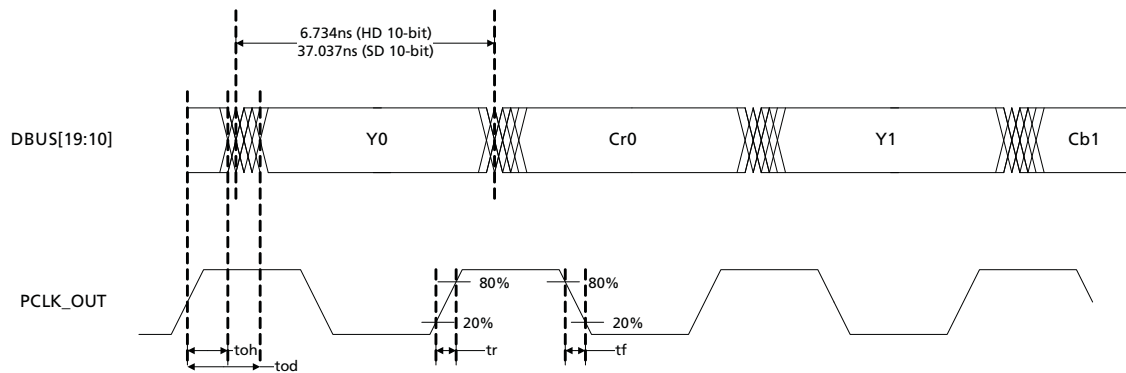

		10bHD Mode											
		3.3V			1.8V								
		toh	tr/tf (min)	Cload	tod	tr/tf (max)	Cload	toh	tr/tf (min)	Cload	tod	tr/tf (max)	Cload
dbus		1.000ns	0.400ns	6 pF	3.700ns	1.400ns	15 pF	1.000ns	0.400ns	6 pF	3.700ns	1.400ns	15 pF
stat		1.000ns	0.500ns		4.100ns	1.600ns		1.000ns	0.400ns		4.400ns	1.500ns	

  

		10bSD Mode											
		3.3V			1.8V								
		toh	tr/tf (min)	Cload	tod	tr/tf (max)	Cload	toh	tr/tf (min)	Cload	tod	tr/tf (max)	Cload
dbus		19.400ns	0.400ns	6 pF	22.200ns	1.400ns	15 pF	19.400ns	0.400ns	6 pF	22.200ns	1.400ns	15 pF
stat		19.400ns	0.500ns		22.200ns	1.600ns		19.400ns	0.400ns		22.200ns	1.500ns	

Figure 4-2: PCLK to Data and Control Signal Output Timing - SDR Mode 1

I/O Timing Specs:

20-bit SDR Mode:

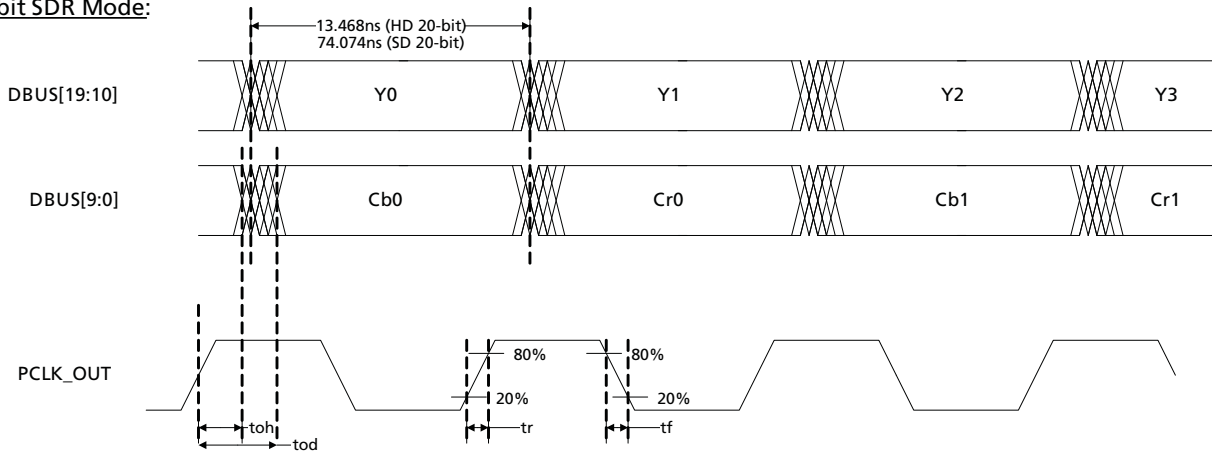

20bHD Mode												
3.3V						1.8V						
	toh	tr/tf (min)	Cload	tod	tr/tf (max)	Cload	toh	tr/tf (min)	Cload	tod	tr/tf (max)	Cload
dbus	1.000ns	0.400ns	6 pF	3.700ns	1.400ns	15 pF	1.000ns	0.400ns	6 pF	3.700ns	1.400ns	15 pF
stat	1.000ns	0.500ns		4.100ns	1.600ns		1.000ns	0.400ns		4.400ns	1.500ns	

20bSD Mode												
3.3V						1.8V						
	toh	tr/tf (min)	Cload	tod	tr/tf (max)	Cload	toh	tr/tf (min)	Cload	tod	tr/tf (max)	Cload
dbus	38.000ns	0.400ns	6 pF	41.000ns	1.400ns	15 pF	38.000ns	0.400ns	6 pF	41.000ns	1.400ns	15 pF
stat	38.000ns	0.500ns		41.000ns	1.600ns		38.000ns	0.400ns		41.000ns	1.500ns	

Figure 4-3: PCLK to Data and Control Signal Output Timing - SDR Mode 2

The GS1660 has a 20-bit output parallel bus, which can be configured for different output formats as shown in Table 4-5.

Table 4-5: GS1660 Output Video Data Format Selections

Output Data Format	Pin/Register Bit Settings				DOUT[9:0]	DOUT[19:10]
	20BIT /10BIT	RATE_SEL	SMPTE_BYPASS	DVB-ASI		
20-bit demultiplexed HD format	HIGH	LOW	HIGH	LOW	Chroma	Luma
20-bit data output HD format	HIGH	LOW	LOW	LOW	DATA	DATA
20-bit demultiplexed SD format	HIGH	HIGH	HIGH	LOW	Chroma	Luma
20-bit data output SD format	HIGH	HIGH	LOW	LOW	DATA	DATA

**Table 4-5: GS1660 Output Video Data Format Selections (Continued)**

Output Data Format	Pin/Register Bit Settings				DOUT[9:0]	DOUT[19:10]
	$\overline{20BIT/10BIT}$	RATE_SEL	$\overline{SMPTE\_BYPASS}$	DVB-ASI		
10-bit multiplexed HD format	LOW	LOW	HIGH	LOW	Driven LOW	Luma/Chroma
10-bit data output HD format	LOW	LOW	LOW	LOW	Driven LOW	DATA
10-bit multiplexed SD format	LOW	HIGH	HIGH	LOW	Driven LOW	Luma/Chroma
10-bit data output SD format	LOW	HIGH	LOW	LOW	Driven LOW	DATA
DVB-ASI format	LOW	HIGH	–	HIGH	DOUT19 = WORD_ERR DOUT18 = SYNC_OUT DOUT17 = H_OUT DOUT16 = G_OUT DOUT15 = F_OUT DOUT14 = E_OUT DOUT13 = D_OUT DOUT12 = C_OUT DOUT11 = B_OUT DOUT10 = A_OUT	

NOTE: When in Auto Mode, swap RATE\_SEL with RATE\_DET.

### 4.8.2 Parallel Output in SMPTE Mode

When the device is operating in SMPTE mode ( $\overline{SMPTE\_BYPASS}$  = HIGH and DVB\_ASI = LOW), data is output in either Multiplexed or Demultiplexed form depending on the setting of the  $\overline{20bit/10bit}$  pin.

When operating in 20-bit mode ( $\overline{20bit/10bit}$  = HIGH), the output data is demultiplexed Luma and Chroma data for SD and HD data rates.

When operating in 10-bit mode ( $\overline{20bit/10bit}$  = LOW), the output data is multiplexed Luma and Chroma data for SD and HD data rates. In this mode, the data is presented on the DOUT[19:10] pins, with DOUT[9:0] being forced LOW.

### 4.8.3 Output Data Format in DVB-ASI Mode

In DVB-ASI mode, the  $\overline{20bit/10bit}$  pin must be set LOW to configure the output parallel bus for 10-bit operation.

DVB-ASI mode is enabled when the  $\overline{AUTO/MAN}$  bit is LOW,  $\overline{SMPTE\_BYPASS}$  pin is LOW and the DVB\_ASI pin is HIGH.

The extracted 8-bit data is presented on DOUT[17:10] such that DOUT[17:10] = HOUT ~ AOUT, where AOUT is the least significant bit of the decoded transport stream data.

In addition, the DOUT19 and DOUT18 pins are configured as DVB-ASI status signals WORDERR and SYNCOUT respectively.

SYNCOUT is HIGH whenever a K28.5 sync character is output from the device.



WORDERR is HIGH whenever the device has detected a running disparity error or illegal code word.

#### 4.8.4 Parallel Output in Data-Through Mode

This mode is enabled when the  $\overline{\text{SMPTE\_BYPASS}}$  and  $\overline{\text{DVB\_ASI}}$  pins are LOW.

In this mode, data is passed to the output bus without any decoding, descrambling or word-alignment.

The output data width (10-bit or 20-bit) is controlled by the setting of the  $\overline{20\text{bit}/10\text{bit}}$  pin.

#### 4.8.5 Parallel Output Clock (PCLK)

The frequency of the PCLK output signal of the GS1660 is determined by the output data rate and the  $\overline{20\text{bit}/10\text{bit}}$  pin setting. Table 4-6 lists the output signal formats according to the data format selected in Manual mode ( $\overline{\text{AUTO/MAN}}$  bit in the host interface is set LOW), or detected in Auto mode ( $\overline{\text{AUTO/MAN}}$  bit in the host interface is set HIGH).

**Table 4-6: GS1660 PCLK Output Rates**

Output Data Format	Pin/Control Bit Settings				PCLK Rate
	$\overline{20\text{bit}/10\text{bit}}$	RATE_DET	$\overline{\text{SMPTE\_BYPASS}}$	DVB-ASI	
20-bit demultiplexed HD format	HIGH	LOW	HIGH	–	74.25 or 74.25/1.001MHz
20-bit data output HD format	HIGH	LOW	LOW	–	74.25 or 74.25/1.001MHz
20-bit demultiplexed SD format	HIGH	HIGH	HIGH	LOW	13.5MHz
20-bit data output SD format	HIGH	HIGH	LOW	LOW	13.5MHz
10-bit multiplexed HD format	LOW	LOW	HIGH	–	148.5 or 148.5/1.001MHz
10-bit data output HD format	LOW	LOW	LOW	–	148.5 or 148.5/1.001MHz
10-bit multiplexed SD format	LOW	HIGH	HIGH	LOW	27MHz
10-bit data output SD format	LOW	HIGH	LOW	LOW	27MHz
10-bit ASI output SD format	LOW	HIGH	LOW	HIGH	27MHz

## 4.9 Timing Signal Generator

The GS1660 has an internal timing signal generator which is used to generate digital FVH timing reference signals, to detect and correct certain error conditions and automatic video standard detection.

The timing signal generator is only operational in SMPTE mode ( $\overline{\text{SMPTE\_BYPASS}} = \text{HIGH}$ ).

The timing signal generator consists of a number of counters and comparators operating at video pixel and video line rates. These counters maintain information about the total line length, active line length, total number of lines per field/frame and total active lines per field/frame for the received video standard.

It takes one video frame to obtain full synchronization to the received video standard.

**NOTE:** Both 8-bit and 10-bit TRS words are identified by the device. Once synchronization has been achieved, the timing signal generator continues to monitor the received TRS timing information to maintain synchronization.

The timing signal generator re-synchronizes all pixel and line based counters on every received TRS ID. Note that for correct operation of the timing signal generator, the SW\_EN input pin must be set LOW, unless manual synchronous switching is enabled (Section 4.9.1).

### 4.9.1 Manual Switch Line Lock Handling

The principle of switch line lock handling is that the switching of synchronous video sources will only disturb the horizontal timing and alignment, whereas the vertical timing remains in synchronization - i.e. switching between video sources of the same format.

To account for the horizontal disturbance caused by a synchronous switch, the word alignment block and timing signal generator automatically re-synchronizes to the new timing immediately if the synchronous switch happens during the designated switch line, as defined in SMPTE recommended practice RP168-2002.

The device samples the SW\_EN pin on every PCLK cycle. When a Logic LOW to HIGH transition on this pin is detected anywhere within the active line, the word alignment block and timing signal generator re-synchronizes immediately to the next TRS word.

This allows the system to force immediate lock on any line, if the switch point is non-standard.

To ensure proper switch line lock handling, the SW\_EN signal should be asserted HIGH anywhere within the active portion of the line on which the switch has taken place, and should be held HIGH for approximately one video line. After this time period, SW\_EN should be de-asserted. SW\_EN should be held LOW during normal device operation.

**NOTE:** It is the rising edge of the SW\_EN signal, which generates the switch line lock re-synchronization. This edge must be in the active portion of the line containing the video switch point.

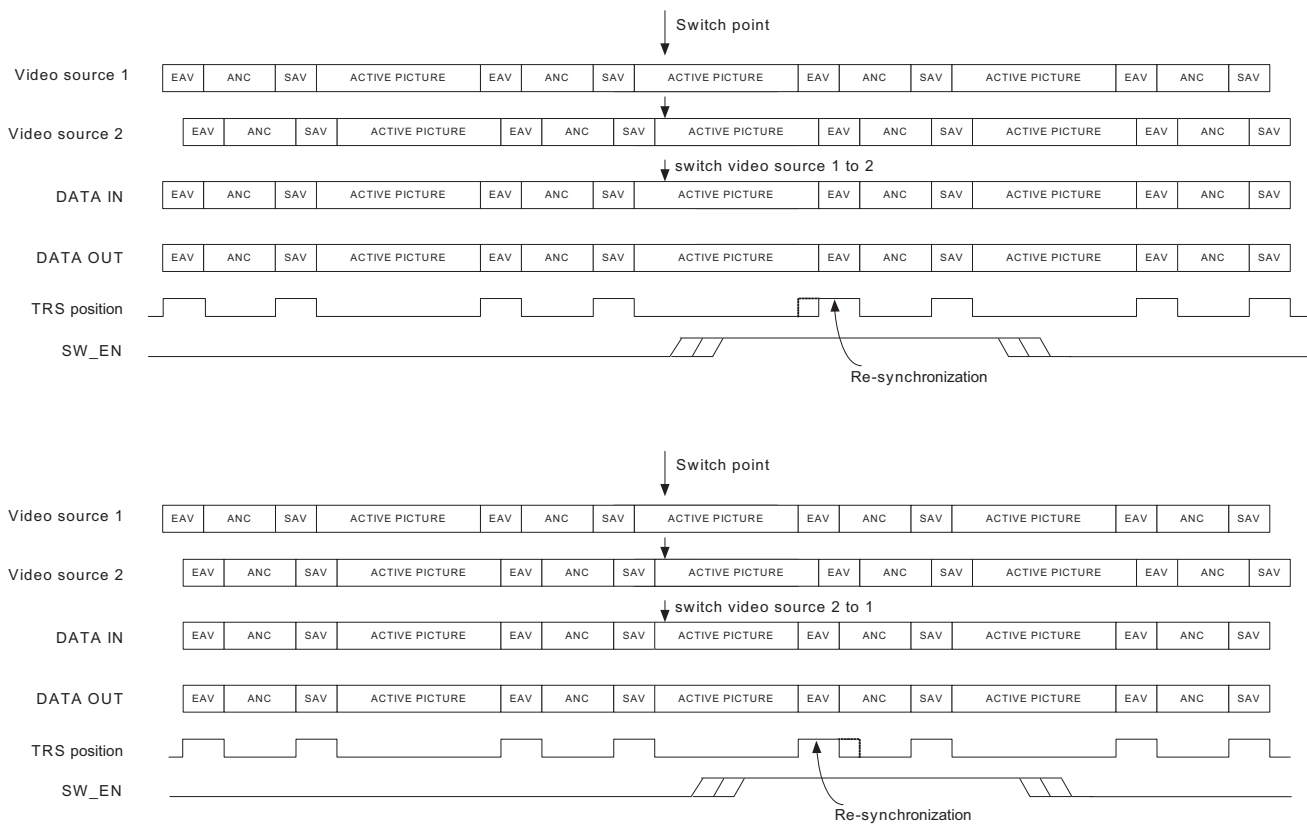

Figure 4-4: Switch Line Locking on a Non-Standard Switch Line

## 4.9.2 Automatic Switch Line Lock Handling

The synchronous switch point is defined for all major video standards in SMPTE RP168-2002. The device automatically re-synchronizes the word alignment block and timing signal generator at the switch point, based on the detected video standard.

The device, as described in Section 4.9.1 and Figure 4-4 above, implements the re-synchronization process automatically, every field/frame. The switch line is defined as follows:

- For 525 line interlaced systems: resynchronization takes place at then end of lines 10 & 273
- For 525 line progressive systems: resynchronization takes place at then end of line 10
- For 625 line interlaced systems: resynchronization takes place at then end of lines 6 & 319
- For 625 line progressive systems: resynchronization takes place at then end of line 6
- For 750 line progressive systems: resynchronization takes place at then end of line 7
- For 1125 line interlaced systems: resynchronization takes place at then end of lines 7 & 568
- For 1125 line progressive systems: resynchronization takes place at then end of line 7

**NOTE:** Unless indicated by SMPTE 352M payload identifier packets, the GS1660 does not distinguish between 1125-line progressive segmented-frame (PsF) video and 1125-line interlaced video operating at 25 or 30fps. However, PsF video operating at 24fps is detected by the device.

A full list of all major video standards and switching lines is shown in [Table 4-7](#).

**Table 4-7: Switch Line Position for Digital Systems**

System	Frame Rate & Structure	Pixel Structure		Signal Standard	Parallel Interface	Serial Interface	Line No.
1125	60/I	1920x1080	4:2:2	274M + RP211		292	7/569
	50/I			274M + RP211			
	30/P			274M + RP211			7
	25/P			274M + RP211			
	24/P			274M + RP211			
	30/PsF			274M + RP211			
	25/PsF			274M + RP211			
	24/PsF			274M + RP211			
750	60/P	1280x720	4:2:2	296M		292	7
	50/P			296M			
	30/P			296M			
	25/P			296M			
	24/P			296M			
625	50/P	720x576	4:2:2	BT.1358	349M	292	6
				BT.1358	347M	344M	
				BT.1358	BT.1358	BT.1362	
			4:2:0	BT.1358	349M	292	
				BT.1358	BT.1358	BT.1362	
				50/I	960x576	4:2:2	
	BT.601	BT.656	259M				
	720x576	4:4:4:4	BT.799		349M	292	
			BT.799		347M	344M	
			BT.799		BT.799	344M	
			BT.799		BT.799	-	
		4:2:2	BT.601		349M	292	
	BT.601		125M	259M			

**Table 4-7: Switch Line Position for Digital Systems (Continued)**

System	Frame Rate & Structure	Pixel Structure		Signal Standard	Parallel Interface	Serial Interface	Line No.
525	59.94/P	720x483	4:2:2	293M	349M	292	10
				293M	347M	344M	
				293M	293M	294M	
		4:2:0	293M	349M	292		
			293M	293M	294M		
	59.94/I	960x483	4:2:2	267M	349M	292	10/273
				267M	267M	259M	
		720x483	4:4:4	267M	349M	292	
				267M	347M	344M	
				267M	RP174	344M	
267M				RP175	RP175		
4:2:2	125M	349M	292				
	125M	125M	259M				
HD-SDTI	P or PsF structure	1920x1080	4:2:2	274M	274M + 348M	292	7
	I structure			274M			7/569
	P structure	1280x720		296M	296M + 348M		7
SDTI	50/I	720x576	4:2:2	BT.656	BT.656 + 305M	259M	6/319
	59.94/I	720x483		125M	125M + 305M		10/273

## 4.10 Programmable Multi-function Outputs

The GS1660 has 6 multi-function output pins, STAT [5:0], which are programmable via the host interface to output one of the following signals:

**Table 4-8: Output Signals Available on Programmable Multi-Function Pins**

Status Signal	Selection Code	Default Output Pin
H/HSYNC (according to TIM_861 Pin) <a href="#">Section 4.11</a>	0000	STAT 0
V/VSYNC (according to TIM_861 Pin) <a href="#">Section 4.11</a>	0001	STAT 1
F/DE (according to TIM_861 Pin) <a href="#">Section 4.11</a>	0010	STAT 2
LOCKED <a href="#">Section 4.6</a>	0011	STAT 3
Y/1ANC <a href="#">Section 4.16</a>	0100	STAT 4
C/2ANC <a href="#">Section 4.16</a>	0101	–
$\overline{\text{DATA ERROR}}$ <a href="#">Section 4.15</a>	0110	STAT 5
$\overline{\text{VIDEO ERROR}}$	0111	–
EDH DETECTED	1001	–
CARRIER DETECT	1010	–
RATE_DET	1011	–

**NOTE:**

Each of the STAT[5:0] pins are configurable individually using the register bits in the host interface; STAT[5:0]\_CONFIG (008h/009h).

## 4.11 H:V:F Timing Signal Generation

The GS1660 extracts critical timing parameters from the received TRS words.

Horizontal blanking (H), Vertical blanking (V), and Field odd/even (F) timing are output on the STAT[2:0] pins by default.

Using the H\_CONFIG bit in the host interface, the H signal timing can be selected as one of the following:

1. Active line blanking (H\_CONFIG = LOW) - the H output is HIGH for the horizontal blanking period, including the EAV TRS words.
2. TRS based blanking (H\_CONFIG = HIGH) - the H output is set HIGH for the entire horizontal blanking period as indicated by the H bit in the received TRS signals.

The timing of these signals is shown in the figures below.

**NOTE:** Both 8-bit and 10-bit TRS words are identified by the device.

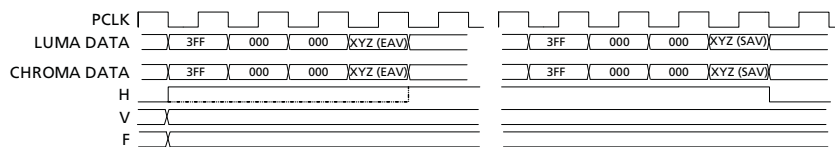

Figure 4-5: H:V:F Output Timing - HDTV 20-bit Mode

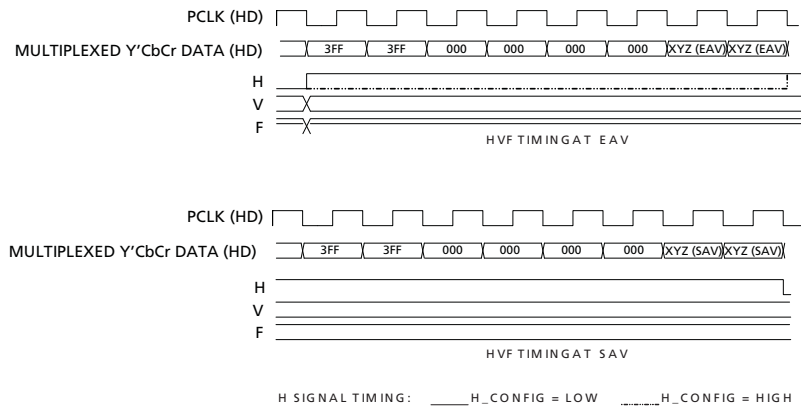

Figure 4-6: H:V:F Output Timing - HDTV 10-bit Mode

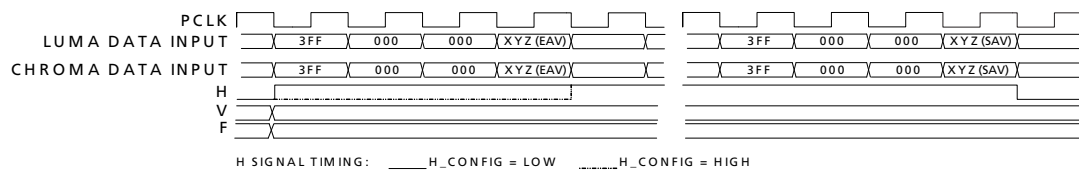

Figure 4-7: H:V:F Output Timing - HD 20-bit Output Mode

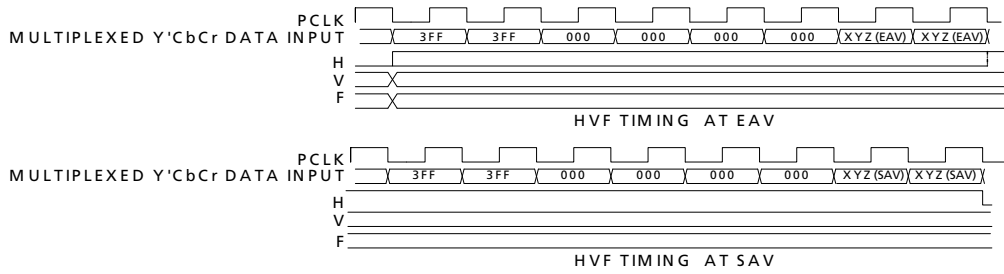

Figure 4-8: H:V:F Output Timing - HD 10-bit Output Mode

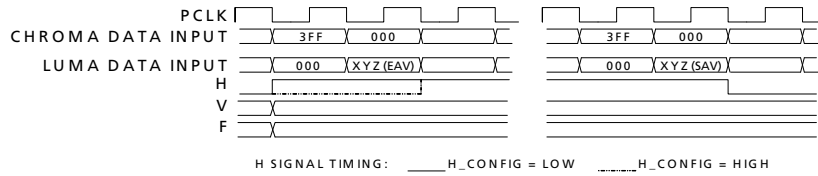

Figure 4-9: H:V:F Output Timing - SD 20-bit Output Mode

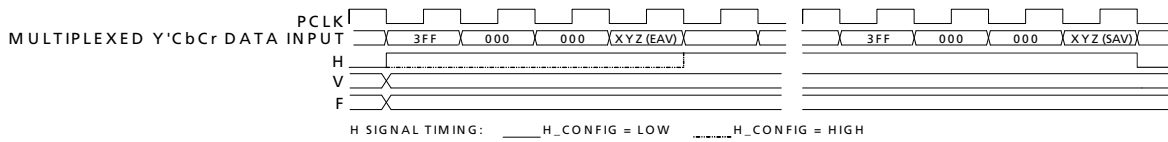

Figure 4-10: H:V:F Output Timing - SD 10-bit Output Mode

### 4.11.1 CEA-861 Timing Generation

The GS1660 is capable of generating CEA 861 timing instead of SMPTE HVF timing for all of the supported video formats.

This mode is selected when the TIM\_861 pin is HIGH.

Horizontal sync (HSYNC), Vertical sync (VSYNC), and Data Enable (DE) timing are output on the STAT[2:0] pins by default.

Table 4-9 shows the CEA-861 formats supported by the GS1660:

Table 4-9: Supported CEA-861 Formats

Format	CEA-861 Format	VD_STD[5:0]
720(1440) x 480i @ 59.94/60Hz	6 & 7	16h, 17h, 19h, 1Bh
720(1440) x 576i @ 50Hz	21 & 22	18h, 1Ah
1280 x 720p @ 59.94/60Hz	4	20h, 00h
1280 x 720p @ 50Hz	19	24h, 04h
1920 x 1080i @ 59.94/60Hz	5	2Ah, 0Ah
1920 x 1080i @ 50Hz	20	2Ch, 0Ch



**Table 4-9: Supported CEA-861 Formats (Continued)**

Format	CEA-861 Format	VD_STD[5:0]
1920 x 1080p @ 29.97/30Hz	34 <sup>1</sup>	2Bh, 0Bh
1920 x 1080p @ 25Hz	33 <sup>2</sup>	2Dh, 0Dh
1920 x 1080p @ 23.98/24Hz	32	30h, 10h

NOTES:  
 1,2: Timing is identical for the corresponding formats.

**4.11.1.1 Vertical Timing**

When CEA861 timing is selected, the device will output standards compliant CEA861 timing signals as shown in the figures below; for example 240 active lines per field for SMPTE 125M.

The register bit TRS\_861 is used to select DFP timing generator mode which follows the vertical blanking timing as defined by the embedded TRS code words.

The timing of the CEA 861 timing reference signals can be found in the CEA 861 specifications. For information, they are included in the following diagrams. These diagrams may not be comprehensive.

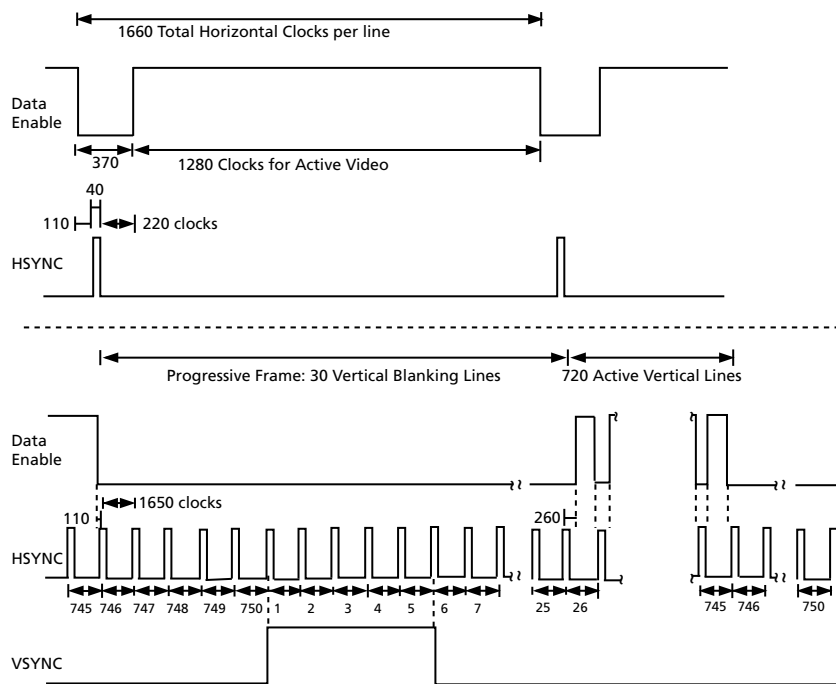

Figure 4-11: H:V:DE Output Timing 1280 x 720p @ 59.94/60 (Format 4)

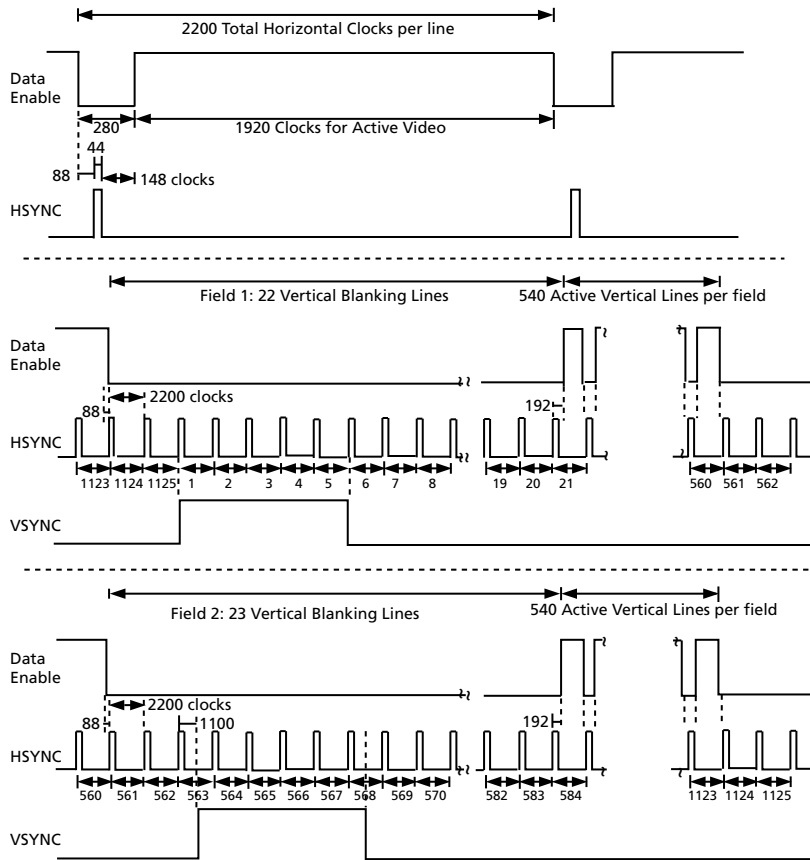

Figure 4-12: H:V:DE Output Timing 1920 x 1080i @ 59.94/60 (Format 5)

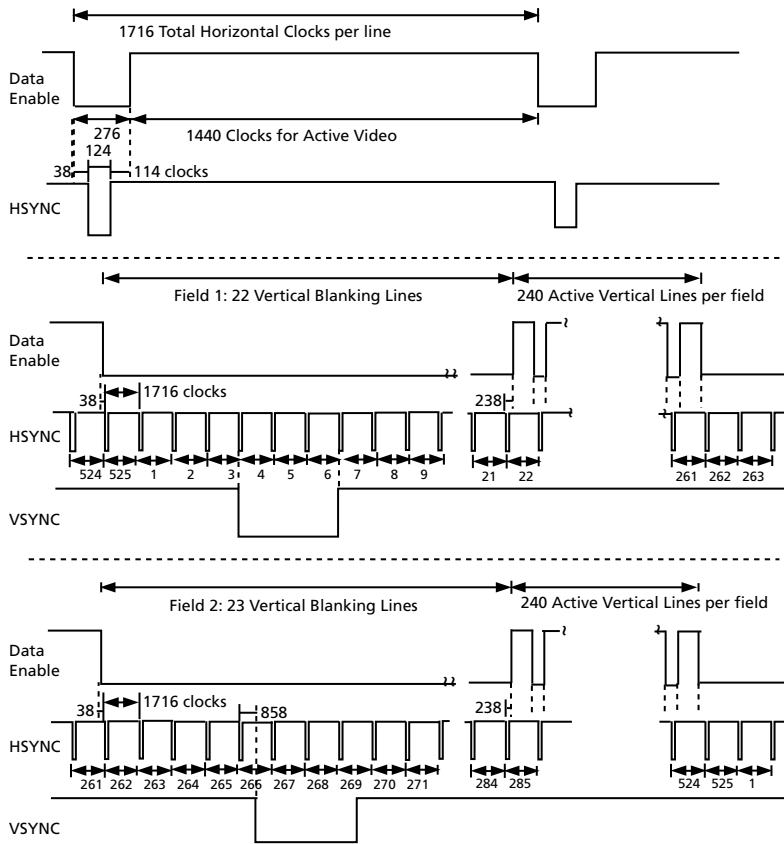

Figure 4-13: H:V:DE Output Timing 720 (1440) x 480i @ 59.94/60 (Format 6&7)

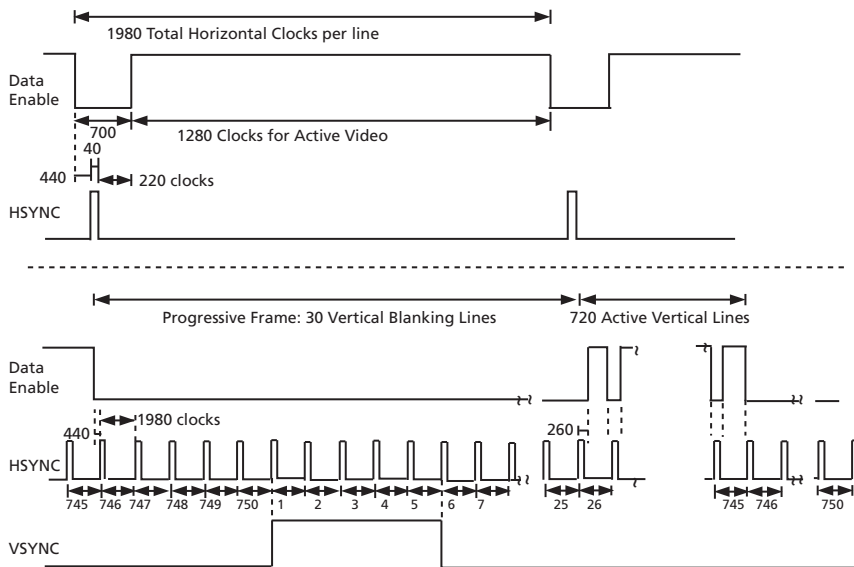

Figure 4-14: H:V:DE Output Timing 1280 x 720p @ 50 (Format 19)

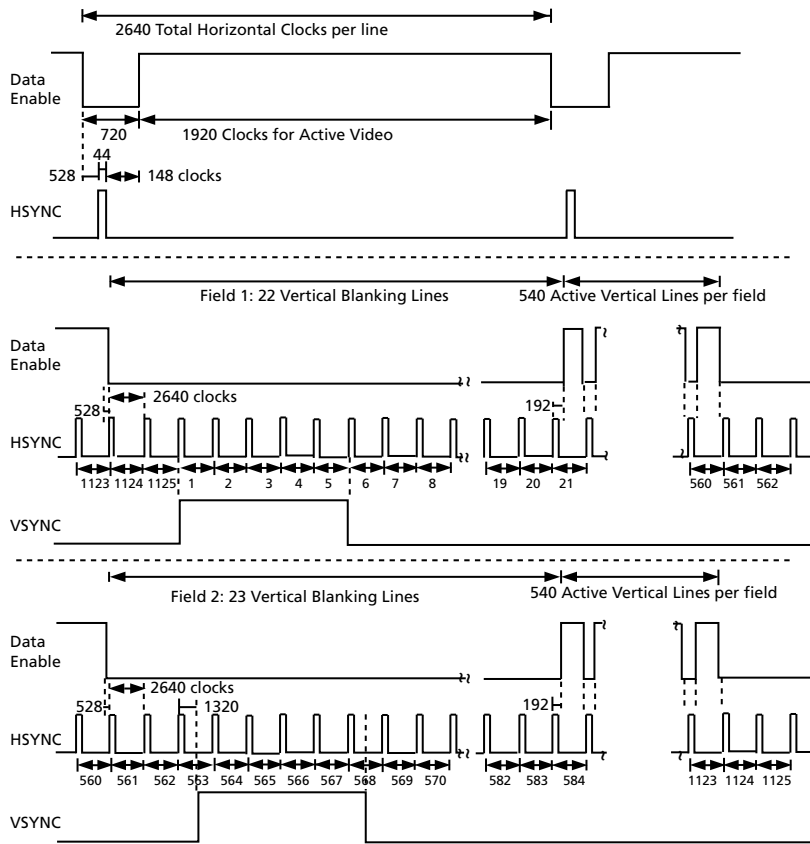

Figure 4-15: H:V:DE Output Timing 1920 x 1080i @ 50 (Format 20)

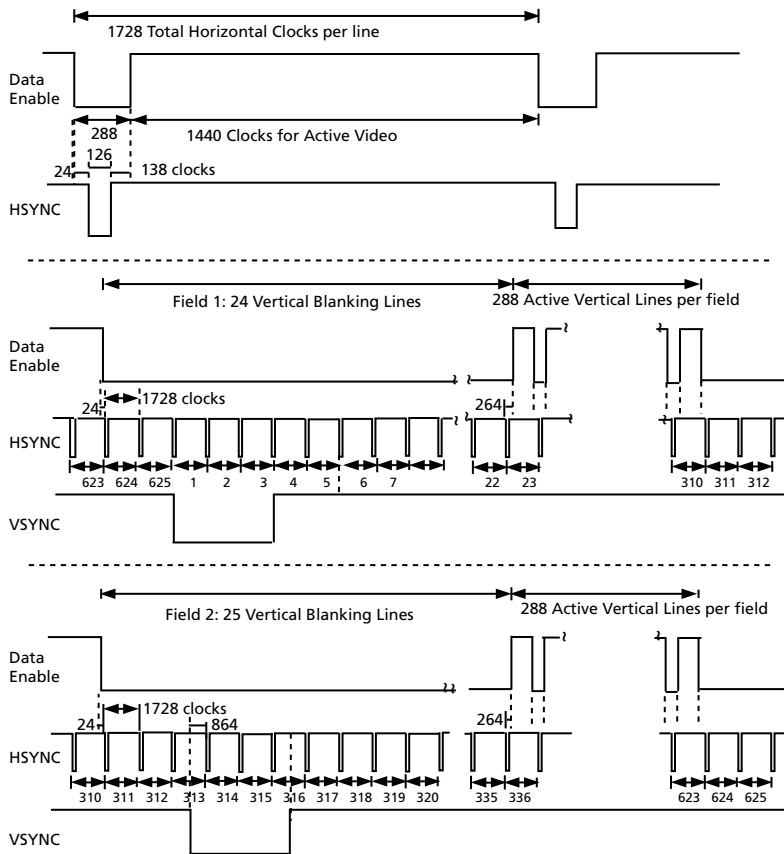

Figure 4-16: H:V:DE Output Timing 720 (1440) x 576 @ 50 (Format 21 & 22)

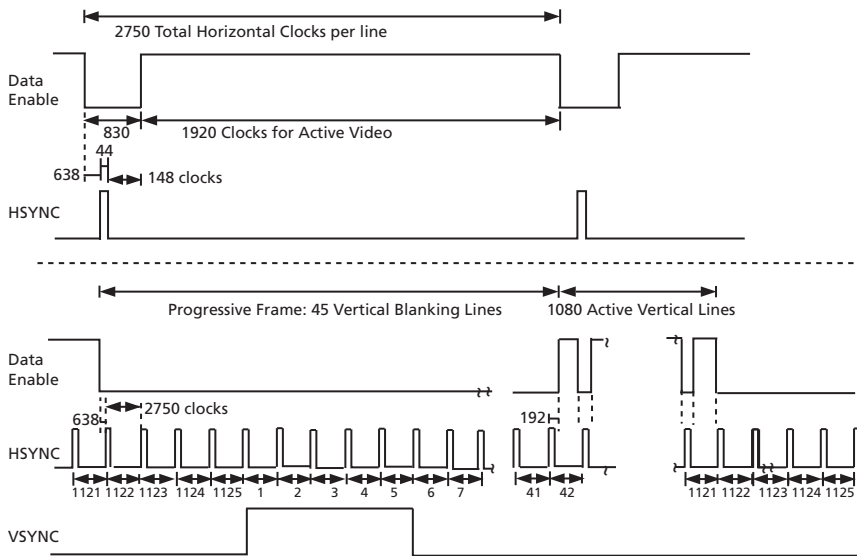

Figure 4-17: H:V:DE Output Timing 1920 x 1080p @ 23.94/24 (Format 32)

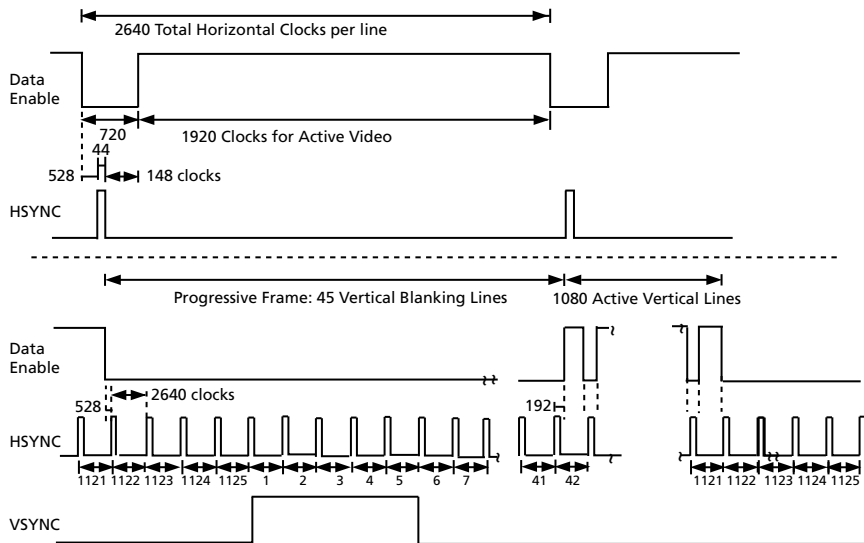

Figure 4-18: H:V:DE Output Timing 1920 x 1080p @ 25 (Format 33)

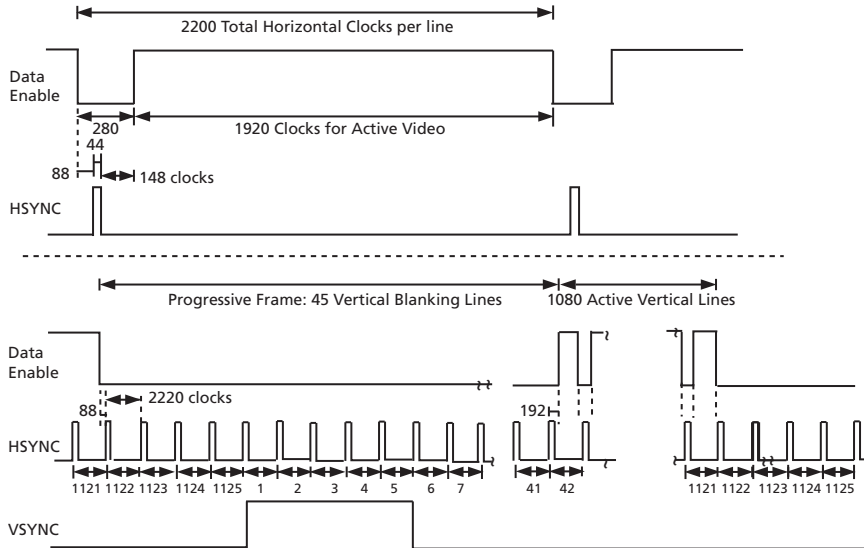

Figure 4-19: H:V:DE Output Timing 1920 x 1080p @ 29.97/30 (Format 34)

## 4.12 Automatic Video Standards Detection

Using the timing extracted from the received TRS signals, the GS1660 is able to identify the received video standard.

The total samples per line, active samples per line, total lines per field/frame and active lines per field/frame are all measured.

Four registers are provided to allow the system to read the video standard information from the device. These raster structure registers are provided in addition to the VIDEO\_FORMAT\_352\_A\_X and VIDEO\_FORMAT\_352\_B\_X registers, and are updated once per frame at the end of line 12.

The raster structure registers also contain three status bits: STD\_LOCK, INT/ $\overline{\text{PROG}}$  and M. The STD\_LOCK bit is set HIGH whenever the timing signal generator is fully synchronized to the incoming standard, and detects it as one of the supported formats. The INT/ $\overline{\text{PROG}}$  bit is set HIGH if the detected video standard is interlaced and LOW if the detected video standard is progressive. M is set HIGH if the clock frequency includes the “1000/1001” factor denoting a 23.98, 29.97 or 59.94Hz frame rate.

The video standard code is reported in the VD\_STD bits of the host interface register.

Table 4-10 describes the 5-bit codes for the recognized video standards.

**Table 4-10: Supported Video Standard Codes**

SMPTE Standard	Active Video Area	RATE_DET SD/HD	Lines per Field	Active Lines per Field	Words per Active Line	Words per Line	VD_STD [5:0]
260M (HD)	1920x1035/60 (2:1)	0	1125	1035	1920	2200	15h
259M (HD)	1920x1080/50 (2:1)	0	1250	1080	1920	2376	14h
274M (HD)	1920x1080/60 (2:1) or 1920x1080/30 (PsF)	0	1125	1080	1920	2200	0Ah
	1920x1080/50 (2:1) or 1920x1080/25 (PsF)	0	11252	1080	1920	2640	0Ch
	1920x1080/30 (1:1)	0	1125	1080	1920	2200	0Bh
	1920x1080/25 (1:1)	0	1125	1080	1920	2640	0Dh
	1920x1080/24 (1:1)	0	1125	1080	1920	2750	10h
	1920x1080/24 (PsF)	0	1125	1080	1920	2750	11h
	1920x1080/25 (1:1) –	0	1125	1080	2304	2640	0Eh
	1920x1080/25 (PsF) – EM	0	1125	1080	2304	2640	0Fh
	1920x1080/24 (1:1) –	0	1125	1080	2400	2750	12h
	1920x1080/24 (PsF) – EM	0	1125	1080	2400	2750	13h
296M (HD)	1280x720/30 (1:1)	0	750	720	1280	3300	02h
	1280x720/30 (1:1) – EM	0	750	720	2880	3300	03h
	1280x720/50 (1:1)	0	750	720	1280	1980	04h

**Table 4-10: Supported Video Standard Codes (Continued)**

SMPTE Standard	Active Video Area	RATE_DET SD/HD	Lines per Field	Active Lines per Field	Words per Active Line	Words per Line	VD_STD [5:0]
296M (HD)	1280x720/50 (1:1) – EM	0	750	720	1728	1980	05h
	1280x720/25 (1:1)	0	750	720	1280	3960	06h
	1280x720/25 (1:1) – EM	0	750	720	3456	3960	07h
	1280x720/24 (1:1)	0	750	720	1280	4125	08h
	1280x720/24 (1:1) – EM	0	750	720	3600	4125	09h
	1280x720/60 (1:1)	0	750	720	1280	1650	00h
	1280x720/60 (1:1) – EM	0	750	720	1440	1650	01h
125M (SD)	1440x487/60 (2:1)	1	525	244 or 243	1440	1716	16h
	1440x507/60	1	525	254 or 253	1440	1716	17h
	525-line 487 generic	1	525	–	–	1716	19h
	525-line 507 generic	1	525	–	–	1716	1Bh
ITU-R BT.656 (SD)	1440x576/50 (2:1) Or dual link progressive)	1	625	–	1440	1728	18h
	625-line generic	1	625	–	–	1728	1Ah
Unknown HD	SD/HD = 0	0	–	–	–	–	1Dh
Unknown SD	SD/HD = 1	1	–	–	–	–	1Eh

Notes:

1. The Line Numbers in brackets refer to version zero SMPTE 352M packet locations, if they are different from version 1.
2. The part may provide full or limited functionality with standards that are not included in this table. Please consult a Semtech technical representative.
3. For SD-SDI streams, the device can report an incorrect M value when SMPTE-352M packets are present.

**NOTE:** In certain systems, due to greater ppm offsets in the crystal, the 'M' bit may not assert properly. In such cases, bits 3:0 in Register 06Fh can be increased to a maximum value of 4.

By default (after power up or after systems reset), the four RASTER\_STRUCTURE, VD\_STD, STD\_LOCK and INT/PROG fields are set to zero. These fields are also cleared when the SMPTE\_BYPASS pin is LOW.



## 4.13 Data Format Detection & Indication

In addition to detecting the video standard, the GS1660 detects the data format, i.e. SDTI, SDI, TDM data (SMPTE 346M), etc.

This information is represented by bits in the DATA\_FORMAT\_DSX register accessible through the host interface.

Data format detection is only be carried out when the LOCKED signal is HIGH.

By default (at power up or after system reset), the DATA\_FORMAT\_DSX register is set to Fh (undefined). This register is also set as undefined when the LOCKED signal is LOW and/or the SMPTE\_BYPASS pin is LOW.

**Table 4-11: Data Format Register Codes**

YDATA_FORMAT[3:0] or CDATA_FORMAT[3:0]	Data Format	Remarks
0h ~ 05h	SDTI	SMPTE 321M, SMPTE 322M, SMPTE 326M
6h	SDI	–
7h	Reserved	–
8h	TDM	SMPTE 346M
9h	HD-SDTI	–
Ah ~ Eh	Reserved	–
Fh	Non-SMPTE data format	Detected data format is not SMPTE. <u>SMPTE_BYPASS</u> = LOW <i>or</i> LOCKED = LOW

The data format is determined using the following criteria:

- If TRS ID words are detected but no SDTI header or TDM header is detected, then the data format is SDI
- If TRS ID words are detected and the SDTI header is available then the format is SDTI
- If TRS ID words are detected and the TDM data header is detected then the format is TDM video
- No TRS words are detected, but the PLL is locked, then the data format is unknown

**NOTE:** Two data format sets are provided for HD video rates. This is because the Y and Cr/Cb channels can be used separately to carry SDTI data streams of different data formats. In SD video mode, only the Y data format register contains the data, and the C register is set to Fh (undefined format).

## 4.14 EDH Detection

### 4.14.1 EDH Packet Detection

The GS1660 determines if EDH packets are present in the incoming video data and asserts the EDH\_DETECT status according to the SMPTE standard.

EDH\_DETECT is set HIGH when EDH packets have been detected and remains HIGH until EDH packets are no longer present. It is set LOW at the end of the vertical blanking (falling edge of V) if an EDH packet has not been detected during vertical blanking.

EDH\_DETECT can be programmed to be output on the multi-function output port pins. The EDH\_DETECT bit is also available in the host interface.

### 4.14.2 EDH Flag Detection

The EDH flags for ancillary data, active picture, and full field regions are extracted from the detected EDH packets and placed in the EDH\_FLAG\_IN register.

When the EDH\_FLAG\_UPDATE\_MASK bit in the host interface is set HIGH, the GS1660 updates the Ancillary Data, Full Field, and Active Picture EDH flags according to SMPTE RP165. The updated EDH flags are available in the EDH\_FLAG\_OUT register. The EDH packet output from the device contains these updated flags.

One set of flags is provided for both fields 1 and 2. The field 1 flag data is overwritten by the field 2 flag data.

When EDH packets are not detected, the UES flags in the EDH\_FLAG\_OUT register are set HIGH to signify that the received signal does not support Error Detection and Handling. In addition, the EDH\_DETECT bit is set LOW. These flags are set regardless of the setting of the EDH\_FLAG\_UPDATE\_MASK bit.

EDH\_FLAG\_OUT and EDH\_FLAG\_IN may be read via the host interface at any time during the received frame except on the lines defined in SMPTE RP165, when these flags are updated.

The GS1660 indicates the CRC validity for both active picture and full field CRCs. The AP\_CRC\_V bit in the host interface indicates the active picture CRC validity, and the FF\_CRC\_V bit indicates the full field CRC validity. When EDH\_DETECT = LOW, these bits are cleared.

The EDH\_FLAG\_OUT and EDH\_FLAG\_IN register values remain set until overwritten by the decoded flags in the next received EDH packet. When an EDH packet is not detected during vertical blanking, the flag registers are cleared at the end of the vertical blanking period.

## 4.15 Video Signal Error Detection & Indication

The GS1660 includes a number of video signal error detection functions. These are provided to enhance operation of the device when operating in SMPTE mode ( $\overline{\text{SMPTE\_BYPASS}} = \text{HIGH}$ ). These features are not available in the other operating modes of the device (i.e. when  $\overline{\text{SMPTE\_BYPASS}} = \text{LOW}$ ).

Signal errors that can be detected include:

1. TRS errors.
2. HD line based CRC errors.
3. EDH errors.
4. HD line number errors.
5. Video standard errors.

The device maintains an ERROR\_STAT\_X register. Each error condition has a specific flag in the ERROR\_STAT\_X register, which is set HIGH whenever an error condition is detected.

An ERROR\_MASK register is also provided, allowing the user to select which error conditions are reported. Each bit of the ERROR\_MASK register corresponds to a unique error type.

Each bit of each ERROR\_MASK register corresponds to a unique error type.

By default (at power up or after system reset), all bits of the ERROR\_MASK registers are zero, enabling all errors to be reported. Individual error detection may be disabled by setting the corresponding bit HIGH in the mask registers.

Error conditions are indicated by a  $\overline{\text{DATA\_ERROR}}$  signal, which is also available on the multifunction I/O pins. This signal is normally HIGH, but is set LOW by the device when an error condition has been detected.

This signal is a logical 'NOR' of the appropriate error status flags stored in the ERROR\_STAT\_X register, which are gated by the bit settings in the ERROR\_MASK registers. When an error status bit is HIGH and the corresponding error mask bit is LOW, the corresponding  $\overline{\text{DATA\_ERROR}}$  signal is set LOW by the device.

The ERROR\_STAT\_X registers, and correspondingly the  $\overline{\text{DATA\_ERROR}}$  signal, are cleared at the start of the next video field or when read via the host interface, whichever condition occurs first.

All bits of the ERROR\_STAT\_X registers are also cleared under any of the following conditions:

1. LOCKED signal = LOW.
2.  $\overline{\text{SMPTE\_BYPASS}} = \text{LOW}$ .
3. When a change in video standard has been detected.
4.  $\overline{\text{RESET\_TRST}} = \text{LOW}$

Table 4-12 shows the ERROR\_STAT\_X register and ERROR\_MASK\_X register.

**NOTE:** Since the error indication registers are cleared once per field, if an external host micro is polling the error registers periodically, an error flag may be missed if it is intermittent, and the polling frequency is less than the field rate.

**Table 4-12: Error Status Register and Error Mask Register**

Video Error Status Register	Video Error Mask Register
SAV_ERR (02h, 03h)	SAV_ERR_MASK (037h, 038h)
EAV_ERR (02h, 03h)	EAV_ERR_MASK (037h, 038h)
YCRC_ERR (02h, 03h)	YCRC_ERR_MASK (037h, 038h)
CCRC_ERR (02h, 03h)	CCRC_ERR_MASK (037h, 038h)
LNUM_ERR (02h, 03h)	LNUM_ERR_MASK (037h, 038h)
YCS_ERR (02h, 03h)	YCS_ERR_MASK (037h, 038h)
CCS_ERR (02h, 03h)	CCS_ERR_MASK (037h, 038h)
AP_CRC_ERR (02h)	AP_CRC_ERR_MASK (037h)
FF_CRC_ERR (02h)	FF_CRC_ERR_MASK (037h)
VD_STD_ERR (02h, 03h)	VD_STD_ERR_MASK (037h)

### 4.15.1 TRS Error Detection

TRS error flags are generated by the GS1660 under the following two conditions:

1. A phase shift in received TRS timing is observed on a non-switching line.
2. The received TRS Hamming codes are incorrect.

Both SAV and EAV TRS words are checked for timing and data integrity errors.

For HD mode, only the Y channel TRS codes are checked for errors.

Both 8-bit and 10-bit TRS code words are checked for errors.

The SAV\_ERR bit of the ERROR\_STAT\_X register is set HIGH when an SAV TRS error is detected.

The EAV\_ERR bit of the ERROR\_STAT\_X register is set HIGH when an EAV TRS error is detected.

### 4.15.2 Line Based CRC Error Detection

The GS1660 calculates line based CRCs for HD video signals. CRC calculations are done for each 10-bit channel (Y and C for HD video).

These calculated CRC values are compared with the received CRC values.

If a mismatch in the calculated and received CRC values is detected for Y channel data, the YCRC\_ERR bit in the ERROR\_STAT\_X register is set HIGH.

If a mismatch in the calculated and received CRC values is detected for C channel data, the CCRC\_ERR bit in the ERROR\_STAT\_X register is set HIGH.

Y or C CRC errors are also generated if CRC values are not embedded.

Line based CRC errors are only generated when the device is operating in HD mode.

**NOTE:** By default, 8-bit to 10-bit TRS remapping is enabled. If an 8-bit input is used, the HD CRC check is based on the 10-bit remapped value, not the 8-bit value, so the CRC Error Flag is incorrectly asserted and should be ignored. If 8-bit to 10-bit remapping is enabled, then CRC correction and insertion should be enabled by setting the CRC\_INS\_MASK bit in the IOPROC\_DISABLE register LOW. This ensures that the CRC values are updated.

### 4.15.3 EDH CRC Error Detection

The GS1660 also calculates Full Field (FF) and Active Picture (AP) CRC's according to SMPTE RP165 in support of Error Detection and Handling packets in SD signals.

These calculated CRC values are compared with the received CRC values.

Error flags for AP and FF CRC errors are provided and each error flag is a logical OR of the field 1 and field 2 error conditions.

The AP\_CRC\_ERR bit in the VIDEO\_ERROR\_STAT\_X register is set HIGH when an Active Picture CRC mismatch has been detected in field 1 or 2.

The FF\_CRC\_ERR bit in the VIDEO\_ERROR\_STAT\_X register is set HIGH when a Full Field CRC mismatch has been detected in field 1 or 2.

EDH CRC errors are only indicated when the device is operating in SD mode and when the device has correctly received EDH packets.

### 4.15.4 HD Line Number Error Detection

If a mismatch in the calculated and received line numbers is detected, the LNUM\_ERR bit in the VIDEO\_ERROR\_STAT\_X register is set HIGH.

## 4.16 Ancillary Data Detection & Indication

The GS1660 detects ancillary data in both the vertical and horizontal ancillary data spaces. Status signal outputs Y/1ANC and C/2ANC are provided to indicate the position of ancillary data in the output data streams. These signals may be selected on the multi-function I/O port pins (STAT[5:0]).

The GS1660 indicates the presence of all types of ancillary data by detecting the 000h, 3FFh, 3FFh (00h, FFh, FFh for 8-bit video) ancillary data preamble.

**NOTE:** Both 8 and 10-bit ancillary data preambles are detected by the device.

By default (at power up or after system reset) the GS1660 indicates all types of ancillary data. Up to 5 types of ancillary data can be specifically programmed for recognition.

For HD video signals, ancillary data may be placed in both the Y and Cb/Cr video data streams separately. For SD video signals, the ancillary data is multiplexed and combined into the YCbCr data space.

When operating in HD mode, the Y/1ANC signal is HIGH whenever ancillary data is detected in the Luma data stream, and C/2ANC is HIGH whenever ancillary data is detected in the Chroma data stream. The signals are asserted HIGH at the start of the ancillary data preamble, and remain HIGH until after the ancillary data checksum.

When operating in SD mode, the Y/1ANC and C/2ANC signals depend on the output data format. For 20-bit demultiplexed data, the Y/1ANC and C/2ANC signals operate independently to indicate the first and last ancillary Data Word position in the Luma and/or Chroma data streams. For 10-bit multiplexed data, the Y/1ANC signal is HIGH whenever ancillary data is detected, and the C/2ANC signal is always LOW.

These status signal outputs are synchronous with PCLK and may be used as clock-enables for external logic, or as write-enables for an external FIFO or other memory devices.

The operation of the Y/1ANC and C/2ANC signals is shown below in [Figure 4-20](#).

**NOTE:** When I/O processing is disabled, the Y/1ANC and C/2ANC flags may toggle, but they are invalid and should be ignored.

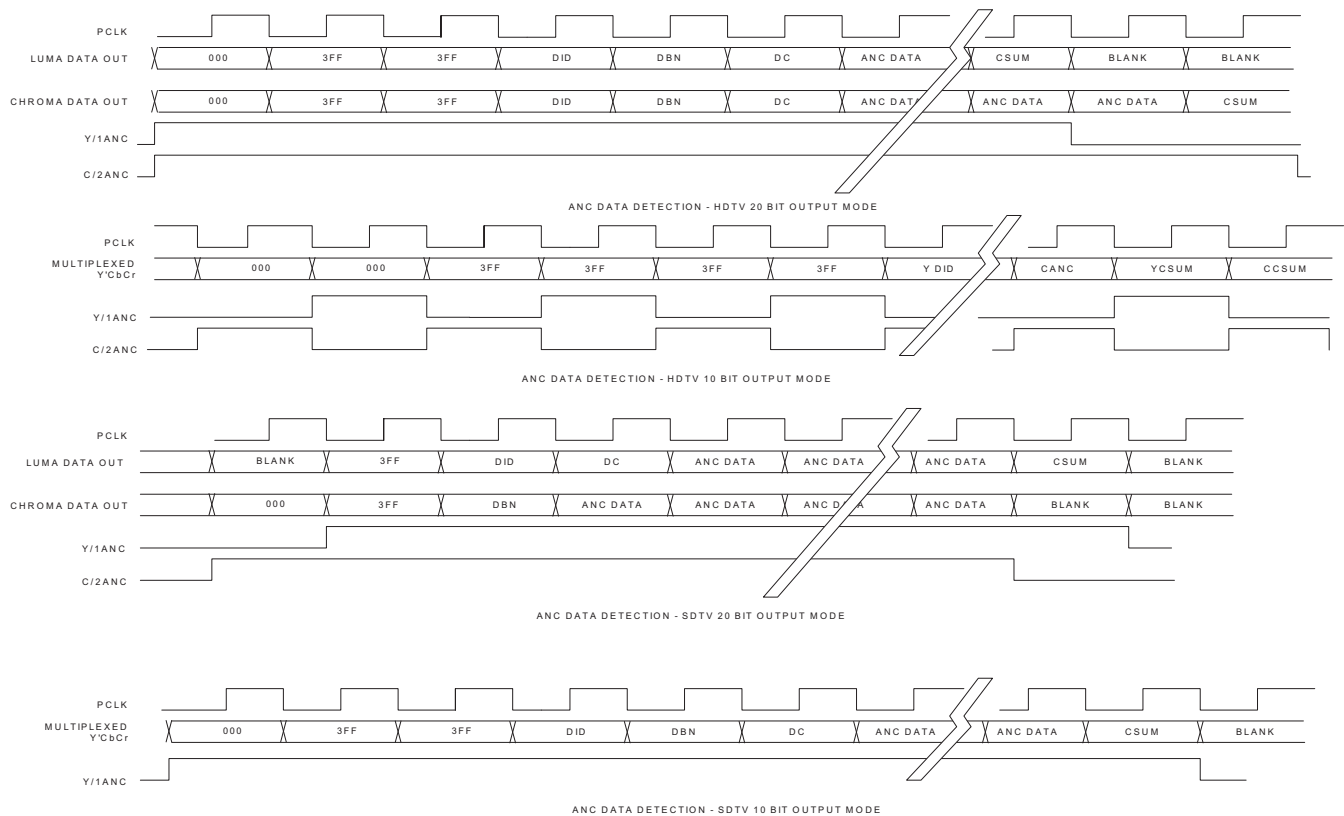

Figure 4-20: Y/1ANC and C/2ANC Signal Timing

### 4.16.1 Programmable Ancillary Data Detection

As described above in [Section 4.16](#), the GS1660 detects and indicates all ancillary data types by default.

It is possible to program which ancillary data types are to be detected and indicated. Up to 5 different ancillary data types may be programmed for detection by the GS1660 in the ANC\_TYPE\_DS1 registers for SD and HD.

When so programmed, the GS1660 only indicates the presence of the specified ancillary data types, ignoring all other ancillary data. For each data type to be detected, the user

must program the DID and/or SDID of that ancillary data type. In the case where no DID or SDID values are programmed, the GS1660 indicates the presence of all ancillary data. In the case where one or more, DID and/or SDID values have been programmed, then only those matching data types are detected and indicated.

The timing of the Y/1ANC and C/2ANC signals in this case is as shown in [Figure 4-20](#).

The GS1660 compares the received DID and/or SDID with the programmed values. If a match is found, ancillary data is indicated.

For any DID or SDID value set to zero, no comparison or match is made. For example, if the DID is programmed and the SDID is not programmed, the GS1660 only detects a match to the DID value.

If both DID and SDID values are non-zero, then the received ancillary data type must match both the DID and SDID before Y/1ANC and/or C/2ANC is set HIGH.

**NOTE:** SMPTE 352M Payload Identifier packets and Error Detection and Handling (EDH) Packets are always detected by the GS1660, irrespective of the settings of the ANC\_TYPE registers.

## 4.16.2 SMPTE 352M Payload Identifier

The GS1660 automatically extracts the SMPTE 352M payload identifier present in the input data stream for SD and HD. The four word payload identifier packets are written to VIDEO\_FORMAT\_352\_A\_X and VIDEO\_FORMAT\_352\_B\_X registers accessible through the host interface.

The device also indicates the version of the payload packet in the VERSION\_352M bit of the DATA\_FORMAT\_DSX register. When the SMPTE 352M packet is formatted as a 'version 1' packet, the VERSION\_352M bit is set HIGH, when the packet is formatted as a 'version 0' packet, this bit is set LOW.

The VIDEO\_FORMAT\_352\_A\_X and VIDEO\_FORMAT\_352\_B\_X registers are only updated if there are no checksum errors in the received SMPTE 352M packets.

By default (at power up or after system reset), the VVIDEO\_FORMAT\_X\_DS1 and VIDEO\_FORMAT\_X\_DS2 bits are set to 0, indicating an undefined format.

### 4.16.2.1 SMPTE 352M Payload Identifier Usage

The SMPTE 352M Payload Identifier is used to confirm the video format identified by the Automatic Video Standards Detection block (see [Section 4.16.4](#))

## 4.16.3 Ancillary Data Checksum Error

The GS1660 calculates checksums for all received ancillary data.

These calculated checksums are compared with the received ancillary data checksum words.

If a mismatch in the calculated and received checksums is detected, then a checksum error is indicated.

When operating in HD mode, the device makes comparisons on both the Y and C channels separately. If an error condition in the Y channel is detected, the YCS\_ERR bit

in the VIDEO\_ERROR\_STAT\_X register is set HIGH. If an error condition in the C channel is detected, the CCS\_ERR bit in the VIDEO\_ERROR\_STAT\_X register is set HIGH.

When operating in SD mode, only the YCS\_ERR bit is set HIGH when checksum errors are detected.

#### 4.16.3.1 Programmable Ancillary Data Checksum Calculation

As described above, the GS1660 calculates and compares checksum values for all ancillary data types by default. It is possible to program which ancillary data types are checked as described in [Section 4.16.1](#).

When so programmed, the GS1660 only checks ancillary data checksums for the specified data types, ignoring all other ancillary data.

The YCS\_ERR and/or CCS\_ERR bits in the VIDEO\_ERROR\_STAT\_X register are only set HIGH if an error condition is detected for the programmed ancillary data types.

#### 4.16.4 Video Standard Error

If a mismatch between the received SMPTE 352M packets and the calculated video standard occurs, the GS1660 indicates a video standard error by setting the VD\_STD\_ERR bit of the VIDEO\_ERROR\_STAT\_X register HIGH.

The device detects the SMPTE 352M Packet version as defined in the SMPTE 352M standard. If the incoming packet is Version Zero, then no comparison is made with the internally generated payload information and the VD\_STD\_ERR bit is not set HIGH.

**NOTE 1:** If the received SMPTE 352M packet indicates 25, 30 or 29.97PsF formats, the device only indicates an error when the video format is actually progressive. The device detects 24 and 23.98PsF video standards and perform error checking at these rates.

**NOTE 2:** VD\_STD\_ERR\_DS1 is set incorrectly for a 1920x1080/PsF/24 payload ID. To resolve this issue, choose one of the two methods.

- Set the VD\_STD\_ERR\_DS1 mask bit high in the ERROR\_MASK\_1 register to avoid having incorrect assertion of the DATA\_ERROR pin.
- Monitor the received SMPTE ST0352 packet in the VIDEO\_FORMAT\_352\_A\_1 and VIDEO\_FORMAT\_352\_B\_1 registers and compare that to the video format identified in the VD\_STD\_DS1 bits in the DATA\_FORMAT\_DS1 register. Then, make the determination of whether or not there is a mismatch on their own.

### 4.17 Signal Processing

In addition to error detection and indication, the GS1660 can also correct errors, inserting corrected code words, checksums and CRC values into the data stream.

The following processing can be performed by the GS1660:

1. TRS error correction and insertion.
2. HD line based CRC correction and insertion.
3. EDH CRC error correction and insertion.
4. HD line number error correction and insertion.



5. Illegal code re-mapping.
6. Ancillary data checksum error correction and insertion.

All of the above features are only available in SMPTE mode ( $\overline{\text{SMPTE\_BYPASS}} = \text{HIGH}$ ).

To enable these features, the IOPROC\_EN/ $\overline{\text{DIS}}$  pin must be set HIGH, and the individual feature must be enabled via bits in the IOPROC\_DISABLE register.

The IOPROC\_DISABLE register contains one bit for each processing feature allowing each one to be enabled/disabled individually.

By default (at power up or after system reset), all of the IOPROC\_DISABLE register bits are LOW, enabling all of the processing features.

To disable an individual processing feature, set the corresponding IOPROC\_DISABLE bit HIGH in the IOPROC\_DISABLE register.

**Table 4-13: IOPROC\_DISABLE Register Bits**

Processing Feature	IOPROC_DISABLE Register Bit
TRS error correction and insertion	TRS_INS
Y and C line based CRC error correction	CRC_INS
Y and C line number error correction	LNUM_INS
Ancillary data check sum correction	ANC_CHECKSUM_INSERTION
EDH CRC error correction	EDH_CRC_INS
Illegal code re-mapping	ILLEGAL_WORD_REMAP
H timing signal configuration	H_CONFIG
Update EDH Flags	EDH_FLAG_UPDATE
Ancillary Data Extraction	ANC_DATA_EXT
Regeneration of 352M packets	$\overline{\text{REGEN\_352M}}$

### 4.17.1 TRS Correction & Insertion

When TRS Error Correction and Insertion is enabled, the GS1660 generates and overwrites TRS code words as required.

TRS Word Generation and Insertion is performed using the timing generated by the Timing Signal Generator. The timing signal generator performs bit error correction on incoming FVH information based on the Hamming code information embedded in the TRS-XYZ word. This provides an element of noise immunity over using just the received TRS information.

This feature is enabled when the IOPROC\_EN/ $\overline{\text{DIS}}$  pin is HIGH and the TRS\_INS\_DISABLE bit in the IOPROC\_DISABLE register is set LOW.

**NOTE:** Inserted TRS code words are always 10-bit compliant, irrespective of the bit depth of the incoming video stream.

### 4.17.2 Line Based CRC Correction & Insertion

When CRC Error Correction and Insertion is enabled, the GS1660 generates and inserts line based CRC words into both the Y and C channels of the data stream.

Line based CRC word generation and insertion only occur in HD mode, and is enabled in when the IOPROC\_EN/ $\overline{\text{DIS}}$  pin is HIGH and the CRC\_INS\_DSX\_MASK bit in the IOPROC\_X register is set LOW.

### 4.17.3 Line Number Error Correction & Insertion

When Line Number Error Correction and Insertion is enabled, the GS1660 calculates and inserts line numbers into the output data stream. Re-calculated line numbers are inserted into both the Y and C channels.

Line number generation is in accordance with the relevant HD video standard as determined by the Automatic Standards Detection block.

This feature is enabled when the device is operating in HD mode, the IOPROC\_EN/ $\overline{\text{DIS}}$  pin is HIGH and the LNUM\_INS\_DSX\_MASK bit in the IOPROC\_X register is set LOW.

### 4.17.4 ANC Data Checksum Error Correction & Insertion

When ANC data Checksum Error Correction and Insertion is enabled, the GS1660 generates and inserts ancillary data checksums for all ancillary data words by default.

Where user specified ancillary data has been programmed (see [Section 4.16.1](#)), only the checksums for the programmed ancillary data is corrected.

This feature is enabled when the IOPROC\_EN/ $\overline{\text{DIS}}$  pin is HIGH and the ANC\_CHECKSUM\_INSERTION\_DSX\_MASK bit in the IOPROC\_X register is set LOW.

### 4.17.5 EDH CRC Correction & Insertion

When EDH CRC Error Correction and Insertion is enabled, the GS1660 generates and overwrites full field and active picture CRC check-words.

Additionally, the device sets the active picture and full field CRC 'V' bits HIGH in the EDH packet. The AP\_CRC\_V and FF\_CRC\_V register bits only report the received EDH validity flags.

EDH FF and AP CRC's are only inserted when the device is operating in SD mode, and if the EDH data packet is detected in the received video data.

Although the GS1660 modifies and inserts EDH CRC's and EDH packet checksums, EDH error flags are only updated when the EDH\_FLAG\_UPDATE\_MASK bit is LOW.

This feature is enabled in SD mode, when the IOPROC\_EN/ $\overline{\text{DIS}}$  pin is HIGH and the EDH\_CRC\_INS\_MASK bit in the IOPROC\_1 register is set LOW.

### 4.17.6 Illegal Word Re-mapping

All words within the active picture (outside the horizontal and vertical blanking periods), between the values of 3FCh and 3FFh are re-mapped to 3FBh. All words within the active picture area between the values of 000h and 003h are remapped to 004h.

This feature is enabled when the IOPROC\_EN/ $\overline{\text{DIS}}$  pin is HIGH and the ILLEGAL\_WORD\_REMAP\_DSX\_MASK bit in the IOPROC\_X register is set LOW.

### 4.17.7 TRS and Ancillary Data Preamble Remapping

8-bit TRS and ancillary data preambles are re-mapped to 10-bit values. 8-bit to 10-bit mapping of TRS headers is only supported if the TRS values are 3FC 000 000. Other values such as 3FD, 3FE, 3FF, 001, 002 and 003 are not supported. This feature is enabled by default, and can be disabled via the IOPROC\_X register.

### 4.17.8 Ancillary Data Extraction

Ancillary data may be extracted externally from the GS1660 output stream using the Y/1ANC and C/2ANC signals, and external logic.

As an alternative, the GS1660 includes a FIFO, which extracts ancillary data using read access via the host interface to ease system implementation. The FIFO stores up to 2048 x 16 bit words of ancillary data in two separate 1024 word memory banks.

The device writes the contents of ANC packets into the FIFO, starting with the first Ancillary Data Flag (ADF), followed by up to 1024 words.

All Data Identification (DID), Secondary Data Identification (SDID), Data Count (DC), user data, and checksum words are written into the device memory.

The device detects ancillary data packet DID's placed anywhere in the video data stream, including the active picture area.

Ancillary data from the Y channel or Data Stream One is placed in the Least Significant Word (LSW) of the FIFO, allocated to the lower 8 bits of each FIFO address.

Ancillary data from the C channel or Data Stream Two is placed in the Most Significant Word (MSW) (upper 8 bits) of each FIFO address.

**NOTE:** Please refer to the ANC insertion and Extraction Application Note (Doc ID: 53410), for discrete steps and example of Ancillary data extraction.

In SD mode, ancillary data is placed in the LSW of the FIFO. The MSW is set to zero.

If the ANC\_TYPE registers are all set to zero, the device extracts all types of ancillary data. If programmable ancillary data extraction is required, then up to five types of ancillary data to be extracted can be programmed in the ANC\_TYPE registers (see [Section 4.16.1](#)).

Additionally, the lines from which the packets are to be extracted can be programmed into the ANC\_LINEA[10:0] and ANC\_LINEB[10:0] registers, allowing ancillary data from a maximum of two lines per frame to be extracted. If only one line number register is programmed (with the other set to zero), ancillary data packets are extracted from one line per frame only. When both registers are set to zero, the device extracts packets from all lines.

To start Ancillary Data Extraction, the ANC\_DATA\_EXT\_MASK bit of the host interface must be set LOW. Ancillary data packet extraction begins in the following frame (see [Figure 4-21: Ancillary Data Extraction - Step A](#)).

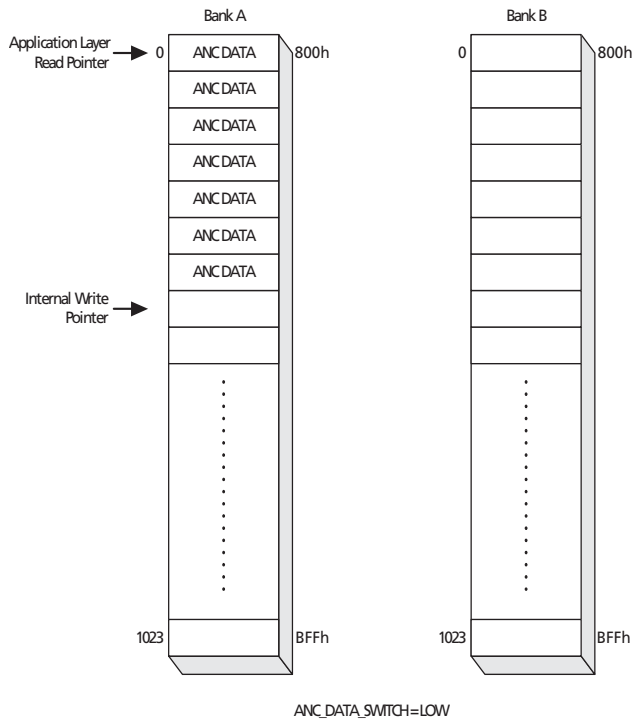

Figure 4-21: Ancillary Data Extraction - Step A

Ancillary data is written into Bank A until full. The Y/1ANC and C/2ANC output flags can be used to determine the length of the ancillary data extracted and when to begin reading the extracted data from memory.

While the `ANC_DATA_EXT_MASK` bit is set LOW, the `ANC_DATA_SWITCH` bit can be set HIGH during or after reading the extracted data. New data is then written into Bank B (up to 1024 x 16-bit words), at the corresponding host interface addresses (see [Figure 4-22: Ancillary Data Extraction - Step B](#)).

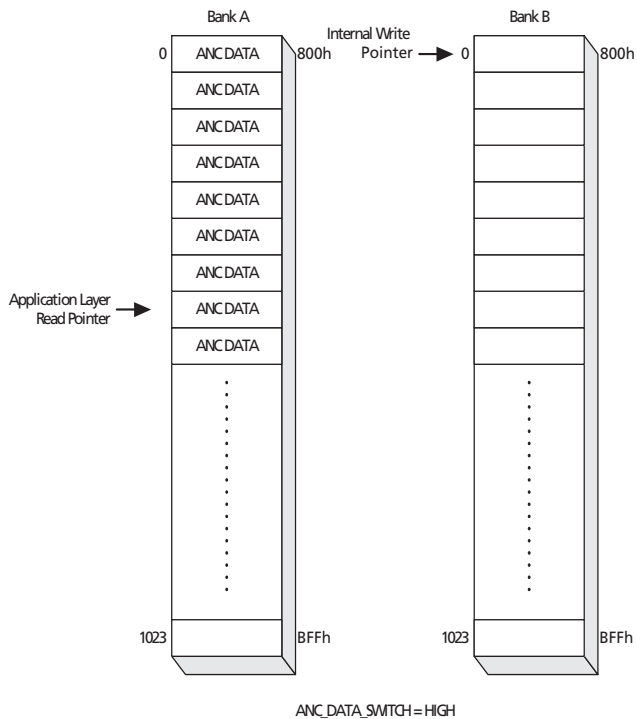

Figure 4-22: Ancillary Data Extraction - Step B

To read the new data, toggle the ANC\_DATA\_SWITCH bit LOW. The old data in Bank A is cleared to zero and extraction continues in Bank B (see [Figure 4-23: Ancillary Data Extraction - Step C](#)).

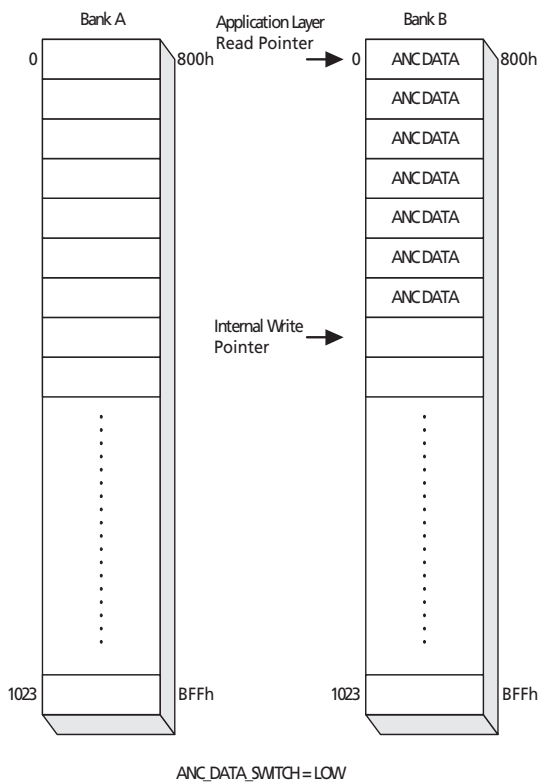

Figure 4-23: Ancillary Data Extraction - Step C

If the ANC\_DATA\_SWITCH bit is not toggled, extracted data is written into Bank B until full. To continue extraction in Bank A, the ANC\_DATA\_SWITCH bit must be toggled HIGH (see Figure 4-24: Ancillary Data Extraction - Step D).

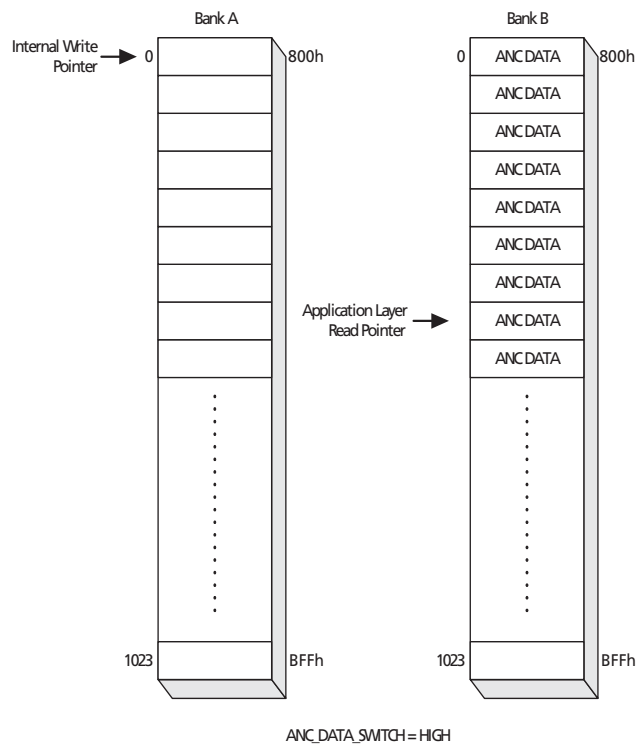

Figure 4-24: Ancillary Data Extraction - Step D

Toggling the ANC\_DATA\_SWITCH bit LOW returns the process to step A (Figure 4-21).

**NOTE 1:** Toggling the ANC\_DATA\_SWITCH must occur at a time when no extraction is taking place, i.e. when the both the Y/1ANC and C/2ANC signals are LOW.

To turn extraction off, the ANC\_DATA\_EXT\_MASK bit must be set HIGH.

In HD mode, the device can detect ancillary data packets in the Luma video data only, Chroma video data only, or both. By default (at power-up or after a system reset) the device extracts ancillary data packets from the luma channel only.

To extract packets from the Chroma channel only, the HD\_ANC\_C2 bit of the host interface must be set HIGH. To extract packets from both Luma and Chroma video data, the HD\_ANC\_Y1\_C2 bit must be set HIGH (the setting of the HD\_ANC\_C2 bit is ignored).

The default setting of both the HD\_ANC\_C2 and HD\_ANC\_Y1\_C2 is LOW. The setting of these bits is ignored when the device is configured for SD video standards.

Ancillary data packet extraction and deletion is disabled when the IOPROC\_EN/ $\overline{\text{DIS}}$  pin is set LOW.

After extraction, the ancillary data may be deleted from the video stream by setting the ANC\_DATA\_DEL bit of the host interface HIGH. When set HIGH, all existing ancillary data is removed and replaced with blanking values. If any of the ANC\_TYPE registers are programmed with a DID and/or SDID, only the ancillary data packets with the matching IDs are deleted from the video stream.

**NOTE 2:** After the ancillary data determined by the ANC\_TYPE\_X\_APX registers has been deleted, other existing ancillary data may not be contiguous. The device does not concatenate the remaining ancillary data.

**NOTE 3:** Reading extracted ancillary data from the host interface must be performed while there is a valid video signal present at the serial input and the device is locked (LOCKED signal is HIGH).

## 4.18 GSPI - HOST Interface

The GSPI, or Genum Serial Peripheral Interface, is a 4-wire interface provided to allow the system to access additional status and control information through configuration registers in the GS1660.

The GSPI is comprised of a Serial Data Input signal (SDIN), Serial Data Output signal (SDOUT), an active low Chip Select ( $\overline{CS}$ ), and a Burst Clock (SCLK).

Because these pins are shared with the JTAG interface port, an additional control signal pin JTAG/ $\overline{HOST}$  is provided.

When JTAG/ $\overline{HOST}$  is LOW, the GSPI interface is enabled. When JTAG/ $\overline{HOST}$  is HIGH, the JTAG interface is enabled.

When operating in GSPI mode, the SCLK, SDIN, and  $\overline{CS}$  signals must be provided by the system. The SDOUT pin is a non-clocked loop-through of SDIN and may be connected to the SDIN of another device, allowing multiple devices to be connected to the GSPI chain. See Section 4.18.2 for details. The interface is illustrated in the Figure 4-25 below.

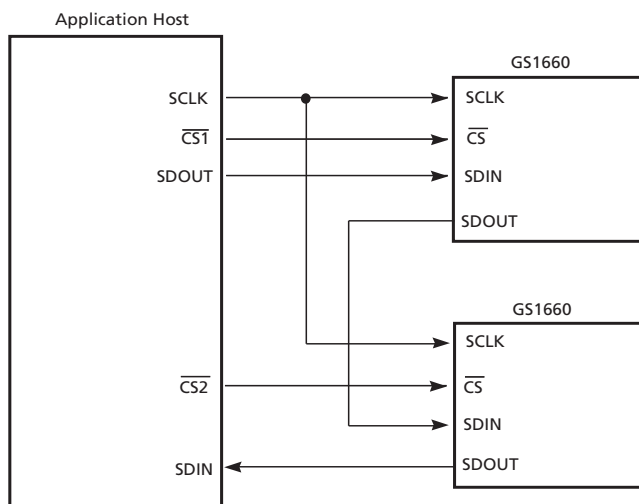

Figure 4-25: GSPI Application Interface Connection

All read or write access to the GS1660 is initiated and terminated by the system host processor. Each access always begins with a Command/Address Word, followed by a data write to, or data read from, the GS1660.

### 4.18.1 Command Word Description

The Command Word consists of a 16-bit word transmitted MSB first and contains a read/write bit, an Auto-Increment bit and a 12-bit address.

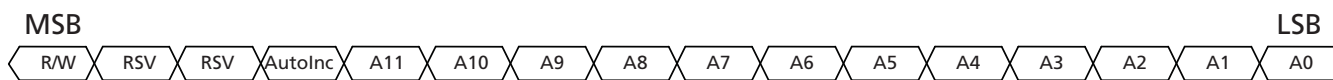

Figure 4-26: Command Word Format

Command Words are clocked into the GS1660 on the rising edge of the Serial Clock SCLK, which operates in a burst fashion. The chip select ( $\overline{CS}$ ) signal must be set low a minimum of 1.5ns ( $t_0$  in Figure 4-28) before the first clock edge to ensure proper operation.

When the Auto-Increment bit is set LOW, each Command Word must be followed by only one Data Word to ensure proper operation.

If the Auto-Increment bit is set HIGH, the following Data Word is written into the address specified in the Command Word, and subsequent Data Words are written into incremental addresses from the first Data Word. This facilitates multiple address writes without sending a Command Word for each Data Word.

**NOTE:** The RSV bits in the GSPI command word can be set to zero as placeholder, though these bits are not used.

### 4.18.2 Data Read or Write Access

During a read sequence (Command Word R/W bit set HIGH) serial data is transmitted or received MSB first, synchronous with the rising edge of the serial clock SCLK. The Chip Select ( $\overline{CS}$ ) signal must be set low a minimum of 1.5ns ( $t_0$  in Figure 4-28) before the first clock edge to ensure proper operation. The first bit (MSB) of the Serial Output (SDOUT) is available ( $t_5$  in Figure 4-29) following the last falling SCLK edge of the read Command Word, the remaining bits are clocked out on the negative edges of SCLK.

**NOTE:** When several devices are connected to the GSPI chain, only one  $\overline{CS}$  may be asserted during a read sequence.

During a write sequence (Command Word R/W bit set LOW), a wait state of 37.1ns ( $t_4$  in Figure 4-28) is required between the Command Word and the following Data Word. This wait state must also be maintained between successive Command Word/Data Word write sequences. When Auto Increment mode is selected (AutoInc = 1), the wait state must be maintained between successive Data Words after the initial Command Word/Data Word sequence.

During the write sequence, all Command and following Data Words input at the SDIN pin are output at the SDOUT pin unchanged. When several devices are connected to the GSPI chain, data can be written simultaneously to all the devices which have  $\overline{CS}$  set LOW.



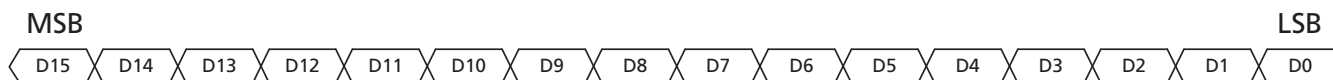

Figure 4-27: Data Word Format

### 4.18.3 4GSPi Timing

Write and Read Mode timing for the GSPi interface;

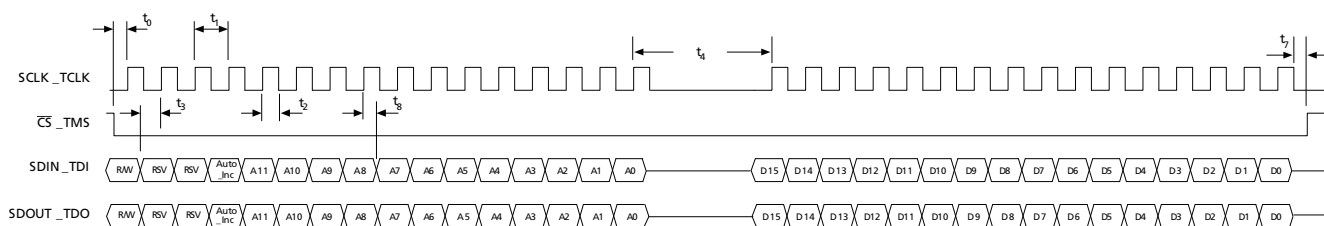

Figure 4-28: Write Mode

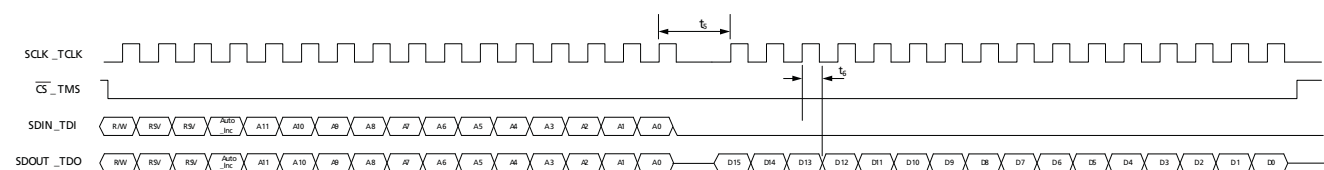

Figure 4-29: Read Mode

SDIN\_TDI to SDOUT\_TDO combinational path for daisy chain connection of multiple GS1660.

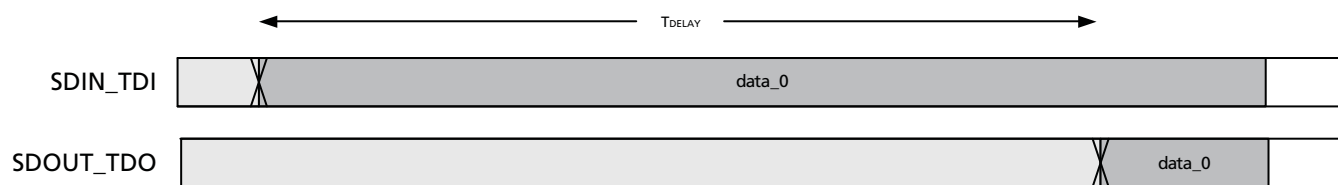

Figure 4-30: GSPi Time Delay

Table 4-14: GSPi Time Delay

Parameter	Symbol	Conditions	Min	Typ	Max	Units
Delay Time	$t_{\text{DELAY}}$	50% levels; 1.8V operation	-	-	13.1	ns
Delay Time	$t_{\text{DELAY}}$	50% levels; 3.3V operation	-	-	9.7	ns

**Table 4-15: GSPI Timing Parameters** (50% levels; 3.3V or 1.8V operation)

Parameter	Symbol	Min	Typ	Max	Units	
$\overline{CS}$ low before SCLK rising edge	$t_0$	1.5	–	–	ns	
SCLK period	$t_1$	16.67	–	–	ns	
SCLK duty cycle	$t_2$	40	50	60	%	
Input data setup time	$t_3$	1.5	–	–	ns	
Time between end of Command Word (or data in Auto-Increment mode) and the first SCLK of the following Data Word – write cycle	$t_4$	PCLK (MHz)	ns	–	–	ns
		unlocked	100	–	–	ns
		27.0	37.1	–	–	ns
		74.25	13.5	–	–	ns
		148.5	6.7	–	–	ns
Time between end of Command Word (or data in Auto-Increment mode) and the first SCLK of the following Data Word – read cycle.	$t_5$	PCLK (MHz)	ns	–	–	ns
		unlocked	–	–	–	ns
		27.0	148.4	–	–	ns
		74.25	53.9	–	–	ns
		148.5	27	–	–	ns
Time between end of Command Word (or data in Auto-Increment mode) and the first SCLK of the following Data Word – read cycle - ANC FIFO Read	$t_5$	222.6	–	–	ns	
Output hold time (15pF load)	$t_6$	1.5	–	–	ns	
$\overline{CS}$ high after last SCLK rising edge	$t_7$	PCLK (MHz)	ns	–	–	ns
		unlocked	445	–	–	ns
		27.0	37.1	–	–	ns
		74.25	13.5	–	–	ns
		148.5	6.7	–	–	ns
Input data hold time	$t_8$	1.5	–	–	ns	

This timing must be satisfied across all ambient temperature and power supply operating conditions, as described in the [Electrical Characteristics on page 14](#).

## 4.19 Host Interface Register Maps

Table 4-16: Configuration and Status Registers

Address	Register Name	Bit Name	Bit	Description	R/W	Default
000h	IOPROC_1	RSVD	15	Reserved.	R	0
		TRS_WORD_REMAP_DS1_DISABLE	14	Disables 8-bit TRS word remapping for HD and SD inputs.	R/W	0
		RSVD	13	Reserved.	R/W	0
		EDH_FLAG_UPDATE_MASK	12	Disables updating of EDH error flags.	R/W	0
		EDH_CRC_INS_MASK	11	Disables EDH_CRC error correction and insertion.	R/W	0
		H_CONFIG	10	Selects the H blanking indication: 0: Active line blanking - the H output is HIGH for all the horizontal blanking period, including the EAV and SAV TRS words. 1: TRS based blanking - the H output is set HIGH for the entire horizontal blanking period as indicated by the H bit in the received TRS signals. This signal is only valid when TIM_861 is set to '0' (via pin or host interface).	R/W	0
		ANC_DATA_EXT_MASK	9	Disables ancillary data extraction FIFO.	R/W	0
		RSVD	8	Reserved.	R/W	0
		TIM_861_PIN_DISABLE	7	Disable TIM_861 pin control when set to '1', and use TIMING_861 bit instead.	R/W	0
		TIMING_861	6	Selects the output timing reference format: 0 = Digital FVH timing output; 1 = CEA-861 timing output.	R/W	0
		RSVD	5	Reserved.	R/W	0
		ILLEGAL_WORD_REMAP_DS1_MASK	4	Disables illegal word remapping for HD and SD inputs.	R/W	0
		ANC_CHECKSUM_INSERTION_DS1_MASK	3	Disables insertion of ancillary data checksums for HD and SD inputs.	R/W	0
		CRC_INS_DS1_MASK	2	Disables insertion of HD CRC words for HD inputs.	R/W	0
		000h	IOPROC_1	LNUM_INS_DS1_MASK	1	Disables insertion of line numbers for HD inputs.
TRS_INS_DS1_MASK	0			Disables insertion of TRS words for HD and SD inputs.	R/W	0
001h	RSVD	RSVD	15-0	Reserved.	R/W	N/A

**Table 4-16: Configuration and Status Registers (Continued)**

Address	Register Name	Bit Name	Bit	Description	R/W	Default
002h	ERROR_STAT_1	RSVD	15-11	Reserved.	ROCW	0
		VD_STD_ERR_DS1	10	Video Standard Error indication for HD and SD inputs.	ROCW	0
		FF_CRC_ERR	9	EDH Full Frame CRC error indication.	ROCW	0
		AP_CRC_ERR	8	EDH Active Picture CRC error indication.	ROCW	0
		RSVD	7	Reserved.	ROCW	0
		CCS_ERR_DS1	6	Chroma ancillary data checksum error indication for HD and SD inputs.	ROCW	0
		YCS_ERR_DS1	5	Luma ancillary data checksum error indication for HD and SD inputs.	ROCW	0
		CCRC_ERR_DS1	4	Chroma CRC error indication for HD inputs.	ROCW	0
		YCRC_ERR_DS1	3	Luma CRC error indication for HD inputs.	ROCW	0
		LNUM_ERR_DS1	2	Line number error indication for HD inputs.	ROCW	0
		SAV_ERR_DS1	1	SAV error indication for HD and SD inputs.	ROCW	0
		EAV_ERR_DS1	0	EAV error indication for HD and SD inputs.	ROCW	0
003h	RSVD	RSVD	15-0	Reserved.	ROCW	N/A

**Table 4-16: Configuration and Status Registers (Continued)**

Address	Register Name	Bit Name	Bit	Description	R/W	Default
004h	EDH_FLAG_IN	EDH_DETECT	15	Embedded EDH packet detected.	RO	0
		ANC_UES_IN	14	Ancillary data – unknown error status flag.	RO	0
		ANC_IDA_IN	13	Ancillary data – internal error detected already flag.	RO	0
		ANC_IDH_IN	12	Ancillary data – internal error detected here flag	RO	0
		ANC_EDA_IN	11	Ancillary data – error detected already flag.	RO	0
		ANC_EDH_IN	10	Ancillary data – error detected here flag.	RO	0
		FF_UES_IN	9	EDH Full Field – unknown error status flag.	RO	0
		FF_IDA_IN	8	EDH Full Field – internal error detected already flag.	RO	0
		FF_IDH_IN	7	EDH Full Field – internal error detected here flag.	RO	0
		FF_EDA_IN	6	EDH Full Field – error detected already flag.	RO	0
		FF_EDH_IN	5	EDH Full Field – error detected here flag.	RO	0
		AP_UES_IN	4	EDH Active Picture – unknown error status flag.	RO	0
		AP_IDA_IN	3	EDH Active Picture – internal error detected already flag.	RO	0
		AP_IDH_IN	2	EDH Active Picture – internal error detected here flag.	RO	0
		AP_EDA_IN	1	EDH Active Picture – error detected already flag.	RO	0
		AP_EDH_IN	0	EDH Active Picture – error detected here flag.	RO	0

**Table 4-16: Configuration and Status Registers (Continued)**

Address	Register Name	Bit Name	Bit	Description	R/W	Default
005h	EDH_FLAG_OUT	RSVD	15	Reserved.	RO	0
		ANC_UES	14	Ancillary data – Unknown Error Status flag.	RO	1
		ANC_IDA	13	Ancillary data – Internal error Detected Already flag.	RO	0
		ANC_IDH	12	Ancillary data – Internal error Detected Here flag.	RO	0
		ANC_EDA	11	Ancillary data – Error Detected Already flag.	RO	0
		ANC_EDH	10	Ancillary data – Error Detected Here flag.	RO	0
		FF_UES	9	EDH Full Field – Unknown Error Status flag.	RO	1
		FF_IDA	8	EDH Full Field – Internal error Detected Already flag.	RO	0
		FF_IDH	7	EDH Full Field – Internal error Detected Here flag.	RO	0
		FF_EDA	6	EDH Full Field – Error Detected Already flag.	RO	0
		FF_EDH	5	EDH Full Field – Error Detected Here flag.	RO	0
		AP_UES	4	EDH Active Picture – Unknown Error Status flag.	RO	1
		AP_IDA	3	EDH Active Picture – Internal error Detected Already flag.	RO	0
		AP_IDH	2	EDH Active Picture – Internal error Detected Here flag.	RO	0
		AP_EDA	1	EDH Active Picture – Error Detected Already flag.	RO	0
		AP_EDH	0	EDH Active Picture – Error Detected Here flag.	RO	0
006h	DATA_FORMAT_DS1	FF_CRC_V	15	EDH Full Field CRC Validity bit.	RO	0
		AP_CRC_V	14	EDH Active Picture CRC Validity bit.	RO	0
		VD_STD_DS1	13-8	Detected Video Standard for HD and SD inputs.	RO	29
		CDATA_FORMAT_DS1	7-4	Data format as indicated in Chroma channel for HD and SD inputs.	RO	15
		YDATA_FORMAT_DS1	3-0	Data format as indicated in Luma channel for HD and SD inputs.	RO	15
007h	RSVD	RSVD	15-0	Reserved.	RO	N/A

**Table 4-16: Configuration and Status Registers (Continued)**

Address	Register Name	Bit Name	Bit	Description	R/W	Default
008h	IO_CONFIG	RSVD	15	Reserved.	RW	0
		STAT2_CONFIG	14-10	Configure STAT2 output pin: 00000: H Blanking when TIM_861 = 0; HSYNC when TIM_861 = 1 00001: V Blanking when TIM_861 = 0; VSYNC when TIM_861 = 1 00010: F bit when TIM_861 = 0; Data Enable (DE) when TIM_861 = 1 00011: LOCKED 00100: Y/1ANC: ANC indication (SD), Luma ANC indication (HD) 00101: C/2ANC: Chroma ANC indication (HD) 00110: Data Error 00111: Video Error 01000: Reserved 01001: EDH Detected 01010: Carrier Detect 01011: RATE_DET 01100 - 11111: Reserved	RW	2
		STAT1_CONFIG	9-5	Configure STAT1 output pin. (Refer to above for decoding)	RW	1
		STAT0_CONFIG	4-0	Configure STAT0 output pin. (Refer to above for decoding)	RW	0
009h	IO_CONFIG2	RSVD	15	Reserved.	RW	0
		STAT5_CONFIG	14-10	Configure STAT5 output pin. (Refer to above for decoding)	RW	6
		STAT4_CONFIG	9-5	Configure STAT4 output pin. (Refer to above for decoding)	RW	4
		STAT3_CONFIG	4-0	Configure STAT3 output pin. (Refer to above for decoding)	RW	3
00Ah	ANC_CONTROL	RSVD	15-4	Reserved.	RW	0
		ANC_DATA_SWITCH	3	Switches between FIFO memories.	RW	0
		ANC_DATA_DEL	2	Remove Ancillary Data from output video stream, set to Luma and Chroma blanking values.	RW	0
		HD_ANC_Y1_C2	1	Extract Ancillary data from Luma and Chroma channels (HD inputs)	RW	0
		HD_ANC_C2	0	Extract Ancillary data only from Chroma channel (HD inputs)	RW	0
00Bh	ANC_LINE_A	RSVD	15-11	Reserved.	R/W	0
		ANC_LINE_A	10-0	Video Line to extract Ancillary data from.	R/W	0
00Ch	ANC_LINE_B	RSVD	15-11	Reserved.	R/W	0
		ANC_LINE_B	10-0	Second video Line to extract Ancillary data from.	R/W	0

**Table 4-16: Configuration and Status Registers (Continued)**

Address	Register Name	Bit Name	Bit	Description	R/W	Default
00Dh - 00Eh	RSVD	RSVD	15-0	Reserved.	RO	N/A
00Fh	ANC_TYPE_1_AP 1	ANC_TYPE1_DS1	15-0	Programmable DID/SDID pair #1 to extract from HD and SD input formats ([15:8] = DID, [7:0] = SDID).	R/W	0
010h	ANC_TYPE_2_AP 1	ANC_TYPE2_DS1	15-0	Programmable DID/SDID pair #2 to extract from HD and SD input formats ([15:8] = DID, [7:0] = SDID).	R/W	0
011h	ANC_TYPE_3 _AP1	ANC_TYPE3_DS1	15-0	Programmable DID/SDID pair #3 to extract from HD and SD input formats ([15:8] = DID, [7:0] = SDID).	R/W	0
012h	ANC_TYPE_4 _AP1	ANC_TYPE4_DS1	15-0	Programmable DID/SDID pair #4 to extract from HD and SD input formats ([15:8] = DID, [7:0] = SDID).	R/W	0
013h	ANC_TYPE_5 _AP1	ANC_TYPE5_DS1	15-0	Programmable DID/SDID pair #5 to extract from HD and SD input formats ([15:8] = DID, [7:0] = SDID).	R/W	0
014h - 018h	RSVD	RSVD	15-0	Reserved.	RO	N/A
019h	VIDEO_FORMAT _352_A_1	VIDEO_FORMAT_2_DS1	15-8	SMPTE 352M embedded packet – byte 2.	R	0
		VIDEO_FORMAT_1_DS1	7-0	SMPTE 352M embedded packet – byte 1: [7]: Version identifier [6:0]: Video Payload Identifier.	R	0
01Ah	VIDEO_FORMAT _352_B_1	VIDEO_FORMAT_4_DS1	15-8	SMPTE 352M embedded packet – byte 4.	R	0
		VIDEO_FORMAT_3_DS1	7-0	SMPTE 352M embedded packet – byte 3.	R	0
01Bh - 01Eh	RSVD	RSVD	15-0	Reserved.	R	N/A
01Fh	RASTER_STRUC_ 1	RSVD	15-14	Reserved.	R	0
		WORDS_PER_ACTLINE	13-0	Words Per Active Line.	R	0
020h	RASTER_STRUC_ 2	RSVD	15-14	Reserved.	R	0
		WORDS_PER_LINE	13-0	Total Words Per Line.	R	0
021h	RASTER_STRUC_ 3	RSVD	15-11	Reserved.	R	0
		LINES_PER_FRAME	10-0	Total Lines Per Frame.	R	0



**Table 4-16: Configuration and Status Registers (Continued)**

Address	Register Name	Bit Name	Bit	Description	R/W	Default	
022h	RASTER_STRUC_4	RATE_SEL_READBACK	15-14	Read back detected data rate: 0 = HD, 1,3=SD, 2=Reserved	R	0	
		M	13	Specifies detected M value 0: 1.000 1: 1.001	R	0	
		<p><b>Note:</b> In certain systems, due to the greater ppm offsets in the crystal, the 'M' bit may not assert properly. In such cases, bits 3:0 in Register 06Fh can be increased to a maximum value of 4.</p>					
		STD_LOCK	12	Video standard lock.	R	0	
		INT_PROG	11	Interlaced or progressive.	R	0	
023h	FLYWHEEL_STATUS	ACTLINE_PER_FIELD	10-0	Active lines per frame.	R	0	
		RSVD	15-2	Reserved.	R	0	
		V_LOCK_DS1	1	Indicates that the timing signal generator is locked to vertical timing (HD and SD inputs).	R	0	
024h	RATE_SEL	H_LOCK_DS1	0	Indicates that the timing signal generator is locked to horizontal timing (HD and SD inputs).	R	0	
		RSVD	15-3	Reserved.	R	0	
		AUTO/MAN	2	Detect data rate automatically (1) or program manually (0).	R/W	1	
025h	TIM_861_FORMAT	RATE_SEL_TOP	1-0	Programmable rate select in manual mode: 0 = HD, 1,3=SD, 2=Reserved	R/W	0	
		RSVD	15-7	Reserved.	R	0	
		FORMAT_ERR	6	Indicates standard is not recognized for CEA 861 conversion.	R	1	
026h	TIM_861_CFG	FORMAT_ID_861	5-0	CEA-861 format ID of input video stream. Refer to <a href="#">Table 4-9</a> .	R	0	
		RSVD	15-3	Reserved.	R	0	
		VSYNC_INVERT	2	Invert output VSYNC pulse.	R/W	0	
027h - 036h	RSVD	HSYNC_INVERT	1	Invert output HSYNC pulse.	R/W	0	
		TRS_861	0	Sets the timing reference outputs to DFP timing mode when set to '1'. By default, the timing reference outputs follow CEA-861 timing mode. Only valid when TIM_861 is set to '1'.	R/W	0	
		RSVD	15-0	Reserved.	R	0	

**Table 4-16: Configuration and Status Registers (Continued)**

Address	Register Name	Bit Name	Bit	Description	R/W	Default
037h	ERROR_MASK_1	RSVD	15-11	Reserved.	R	0
		ERROR_MASK_1	10-0	Error mask for global error vector (HD, SD): bit[0]: EAV_ERR_DS1 mask bit[1]: SAV_ERR_DS1 mask bit[2]: LNUM_ERR_DS1 mask bit[3]: YCRC_ERR_DS1 mask bit[4]: CCRC_ERR_DS1 mask bit[5]: YCS_ERR_DS1 mask bit[6]: CCS_ERR_DS1 mask bit[7]: Reserved bit[8]: AP_CRC_ERR mask bit[9]: FF_CRC_ERR mask bit[10]: VD_STD_ERR_DS1 mask	R/W	0
038h-6Bh	RSVD	RSVD	15-0	Reserved.	R	N/A
06Ch	CLK_GEN	RSVD	15-5	Reserved.	R/W	N/A
		DEL_LINE_OFFSET	4-0	Controls the offset for the delay line.	R/W	0
06Dh	IO_DRIVE_STRENGTH	RSVD	15-6	Reserved.	R/W	0
		IO_DS_CTRL_DOUT_MSB	5-4	Drive strength adjustment for DOUT[19:10] outputs and PCLK output: 00: 4mA; 01: 8mA; 10: 10mA(1.8V), 12mA(3.3V); 11: 12mA(1.8V), 16mA(3.3V)	R/W	2
		IO_DS_CTRL_STAT	3-2	Drive strength adjustment for STAT[5:0] outputs: 00: 4mA; 01: 6mA; 10: 8mA(1.8V), 10mA(3.3V); 11: 10mA(1.8V), 12mA(3.3V)	R/W	2
		IO_DS_CTRL_DOUT_LSB	1-0	Drive strength adjustment for DOUT[9:0] outputs: 00: 4mA; 01: 6mA; 10: 8mA(1.8V), 10mA(3.3V); 11: 10mA(1.8V), 12mA(3.3V)	R/W	3
06Eh	RSVD	RSVD	15-0	Reserved.	R/W	0
06Fh	RSVD	RSVD	15-4	Reserved.	R/W	0
	M_DETECTION_TOLERANCE	M_DETECTION_TOLERANCE	3-0	Sets the detection tolerance.	R/W	2
070h-085h	RSVD	RSVD	15-0	Reserved.	R/W	0

**Table 4-17: ANC Extraction FIFO Access Registers**

Address	Register Name	Bit	Description	R/W	Default
800h - BFFh	ANC_PACKET_BANK	15-0	Extracted Ancillary Data 91024 words. Bit 15-8: Most Significant Word (MSW). Bit 7-0: Least Significant Word (LSW). See <a href="#">Section 4.17.8</a> .	R	0

## 4.20 JTAG Test Operation

When the  $\overline{\text{JTAG\_HOST}}$  pin of the GS1660 is set HIGH, the host interface port is configured for JTAG test operation. In this mode, pins E7, F8, F7, and E8 become TDO, TCK, TMS, and TDI. In addition, the  $\overline{\text{RESET\_TRST}}$  pin operates as the test reset pin.

Boundary scan testing using the JTAG interface is enabled in this mode.

There are two ways in which JTAG can be used:

1. As a stand-alone JTAG interface to be used at in-circuit ATE (Automatic Test Equipment) during PCB assembly.
2. Under control of a host processor for applications such as system power on self tests.

When the JTAG tests are applied by ATE, care must be taken to disable any other devices driving the digital I/O pins. If the tests are to be applied only at ATE, this can be accomplished with tri-state buffers used in conjunction with the  $\overline{\text{JTAG\_HOST}}$  input signal. This is shown in [Figure 4-31](#).

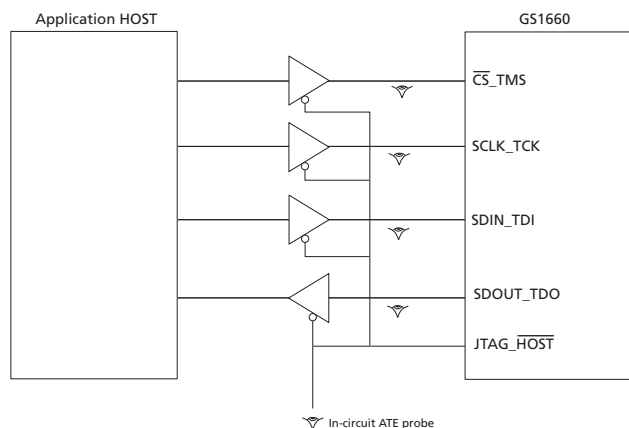

**Figure 4-31: In-Circuit JTAG**

Alternatively, if the test capabilities are to be used in the system, the host processor may still control the  $\overline{\text{JTAG\_HOST}}$  input signal, but some means for tri-stating the host must exist in order to use the interface at ATE. This is represented in [Figure 4-32](#).

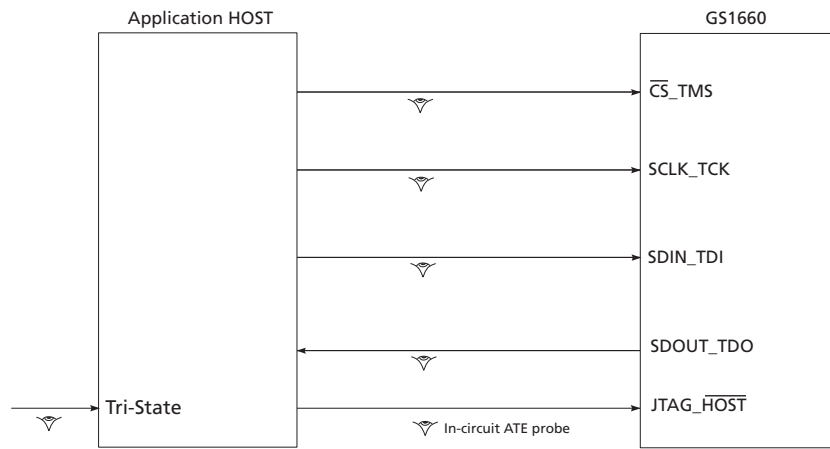

Figure 4-32: System JTAG

Scan coverage is limited to digital pins only. There is no scan coverage for analog pins VCO, SDO/ $\overline{\text{SDO}}$ , RSET, LF, and CP\_RES.

The JTAG/ $\overline{\text{HOST}}$  pin must be held LOW during scan and therefore has no scan coverage.

Please contact your Semtech representative to obtain the BSDL model for the GS1660.

## 4.21 Device Power-up

Because the GS1660 is designed to operate in a multi-voltage environment, any power-up sequence is allowed. The charge pump, phase detector, core logic, serial digital output and I/O buffers can all be powered up in any order.

## 4.22 Device Reset

**NOTE:** At power-up, the device must be reset to operate correctly.

In order to initialize all internal operating conditions to their default states, hold the  $\overline{\text{RESET\_TRST}}$  signal LOW for a minimum of  $t_{\text{reset}} = 10\text{ms}$  after all power supplies are stable. There are no requirements for power supply sequencing.

When held in reset, all device outputs are driven to a high-impedance state.

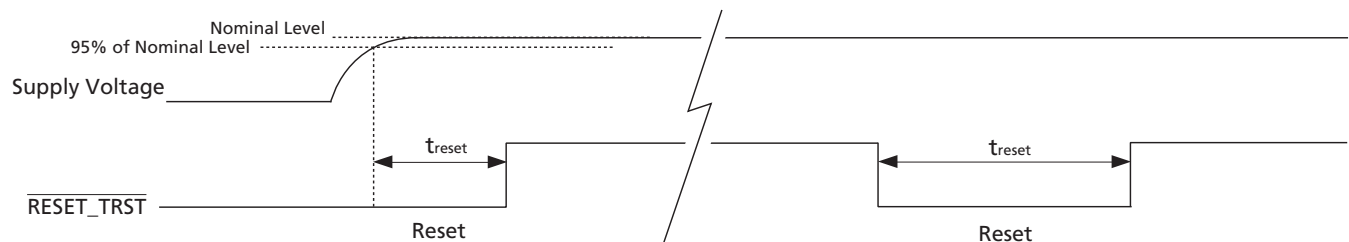

Figure 4-33: Reset Pulse

## 4.23 Standby Mode

The STANDBY pin reduces power to a minimum by disabling all circuits except for the register configuration. Upon removal of the signal to the STANDBY pin, the device returns to its previous operating condition within 1 second, without requiring input from the host interface.

# 5. Application Reference Design

## 5.1 Typical Application Circuit

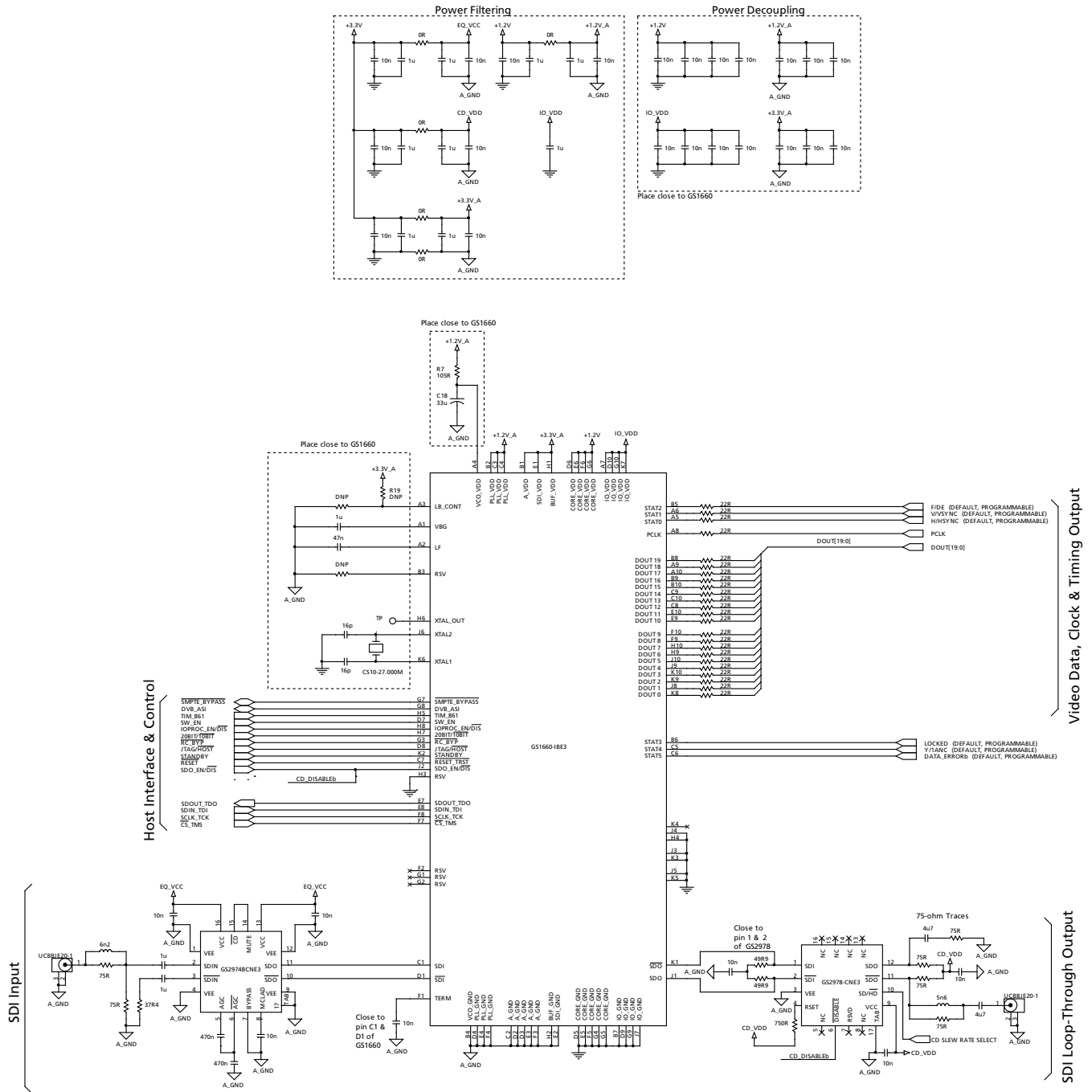

- Notes:**
1. The value of the series resistors on video data, clock, and timing connections should be determined by board signal integrity test.
  2. For analog power and ground isolation refer to PCB layout guide.
  3. For impedance controlled signal layout refer to PCB layout guide.

## 6. References & Relevant Standards

SMPTE 125M	Component video signal 4:2:2 – bit parallel interface
SMPTE 259M	10-bit 4:2:2 Component and 4fsc Composite Digital Signals - Serial Digital Interface
SMPTE 260M	1125 / 60 high definition production system – digital representation and bit parallel interface
SMPTE 267M	Bit parallel digital interface – component video signal 4:2:2 16 x 9 aspect ratio
SMPTE 274M	1920 x 1080 scanning analog and parallel digital interfaces for multiple picture rates
SMPTE 291M	Ancillary Data Packet and Space Formatting
SMPTE 292	Bit-Serial Digital Interface for High-Definition Television Systems
SMPTE 293M	720 x 483 active line at 59.94Hz progressive scan production – digital representation
SMPTE 296M	1280 x 720 scanning, analog and digital representation and analog interface
SMPTE 352M	Video Payload Identification for Digital Television Interfaces
SMPTE RP165	Error Detection Checkwords and Status Flags for Use in Bit-Serial Digital Interfaces for Television
SMPTE RP168	Definition of Vertical Interval Switching Point for Synchronous Video Switching

# 7. Package & Ordering Information

## 7.1 Package Dimensions

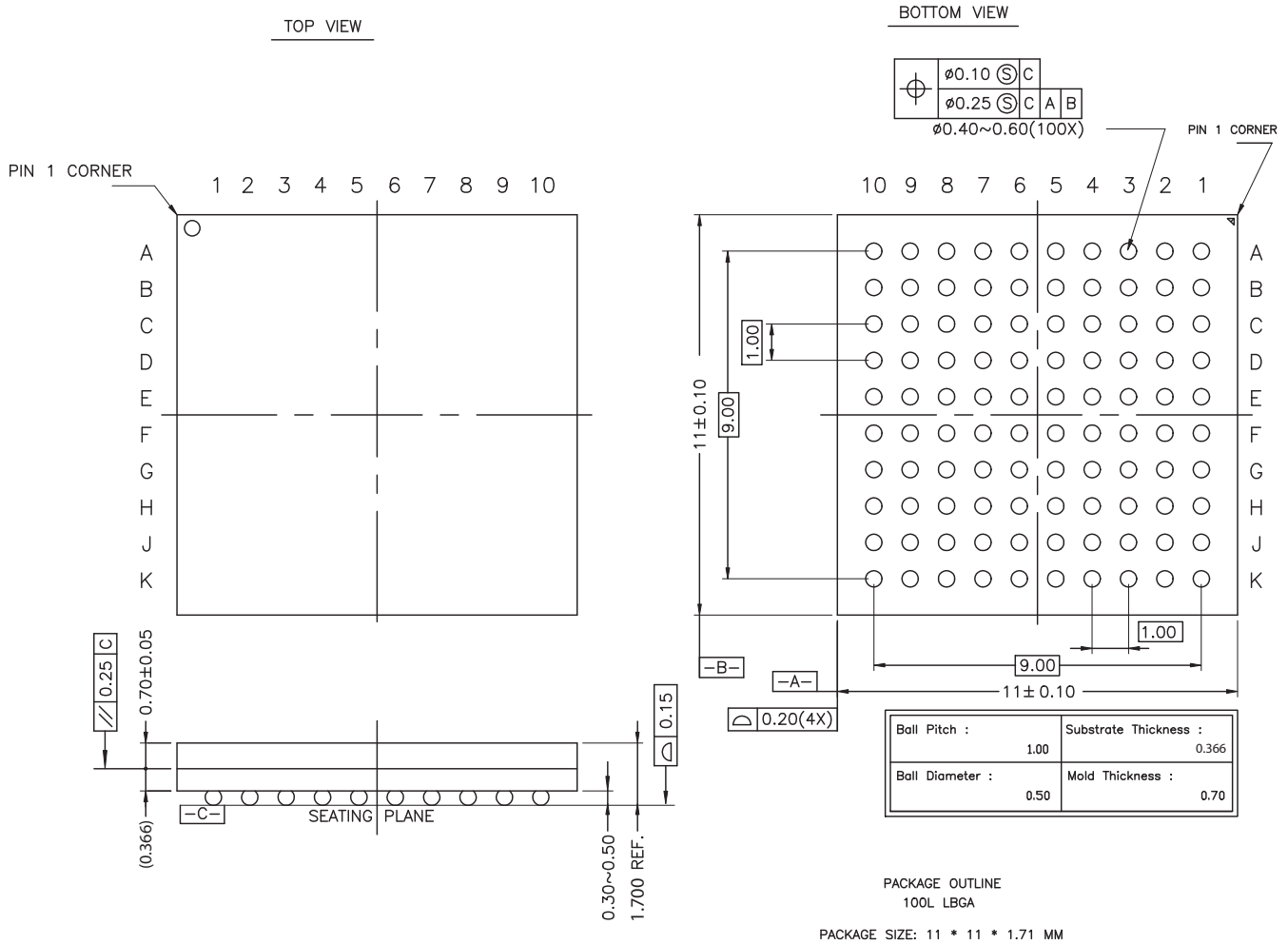

\* THE BALL DIAMETER, BALL PITCH, STAND-OFF & PACKAGE THICKNESS ARE DIFFERENT FROM JEDEC SPEC M0192 (LOW PROFILE BGA FAMILY)

## 7.2 Packaging Data

Table 7-1: Packaging Data

Parameter	Value
Package Type	11mm x 11mm 100-ball LBGA
Package Drawing Reference	JEDEC M0192 (with exceptions noted in <a href="#">Package Dimensions on page 79</a> ).
Moisture Sensitivity Level	3
Junction to Case Thermal Resistance, $\theta_{j-c}$	15.4°C/W
Junction to Air Thermal Resistance, $\theta_{j-a}$ (at zero airflow)	37.1°C/W
Junction to Board Thermal Resistance, $\theta_{j-b}$	26.4°C/W
Psi, $\psi$	0.4°C/W
Pb-free and RoHS Compliant	Yes

## 7.3 Marking Diagram

Pin 1 Indicator

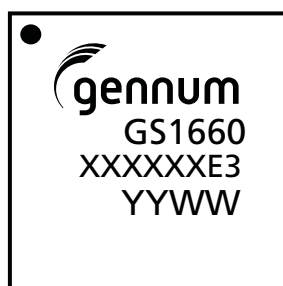

XXXXXX - Last 6 digits (excluding decimal) of SAP Batch Assembly (FIN) as listed on Packing Slip  
 E3 - Pb-free & Green indicator  
 YYWW - Date Code



## 7.4 Solder Reflow Profiles

The GS1660 is available in a Pb-free package. It is recommended that the Pb-free package be soldered with Pb-free paste using the reflow profile shown in Figure 7-1.

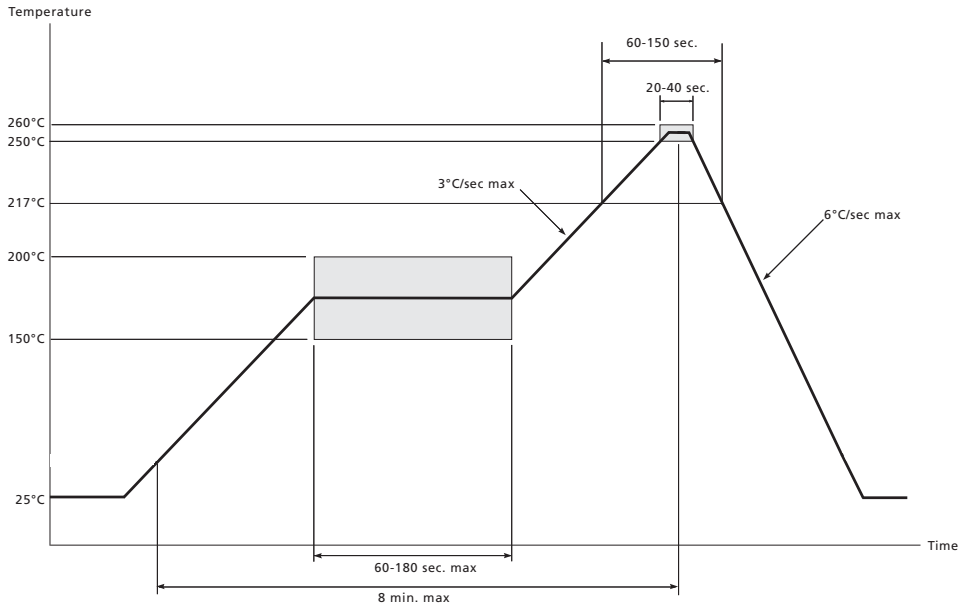

Figure 7-1: Pb-free Solder Reflow Profile

## 7.5 Ordering Information

Part Number	Package	Pb-free	Temperature Range
GS1660-IBE3	100-ball BGA	Yes	-20°C to 85°C



---

**DOCUMENT IDENTIFICATION  
DATA SHEET**

Information relating to this product and the application or design described herein is believed to be reliable, however such information is provided as a guide only and Semtech assumes no liability for any errors in this document, or for the application or design described herein. Semtech reserves the right to make changes to the product or this document at any time without notice.

**CAUTION**

ELECTROSTATIC SENSITIVE DEVICES  
DO NOT OPEN PACKAGES OR HANDLE EXCEPT AT A  
STATIC-FREE WORKSTATION



---

© Semtech 2012

All rights reserved. Reproduction in whole or in part is prohibited without the prior written consent of the copyright owner. The information presented in this document does not form part of any quotation or contract, is believed to be accurate and reliable and may be changed without notice. No liability will be accepted by the publisher for any consequence of its use. Publication thereof does not convey nor imply any license under patent or other industrial or intellectual property rights. Semtech assumes no responsibility or liability whatsoever for any failure or unexpected operation resulting from misuse, neglect improper installation, repair or improper handling or unusual physical or electrical stress including, but not limited to, exposure to parameters beyond the specified maximum ratings or operation outside the specified range.

SEMTECH PRODUCTS ARE NOT DESIGNED, INTENDED, AUTHORIZED OR WARRANTED TO BE SUITABLE FOR USE IN LIFE-SUPPORT APPLICATIONS, DEVICES OR SYSTEMS OR OTHER CRITICAL APPLICATIONS. INCLUSION OF SEMTECH PRODUCTS IN SUCH APPLICATIONS IS UNDERSTOOD TO BE UNDERTAKEN SOLELY AT THE CUSTOMER'S OWN RISK. Should a customer purchase or use Semtech products for any such unauthorized application, the customer shall indemnify and hold Semtech and its officers, employees, subsidiaries, affiliates, and distributors harmless against all claims, costs damages and attorney fees which could arise.

Notice: All referenced brands, product names, service names and trademarks are the property of their respective owners.

---

**Contact Information**

Semtech Corporation  
Gennum Products Division  
200 Flynn Road, Camarillo, CA 93012  
Phone: (805) 498-2111, Fax: (805) 498-3804  
[www.semtech.com](http://www.semtech.com)



## Стандарт Электрон Связь

Мы молодая и активно развивающаяся компания в области поставок электронных компонентов. Мы поставляем электронные компоненты отечественного и импортного производства напрямую от производителей и с крупнейших складов мира.

Благодаря сотрудничеству с мировыми поставщиками мы осуществляем комплексные и плановые поставки широчайшего спектра электронных компонентов.

Собственная эффективная логистика и склад в обеспечивает надежную поставку продукции в точно указанные сроки по всей России.

Мы осуществляем техническую поддержку нашим клиентам и предпродажную проверку качества продукции. На все поставляемые продукты мы предоставляем гарантию .

Осуществляем поставки продукции под контролем ВП МО РФ на предприятия военно-промышленного комплекса России , а также работаем в рамках 275 ФЗ с открытием отдельных счетов в уполномоченном банке. Система менеджмента качества компании соответствует требованиям ГОСТ ISO 9001.

Минимальные сроки поставки, гибкие цены, неограниченный ассортимент и индивидуальный подход к клиентам являются основой для выстраивания долгосрочного и эффективного сотрудничества с предприятиями радиоэлектронной промышленности, предприятиями ВПК и научно-исследовательскими институтами России.

С нами вы становитесь еще успешнее!

### Наши контакты:

**Телефон:** +7 812 627 14 35

**Электронная почта:** [sales@st-electron.ru](mailto:sales@st-electron.ru)

**Адрес:** 198099, Санкт-Петербург,  
Промышленная ул, дом № 19, литера Н,  
помещение 100-Н Офис 331