

NB3x6x1xxG16QFNEVK

NB3x6x1xxG16QFN OmniClock Evaluation Kit Manual



ON Semiconductor®

www.onsemi.com

EVAL BOARD USER'S MANUAL

Devices Supported

- NB3H63143G (QFN16)
- NB3V63143G (QFN16)

Introduction

The NB3x6x1xxG, which is a member of the OmniClock family, is a versatile user programmable clock generator designed by ON Semiconductor with customer experience in mind. These devices are tailored to fit in to an extensive array of applications including wearable technology, smart phones, digital cameras, E-books, portable electronics, and Internet of Things. The NB3H designated parts are powered by 3.3 V and 2.5 V supplies while NB3V parts support 1.8 V operation.

These devices are One Time Programmable (OTP), low power PLL based clock generators that accept fundamental mode parallel resonant crystals of up to 50 MHz or a single ended LVCMOS/LVTTL reference clock input of up to 200 MHz. The outputs can be configured as either three single ended LVCMOS/LVTTL outputs or a combination of one single ended output and one differential LVPECL/LVDS/HCSL/CML output. The generated clock output's frequency can range between 8 kHz to 200 MHz.

Other programmable parameters include internal crystal load capacitor, drive strength for LVCMOS outputs, output frequency modulation controls (type, depth, modulation rate), output phase inversion, and PLL bypass mode. The devices are fully functional between -40°C to $+85^{\circ}\text{C}$.

Description

NB3x6x1xxG16QFNEVK is an evaluation kit offering a convenient solution for evaluating QFN16 devices. Included are one main board, a daughter board, and a USB cable. The main board and daughter board are 4 layer boards with dedicated power and GND planes.

The daughter board plugs directly on to the main board using four 4-pin header connectors. These connectors route the signal, power and ground to the device on the daughter board. The two boards correctly plug into one another in only one orientation ensuring proper pin alignment. The daughter board has a 16QFN socket to test NB3x6x1xxG devices. A view of the main board with the 16QFN daughter board is shown in Figure 1 and 2.

The Clock Cruiser Software is the GUI software developed to be used with this evaluation kit, and can be downloaded for free from www.onsemi.com. It allows the user to set programmable parameters and generate solutions that fit application needs. These solutions can then be programmed in to device's OTP memory or be temporarily written into device registers for evaluation. For more information on using the GUI, refer to Clock Cruiser User Guide.

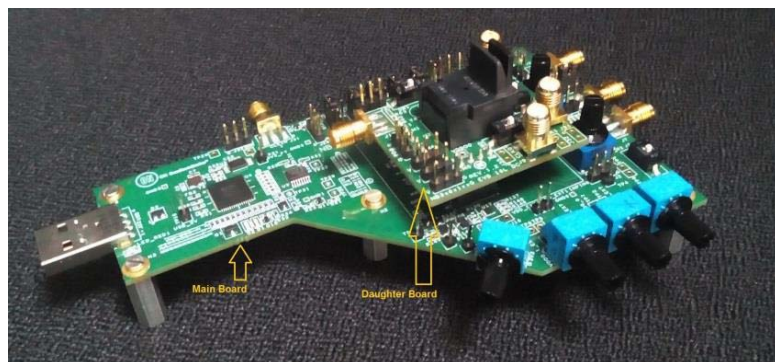

Figure 1. 45° View of Main Board with 16QFN Daughter Board

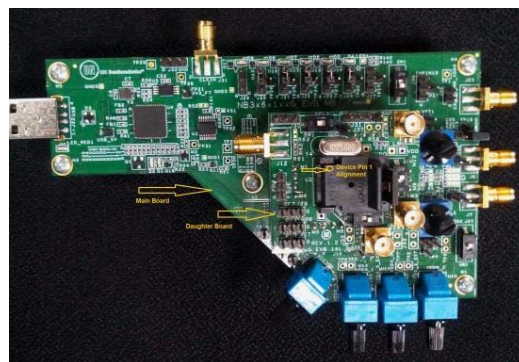

Figure 2. Top View of Main Board with 16QFN Daughter Board

NB3x6x1xxG16QFNEVK

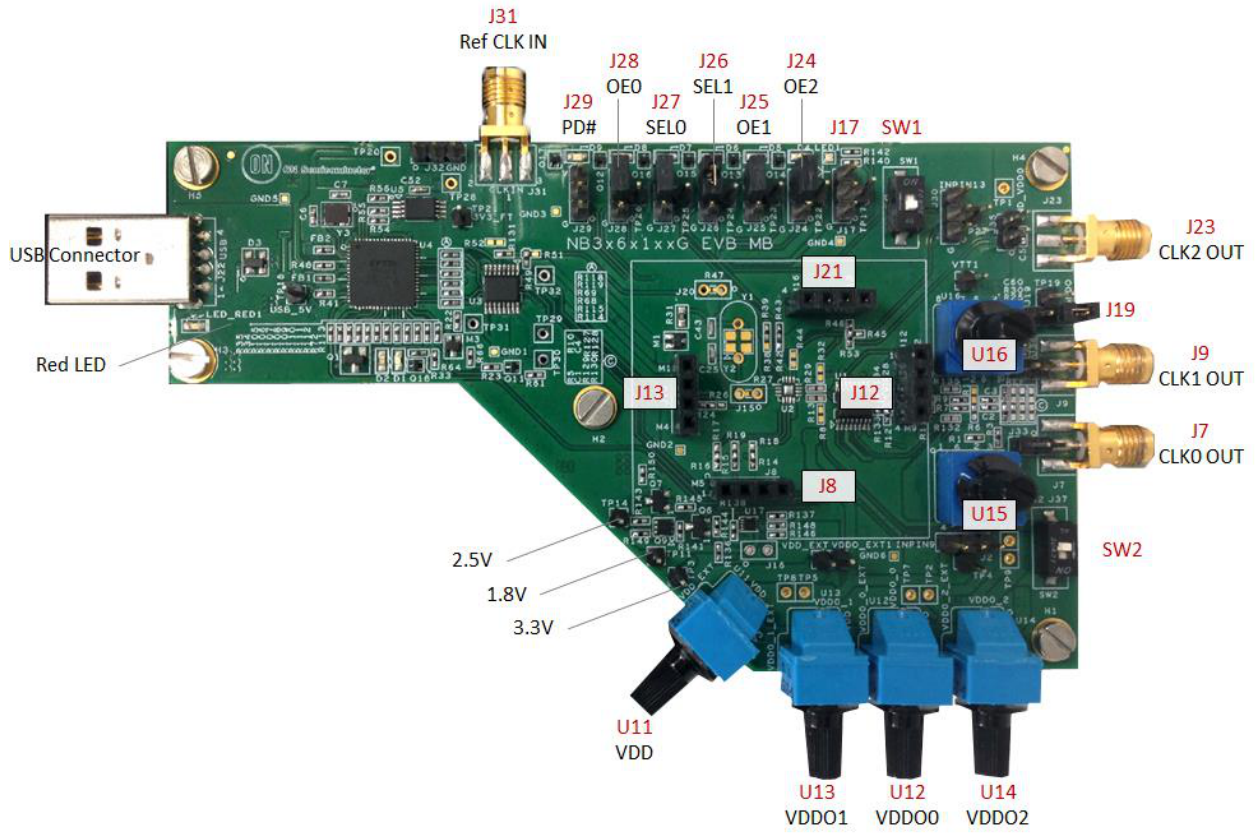

Figure 3. Main Board

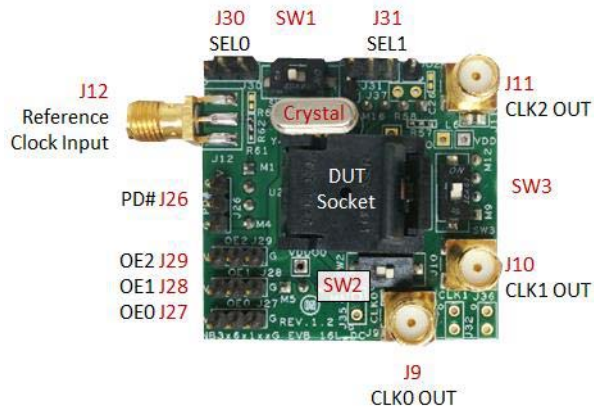

Figure 4. 16QFN Daughter Board

NB3x6x1xxG16QFNEVK

USING THE EVALUATION KIT

Setting Up for Programming

Skip this section if the device has been programmed already

- Securely connect the daughter board to the main board by lining up all four 4-pin connectors (J8, J12, J13, J21). The daughter board can only be

plugged in to the main board correctly in one orientation.

- Make sure that all SMA cables are unplugged from both boards.

- Set main board to initial position:

a. Jumpers:

use shorting links to provide connection as in the table below: (pin 1 is indicated by a circle)

Jumper No	J26 (SEL1)	J27 (SEL0)	J24 (OE2)	J25 (OE1)	J28 (OE0)	J29 (PD#)	J19
Pin connection	2 and 3	2 and 3	2 and 3	2 and 3	2 and 3	OPEN	2 and 3

b. Switches:

slide the switches to the position as in the table below: (ON is indicated in lettering on switch's case)

Switch No	SW1	SW2
Position	ON	ON

c. Rotary Switches:

turn knob on all rotary switches as shown below: (the position number will be displayed in a slit on the knob)

Jumper No	U11	U12	U13	U14	U15	U16
Dial Display	1	1	1	1	1	1

- Set daughter board to initial position:

a. Jumpers:

use shorting links to provide connection as in the table below: (pin 1 is indicated by a circle)

Jumper No	J31 (SEL1)	J30 (SEL0)	J29 (OE2)	J28 (OE1)	J27 (OE0)	J26 (PD#)
Shorting Link Position	OPEN	OPEN	OPEN	OPEN	OPEN	OPEN

b. Switches:

slide the switches to the position as in the table below: (ON is indicated in lettering on switch's case)

Switch No	SW1	SW2	SW3
Position	ON	ON	ON

- c. Make sure that the Crystal is in its holder.

- d. Place NB3H63143G in the DUT socket U2. For pin 1 alignment refer to Figure 2

Powering Up

- Download and install Clock Cruiser GUI Software to a computer that meets or exceeds minimum requirements found on Clock Cruiser User Guide.
- Connect the evaluation kit to an USB port using the included USB cable. An LED next to the USB connector will glow red, indicating +5 V supply is available to the module.

Programming the Device : OTP or Temporary Register

Skip this section if the device has been programmed already

- Run the Clock Cruiser GUI software by clicking on the desktop short cut or from the start menu. A blue LED (D9) will light up when a connection is established. This will periodically blink as activity is conducted.
- Follow the Clock Cruiser User Guide for detailed instruction on navigating through the program.
- In the Device Programming Screen, a table indicates the summary of configurations that were selected. Verify that the Hardware Connected indicator is green and that there is no error in the log. Program the device permanently by selecting [Program OTP Memory]. To write to device registers, click [Write to Registers]. In this case, when the evaluation kit is powered down (i.e. when the USB cable is unplugged) the register memory will be reset.

NB3x6x1xxG16QFNEVK

Powering up the DUT

10. Set VDD and then VDDO for each output by using the four rotary switches (U11, U12, U13, U14) to match device configuration. Make sure that

VDDOs are less than or equal to VDD. The following table shows which on-board LDO voltage is selected depending on the switch position (see table):

Rotary Switch	Line	Voltage for Each Switch Position			
		1	2	3	4
U11	VDD	+3.3 V	+2.5 V	+1.8 V	external source
U12	VDDO0	VDD			
U13	VDDO1				
U14	VDDO2				

Connect Input Clock Source

11. Depending on the programmed configuration, select one of the following input clock sources:
- Crystal: The evaluation kit comes equipped with a 25 MHz fundamental crystal on the daughter board. If a different frequency crystal (accepts 3 M to 50 MHz) is to be used, place this crystal in its holder.
 - External Reference Clock: To use an external reference clock (3 M to 200 MHz), connect the clock to J31 SMA connector on the main board.

Set Output Termination

12. The outputs from DUT are routed to three SMA connectors on the main board (J7, J9, J23) to provide CLK0, CLK1, and CLK2 respectively. By turning the rotary switches U15 and U16, the board will automatically terminate the programmed output level for CLK0 and CLK1, according to this table:

Rotary Switch Position	U15 output for CLK0	U16 output for CLK1
1	LVC MOS	LVC MOS
2	HCSL	HCSL
3	LVPECL	LVPECL
4	CML	CML
5	LVDS	LVDS

Since CLK2 output only supports LVC MOS, the termination is fixed.

Interfacing the Output to Equipment

13. To monitor the output from the main board using test equipment such as an oscilloscope, either use SMA connectors or jumpers:
- To use the jumpers (J33, J34, J35), use a high-z probe to monitor the outputs with the live connected to jumper pin marked 0, and the other pin connected to ground. This can be used for monitoring all output types.
- To use the SMA connectors (J7, J9, J23), use high-z termination on the scope and the outputs can be monitored for all types.

Controlling the Device

14. Use control pins OE[2:0] (J24, J25, J28) to enable or disable each output individually. The logic state of each signal corresponds to the LEDs (D4, D5, D8) on the main board: the LED is lit when 'high' and off when 'low'.
15. The pins SEL[1:0] (J26, J27) are used to select one of the four programmed solutions in the device's OTP memory. The logic state of each signal corresponds to the LEDs (D6, D7) on the main board: the LED is lit when 'high' and off when 'low'.
16. PD# (J29 on main board, J26 on daughter board) is used to power down the device. The logic state of the signal corresponds to the LED (D9) on the main board: the LED is lit when 'high' and off when 'low'.
17. If the configuration written into the temporary register must to be changed, re-initialize the hardware setup by returning to step 1 of this manual. Then, either return to the previous screen on the GUI with the [back] button or restarting the program.
- Note that even when the part's OTP memory has been programmed, device's registers can be used to write other solutions for evaluation.

NB3x6x1xxG16QFNEVK

Remember:

- 18. Always make sure that while communicating between the GUI and the device:
On the main board
 - a. Switches SW1 and SW2 are in ON position
 - b. Rotary switches U15 and U16 are in position '1'

- c. All SMA cables, if connected, are detached from equipment
- On the daughter board
- d. Switches SW1, SW2 and SW3 are set to ON position
 - e. All SMA cables, if connected, are detached from equipment

APPENDIX

Unpopulated Boards

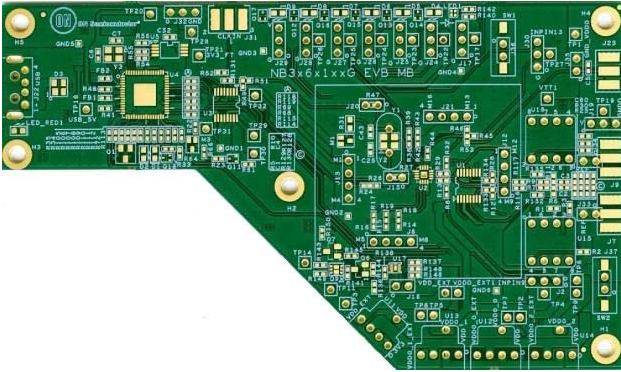

Figure 5. Main Board Top View

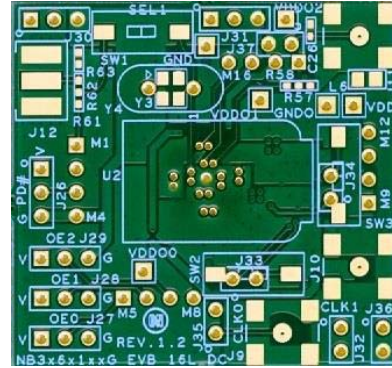

Figure 7. QFN16 Daughter Board Top View

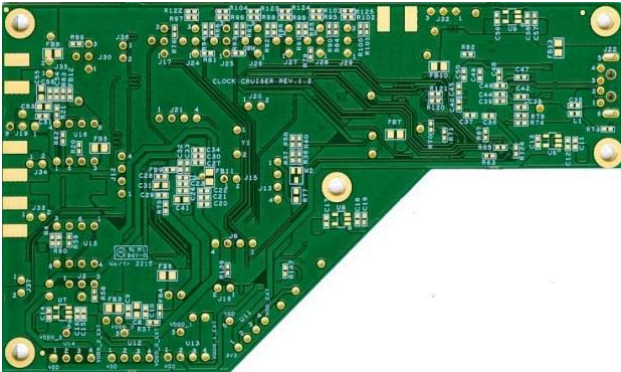

Figure 6. Main Board Bottom View

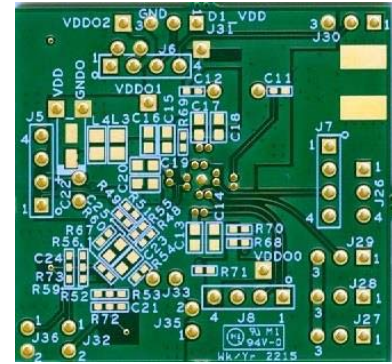

Figure 8. QFN16 Daughter Board Bottom View

NB3x6x1xxG16QFNEVK

OUTPUT TERMINATION

<p>HCSL</p>	
<p>CML</p>	
<p>LVPECL</p>	<p>Mount 50E for LVPECL (VIT)</p> <p>REF << 2</p> <p>Note: Default value of R4, R3, R25, R30 for VDDO_1=3.3V</p> <p>NP for LVPECL (VIT)</p>
<p>LVDS</p>	

NB3x6x1xxG16QFNEVK

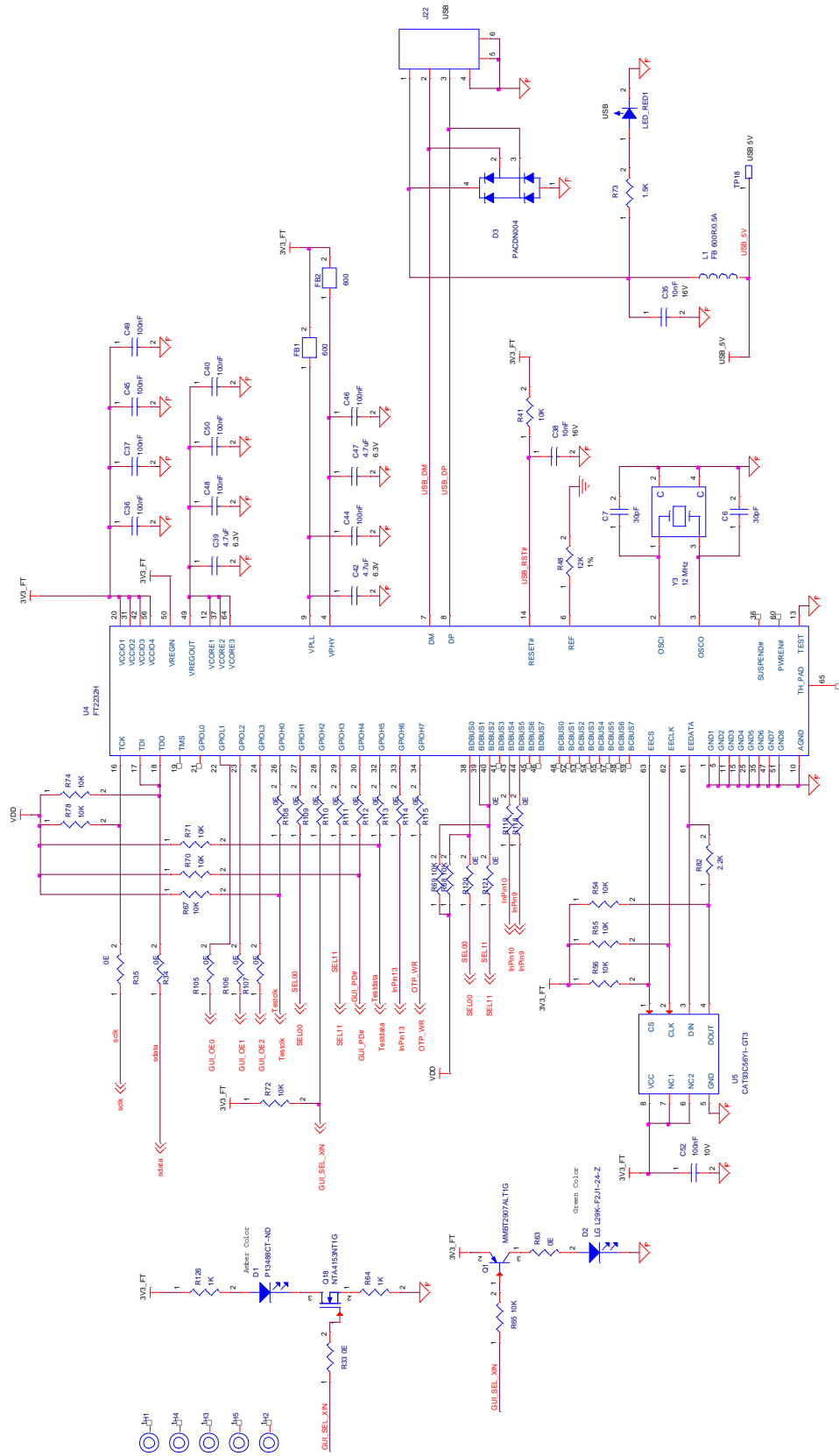

NB3x6x1xxG16QFNEVK

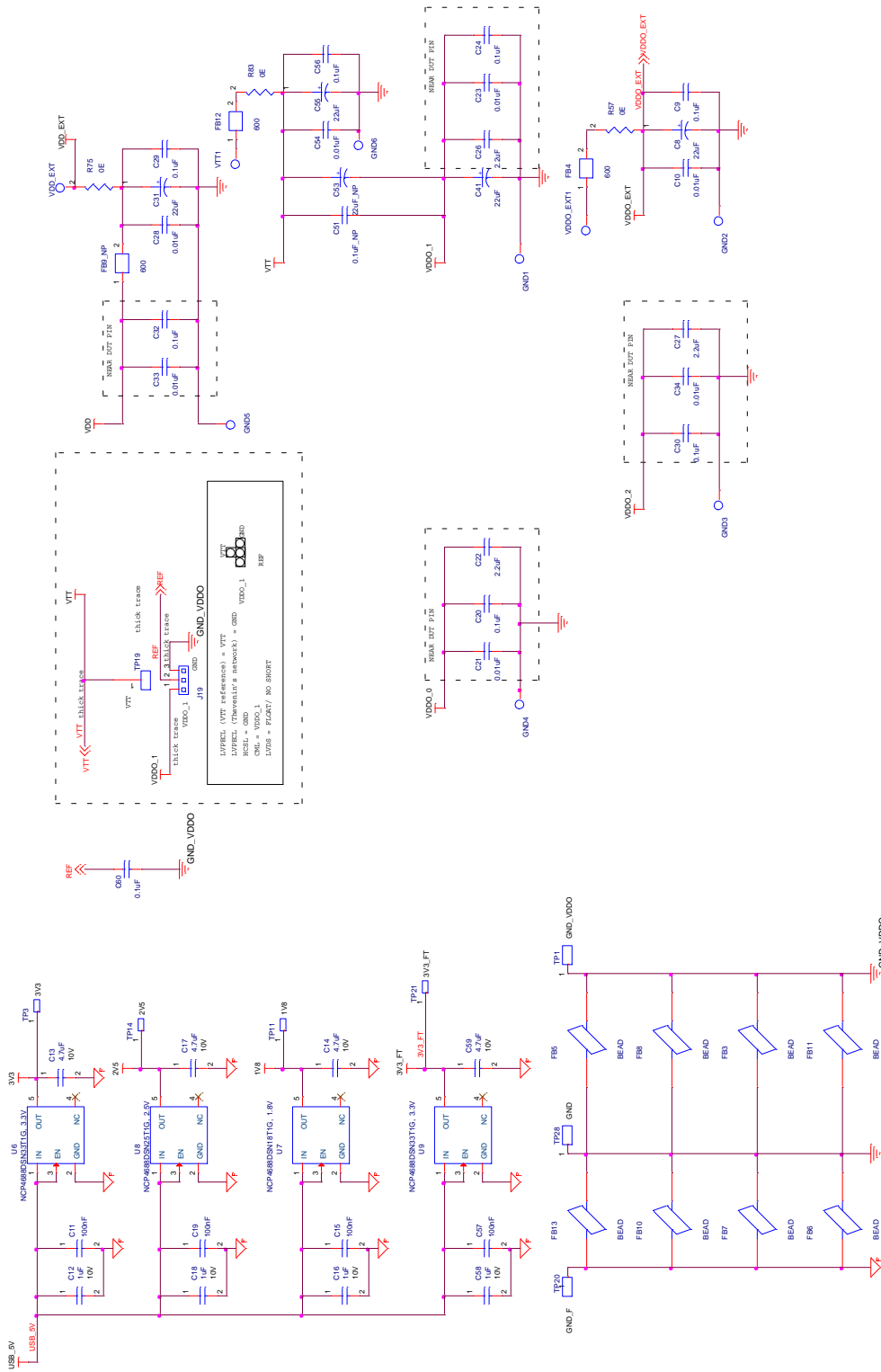

Figure 11. Main Board Schematic (3 of 3)

NB3x6x1xxG16QFNEVK

16QFN Daughter Board Schematic

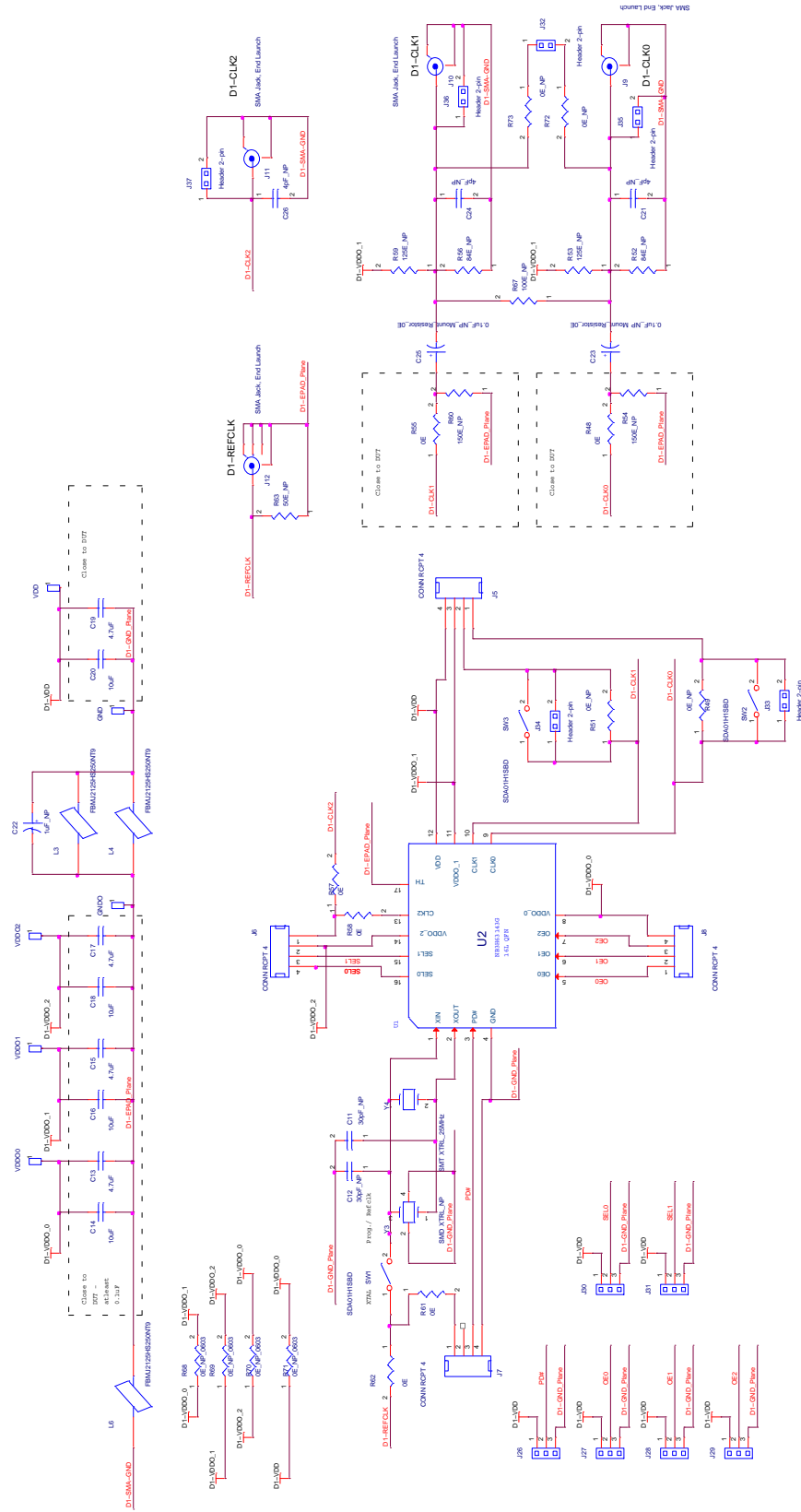

Figure 12. 16QFN Daughter Board Schematic

NB3x6x1xxG16QFNEVK

BILL OF MATERIAL MAIN BOARD

SI No	Reference	Part	PCB Footprint	Vendor	Vendor PN	Manufacturer	Manufacturer Part#	Description	Qty	Notes / Remarks
1	C2,C3	0.01 μ F _Mount R0E	R0402	DigiKey	541-0.0JCT-ND	Vishay Dale	CR-CW0402000 0Z0ED	RES SMD 0.0 OHM JUMPER 1/16W	2	
2	C8,C31, C41,C55	22 μ F	C0603	DigiKey	587-2085-1-ND	Taiyo Yuden	AMK107BJ2 26MA-T	CAP CER 22UF 4V 20% X5R 0603	4	
3	C9,C20, C24,C29, C30,C32, C56,C60	0.1 μ F	C0402	DigiKey	587-1227-1-ND	Taiyo Yuden	LMK105BJ1 04KV-F	CAP CER 0.1UF 10V 10% X5R 0402	8	
4	C10,C21, C23,C28, C33,C34, C54	0.01 μ F	C0402	DigiKey	490-1312-1-ND	Murata	GRM155R7 1E103KA01-D	CAP CER 10000PF 25V 10% X7R 0402	7	
5	C11,C15, C19,C36, C37,C40, C44,C45, C46,C48, C49,C50, C52,C57	100 nF	C0402	DigiKey	478-1129-1-ND	AVX	0402ZD104- KAT2A	CAP CER 0.1UF 10V 10% X5R 0402	14	
6	C12,C16, C18,C58	1 μ F	C0402	DigiKey	490-5409-1-ND	Murata	GRM155R6 1A105ME15-D	CAP CER 1UF 10V 20% X5R 0402	4	
7	C13,C14, C17,C59	4.7 μ F	C0402	DigiKey	490-5408-1-ND	Murata	GRM155R6 0J475ME87-D	CAP CER 4.7UF 6.3V 20% X5R 0402	4	
8	C22,C26, C27	2.2 μ F	C0402	DigiKey	490-4518-1-ND	Murata	GRM155R6 0G225ME15-D	CAP CER 2.2UF 4V 20% X5R 0402	3	
9	C35,C38	10 nF	C0402	DigiKey	478-1114-1-ND	AVX	0402YC103- KAT2A	CAP CER 10000PF 16V 10% X7R 0402	2	
10	C39,C42, C47	4.7 μ F	C0402	DigiKey	490-5408-1-ND	Murata	GRM155R6 0J475ME87-D	CAP CER 4.7UF 6.3V 20% X5R 0402	3	
11	D1	LED_amber	LED_0603	DigiKey	P13488CT-ND	Panasonic	LNJ414K82- RA	LED AMBER HIGH BRIGHT USS 0603	1	
12	D2,D4,D5, D6,D7,D8	LED_green-LG L29K-F2J1-24-Z	LED_0603	DigiKey	475-3118-1-ND	OSRAM Op-to Semiconductors Inc	LG L29K-F2J1-24-Z	LED SMARTLED 570NM GREEN 0603	6	
13	D3	PACDN004S-R	SOT-143	Mouser	748-PACDN004SR	ON Semi			1	
14	D9	LB Q39G-L2N2-35-1	LED_0603	DigiKey	475-2816-1-ND	OSRAM Op-to Semiconductors Inc	LB Q39G-L2N2-35-1	LED CHIPLED BLUE 470NM 0603 SMD	1	
15	FB1,FB2, FB4,FB12	600	L0402	DigiKey	490-1006-1-ND	Murata	BLM15AG60 1SN1D	FERRITE CHIP 600 OHM 300MA 0402	4	
16	FB3,FB5, FB6,FB7, FB8,FB10, FB11,FB13	BEAD	L0805	DigiKey	587-1767-1-ND	Taiyo Yuden	FB-MJ2125HS2 50NT	FERRITE BEAD 25 OHM 0805	8	
17	GND1, GND2, GND3, GND4, GND5, GND6	T POINT R	TP_30_30	NA	NA	NA	NA	NA	6	Test Point
18	H1,H2,H3, H4,H5	.129 Hole in .240 Round Pad	MH_240_128	NA	NA	NA	NA	NA	5	Round Pad
19	J2,J17,J19, J24,J25, J26,J27, J28,J29, J30,J32	Header 3-pin	berg_1x3_2p54	DigiKey	3M9448-ND	3M	961103-640 4-AR	CONN HEADER VERT SGL 3POS GOLD	11	
20	J7,J9,J23, J31	SMA-J-P-H-ST-EM1-ND	con_sma_edge	DigiKey	SMA-J-P-H-ST-EM1	Samtec Inc	SMA-J-P-H-ST-EM1	CONN SMA JACK 50 OHM EDGE MNT	4	
21	J8,J12, J13,J21	4 HEADER	berg_1x4_2p54	DigiKey	S7037-ND	Sullins Connector Solutions	PP-PC041LF-BN-RC	Connector Header 4 Position 0.100" (2.54mm) Gold Through Hole	4	

NB3x6x1xxG16QFNEVK

BILL OF MATERIAL MAIN BOARD

SI No	Reference	Part	PCB Footprint	Vendor	Vendor PN	Manufacturer	Manufacturer Part#	Description	Qty	Notes / Remarks
22	J15,J16, J20,J33, J34,J35, J36,J37	SMDHeader 2-pin	berg_1x2_2p54	DigiKey	3M5350-ND	3M	151204-2320-RB	CONN 4POS 2MM HEADER DL STR SMD	8	
23	J22	Conn. USB-B, SMT	USB_A_-PLUG_RA	DigiKey	WM17117-ND	Molex	480370001	Connector Plug USB TypeA 2.0 4 Position Through Hole, Right Angle, Horizontal	1	
24	LED_RED1	LED, Green	LED_0603	DigiKey	P11475CT-ND	Panasonic	LNJ212R82-RA	LED RED TSS TYPE 0603	1	
25	LED1	846-1040-1-ND	LED_SM-L_DUO	DigiKey	846-1040-1-ND	Rohm Semiconductor	SML-P24MUWT86	LED PICOLED DUAL YWGN/RED 1010	1	
26	L1	FB 600R/0.5A	L0402	DigiKey	490-5258-1-ND	Murata	BLM18KG601SN1D	FERRITE CHIP 600 OHM 1300MA 0603	1	
27	M1,M2,M3	NTS2101P/ON	sot-323	DigiKey	NTS2101PT1-GOSCT-ND	ON Semi	NTS2101PT1G	MOSFET P-CH 8V 1.4A SOT-323	3	
28	Q1	MMBT2907A-LT1G	sot_23	DigiKey	MMBT2907ALT3GOSCT-ND	ON Semi	MMBT2907-ALT3G	TRANS PNP 60V 0.6A SOT-23	1	
29	Q6,Q7	50C02CH-TL-E	sot-23	DigiKey	50C02CH-TL-EOSCT-ND	ON Semi	50C02CH-TL-E	TRANS NPN 50V 0.5A CPH3	2	
30	Q9	NTLJD3115PT1G	6-WDFN (2X2)	DigiKey	NTLJD3115PT1GOSCT-ND	ON Semi	NTLJD3115PT1G	MOSFET 2P-CH 20V 2.3A 6-WDFN	1	
31	Q11,Q12, Q13,Q14, Q15,Q16, Q17,Q18	NTA4153NT1G	sot-416	DigiKey	NTA4153NT1-GOSCT-ND	ON Semi	NTA4153NT1G	MOSFET N-CH 20V 915MA SOT-416	8	
32	R1,R2, R20,R21, R36,R40, R59,R62	50E	R0402	DigiKey	P49.9LDKR-ND	Panasonic	ERJ-2RKF49R9X	RES SMD 49.9 OHM 1% 1/10W 0402	8	
33	R3,R25	125E	R0402	DigiKey	P124LCT-ND	Panasonic	ERJ-2RKF1240X	RES SMD 124 OHM 1% 1/10W 0402	2	
34	R4,R30	84E	R0402	DigiKey	P84.5LCT-ND	Panasonic	ERJ-2RKF84R5X	RES SMD 84.5 OHM 1% 1/10W 0402	2	
35	R5,R10, R12,R14, R15,R16, R24,R28, R33,R34, R35,R39, R43,R46, R49,R57, R63,R75, R83, R84, R85, R86, R87, R88, R90,R91, R92, R93, R94, R100, R101, R105, R106, R107, R108, R109, R110, R111, R112, R113, R114, R115, R118, R119, R120, R121, R131	0E	R0402	DigiKey	541-0.0JCT-ND	Vishay Dale	CR-CW04020000Z0ED	RES SMD 0.0 OHM JUMPER 1/16W	47	
36	R7,R9,R53	0E	R0402	DigiKey	541-0.0JCT-ND	Vishay Dale	CR-CW04020000Z0ED	RES SMD 0.0 OHM JUMPER 1/16W	3	
37	R116,R117, R149	0E	R0402	DigiKey	541-0.0JCT-ND	Vishay Dale	CR-CW04020000Z0ED	RES SMD 0.0 OHM JUMPER 1/16W	3	

NB3x6x1xxG16QFNEVK

BILL OF MATERIAL MAIN BOARD

SI No	Reference	Part	PCB Footprint	Vendor	Vendor PN	Manufacturer	Manufacturer Part#	Description	Qty	Notes / Remarks
38	R22,R41, R54,R55, R56,R58, R61,R65, R67,R68, R69,R70, R71,R72, R74,R76, R78,R79, R80,R81, R89,R136, R150	10K	R0402	DigiKey	P10KJCT-ND	Panasonic	ERJ-2GEJ1 03X	RES SMD 10K OHM 5% 1/10W 0402	23	
39	R23,R82	2.2K	R0402	DigiKey	P2.2KJCT-ND	Panasonic	ERJ-2GEJ2 22X	RES SMD 2.2K OHM 5% 1/10W 0402	2	
40	R31,R77	82E	R0603	DigiKey	541-82.0HC-T-ND	Vishay Dale	CR-CW060382R 0FKEA	RES SMD 82 OHM 1% 1/10W 0603	2	
41	R37,R50	50K	R0402	DigiKey	P10KJCT-ND	Panasonic	ERJ-2GEJ1 03X	RES SMD 10K OHM 5% 1/10W 0402	2	
42	R48	12K	R0402	DigiKey	P12.0KLCT-ND	Panasonic	ERJ-2RKF1 202X	RES SMD 12K OHM 1% 1/10W 0402	1	
43	R64,R66, R103,R104,- R122,R123,- R124,R125,- R126, R141,R143, R140,R142	1K	R0402	DigiKey	P1.0KJCT-ND	Panasonic	ERJ-2GEJ1 02X	RES SMD 1K OHM 5% 1/10W 0402	13	
44	R73	1.5K	R0402	DigiKey	P1.5KJCT-ND	Panasonic	ERJ-2GEJ1 52X	RES SMD 1.5K OHM 5% 1/10W 0402	1	
45	R137,R138	22K	R0402	DigiKey	P22KJCT-ND	Panasonic	ERJ-2GEJ2 23X	RES SMD 22K OHM 5% 1/10W 0402	2	
46	R148	8.2K	R0402	DigiKey	P8.2KJCT-ND	Panasonic	ERJ-2GEJ8 22X	RES SMD 8.2K OHM 5% 1/10W 0402	1	
47	R139	47K	R0402	DigiKey	P47KJCT-ND	Panasonic	ERJ-2GEJ4 73X	RES SMD 47K OHM 5% 1/10W 0402	1	
48	R144,R145	33K	R0402	DigiKey	P33KJCT-ND	Panasonic	ERJ-2GEJ3 33X	RES SMD 33K OHM 5% 1/10W 0402	2	
49	R146	3.3K	R0402	DigiKey	P3.3KJCT-ND	Panasonic	ERJ-2GEJ3 32X	RES SMD 3.3K OHM 5% 1/10W 0402	1	
50	SW1,SW2	SDA01H1SBD		DigiKey	CKN10358-ND	C&K Components	SDA01H1-SBD	SWITCH DIP TAPE SEALED 1POS 24V	2	
51	TP1,TP2, TP5,TP6, TP7,TP8, TP9,TP20, TP28	Test Pad 50 x 100 mil	NA	NA	NA	NA	NA	NA	9	Test point
52	TP3,TP4, TP11,TP14, TP17,TP18, TP21,TP22, TP23,TP24, TP25,TP26, TP27,TP19	Test Pad 30 x 60 mil	TP_70_36	DigiKey	732-5314-ND	Wurth Electronics Inc	6130011112 1	CONN HEADER 1 POS 2.54	14	
53	U1,U3	ADG3257BR-QZ	QSOP_16-P_25MIL	DigiKey	ADG3257BRQ-Z-ND	Analog Devices	ADG3257BR-QZ	IC MUX QUAD 3.3/5V HS 16-QSOP	2	
54	U2	NB3H63143-G	QFN_16P_0P5MM						1	ON Semiconductor part
55	U4	FT2232H	qfn_64_0p5	DigiKey	768-1025-1-ND	FTDI	FT2232HQ-REEL	IC USB HS DUAL UART/FIFO 64-QFN	1	
56	U5	CAT93C56Y1-GT3	tssop_8_4p4w_0p65	Digi-Key	CAT93C56Y1-GT3-ND	ON Semi	CAT93C56Y1-GT3	IC EEPROM 2KBIT 2MHZ 8TSSOP	1	
57	U6,U9	NCP4688DS-N33T1G, 3.3V	sot23-5	ON Semi	NCP4688DSN33T1GOSCT-ND	ON Semi	NCP4688DS-N33T1G	IC REG LDO 3.3V 0.15A SOT23-5	2	
58	U7	NCP4688DS-N18T1G, 1.8V	sot23-5	ON Semi	NCP4688DSN18T1GOSCT-ND	ON Semi	NCP4688DS-N18T1G	IC REG LDO 1.8V 0.15A SOT23-5	1	
59	U8	NCP4688DS-N25T1G, 2.5V	sot23-5	ON Semi	NCP4688DSN25T1GOSCT-ND	ON Semi	NCP4688DS-N25T1G	IC REG LDO 2.5V 0.15A SOT23-5	1	

NB3x6x1xxG16QFNEVK

BILL OF MATERIAL MAIN BOARD

SI No	Reference	Part	PCB Footprint	Vendor	Vendor PN	Manufacturer	Manufacturer Part#	Description	Qty	Notes / Remarks
60	U11,U12, U13,U14	S-2151		DigiKey	563-1088-ND	Copal Electronics	S-2151	SW ROTARY DIP SP4T SIDE KNOB 5V	4	
61	U15,U16	SS-10-15S-P-LE		DigiKey	563-1078-ND	Copal Electronics	SS-10-15S-P-LE	SWITCH ROTARY DIP SP5T TOP 5V	2	
62	U17	NCS2220AM-UT1G	8L_udfn_0P4	DigiKey	NCS2220AMU-T1GOSCT-ND	ON Semi	NCS2220A-MUT1G	IC COMPARATOR DUAL LV 8UDFN	1	
63	VTT1, VD-DO_EXT1, VDD_EXT	T POINT R	TP_70_36	DigiKey	732-5314-ND	Wurth Electronics Inc	61300111121	CONN HEADER 1 POS 2.54	3	
64	Y1	SMT XTRL_25MHZ	CRY_EC-X_6150	ECLIPT-EK	ECX615025.000M	ECLIPTTEK			1	Based on Crystal values
65	Y3	12 MHz	CRY-ABM8G	Digi-Key	535-10901-1-ND	Abrakon Corp	ABM8G-12.000MHZ-4Y-T3	Crystal 12.0000MHz 30ppm 10pF 120 Ohm -10°C - 60°C Surface Mount 4-SMD, No Lead (DFN, LCC)	1	
66	H1,H2,H3, H4,H5 (Mechanical)	Standoff, 4-40 1/4 x 5/8	Standoff, 4-40 1/4 x 5/8	DigiKey	1808K-ND	Keystone	1808	HEX STANDOFF 4-40 ALUMINUM 5/8"	5	
67	To be used with these connectors- J24,J25, J26,J27, J28,J19 and as spare.	Shunt	Shunt	DigiKey	3M9580-ND	3M	969102-0000-DA	SHUNT JUMPER .1" BLACK GOLD	11	
68	H1,H2,H3, H4,H5 (Mechanical)	Screw, 4-40 x 0.25, PHP	Screw, 4-40 x 0.25, PHP	DigiKey	H342-ND	Building Fasteners	PMS 440 0025 PH	MACHINE SCREW PAN PHILLIPS 4-40	5	
69	VTT1, VD-DO_EXT1, VDD1	T POINT R	TP_70_36	DigiKey	732-5314-ND	Wurth Electronics Inc	61300111121	CONN HEADER 1 POS 2.54	4	
70	To be used with these Switches- U11,U12, U13,U14, U15,U16	Switch Knob Black		DigiKey	563-1089-ND	Copal Electronics	K1	SWITCH KNOB BLACK	6	

NB3x6x1xxG16QFNEVK

BILL OF MATERIAL DAUGHTER BOARD

SI No	Reference	Part	PCB Footprint	Vendor	Vendor PN	Manufacturer	Qty
1	C13, C15, C17, C19	4.7 μ F	C0603	DigiKey	587-1782-1-ND	Taiyo Yuden	4
2	C23, C25	0E	R0603	DigiKey	541-0.0GCT-ND	Vishay Dale	2
3	C14, C16, C18, C20	10 μ F	C0603	DigiKey	587-3383-1-ND	Taiyo Yuden	4
4	VDDO1, VDDO2, VDDO0, VDD, GNDO, GND	Test Pad 30 x 60 mil	TP_70_36	DigiKey	732-5314-ND	Würth Electronics Inc	6
5	J5, J6, J7, J8	CONN RCPT 4	BERG_1X4_2P54	DigiKey	S1011EC-04-ND	Sullins Connector Solutions	4
6	J12	SMA-J-P-H-ST-EM1-ND	con_sma_edge	DigiKey	SMA-J-P-H-ST-EM1	Samtec Inc	1
7	J9, J10, J11	CONS-MA001-SMD-G-ND	Con_SMA_SMD	DigiKey	CONS-MA001-SMD-G	Linx Technologies Inc	3
8	J26, J27, J28, J29, J30, J31	Header 3-pin	berg_1x3_2p54	DigiKey	3M9448-ND	3M	6
9	L3, L4, L6	FB-MJ2125HS250NT9	L0805	DigiKey	587-1767-1-ND	Taiyo Yuden	3
10	R58, R61, R62, R48, R55, R57	0E	R0402	DigiKey	541-0.0JCT-ND	Panasonic	6
11	SW1, SW2, SW3	SDA01H1SBD	NA	DigiKey	CKN10358-ND	C&K Components	3
12	U2	Socket	SOCK_16L_QFN	Loranger	03714 171 6217	Loranger	1
13	Y3	SMT XTRL_25MHz	CRY_ECX_6150	ECLIPTEK	ECX-6150-25.000M	ECLIPTEK	1
14	Y3	ED1290-ND	SKT CONTACT	DigiKey	8975-0-15-15-21-27-10-0	Mill-Max	2

ON Semiconductor and the  are registered trademarks of Semiconductor Components Industries, LLC (SCILLC) or its subsidiaries in the United States and/or other countries. SCILLC owns the rights to a number of patents, trademarks, copyrights, trade secrets, and other intellectual property. A listing of SCILLC's product/patent coverage may be accessed at www.onsemi.com/site/pdf/Patent-Marking.pdf. SCILLC reserves the right to make changes without further notice to any products herein. SCILLC makes no warranty, representation or guarantee regarding the suitability of its products for any particular purpose, nor does SCILLC assume any liability arising out of the application or use of any product or circuit, and specifically disclaims any and all liability, including without limitation special, consequential or incidental damages. "Typical" parameters which may be provided in SCILLC data sheets and/or specifications can and do vary in different applications and actual performance may vary over time. All operating parameters, including "Typicals" must be validated for each customer application by customer's technical experts. SCILLC does not convey any license under its patent rights nor the rights of others. SCILLC products are not designed, intended, or authorized for use as components in systems intended for surgical implant into the body, or other applications intended to support or sustain life, or for any other application in which the failure of the SCILLC product could create a situation where personal injury or death may occur. Should Buyer purchase or use SCILLC products for any such unintended or unauthorized application, Buyer shall indemnify and hold SCILLC and its officers, employees, subsidiaries, affiliates, and distributors harmless against all claims, costs, damages, and expenses, and reasonable attorney fees arising out of, directly or indirectly, any claim of personal injury or death associated with such unintended or unauthorized use, even if such claim alleges that SCILLC was negligent regarding the design or manufacture of the part. SCILLC is an Equal Opportunity/Affirmative Action Employer. This literature is subject to all applicable copyright laws and is not for resale in any manner.

PUBLICATION ORDERING INFORMATION

LITERATURE FULFILLMENT:

Literature Distribution Center for ON Semiconductor
 19521 E. 32nd Pkwy, Aurora, Colorado 80011 USA
Phone: 303-675-2175 or 800-344-3860 Toll Free USA/Canada
Fax: 303-675-2176 or 800-344-3867 Toll Free USA/Canada
Email: orderlit@onsemi.com

N. American Technical Support: 800-282-9855 Toll Free
 USA/Canada
Europe, Middle East and Africa Technical Support:
 Phone: 421 33 790 2910
Japan Customer Focus Center
 Phone: 81-3-5817-1050

ON Semiconductor Website: www.onsemi.com

Order Literature: <http://www.onsemi.com/orderlit>

For additional information, please contact your local Sales Representative



Стандарт Электрон Связь

Мы молодая и активно развивающаяся компания в области поставок электронных компонентов. Мы поставляем электронные компоненты отечественного и импортного производства напрямую от производителей и с крупнейших складов мира.

Благодаря сотрудничеству с мировыми поставщиками мы осуществляем комплексные и плановые поставки широчайшего спектра электронных компонентов.

Собственная эффективная логистика и склад в обеспечивает надежную поставку продукции в точно указанные сроки по всей России.

Мы осуществляем техническую поддержку нашим клиентам и предпродажную проверку качества продукции. На все поставляемые продукты мы предоставляем гарантию .

Осуществляем поставки продукции под контролем ВП МО РФ на предприятия военно-промышленного комплекса России , а также работаем в рамках 275 ФЗ с открытием отдельных счетов в уполномоченном банке. Система менеджмента качества компании соответствует требованиям ГОСТ ISO 9001.

Минимальные сроки поставки, гибкие цены, неограниченный ассортимент и индивидуальный подход к клиентам являются основой для выстраивания долгосрочного и эффективного сотрудничества с предприятиями радиоэлектронной промышленности, предприятиями ВПК и научно-исследовательскими институтами России.

С нами вы становитесь еще успешнее!

Наши контакты:

Телефон: +7 812 627 14 35

Электронная почта: sales@st-electron.ru

Адрес: 198099, Санкт-Петербург,
Промышленная ул, дом № 19, литера Н,
помещение 100-Н Офис 331