

74AXP1T57

Dual supply configurable multiple function gate

Rev. 5 — 3 July 2017

Product data sheet

1 General description

The 74AXP1T57 is a dual supply configurable multiple function gate with Schmitt-trigger inputs. It features three inputs (A, B and C), an output (Y) and dual supply pins (V_{CCI} and V_{CCO}). The inputs are referenced to V_{CCI} and the output is referenced to V_{CCO} . All inputs can be connected directly to V_{CCI} or GND. V_{CCI} can be supplied at any voltage between 0.7 V and 2.75 V and V_{CCO} can be supplied at any voltage between 1.2 V and 5.5 V. This feature allows voltage level translation. The 74AXP1T57 can be configured as any of the following logic functions AND, OR, NAND, NOR, XNOR, inverter and buffer.

This device ensures very low static and dynamic power consumption across the entire supply range and is fully specified for partial power down applications using I_{OFF} . The I_{OFF} circuitry disables the output, preventing the potentially damaging backflow current through the device when it is powered down.

2 Features and benefits

- Wide supply voltage range:
 - V_{CCI} : 0.7 V to 2.75 V
 - V_{CCO} : 1.2 V to 5.5 V
- Low input capacitance; $C_I = 0.6$ pF (typical)
- Low output capacitance; $C_O = 1.8$ pF (typical)
- Low dynamic power consumption; $C_{PD} = 0.6$ pF at $V_{CCI} = 1.2$ V (typical)
- Low dynamic power consumption; $C_{PD} = 7.1$ pF at $V_{CCO} = 3.3$ V (typical)
- Low static power consumption; $I_{CCI} = 0.5$ μ A (85 °C maximum)
- Low static power consumption; $I_{CCO} = 1.8$ μ A (85 °C maximum)
- High noise immunity
- Complies with JEDEC standard:
 - JESD8-12A.01 (1.1 V to 1.3 V; A, B, C inputs)
 - JESD8-11A.01 (1.4 V to 1.6 V)
 - JESD8-7A (1.65 V to 1.95 V)
 - JESD8-5A.01 (2.3 V to 2.7 V)
 - JESD8-C (2.7 V to 3.6 V; Y output)
 - JESD12-6 (4.5 V to 5.5 V; Y output)
- ESD protection:
 - HBM ANSI/ESDA/JEDEC JS-001 Class 2 exceeds 2 kV
 - CDM JESD22-C101E exceeds 1000 V
- Latch-up performance exceeds 100 mA per JESD78D Class II
- Inputs accept voltages up to 2.75 V
- Low noise overshoot and undershoot < 10 % of V_{CCO}
- I_{OFF} circuitry provides partial power-down mode operation
- Multiple package options

- Specified from -40 °C to +85 °C

3 Ordering information

Table 1. Ordering information

Type number	Package			Version
	Temperature range	Name	Description	
74AXP1T57DC	-40 °C to +85 °C	VSSOP8	plastic very thin shrink small outline package; 8 leads; body width 2.3 mm	SOT765-1
74AXP1T57GT	-40 °C to +85 °C	XSON8	plastic extremely thin small outline package; no leads; 8 terminals; body 1 x 1.95 x 0.5 mm	SOT833-1
74AXP1T57GN	-40 °C to +85 °C	XSON8	extremely thin small outline package; no leads; 8 terminals; body 1.2 x 1.0 x 0.35 mm	SOT1116
74AXP1T57GS	-40 °C to +85 °C	XSON8	extremely thin small outline package; no leads; 8 terminals; body 1.35 x 1.0 x 0.35 mm	SOT1203
74AXP1T57GX	-40 °C to +85 °C	X2SON8	plastic thermal enhanced extremely thin small outline package; no leads; 8 terminals; body 1.35 x 0.8 x 0.35 mm	SOT1233

4 Marking

Table 2. Marking

Type number	Marking code ^[1]
74AXP1T57DC	rD
74AXP1T57GT	rD
74AXP1T57GN	rD
74AXP1T57GS	rD
74AXP1T57GX	rD

[1] The pin 1 indicator is located on the lower left corner of the device, below the marking code.

5 Functional diagram

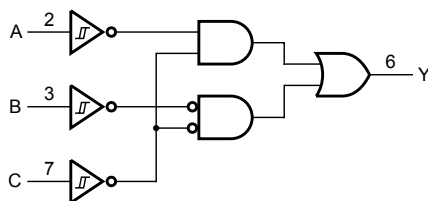

Figure 1. Logic symbol

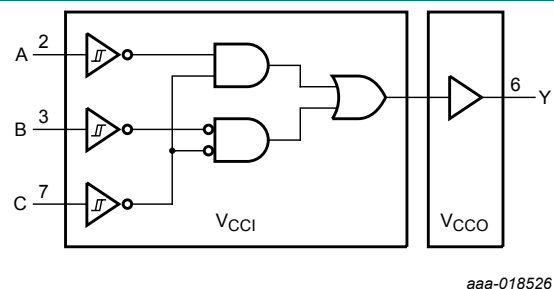
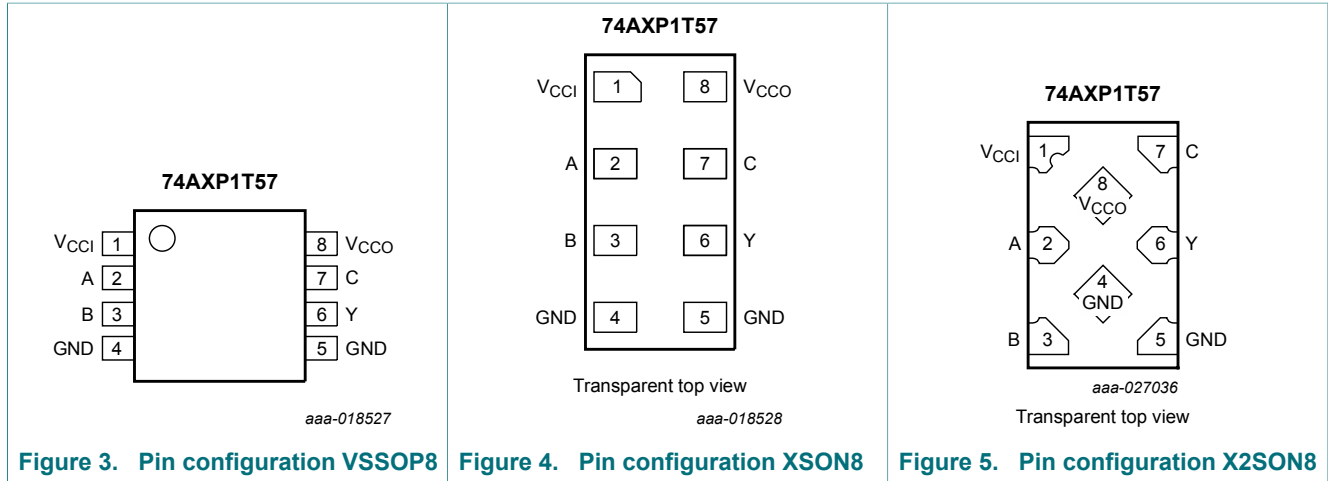

Figure 2. Logic diagram

6 Pinning information

6.1 Pinning



6.2 Pin description

Table 3. Pin description

Symbol	Pin	Description
V _{CCI}	1	input supply voltage
A, B, C	2, 3, 7	data input
GND ^[1]	4, 5	ground (0 V)
Y	6	data output
V _{CCO}	8	output supply voltage

[1] All GND pins must be connected to ground (0 V).

7 Functional description

Table 4. Function table

H = HIGH voltage level; L = LOW voltage level; X = don't care; Z = high-impedance OFF-state.

Supply voltage		Input			Output
V _{CCI}	V _{CCO}	C	B	A	Y
0.7 V to 2.75 V	1.2 V to 5.5 V	L	L	L	H
0.7 V to 2.75 V	1.2 V to 5.5 V	L	L	H	L
0.7 V to 2.75 V	1.2 V to 5.5 V	L	H	L	H
0.7 V to 2.75 V	1.2 V to 5.5 V	L	H	H	L
0.7 V to 2.75 V	1.2 V to 5.5 V	H	L	L	L
0.7 V to 2.75 V	1.2 V to 5.5 V	H	L	H	L
0.7 V to 2.75 V	1.2 V to 5.5 V	H	H	L	H
0.7 V to 2.75 V	1.2 V to 5.5 V	H	H	H	H
GND	1.2 V to 5.5 V	X	X	X	Z
0.7 V to 2.75 V	GND	X	X	X	Z
GND	GND	X	X	X	Z

7.1 Logic configurations

Table 5. Function selection table

Logic function	Figure
2-input AND	see Figure 6
2-input AND with both inputs inverted	see Figure 9
2-input NAND with inverted input	see Figure 7 and Figure 8
2-input OR with inverted input	see Figure 7 and Figure 8
2-input NOR	see Figure 9
2-input NOR with both inputs inverted	see Figure 6
2-input XNOR	see Figure 10
Inverter	see Figure 11
Buffer	see Figure 12

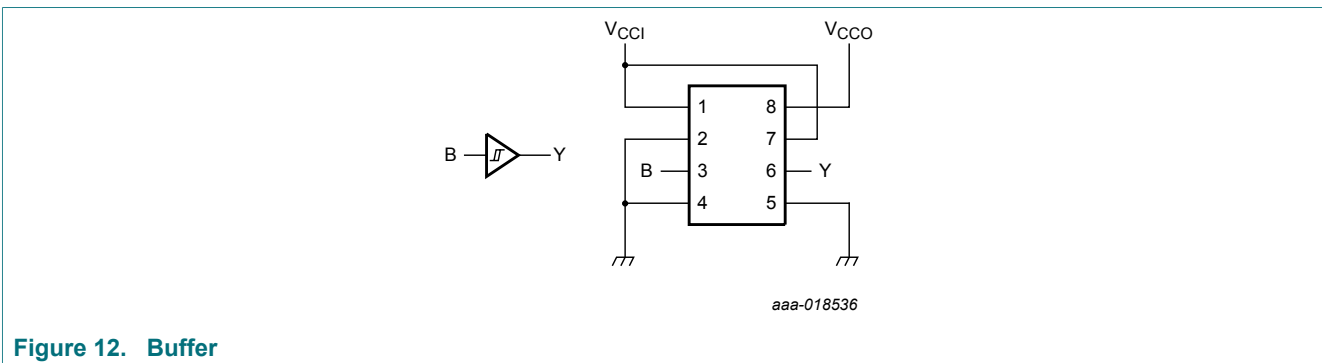
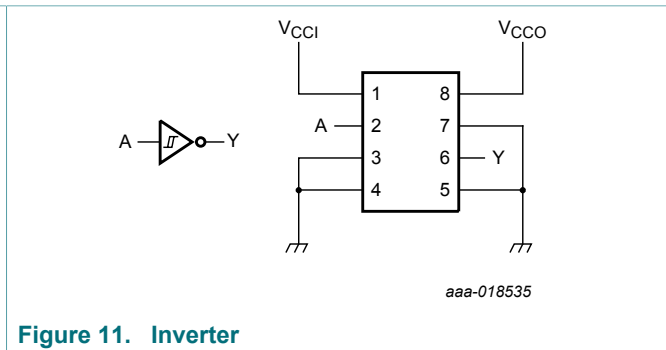
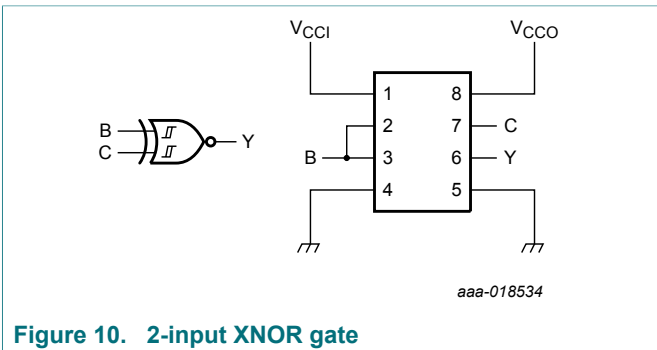
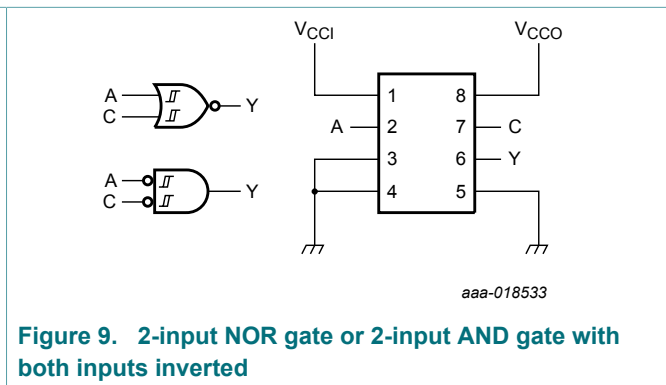
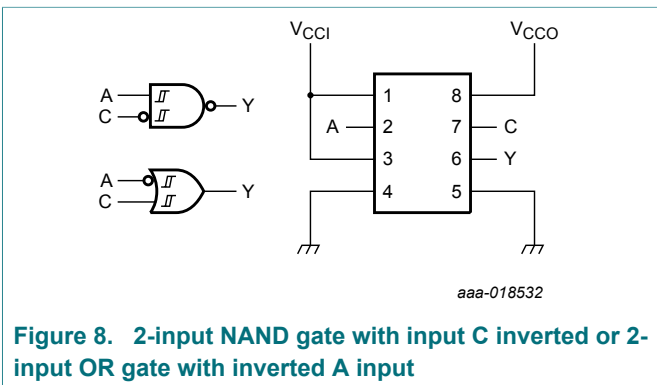
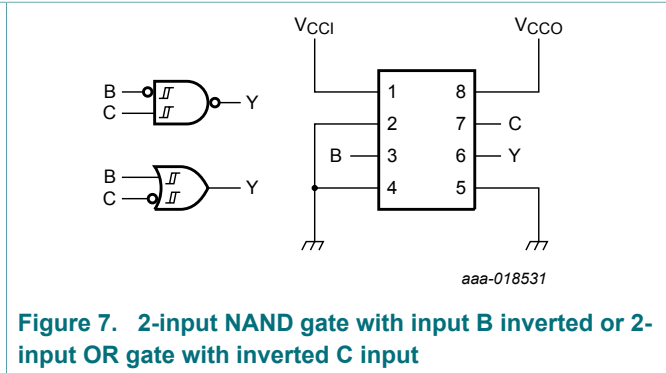

8 Limiting values

Table 6. Limiting values

In accordance with the Absolute Maximum Rating System (IEC 60134). Voltages are referenced to GND (ground = 0 V).

Symbol	Parameter	Conditions	Min	Max	Unit
V_{CCI}	input supply voltage		-0.5	+3.3	V
V_{CCO}	output supply voltage		-0.5	+6.0	V
I_{IK}	input clamping current	$V_I < 0$ V	-50	-	mA
V_I	input voltage	[1]	-0.5	+3.3	V
I_{OK}	output clamping current	$V_O < 0$ V	-50	-	mA
V_O	output voltage	Active mode [1] [2]	-0.5	$V_{CCO} + 0.5$	V
		Power-down or 3-state mode [1]	-0.5	+6.0	V
I_O	output current	$V_O = 0$ V to V_{CCO}	-	± 25	mA
I_{CCI}	input supply current		-	50	mA
I_{CCO}	output supply current		-	50	mA
I_{GND}	ground current		-50	-	mA
T_{stg}	storage temperature		-65	+150	°C
P_{tot}	total power dissipation	$T_{amb} = -40$ °C to +85 °C [3]	-	300	mW

[1] The minimum input and output voltage ratings may be exceeded if the input and output current ratings are observed.

[2] $V_{CCO} + 0.5$ V should not exceed 6.0 V.

[3] For SOT833-1 package: above 70 °C the value of P_{tot} derates linearly with 3.2 mW/K.
For SOT1203 package: above 80 °C the value of P_{tot} derates linearly with 3.6 mW/K.

9 Recommended operating conditions

Table 7. Recommended operating conditions

Voltages are referenced to GND (ground = 0 V).

Symbol	Parameter	Conditions	Min	Max	Unit
V_{CCI}	input supply voltage		0.7	2.75	V
V_{CCO}	output supply voltage		1.2	5.5	V
V_I	input voltage		0	2.75	V
V_O	output voltage	Active mode	0	V_{CCO}	V
		Power-down or 3-state mode	0	5.5	V
T_{amb}	ambient temperature		-40	+85	°C

10 Static characteristics

Table 8. Static characteristics

At recommended operating conditions, unless otherwise specified; voltages are referenced to GND (ground = 0 V).

Symbol	Parameter	Conditions	T _{amb} = -40 °C to +85 °C				Unit
			Min	Typ 25 °C	Max 25 °C	Max 85 °C	
V _{T+}	positive-going threshold voltage	see Figure 13 and Figure 14					
		V _{CCI} = 0.75 V to 0.85 V	0.3V _{CCI}	-	0.8V _{CCI}	0.8V _{CCI}	V
		V _{CCI} = 1.1 V to 1.95 V	0.4V _{CCI}	-	0.7V _{CCI}	0.7V _{CCI}	V
		V _{CCI} = 2.3 V to 2.7 V	0.9	-	1.7	1.7	V
V _{T-}	negative-going threshold voltage	see Figure 13 and Figure 14					
		V _{CCI} = 0.75 V to 0.85 V	0.2V _{CCI}	-	0.7V _{CCI}	0.7V _{CCI}	V
		V _{CCI} = 1.1 V to 1.95 V	0.3V _{CCI}	-	0.6V _{CCI}	0.6V _{CCI}	V
		V _{CCI} = 2.3 V to 2.7 V	0.7	-	1.5	1.5	V
V _H	hysteresis voltage	see Figure 13 and Figure 14					
		V _{CCI} = 0.75 V to 0.85 V	0.06V _{CCI}	-	0.5V _{CCI}	0.5V _{CCI}	V
		V _{CCI} = 1.1 V to 1.95 V	0.1V _{CCI}	-	0.4V _{CCI}	0.4V _{CCI}	V
		V _{CCI} = 2.3 V to 2.7 V	0.2	-	1.0	1.0	V
V _{OH}	HIGH-level output voltage	I _O = -2 mA; V _{CCO} = 1.2 V ^[1]	-	1.05	-	-	V
		I _O = -3 mA; V _{CCO} = 1.4 V	1.05	-	-	-	V
		I _O = -4.5 mA; V _{CCO} = 1.65 V	1.2	-	-	-	V
		I _O = -8 mA; V _{CCO} = 2.3 V	1.7	-	-	-	V
		I _O = -10 mA; V _{CCO} = 3.0 V	2.2	-	-	-	V
		I _O = -12 mA; V _{CCO} = 4.5 V	3.7	-	-	-	V
V _{OL}	LOW-level output voltage	I _O = 2 mA; V _{CCO} = 1.2 V ^[1]	-	0.18	-	-	V
		I _O = 3 mA; V _{CCO} = 1.4 V	-	-	0.35	0.35	V
		I _O = 4.5 mA; V _{CCO} = 1.65 V	-	-	0.45	0.45	V
		I _O = 8 mA; V _{CCO} = 2.3 V	-	-	0.7	0.7	V
		I _O = 10 mA; V _{CCO} = 3.0 V	-	-	0.8	0.8	V
		I _O = 12 mA; V _{CCO} = 4.5 V	-	-	0.8	0.8	V
I _I	input leakage current	V _I = 0 V to 2.75 V; V _{CCI} = 0 V to 2.75 V ^[1]	-	±0.001	±0.1	±0.5	µA
I _{OZ}	OFF-state output current	V _O = 0 V to 5.5 V; V _{CCO} = 1.2 V to 5.5 V	-	±0.001	±0.1	±0.5	µA

Symbol	Parameter	Conditions	$T_{amb} = -40\text{ }^{\circ}\text{C to }+85\text{ }^{\circ}\text{C}$				Unit
			Min	Typ 25 °C	Max 25 °C	Max 85 °C	
I_{OFF}	power-off leakage current	inputs; $V_I = 0\text{ V to }2.75\text{ V}$; $V_{CCI} = 0\text{ V}$; $V_{CCO} = 0\text{ V to }5.5\text{ V}$ [1]	-	± 0.01	± 0.1	± 0.5	μA
		output; $V_O = 0\text{ V to }5.5\text{ V}$; $V_{CCO} = 0\text{ V}$; $V_{CCI} = 0\text{ V to }2.75\text{ V}$; $V_I = 0\text{ V to }2.75\text{ V}$ [1]	-	± 0.01	± 0.1	± 0.5	μA
ΔI_{OFF}	additional power-off leakage current	inputs; $V_I = 0\text{ V or }2.75\text{ V}$; $V_{CCI} = 0\text{ V to }0.1\text{ V}$; $V_{CCO} = 0\text{ V to }5.5\text{ V}$ [1]	-	± 0.02	± 0.1	± 0.5	μA
		output; $V_O = 0\text{ V or }5.5\text{ V}$; $V_{CCO} = 0\text{ V to }0.1\text{ V}$; $V_{CCI} = 0\text{ V to }2.75\text{ V}$; $V_I = 0\text{ V or }2.75\text{ V}$ [1]	-	± 0.02	± 0.1	± 0.5	μA

[1] Typical values are measured at $V_{CCI} = V_{CCO} = 1.2\text{ V}$ unless otherwise specified.

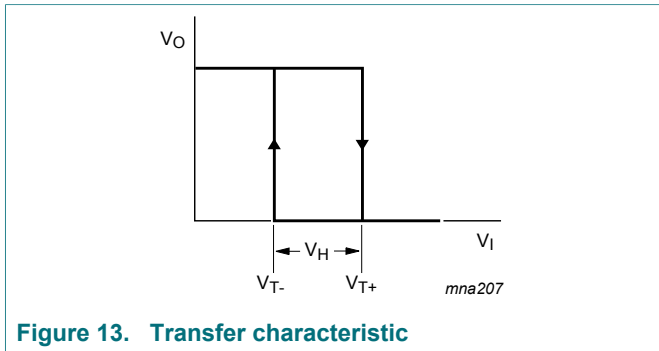

Figure 13. Transfer characteristic

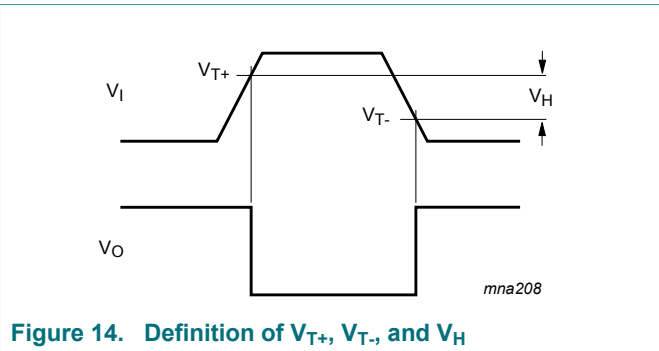

Figure 14. Definition of V_{T+} , V_{T-} , and V_H

Table 9. Static characteristics supply current

At recommended operating conditions, unless otherwise specified; voltages are referenced to GND (ground = 0 V).

Symbol	Parameter	Conditions	$T_{amb} = -40\text{ °C to }+85\text{ °C}$				Unit
			Typ 25 °C	Max 25 °C	Typ 85 °C	Max 85 °C	
I_{CCI}	input supply current	$V_I = 0\text{ V or }V_{CCI}$;					
		$V_{CCI} = 0.7\text{ V to }1.3\text{ V}$ ^[1]	1	100	10	300	nA
		$V_{CCI} = 1.3\text{ V to }2.75\text{ V}$ ^[2]	1	100	20	500	nA
		$V_{CCI} = 2.75\text{ V}; V_{CCO} = 0\text{ V}$	1	100	20	500	nA
		$V_{CCI} = 0\text{ V}; V_{CCO} = 5.5\text{ V}$	1	100	1	100	nA
I_{CCO}	output supply current	$V_I = 0\text{ V or }V_{CCI}$; $I_O = 0\text{ A}$; see Table 10					
		$V_{CCO} = 1.2\text{ V to }3.6\text{ V}$ ^[1]	0.001	1.0	0.01	1.2	μA
		$V_{CCO} = 3.6\text{ V to }5.5\text{ V}$ ^[3]	0.8	1.5	1.0	1.8	μA
		$V_{CCI} = 2.75\text{ V}; V_{CCO} = 0\text{ V}$	0.001	0.1	0.003	0.2	μA
		$V_{CCI} = 0\text{ V}; V_{CCO} = 3.6\text{ V}$	0.2	0.6	0.3	0.8	μA
		$V_{CCI} = 0\text{ V}; V_{CCO} = 5.5\text{ V}$	0.4	0.8	0.5	1.0	μA
ΔI_{CCI}	additional input supply current	$V_I = V_{CCI} - 0.5\text{ V}; V_{CCI} = 2.5\text{ V}$	2	100	14	150	μA

[1] Typical values are measured at $V_{CCI} = V_{CCO} = 1.2\text{ V}$ unless otherwise specified.

[2] Typical values are measured at $V_{CCI} = V_{CCO} = 2.5\text{ V}$.

[3] Typical values are measured at $V_{CCI} = 1.2\text{ V}$ and $V_{CCO} = 5.0\text{ V}$.

Table 10. Typical output supply current (I_{CCO})

V_{CCI}	V_{CCO}							Unit
	0 V	1.2 V	1.5 V	1.8 V	2.5 V	3.3 V	5.0 V	
0 V	0	1	5	20	100	200	400	nA
0.8 V	1	10	150	200	300	500	800	nA
1.2 V	1	1	5	200	300	500	800	nA
1.5 V	1	1	5	100	300	500	800	nA
1.8 V	1	1	5	100	300	500	800	nA
2.5 V	1	1	5	100	100	500	800	nA

11 Dynamic characteristics

Table 11. Dynamic characteristics

Voltages are referenced to GND (ground = 0 V); for test circuit, see [Figure 22](#); for waveform, see [Figure 15](#).

Symbol	Parameter	Conditions	V_{CCO}						Unit		
			1.2 V	1.5 V \pm 0.1 V		1.8 V \pm 0.15 V					
			Typ ^[1]	Min	Typ ^[1]	Max	Min	Typ ^[1]		Max	
$T_{amb} = 25\text{ }^{\circ}\text{C}$											
t_{pd}	propagation delay	A, B and C to Y ^[2]									
		$V_{CCI} = 0.75\text{ V to }0.85\text{ V}$	25	4	20	76	4	18	72	ns	
		$V_{CCI} = 1.1\text{ V to }1.3\text{ V}$	16.5	3.4	10.9	21.0	3.0	8.9	17.0	ns	
		$V_{CCI} = 1.4\text{ V to }1.6\text{ V}$	15.5	3.1	9.9	19.0	2.6	7.9	14.0	ns	
		$V_{CCI} = 1.65\text{ V to }1.95\text{ V}$	15.0	2.6	9.4	18.0	2.1	7.4	12.5	ns	
		$V_{CCI} = 2.3\text{ V to }2.7\text{ V}$	14.5	2.7	8.9	17.5	2.2	6.9	11.7	ns	
$T_{amb} = -40\text{ }^{\circ}\text{C to }+85\text{ }^{\circ}\text{C}$											
t_{pd}	propagation delay	A, B and C to Y ^[2]									
		$V_{CCI} = 0.75\text{ V to }0.85\text{ V}$	25	3	20	151	3	18	148	ns	
		$V_{CCI} = 1.1\text{ V to }1.3\text{ V}$	16.5	3.4	10.9	21.0	3.0	8.9	17.0	ns	
		$V_{CCI} = 1.4\text{ V to }1.6\text{ V}$	15.5	3.1	9.9	19.0	2.6	7.9	14.0	ns	
		$V_{CCI} = 1.65\text{ V to }1.95\text{ V}$	15.0	2.6	9.4	18.0	2.1	7.4	12.5	ns	
		$V_{CCI} = 2.3\text{ V to }2.7\text{ V}$	14.5	2.7	8.9	17.5	2.2	6.9	11.7	ns	
t_t	transition time	$V_{CCI} = 0.75\text{ V to }2.7\text{ V}$ ^[3]	-	1.0	-	-	1.0	-	-	ns	

[1] Typical values are measured at nominal supply voltages and $T_{amb} = +25\text{ }^{\circ}\text{C}$.

[2] t_{pd} is the same as t_{PLH} and t_{PHL} .

[3] t_t is the same as t_{THL} and t_{TLH} .

Table 12. Dynamic characteristics

Voltages are referenced to GND (ground = 0 V); for test circuit, see Figure 22; for waveform, see Figure 15.

Symbol	Parameter	Conditions	V _{CCO}									Unit
			2.5 V ± 0.2 V			3.3 V ± 0.3 V			5.0 V ± 0.5 V			
			Min	Typ ^[1]	Max	Min	Typ ^[1]	Max	Min	Typ ^[1]	Max	
T _{amb} = 25 °C												
t _{pd}	propagation delay	A, B and C to Y ^[2]										
		V _{CCI} = 0.75 V to 0.85 V	3	16	72	3	16	80	3	17	92	ns
		V _{CCI} = 1.1 V to 1.3 V	2.6	7.3	12.0	2.5	6.7	10.7	2.4	6.4	10.2	ns
		V _{CCI} = 1.4 V to 1.6 V	2.3	6.2	9.9	2.1	5.6	9.0	2.1	5.3	8.5	ns
		V _{CCI} = 1.65 V to 1.95 V	1.7	5.7	9.3	1.6	5.1	8.3	1.5	4.8	7.9	ns
		V _{CCI} = 2.3 V to 2.7 V	1.9	5.2	8.7	1.8	4.6	7.7	1.7	4.3	7.2	ns
T _{amb} = -40 °C to +85 °C												
t _{pd}	propagation delay	A, B and C to Y ^[2]										
		V _{CCI} = 0.75 V to 0.85 V	2	16	167	2	16	194	2	17	225	ns
		V _{CCI} = 1.1 V to 1.3 V	2.6	7.3	12.0	2.5	6.7	10.7	2.4	6.4	10.2	ns
		V _{CCI} = 1.4 V to 1.6 V	2.3	6.2	9.9	2.1	5.6	9.0	2.1	5.3	8.5	ns
		V _{CCI} = 1.65 V to 1.95 V	1.7	5.7	9.3	1.6	5.1	8.3	1.5	4.8	7.9	ns
		V _{CCI} = 2.3 V to 2.7 V	1.9	5.2	8.7	1.8	4.6	7.7	1.7	4.3	7.2	ns
t _t	transition time	V _{CCI} = 0.75 V to 2.7 V ^[3]	1.0	-	-	1.0	-	-	1.0	-	-	ns

[1] Typical values are measured at nominal supply voltages and t_{amb} = +25 °C.

[2] t_{pd} is the same as t_{PLH} and t_{PHL}.

[3] t_t is the same as t_{THL} and t_{TLH}.

Table 13. Typical dynamic characteristics at $T_{amb} = 25\text{ }^{\circ}\text{C}$

Voltages are referenced to GND (ground = 0 V); for test circuit, see [Figure 22](#); for waveform, see [Figure 15](#).

Symbol	Parameter	Conditions	V_{CCO}						Unit	
			1.2 V	1.5 V	1.8 V	2.5 V	3.3 V	5.0 V		
C_{PD}	power dissipation capacitance	$f_i = 1\text{ MHz}; R_L = \infty\ \Omega; V_I = 0\text{ V to }V_{CCI}$ [1]								
		input supply [2]								
		$V_{CCI} = 0.8\text{ V}$	0.5	0.5	0.5	0.5	0.5	0.5	pF	
		$V_{CCI} = 1.2\text{ V}$	0.6	0.6	0.6	0.6	0.6	0.6	pF	
		$V_{CCI} = 1.5\text{ V}$	0.7	0.7	0.7	0.7	0.7	0.7	pF	
		$V_{CCI} = 1.8\text{ V}$	0.8	0.8	0.8	0.8	0.8	0.8	pF	
		$V_{CCI} = 2.5\text{ V}$	1.0	1.0	1.0	1.0	1.0	1.0	pF	
		output supply [3]								
		$V_{CCI} = 0.8\text{ V}$	6.7	6.8	6.8	6.9	7.5	9.5	pF	
		$V_{CCI} = 1.2\text{ V}$	6.8	6.9	7.0	7.0	7.1	7.6	pF	
		$V_{CCI} = 1.5\text{ V}$	6.9	6.9	6.9	7.0	7.1	7.6	pF	
		$V_{CCI} = 1.8\text{ V}$	6.9	6.9	6.9	7.0	7.2	7.6	pF	
$V_{CCI} = 2.5\text{ V}$	6.9	7.0	7.0	7.0	7.2	7.6	pF			
C_I	input capacitance	$V_I = 0\text{ V or }V_{CCI}; V_{CCI} = 0\text{ V to }2.7\text{ V}$	0.6	0.6	0.6	0.6	0.6	0.6	pF	
C_O	output capacitance	$V_O = 0\text{ V}; V_{CCO} = 0\text{ V}$	1.8	1.8	1.8	1.8	1.8	1.8	pF	

[1] C_{PD} is used to determine the dynamic power dissipation (P_D in μW).

[2] Power dissipated from input supply (V_{CCI})

$$P_D = C_{PD} \times V_{CCI}^2 \times f_i \times N \text{ where:}$$

C_{PD} = power dissipation capacitance of the input supply.

V_{CCI} = input supply voltage in V;

f_i = input frequency in MHz;

N = number of inputs switching;

[3] Power dissipated from output supply (V_{CCO})

$$P_D = (C_L + C_{PD}) \times V_{CCO}^2 \times f_o \text{ where:}$$

C_L = load capacitance in pF;

C_{PD} = power dissipation capacitance of the output supply.

V_{CCO} = output supply voltage in V;

f_o = output frequency in MHz;

11.1 Waveforms and graphs

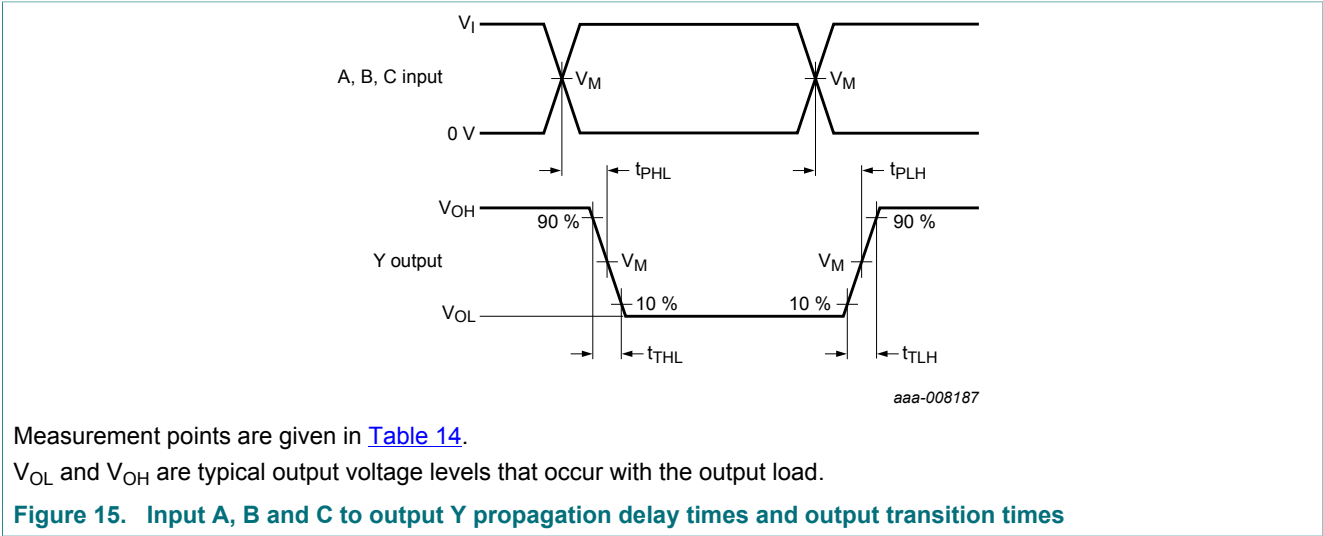

Measurement points are given in [Table 14](#).

V_{OL} and V_{OH} are typical output voltage levels that occur with the output load.

Figure 15. Input A, B and C to output Y propagation delay times and output transition times

Table 14. Measurement points

Supply voltage		Output	Input	
V_{CCI}	V_{CCO}	V_M	V_M	V_I
0.75 V to 2.7 V	1.2 V to 5.5 V	$0.5V_{CCO}$	$0.5V_{CCI}$	V_{CCI}

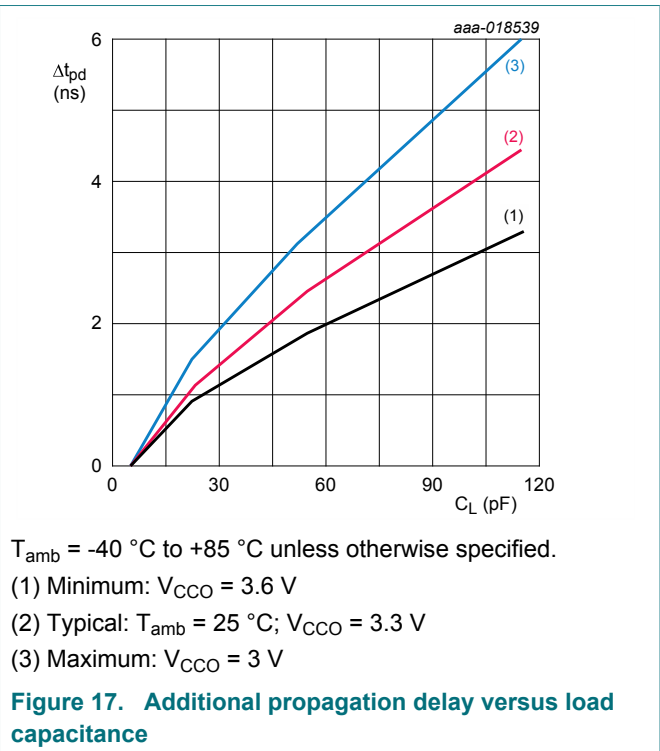
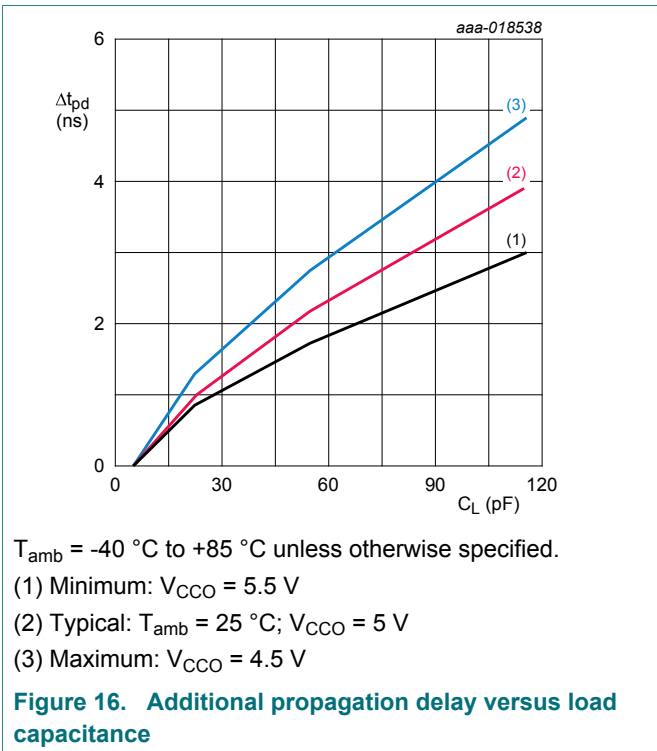

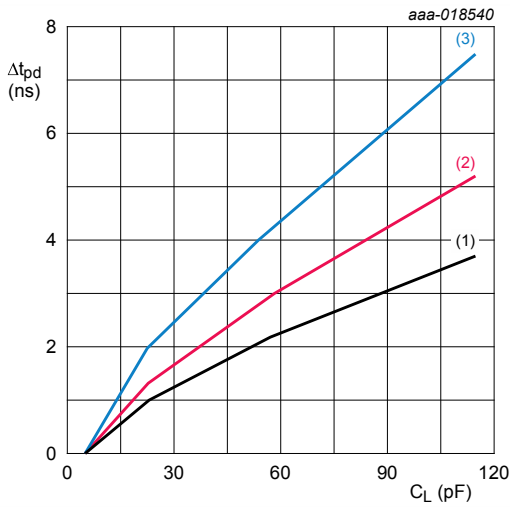

$T_{amb} = -40\text{ }^{\circ}\text{C}$ to $+85\text{ }^{\circ}\text{C}$ unless otherwise specified.
 (1) Minimum: $V_{CC0} = 2.7\text{ V}$
 (2) Typical: $T_{amb} = 25\text{ }^{\circ}\text{C}$; $V_{CC0} = 2.5\text{ V}$
 (3) Maximum: $V_{CC0} = 2.3\text{ V}$

Figure 18. Additional propagation delay versus load capacitance



$T_{amb} = -40\text{ }^{\circ}\text{C}$ to $+85\text{ }^{\circ}\text{C}$ unless otherwise specified.
 (1) Minimum: $V_{CC0} = 1.95\text{ V}$
 (2) Typical: $T_{amb} = 25\text{ }^{\circ}\text{C}$; $V_{CC0} = 1.8\text{ V}$
 (3) Maximum: $V_{CC0} = 1.65\text{ V}$

Figure 19. Additional propagation delay versus load capacitance

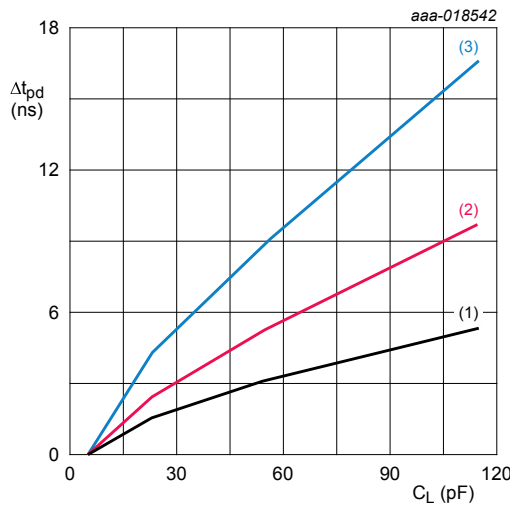

$T_{amb} = -40\text{ }^{\circ}\text{C}$ to $+85\text{ }^{\circ}\text{C}$ unless otherwise specified.
 (1) Minimum: $V_{CC0} = 1.6\text{ V}$
 (2) Typical: $T_{amb} = 25\text{ }^{\circ}\text{C}$; $V_{CC0} = 1.5\text{ V}$
 (3) Maximum: $V_{CC0} = 1.4\text{ V}$

Figure 20. Additional propagation delay versus load capacitance

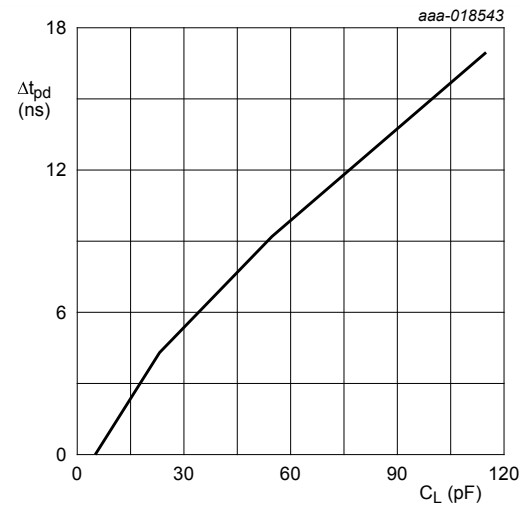

$T_{amb} = 25\text{ }^{\circ}\text{C}$; $V_{CC0} = 1.2\text{ V}$.

Figure 21. Additional propagation delay versus load capacitance



Table 15. Test data

Supply voltage		Load		Input	
V_{CCI}	V_{CCO}	C_L	R_L	t_r, t_f	V_I
0.75 V to 2.7 V	1.2 V to 5.5 V	5 pF	5 kΩ	≤3.0 ns	V_{CCI}

12 Package outline

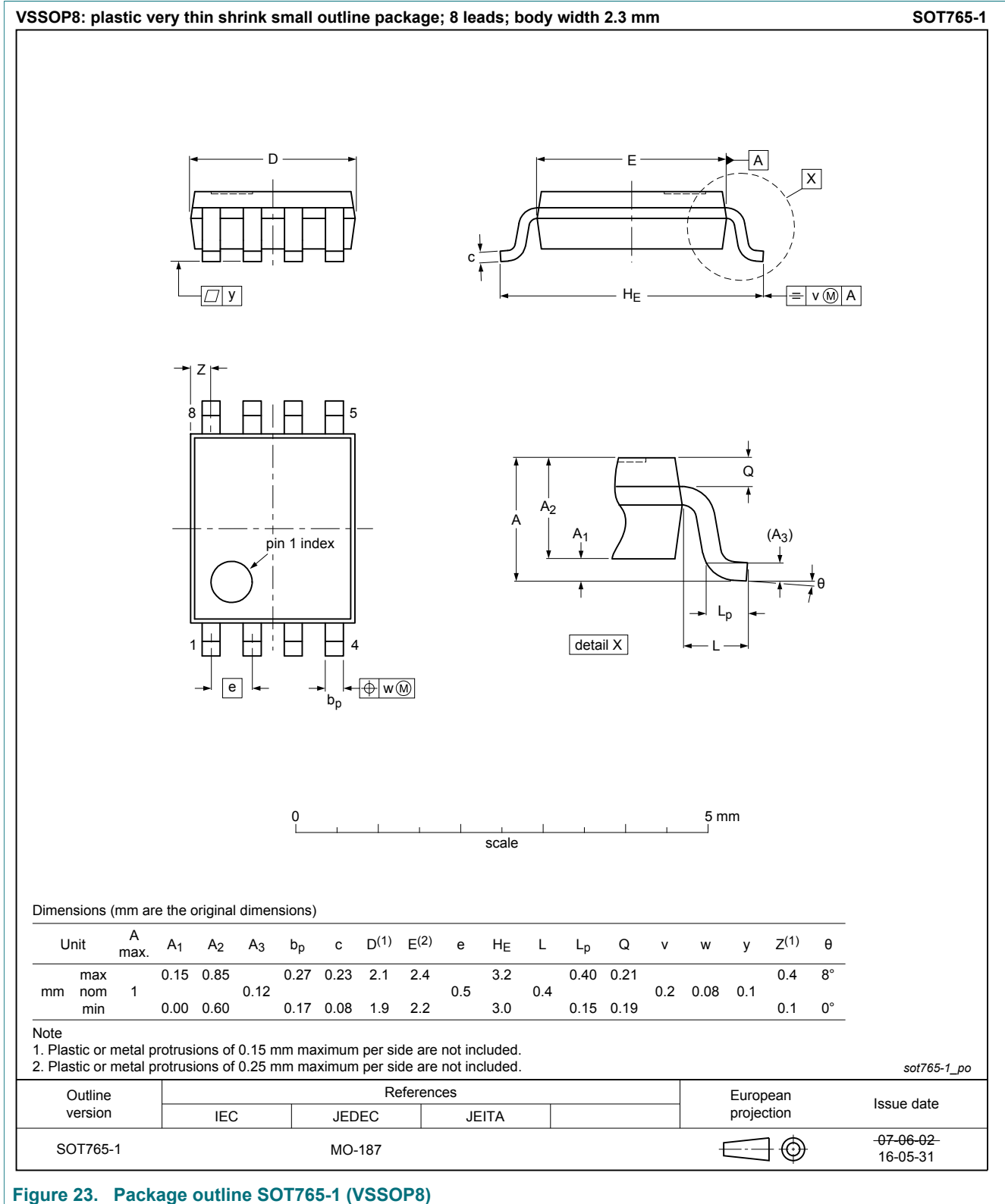
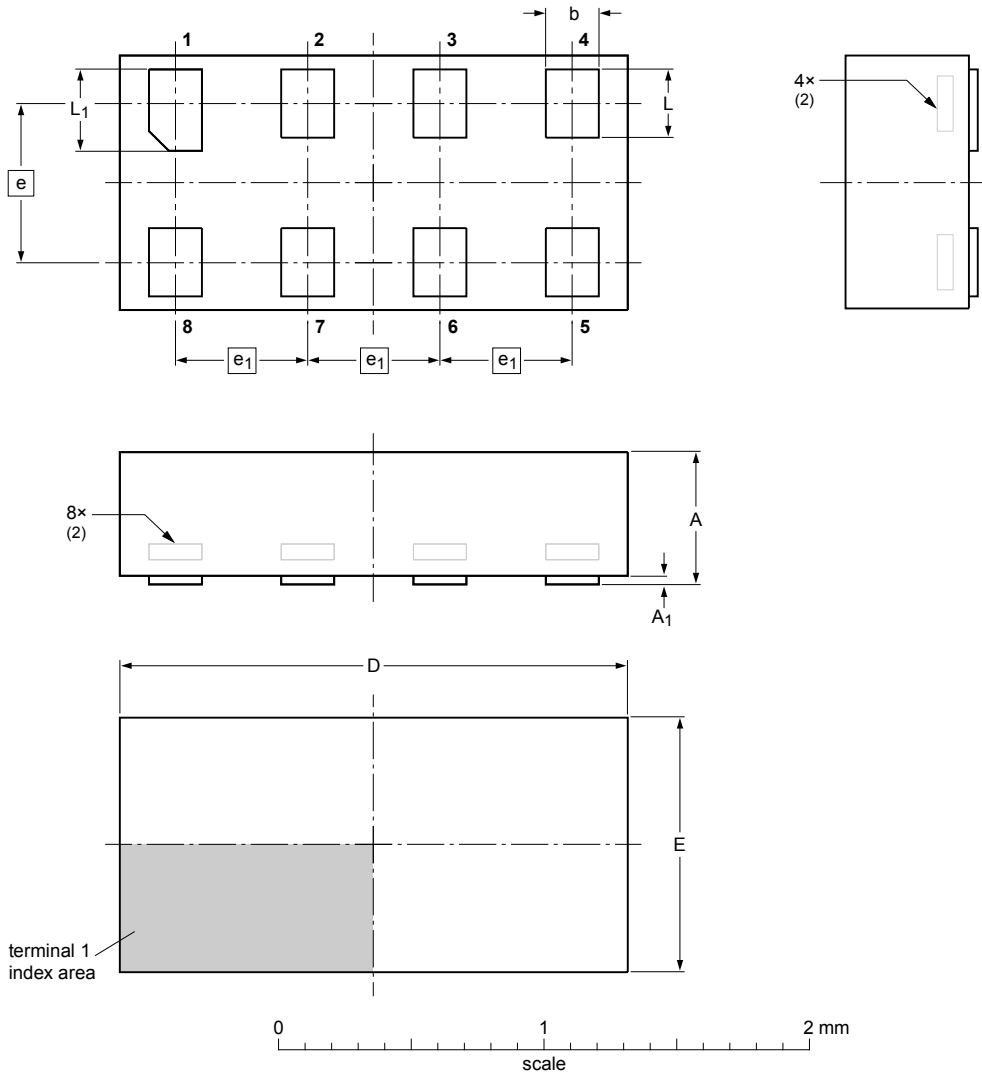

Figure 23. Package outline SOT765-1 (VSSOP8)

XSON8: plastic extremely thin small outline package; no leads; 8 terminals; body 1 x 1.95 x 0.5 mm

SOT833-1



DIMENSIONS (mm are the original dimensions)

UNIT	A ⁽¹⁾ max	A ₁ max	b	D	E	e	e ₁	L	L ₁
mm	0.5	0.04	0.25 0.17	2.0 1.9	1.05 0.95	0.6	0.5	0.35 0.27	0.40 0.32

Notes

1. Including plating thickness.
2. Can be visible in some manufacturing processes.

OUTLINE VERSION	REFERENCES			EUROPEAN PROJECTION	ISSUE DATE
	IEC	JEDEC	JEITA		
SOT833-1	---	MO-252	---		07-11-14 07-12-07

Figure 24. Package outline SOT833-1 (XSON8)

XSON8: extremely thin small outline package; no leads;
8 terminals; body 1.2 x 1.0 x 0.35 mm

SOT1116

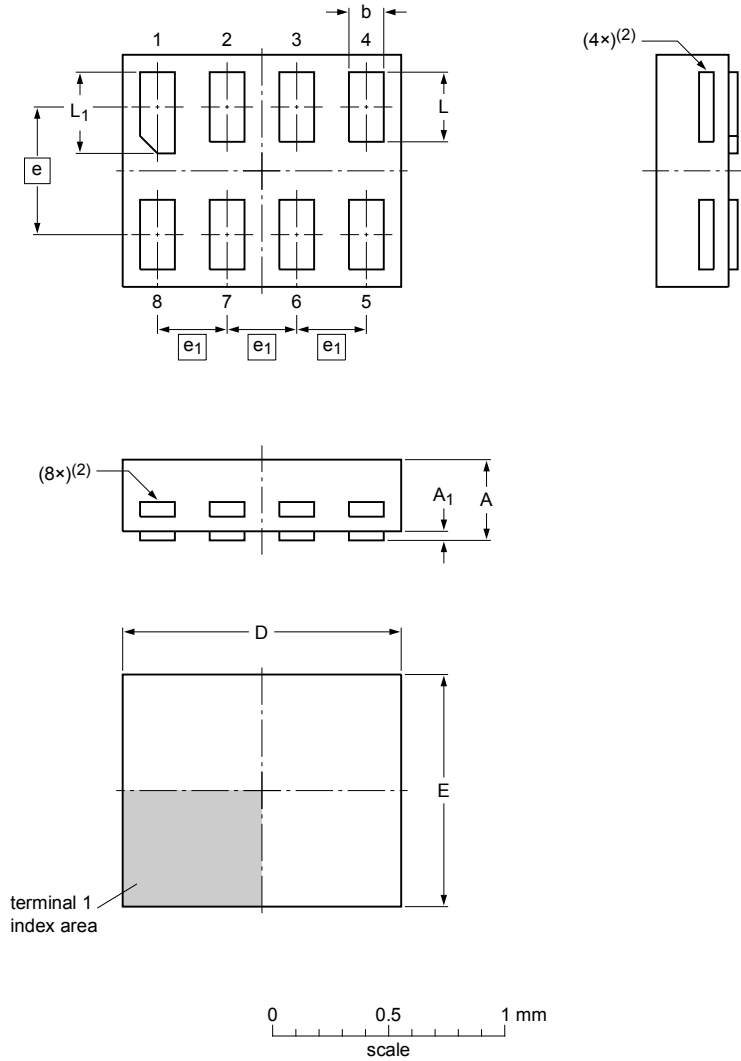

Dimensions

Unit	A ⁽¹⁾	A ₁	b	D	E	e	e ₁	L	L ₁
max	0.35	0.04	0.20	1.25	1.05			0.35	0.40
nom			0.15	1.20	1.00	0.55	0.3	0.30	0.35
min			0.12	1.15	0.95			0.27	0.32

Note

- Including plating thickness.
- Visible depending upon used manufacturing technology.

sot1116_po

Outline version	References				European projection	Issue date
	IEC	JEDEC	JEITA			
SOT1116						-10-04-02- 10-04-07

Figure 25. Package outline SOT1116 (XSON8)

XSON8: extremely thin small outline package; no leads;
8 terminals; body 1.35 x 1.0 x 0.35 mm

SOT1203

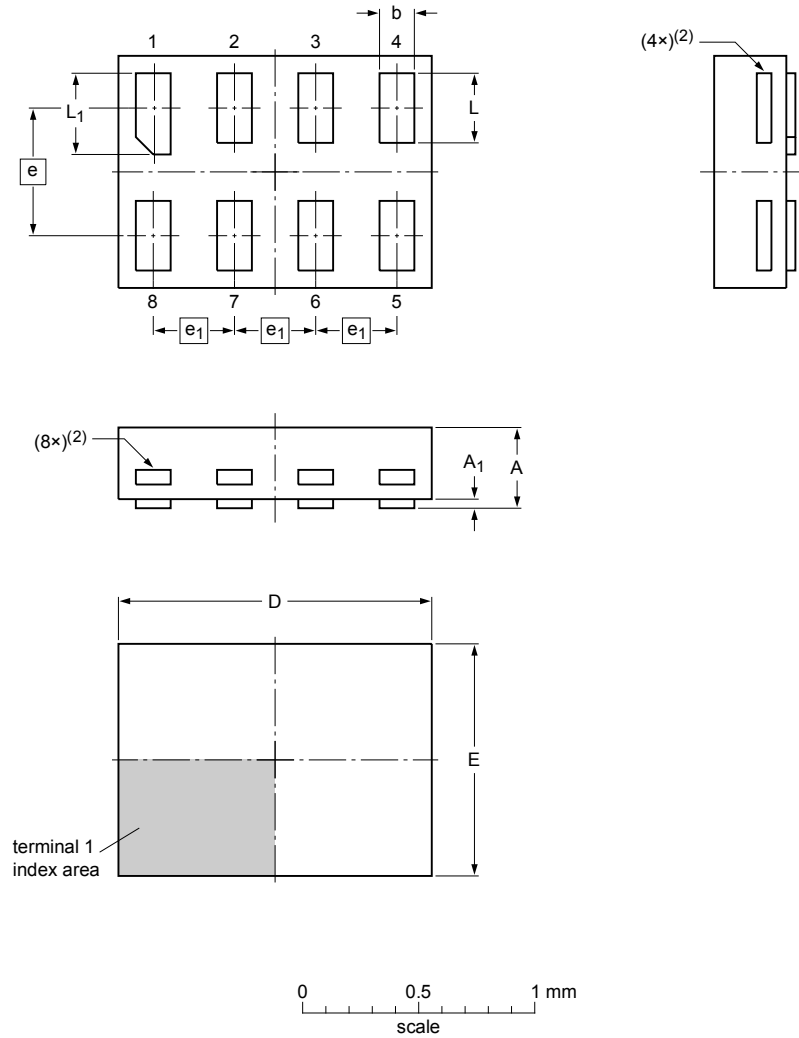

Dimensions

Unit	A ⁽¹⁾	A ₁	b	D	E	e	e ₁	L	L ₁
mm	max 0.35	0.04	0.20	1.40	1.05			0.35	0.40
	nom 0.15	1.35	1.00	0.55	0.35	0.30	0.35		
	min 0.12	1.30	0.95			0.27	0.32		

Note

- Including plating thickness.
- Visible depending upon used manufacturing technology.

sot1203_po

Outline version	References				European projection	Issue date
	IEC	JEDEC	JEITA			
SOT1203						-10-04-02- 10-04-06

Figure 26. Package outline SOT1203 (XSON8)

X2SON8: plastic thermal enhanced extremely thin small outline package; no leads; 8 terminals; body 1.35 x 0.8 x 0.35 mm

SOT1233

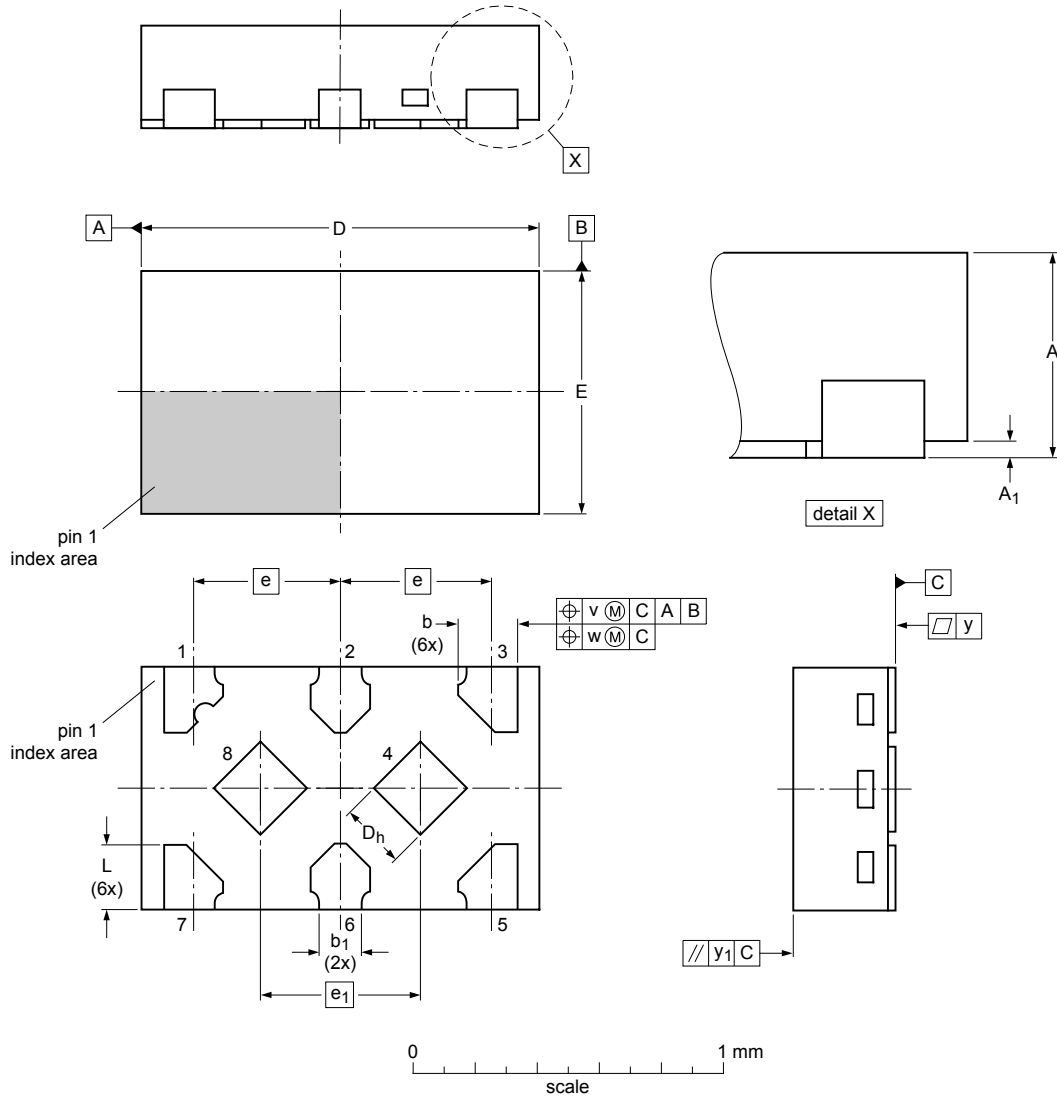

Dimensions (mm are the original dimensions)

Unit	A	A ₁	b	b ₁	D	D _h	E	e	e ₁	L	v	w	y	y ₁
max	0.35	0.04	0.25		1.40	0.27	0.85			0.27				
nom	0.32		0.20	0.15	1.35	0.22	0.80	0.5	0.54	0.22	0.1	0.05	0.05	0.05
min	0.30	0.00	0.15	(ref)	1.30	0.17	0.75			0.17				

sot1233_po

Outline version	References				European projection	Issue date
	IEC	JEDEC	JEITA			
SOT1233		---				16-04-21 17-01-05

Figure 27. Package outline SOT1233 (X2SON8)

13 Abbreviations

Table 16. Abbreviations

Acronym	Description
CDM	Charged Device Model
DUT	Device Under Test
ESD	ElectroStatic Discharge
HBM	Human Body Model

14 Revision history

Table 17. Revision history

Document ID	Release date	Data sheet status	Change notice	Supersedes
74AXP1T57 v.5	20170703	Product data sheet	-	74AXP1T57 v.4
Modifications:	<ul style="list-style-type: none"> • Figure 27: Package outline drawing for SOT1233 / X2SON8) has changed. 			
74AXP1T57 v.4	20161028	Product data sheet	-	74AXP1T57 v.3
Modifications:	<ul style="list-style-type: none"> • Added type number 74AXP1T57GX (SOT1233/X2SON8) 			
74AXP1T57 v.3	20161007	Product data sheet	-	74AXP1T57 v.2
Modifications:	<ul style="list-style-type: none"> • Type numbers 74AXP1T57DP and 74AXP1T57GD removed. 			
74AXP1T57 v.2	20151222	Product data sheet	-	74AXP1T57 v.1
Modifications:	<ul style="list-style-type: none"> • Table 6: Conditions V_O corrected (errata). • Table 6: Derating values for packages added (errata). • Table 7: Conditions V_O corrected (errata). • Table 8: Conditions I_{OZ} corrected (errata). • Table 9: Conditions ΔI_{CCI} corrected (errata). • Table 11 and Table 12: Conditions t_r corrected (errata). • Table 11: Conditions t_r corrected (errata). • Table 13: Removed "leadless packages" from conditions (errata). 			
74AXP1T57 v.1	20150803	Product data sheet	-	-

15 Legal information

15.1 Data sheet status

Document status ^{[1][2]}	Product status ^[3]	Definition
Objective [short] data sheet	Development	This document contains data from the objective specification for product development.
Preliminary [short] data sheet	Qualification	This document contains data from the preliminary specification.
Product [short] data sheet	Production	This document contains the product specification.

[1] Please consult the most recently issued document before initiating or completing a design.

[2] The term 'short data sheet' is explained in section "Definitions".

[3] The product status of device(s) described in this document may have changed since this document was published and may differ in case of multiple devices. The latest product status information is available on the Internet at URL <http://www.nexperia.com>.

15.2 Definitions

Draft — The document is a draft version only. The content is still under internal review and subject to formal approval, which may result in modifications or additions. Nexperia does not give any representations or warranties as to the accuracy or completeness of information included herein and shall have no liability for the consequences of use of such information.

Short data sheet — A short data sheet is an extract from a full data sheet with the same product type number(s) and title. A short data sheet is intended for quick reference only and should not be relied upon to contain detailed and full information. For detailed and full information see the relevant full data sheet, which is available on request via the local Nexperia sales office. In case of any inconsistency or conflict with the short data sheet, the full data sheet shall prevail.

Product specification — The information and data provided in a Product data sheet shall define the specification of the product as agreed between Nexperia and its customer, unless Nexperia and customer have explicitly agreed otherwise in writing. In no event however, shall an agreement be valid in which the Nexperia product is deemed to offer functions and qualities beyond those described in the Product data sheet.

15.3 Disclaimers

Limited warranty and liability — Information in this document is believed to be accurate and reliable. However, Nexperia does not give any representations or warranties, expressed or implied, as to the accuracy or completeness of such information and shall have no liability for the consequences of use of such information. Nexperia takes no responsibility for the content in this document if provided by an information source outside of Nexperia. In no event shall Nexperia be liable for any indirect, incidental, punitive, special or consequential damages (including - without limitation - lost profits, lost savings, business interruption, costs related to the removal or replacement of any products or rework charges) whether or not such damages are based on tort (including negligence), warranty, breach of contract or any other legal theory. Notwithstanding any damages that customer might incur for any reason whatsoever, Nexperia's aggregate and cumulative liability towards customer for the products described herein shall be limited in accordance with the Terms and conditions of commercial sale of Nexperia.

Right to make changes — Nexperia reserves the right to make changes to information published in this document, including without limitation specifications and product descriptions, at any time and without notice. This document supersedes and replaces all information supplied prior to the publication hereof.

Suitability for use — Nexperia products are not designed, authorized or warranted to be suitable for use in life support, life-critical or safety-critical

systems or equipment, nor in applications where failure or malfunction of an Nexperia product can reasonably be expected to result in personal injury, death or severe property or environmental damage. Nexperia and its suppliers accept no liability for inclusion and/or use of Nexperia products in such equipment or applications and therefore such inclusion and/or use is at the customer's own risk.

Applications — Applications that are described herein for any of these products are for illustrative purposes only. Nexperia makes no representation or warranty that such applications will be suitable for the specified use without further testing or modification. Customers are responsible for the design and operation of their applications and products using Nexperia products, and Nexperia accepts no liability for any assistance with applications or customer product design. It is customer's sole responsibility to determine whether the Nexperia product is suitable and fit for the customer's applications and products planned, as well as for the planned application and use of customer's third party customer(s). Customers should provide appropriate design and operating safeguards to minimize the risks associated with their applications and products. Nexperia does not accept any liability related to any default, damage, costs or problem which is based on any weakness or default in the customer's applications or products, or the application or use by customer's third party customer(s). Customer is responsible for doing all necessary testing for the customer's applications and products using Nexperia products in order to avoid a default of the applications and the products or of the application or use by customer's third party customer(s). Nexperia does not accept any liability in this respect.

Limiting values — Stress above one or more limiting values (as defined in the Absolute Maximum Ratings System of IEC 60134) will cause permanent damage to the device. Limiting values are stress ratings only and (proper) operation of the device at these or any other conditions above those given in the Recommended operating conditions section (if present) or the Characteristics sections of this document is not warranted. Constant or repeated exposure to limiting values will permanently and irreversibly affect the quality and reliability of the device.

Terms and conditions of commercial sale — Nexperia products are sold subject to the general terms and conditions of commercial sale, as published at <http://www.nexperia.com/profile/terms>, unless otherwise agreed in a valid written individual agreement. In case an individual agreement is concluded only the terms and conditions of the respective agreement shall apply. Nexperia hereby expressly objects to applying the customer's general terms and conditions with regard to the purchase of Nexperia products by customer.

No offer to sell or license — Nothing in this document may be interpreted or construed as an offer to sell products that is open for acceptance or the grant, conveyance or implication of any license under any copyrights, patents or other industrial or intellectual property rights.

Export control — This document as well as the item(s) described herein may be subject to export control regulations. Export might require a prior authorization from competent authorities.

Non-automotive qualified products — Unless this data sheet expressly states that this specific Nexperia product is automotive qualified, the product is not suitable for automotive use. It is neither qualified nor tested in accordance with automotive testing or application requirements. Nexperia accepts no liability for inclusion and/or use of non-automotive qualified products in automotive equipment or applications. In the event that customer uses the product for design-in and use in automotive applications to automotive specifications and standards, customer (a) shall use the product without Nexperia's warranty of the product for such automotive applications, use and specifications, and (b) whenever customer uses the product for automotive applications beyond Nexperia's specifications such use shall be solely at customer's own risk, and (c) customer fully indemnifies Nexperia for any liability, damages or failed product claims resulting from customer

design and use of the product for automotive applications beyond Nexperia's standard warranty and Nexperia's product specifications.

Translations — A non-English (translated) version of a document is for reference only. The English version shall prevail in case of any discrepancy between the translated and English versions.

15.4 Trademarks

Notice: All referenced brands, product names, service names and trademarks are the property of their respective owners.

Contents

1	General description	1
2	Features and benefits	1
3	Ordering information	2
4	Marking	2
5	Functional diagram	2
6	Pinning information	3
6.1	Pinning	3
6.2	Pin description	3
7	Functional description	4
7.1	Logic configurations	4
8	Limiting values	6
9	Recommended operating conditions	6
10	Static characteristics	7
11	Dynamic characteristics	10
11.1	Waveforms and graphs	13
12	Package outline	16
13	Abbreviations	21
14	Revision history	21
15	Legal information	22

Please be aware that important notices concerning this document and the product(s) described herein, have been included in section 'Legal information'.

© Nexperia B.V. 2017.

All rights reserved.

For more information, please visit: <http://www.nexperia.com>

For sales office addresses, please send an email to: salesaddresses@nexperia.com

Date of release: 3 July 2017
Document identifier: 74AXP1T57



Стандарт Электрон Связь

Мы молодая и активно развивающаяся компания в области поставок электронных компонентов. Мы поставляем электронные компоненты отечественного и импортного производства напрямую от производителей и с крупнейших складов мира.

Благодаря сотрудничеству с мировыми поставщиками мы осуществляем комплексные и плановые поставки широчайшего спектра электронных компонентов.

Собственная эффективная логистика и склад в обеспечивает надежную поставку продукции в точно указанные сроки по всей России.

Мы осуществляем техническую поддержку нашим клиентам и предпродажную проверку качества продукции. На все поставляемые продукты мы предоставляем гарантию .

Осуществляем поставки продукции под контролем ВП МО РФ на предприятия военно-промышленного комплекса России , а также работаем в рамках 275 ФЗ с открытием отдельных счетов в уполномоченном банке. Система менеджмента качества компании соответствует требованиям ГОСТ ISO 9001.

Минимальные сроки поставки, гибкие цены, неограниченный ассортимент и индивидуальный подход к клиентам являются основой для выстраивания долгосрочного и эффективного сотрудничества с предприятиями радиоэлектронной промышленности, предприятиями ВПК и научно-исследовательскими институтами России.

С нами вы становитесь еще успешнее!

Наши контакты:

Телефон: +7 812 627 14 35

Электронная почта: sales@st-electron.ru

Адрес: 198099, Санкт-Петербург,
Промышленная ул, дом № 19, литера Н,
помещение 100-Н Офис 331