

Analog Devices Welcomes Hittite Microwave Corporation

NO CONTENT ON THE ATTACHED DOCUMENT HAS CHANGED



THIS PAGE INTENTIONALLY LEFT BLANK

GaAs PHEMT MMIC LOW NOISE AMPLIFIER, 18 - 31 GHz

Typical Applications

The HMC519LC4 is ideal for:

- Point-to-Point Radios
- Point-to-Multi-Point Radios & VSAT
- Test Equipment & Sensors
- Military & Space

Features

- Noise Figure: 3.5 dB
- Gain: 14 dB
- Output IP3: +23 dBm
- Single Supply: +3V @ 75 mA
- 50 Ohm Matched Input/Output
- 24 Lead Ceramic 4x4mm SMT Package: 16mm²

Functional Diagram

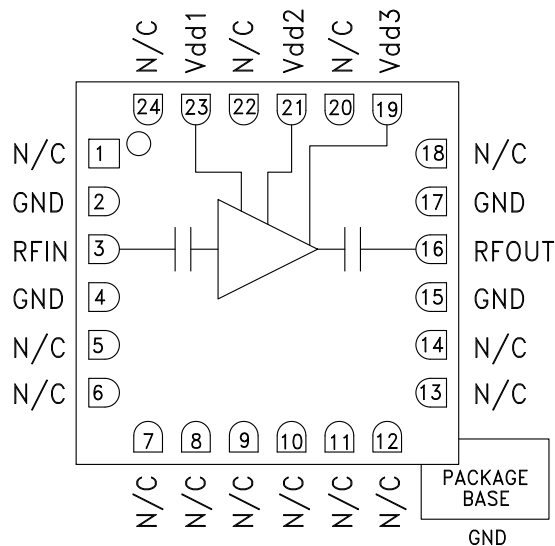

General Description

The HMC519LC4 is a high dynamic range GaAs pHEMT MMIC Low Noise Amplifier (LNA) housed in a leadless 4 x 4 mm ceramic surface mount package. The amplifier operates between 18 and 31 GHz, providing 14 dB of small signal gain, 3.5 dB noise figure and output IP3 of +23 dBm, while requiring only 75 mA from a +3V single supply. The P1dB output power of +11 dBm, enables the LNA to function as a LO driver for balanced, I/Q or image reject mixers. The HMC519LC4 also features I/Os that are DC blocked and internally matched to 50 Ohms, making it ideal for microwave radio and VSAT applications.

Electrical Specifications, $T_A = +25^\circ\text{C}$, $V_{dd\ 1, 2, 3} = +3V$

| Parameter | Min. | Typ. | Max. | Min. | Typ. | Max. | Units |
|--|---------|-------|---------|------|-------|-------|-------|
| Frequency Range | 18 - 28 | | 28 - 31 | | | | GHz |
| Gain | 11.4 | 14.4 | | 10.2 | 13.2 | | dB |
| Gain Variation Over Temperature | | 0.016 | 0.026 | | 0.016 | 0.026 | dB/°C |
| Noise Figure | | 3.5 | 5.5 | | 3 | 5 | dB |
| Input Return Loss | | 15 | | | 17 | | dB |
| Output Return Loss | | 20 | | | 22 | | dB |
| Output Power for 1 dB Compression (P1dB) | 8 | 11 | | 9.2 | 12.2 | | dBm |
| Saturated Output Power (P _{sat}) | | 14 | | | 15.4 | | dBm |
| Output Third Order Intercept (IP3) | | 23 | | | 24 | | dBm |
| Supply Current (I _{dd}) | | 75 | 95 | | 75 | 95 | mA |



**GaAs PHEMT MMIC LOW NOISE
 AMPLIFIER, 18 - 31 GHz**

Broadband Gain & Return Loss

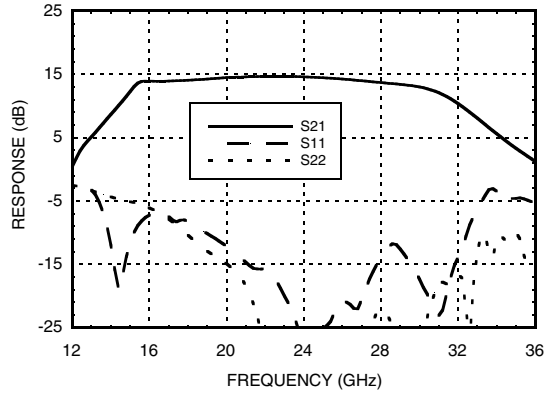

Gain vs. Temperature

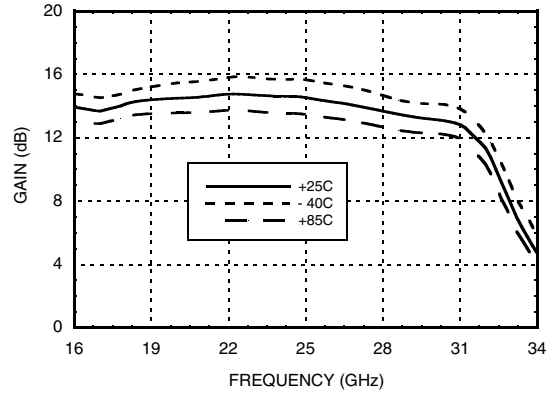

Input Return Loss vs. Temperature

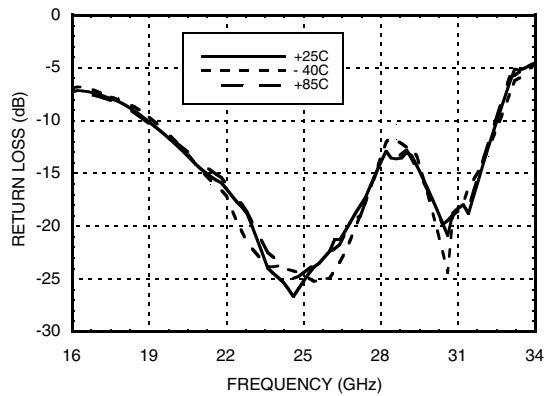

Output Return Loss vs. Temperature

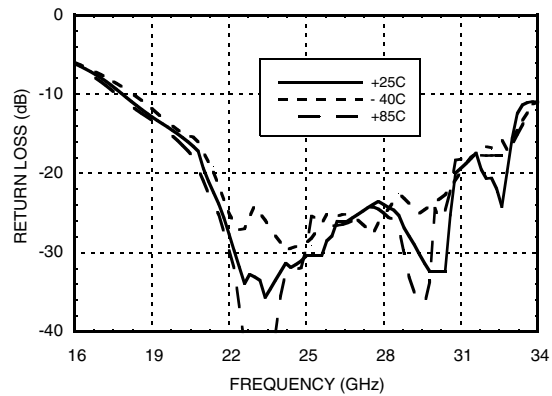

Noise Figure vs. Temperature

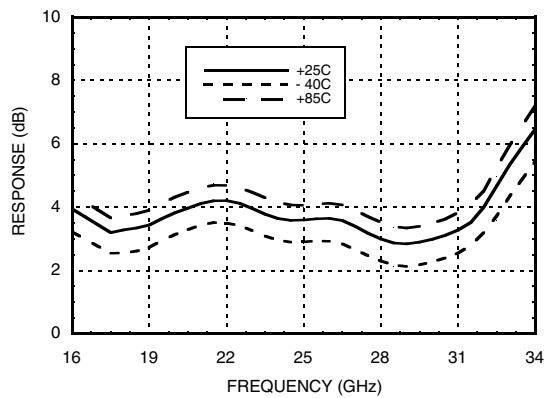

Output IP3 vs. Temperature

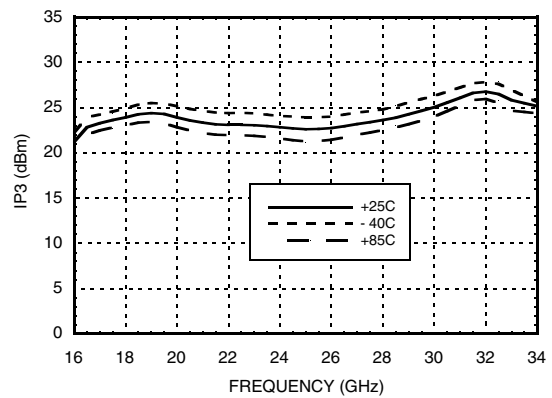

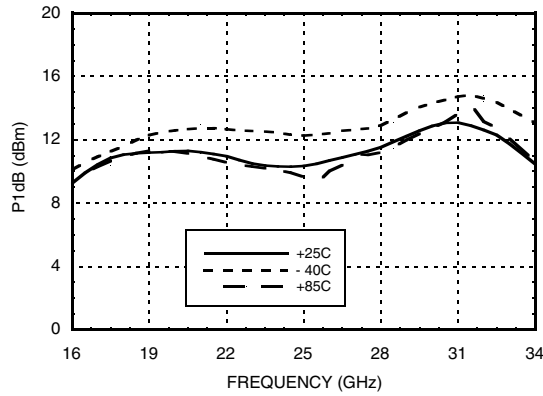
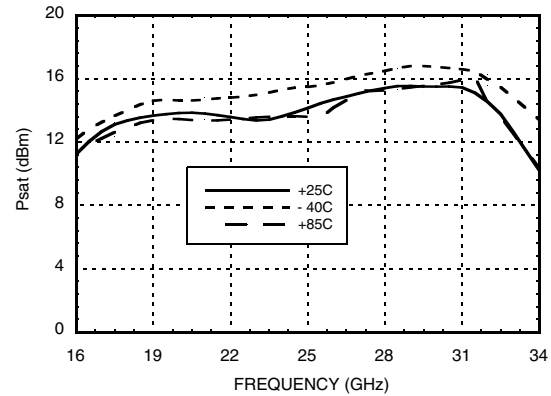
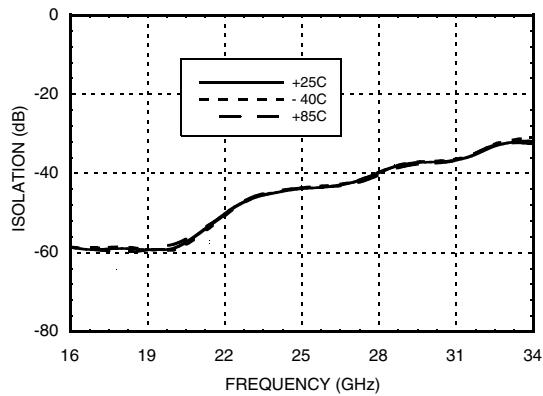
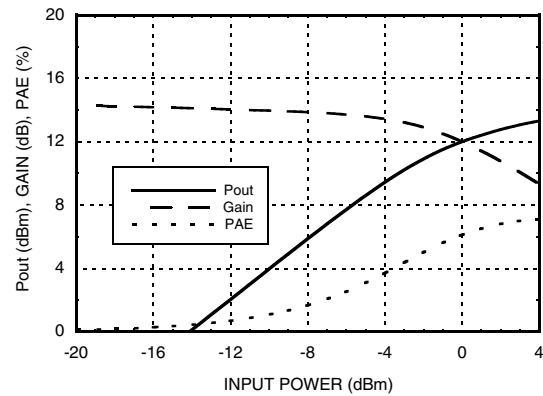
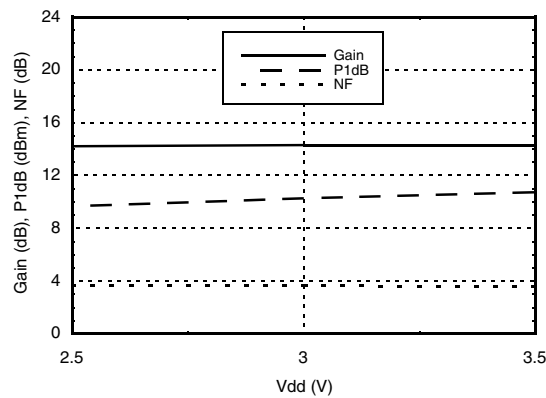
**GaAs PHEMT MMIC LOW NOISE
AMPLIFIER, 18 - 31 GHz**
P1dB vs. Temperature

Psat vs. Temperature

Reverse Isolation vs. Temperature

Power Compression @ 24 GHz

**Gain, Noise Figure & Power vs.
Supply Voltage @ 24 GHz**

**GaAs PHEMT MMIC LOW NOISE
AMPLIFIER, 18 - 31 GHz**
Absolute Maximum Ratings

| | |
|--|---------------|
| Drain Bias Voltage (Vdd1, Vdd2, Vdd3) | +3.5 Vdc |
| RF Input Power (RFIN)(Vdd = +3.0 Vdc) | +8 dBm |
| Channel Temperature | 175 °C |
| Continuous Pdiss (T= 85 °C) (derate 12 mW/°C above 85 °C) | 1.08 W |
| Thermal Resistance (channel to package bottom) | 83 °C/W |
| Storage Temperature | -65 to 150 °C |
| Operating Temperature | -40 to 85 °C |
| ESD Sensitivity (HBM) | Class 1B |

Typical Supply Current vs. Vdd

| Vdd (V) | Idd (mA) |
|---------|----------|
| 2.5 | 72 |
| 3.0 | 75 |
| 3.5 | 78 |

Note: Amplifier will operate over full voltage ranges shown above.

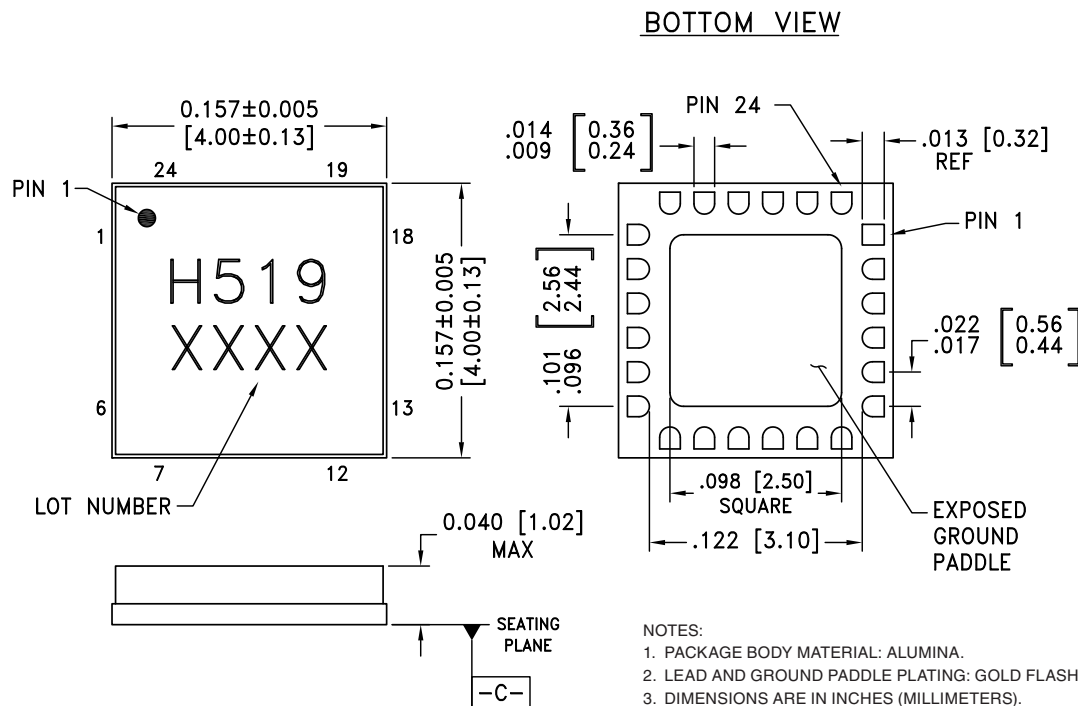

**ELECTROSTATIC SENSITIVE DEVICE
OBSERVE HANDLING PRECAUTIONS**

Outline Drawing

NOTES:

- PACKAGE BODY MATERIAL: ALUMINA.
- LEAD AND GROUND PADDLE PLATING: GOLD FLASH OVER NICKEL.
- DIMENSIONS ARE IN INCHES (MILLIMETERS).
- LEAD SPACING TOLERANCE IS NON-CUMULATIVE.
- PACKAGE WARP SHALL NOT EXCEED 0.05MM DATUM -C-
- ALL GROUND LEADS AND GROUND PADDLE MUST BE SOLDERED TO PCB RF GROUND.

Package Information

| Part Number | Package Body Material | Lead Finish | MSL Rating | Package Marking ^[2] |
|-------------|-----------------------|------------------|---------------------|--------------------------------|
| HMC519LC4 | Alumina, White | Gold over Nickel | MSL3 ^[1] | H519 XXXX |

[1] Max peak reflow temperature of 260 °C

[2] 4-Digit lot number XXXX



GaAs PHEMT MMIC LOW NOISE AMPLIFIER, 18 - 31 GHz

Pad Descriptions

| Pad Number | Function | Description | Interface Schematic |
|---------------------------|------------------|---|---------------------|
| 1, 5 - 14, 18, 20, 22, 24 | N/C | Not Connected | |
| 2, 4, 15, 17 | GND | Package bottom has exposed metal paddle that must be connected to RF/DC ground. | |
| 3 | RFIN | This pad is AC coupled and matched to 50 Ohms | |
| 16 | RFOUT | This pad is AC coupled and matched to 50 Ohms | |
| 19, 21, 23 | Vdd3, Vdd2, Vdd1 | Power Supply Voltage for the amplifier. See application circuit for required external components. | |

Application Circuit

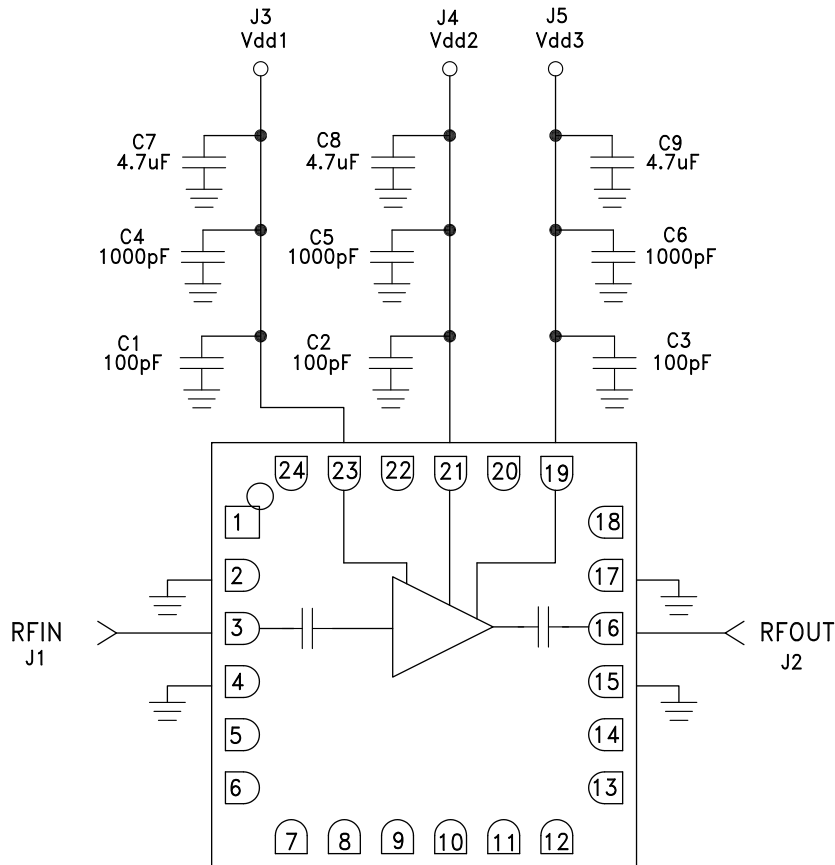

Evaluation PCB

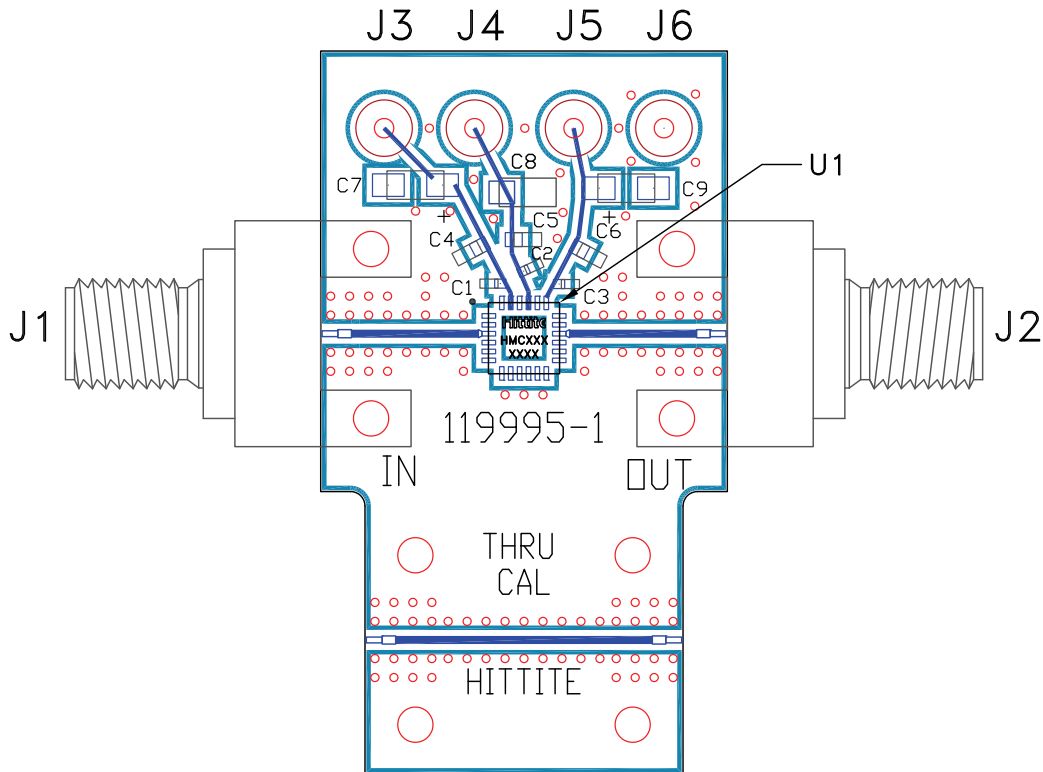

List of Material for Evaluation PCB 119667 [1]

| Item | Description |
|------------|---------------------------------|
| J1, J2 | 2.92mm PCB mount K-Connector |
| J3 - J6 | DC Pin |
| C1, C2, C3 | 100pF Capacitor, 0402 Pkg. |
| C4, C5, C6 | 1000pF Capacitor, 0603 Pkg. |
| C7, C8, C9 | 4.7 μ F Capacitor, Tantalum |
| U1 | HMC519LC4 Amplifier |
| PCB [2] | 11995 Evaluation PCB |

[1] Reference this number when ordering complete evaluation PCB

[2] Circuit Board Material: Rogers 4350.

The circuit board used in this application should use RF circuit design techniques. Signal lines should have 50 Ohm impedance while the package ground leads and exposed paddle should be connected directly to the ground plane similar to that shown. A sufficient number of via holes should be used to connect the top and bottom ground planes. The evaluation board should be mounted to an appropriate heat sink. The evaluation circuit board shown is available from Hittite upon request.



Стандарт Электрон Связь

Мы молодая и активно развивающаяся компания в области поставок электронных компонентов. Мы поставляем электронные компоненты отечественного и импортного производства напрямую от производителей и с крупнейших складов мира.

Благодаря сотрудничеству с мировыми поставщиками мы осуществляем комплексные и плановые поставки широчайшего спектра электронных компонентов.

Собственная эффективная логистика и склад в обеспечивает надежную поставку продукции в точно указанные сроки по всей России.

Мы осуществляем техническую поддержку нашим клиентам и предпродажную проверку качества продукции. На все поставляемые продукты мы предоставляем гарантию .

Осуществляем поставки продукции под контролем ВП МО РФ на предприятия военно-промышленного комплекса России , а также работаем в рамках 275 ФЗ с открытием отдельных счетов в уполномоченном банке. Система менеджмента качества компании соответствует требованиям ГОСТ ISO 9001.

Минимальные сроки поставки, гибкие цены, неограниченный ассортимент и индивидуальный подход к клиентам являются основой для выстраивания долгосрочного и эффективного сотрудничества с предприятиями радиоэлектронной промышленности, предприятиями ВПК и научно-исследовательскими институтами России.

С нами вы становитесь еще успешнее!

Наши контакты:

Телефон: +7 812 627 14 35

Электронная почта: sales@st-electron.ru

Адрес: 198099, Санкт-Петербург,
Промышленная ул, дом № 19, литера Н,
помещение 100-Н Офис 331