

## FEATURES

- Dual 12-bit SAR ADC**
- Simultaneous sampling**
- Throughput rate: 3 MSPS per channel**
- Specified for  $V_{DD}$  at 2.5 V**
- No conversion latency**
- Power dissipation: 26 mW at 3 MSPS**
- On-chip reference:  $2.048\text{ V} \pm 0.25\%$ , 6 ppm/°C**
- Dual conversion with read**
- High speed serial interface: SPI-/QSPI™-/MICROWIRE™-/ DSP-compatible**
- 40°C to +125°C operation**
- Available in a 16-lead TSSOP**

## APPLICATIONS

- Data acquisition systems**
- Motion control**
- I and Q demodulation**

## GENERAL DESCRIPTION

The AD7352<sup>1</sup> is a dual, 12-bit, high speed, low power, successive approximation ADC that operates from a single 2.5 V power supply and features throughput rates up to 3 MSPS. The part contains two ADCs, each preceded by a low noise, wide bandwidth track-and-hold circuit that can handle input frequencies in excess of 110 MHz.

The conversion process and data acquisition use standard control inputs allowing for easy interfacing to microprocessors or DSPs. The input signal is sampled on the falling edge of CS; and a conversion is also initiated at this point. The conversion time is determined by the SCLK frequency.

The AD7352 uses advanced design techniques to achieve very low power dissipation at high throughput rates. With a 2.5 V supply and a 3 MSPS throughput rate, the part consumes 10 mA typically. The part also offers a flexible power/throughput rate management options.

The analog input range for the part is the differential common-mode  $\pm V_{REF}/2$ . The AD7352 has an on-chip 2.048 V reference that can be overdriven when an external reference is preferred.

The AD7352 is available in a 16-lead thin shrink small outline package (TSSOP).

<sup>1</sup> Protected by U.S. Patent No. 6,681,332.

### Rev. B

### Document Feedback

Information furnished by Analog Devices is believed to be accurate and reliable. However, no responsibility is assumed by Analog Devices for its use, nor for any infringements of patents or other rights of third parties that may result from its use. Specifications subject to change without notice. No license is granted by implication or otherwise under any patent or patent rights of Analog Devices. Trademarks and registered trademarks are the property of their respective owners.

## FUNCTIONAL BLOCK DIAGRAM

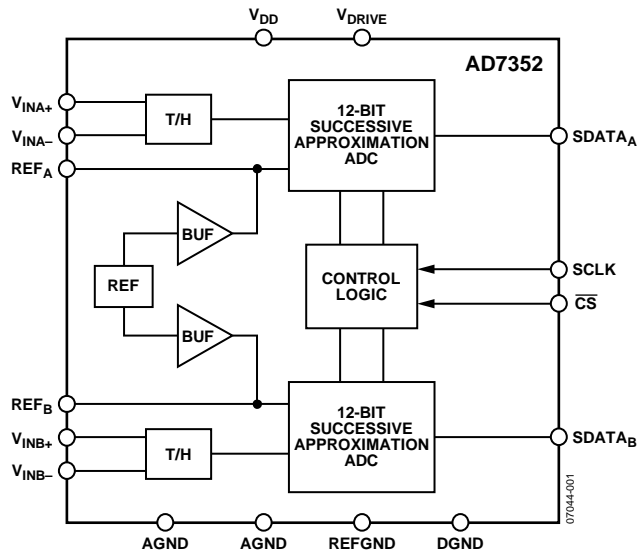

Figure 1.

## PRODUCT HIGHLIGHTS

1. **Two Complete ADC Functions.**  
These functions allow simultaneous sampling and conversion of two channels. The conversion result of both channels is simultaneously available on separate data lines or in succession on one data line if only one serial port is available.
2. **High Throughput With Low Power Consumption.**  
The AD7352 offers a 3 MSPS throughput rate with 26 mW power consumption.
3. **No Conversion Latency.**  
The AD7352 features two standard successive approximation ADCs with accurate control of the sampling instant via a CS input and, once off, conversion control.

Table 1. Related Devices

Generic	Resolution	Throughput	Analog Input
AD7356	12-bit	5 MSPS	Differential
AD7357	14-bit	4.2MSPS	Differential
AD7266	12-bit	2 MSPS	Differential/single-ended
AD7866	12-bit	1 MSPS	Single-ended
AD7366	12-bit	1 MSPS	Single-ended bipolar
AD7367	14-bit	1 MSPS	Single-ended bipolar

## TABLE OF CONTENTS

Features .....	1	Analog Inputs.....	13
Applications.....	1	Driving Differential Inputs .....	13
Functional Block Diagram .....	1	Voltage Reference .....	14
General Description .....	1	ADC Transfer Function.....	14
Product Highlights .....	1	Modes of Operation .....	15
Revision History .....	2	Normal Mode.....	15
Specifications.....	3	Partial Power-Down Mode .....	15
Timing Specifications .....	5	Full Power-Down Mode .....	16
Absolute Maximum Ratings.....	6	Power-Up Times.....	17
ESD Caution.....	6	Power vs. Throughput Rate.....	17
Pin Configuration and Function Descriptions.....	7	Serial Interface .....	18
Typical Performance Characteristics .....	8	Application Hints .....	19
Terminology .....	10	Grounding and Layout .....	19
Theory of Operation .....	12	Evaluating the AD7352 Performance .....	19
Circuit Information.....	12	Outline Dimensions .....	20
Converter Operation.....	12	Ordering Guide .....	20
Analog Input Structure.....	12		

## REVISION HISTORY

### 8/15—Rev. A to Rev. B

Changes to Figure 20.....	14
---------------------------	----

### 8/11—Rev. 0 to Rev. A

Added Applications Section.....	1
Changes to Table 1.....	1
Changes to Figure 21 and Figure 22.....	14
Added Voltage Reference Section.....	14
Updated Outline Dimensions .....	20

### 10/08—Revision 0: Initial Version

## SPECIFICATIONS

$V_{DD} = 2.5 \text{ V} \pm 10\%$ ,  $V_{DRIVE} = 2.25 \text{ V}$  to  $3.6 \text{ V}$ , internal reference =  $2.048 \text{ V}$ ,  $f_{SCLK} = 48 \text{ MHz}$ ,  $f_{SAMPLE} = 3 \text{ MSPS}$ ,  $T_A = T_{MIN}$  to  $T_{MAX}^1$ , unless otherwise noted.

**Table 2.**

Parameter	Min	Typ	Max	Unit	Test Conditions/Comments
<b>DYNAMIC PERFORMANCE</b>					
Signal-to-Noise Ratio (SNR) <sup>2</sup>	70	71.5		dB	$f_{IN} = 1 \text{ MHz}$ sine wave
Signal-to-(Noise and Distortion) (SINAD) <sup>2</sup>	69.5	71		dB	
Total Harmonic Distortion (THD) <sup>2</sup>		-84	-77.5	dB	
Spurious Free Dynamic Range (SFDR) <sup>2</sup>		-85	-78.5	dB	
Intermodulation Distortion (IMD) <sup>2</sup>					$f_a = 1 \text{ MHz} + 50 \text{ kHz}$ , $f_b = 1 \text{ MHz} - 50 \text{ kHz}$
Second-Order Terms		-84		dB	
Third-Order Terms		-76		dB	
ADC-to-ADC Isolation <sup>2</sup>		-100		dB	$f_{IN} = 1 \text{ MHz}$ , $f_{NOISE} = 100 \text{ kHz}$ to $2.5 \text{ MHz}$
CMRR <sup>2</sup>		-100		dB	$f_{NOISE} = 100 \text{ kHz}$ to $2.5 \text{ MHz}$
<b>SAMPLE AND HOLD</b>					
Aperture Delay			3.5	ns	
Aperture Delay Match			40	ps	
Aperture Jitter		16		ps	
Full Power Bandwidth					
@ 3 dB		110		MHz	
@ 0.1 dB		77		MHz	
<b>DC ACCURACY</b>					
Resolution	12			Bits	
Integral Nonlinearity (INL) <sup>2</sup>		$\pm 0.4$	$\pm 1$	LSB	Guaranteed no missed codes to 12 bits
Differential Nonlinearity (DNL) <sup>2</sup>		$\pm 0.5$	$\pm 0.99$	LSB	
Positive Full-Scale Error <sup>2</sup>		$\pm 1$	$\pm 6$	LSB	
Positive Full-Scale Error Match <sup>2</sup>		$\pm 2$	$\pm 8$	LSB	
Midscale Error <sup>2</sup>		+5	0/+11	LSB	
Midscale Error Match <sup>2</sup>		$\pm 2$	$\pm 8$	LSB	
Negative Full-Scale Error <sup>2</sup>		$\pm 1$	$\pm 6$	LSB	
Negative Full-Scale Error Match <sup>2</sup>		$\pm 2$	$\pm 8$	LSB	
<b>ANALOG INPUT</b>					
Fully Differential Input Range ( $V_{IN+}$ and $V_{IN-}$ )			$V_{CM} \pm V_{REF}/2$	V	$V_{CM}$ = common-mode voltage, $V_{IN+}$ and $V_{IN-}$ must remain within GND and $V_{DD}$
Common-Mode Voltage Range	0.5		1.9	V	The voltage around which $V_{IN+}$ and $V_{IN-}$ are centered
DC Leakage Current		$\pm 0.5$	$\pm 5$	$\mu\text{A}$	
Input Capacitance		32		pF	When in track mode
		8		pF	When in hold mode
<b>REFERENCE INPUT/OUTPUT</b>					
$V_{REF}$ Input Voltage Range	$2.048 + 0.1$		$V_{DD}$	V	
$V_{REF}$ Input Current		0.3	0.45	mA	When in reference overdrive mode
$V_{REF}$ Output Voltage	2.038		2.058	V	$2.048 \text{ V} \pm 0.5\% \text{ max}$ @ $V_{DD} = 2.5 \text{ V} \pm 5\%$
	2.043		2.053	V	$2.048 \text{ V} \pm 0.25\% \text{ max}$ @ $V_{DD} = 2.5 \text{ V} \pm 5\%$ and $25^\circ\text{C}$
$V_{REF}$ Temperature Coefficient		6	20	ppm/ $^\circ\text{C}$	
$V_{REF}$ Long Term Stability		100		ppm	For 1000 hours
$V_{REF}$ Thermal Hysteresis <sup>2</sup>		50		ppm	
$V_{REF}$ Noise		60		$\mu\text{V rms}$	
$V_{REF}$ Output Impedance		1		$\Omega$	

Parameter	Min	Typ	Max	Unit	Test Conditions/Comments
<b>LOGIC INPUTS</b>					
Input High Voltage ( $V_{INH}$ )	$0.6 \times V_{DRIVE}$			V	$V_{IN} = 0 \text{ V or } V_{DRIVE}$
Input Low Voltage ( $V_{INL}$ )			$0.3 \times V_{DRIVE}$	V	
Input Current ( $I_{IN}$ )			$\pm 1$	$\mu\text{A}$	
Input Capacitance ( $C_{IN}$ )		3		pF	
<b>LOGIC OUTPUTS</b>					
Output High Voltage ( $V_{OH}$ )	$V_{DRIVE} - 0.2$			V	
Output Low Voltage ( $V_{OL}$ )			0.2	V	
Floating-State Leakage Current			$\pm 1$	$\mu\text{A}$	
Floating-State Output Capacitance		5.5		pF	
Output Coding		Straight binary			
<b>CONVERSION RATE</b>					
Conversion Time	$t_2 + 13 \times t_{SCLK}$			ns	Full-scale step input, settling to 0.5 LSBs
Track-and-Hold Acquisition Time <sup>2</sup>			30	ns	
Throughput Rate			3	MSPS	
<b>POWER REQUIREMENTS<sup>3</sup></b>					
$V_{DD}$	2.25		2.75	V	Nominal $V_{DD} = 2.5 \text{ V}$
$V_{DRIVE}$	2.25		3.6	V	
$I_{TOTAL}$ <sup>4</sup>					Digital inputs = 0 V or $V_{DRIVE}$
Normal Mode (Operational)		10	15	mA	
Normal Mode (Static)		6	7.5	mA	SCLK on or off
Partial Power-Down Mode		3.5	4.5	mA	SCLK on or off
Full Power-Down Mode		5	40	$\mu\text{A}$	SCLK on or off, $-40^\circ\text{C}$ to $+85^\circ\text{C}$
			90	$\mu\text{A}$	SCLK on or off, $85^\circ\text{C}$ to $125^\circ\text{C}$
Power Dissipation					
Normal Mode (Operational)		26	45	mW	
Normal Mode (Static)		16	21	mW	SCLK on or off
Partial Power-Down Mode		9.5	11.5	mW	SCLK on or off
Full Power-Down Mode		16	110	$\mu\text{W}$	SCLK on or off, $-40^\circ\text{C}$ to $+85^\circ\text{C}$
			250	$\mu\text{W}$	SCLK on or off, $85^\circ\text{C}$ to $125^\circ\text{C}$

<sup>1</sup> Temperature ranges are as follows: Y grade:  $-40^\circ\text{C}$  to  $+125^\circ\text{C}$ ; B grade:  $-40^\circ\text{C}$  to  $+85^\circ\text{C}$ .

<sup>2</sup> See the Terminology section.

<sup>3</sup> Current and power typical specifications are based on results with  $V_{DD} = 2.5 \text{ V}$  and  $V_{DRIVE} = 3.0 \text{ V}$ .

<sup>4</sup>  $I_{TOTAL}$  is the total current flowing in  $V_{DD}$  and  $V_{DRIVE}$ .

**TIMING SPECIFICATIONS**

$V_{DD} = 2.5 \text{ V} \pm 10\%$ ,  $V_{DRIVE} = 2.25 \text{ V}$  to  $3.6 \text{ V}$ , internal reference =  $2.048 \text{ V}$ ,  $T_A = T_{MAX}$  to  $T_{MIN}$ <sup>1</sup>, unless otherwise noted.

**Table 3.**

Parameter	Limit at $T_{MIN}$ , $T_{MAX}$	Unit	Description
$f_{SCLK}$	50	kHz min	
	48	MHz max	
$t_{CONVERT}$	$t_2 + 13 \times t_{SCLK}$	ns max	$t_{SCLK} = 1/f_{SCLK}$
$t_{QUIET}$	5	ns min	Minimum time between end of serial read and next falling edge of $\overline{CS}$
$t_2$	5	ns min	$\overline{CS}$ to SCLK setup time
$t_3^2$	6	ns max	Delay from $\overline{CS}$ until $SDATA_A$ and $SDATA_B$ are three-state disabled
$t_4^{2,3}$			Data access time after SCLK falling edge
	12.5	ns max	$1.8 \text{ V} \leq V_{DRIVE} < 2.25 \text{ V}$
	11	ns max	$2.25 \text{ V} \leq V_{DRIVE} < 2.75 \text{ V}$
	9.5	ns max	$2.75 \text{ V} \leq V_{DRIVE} < 3.3 \text{ V}$
	9	ns max	$3.3 \text{ V} \leq V_{DRIVE} \leq 3.6 \text{ V}$
$t_5$	5	ns min	SCLK low pulse width
$t_6$	5	ns min	SCLK high pulse width
$t_7^2$	3.5	ns min	SCLK to data valid hold time
$t_8^2$	9.5	ns max	$\overline{CS}$ rising edge to $SDATA_A$ , $SDATA_B$ high impedance
$t_9$	5	ns min	$\overline{CS}$ rising edge to falling edge pulse width
$t_{10}^2$	4.5	ns min	SCLK falling edge to $SDATA_A$ , $SDATA_B$ high impedance
	9.5	ns max	SCLK falling edge to $SDATA_A$ , $SDATA_B$ high impedance

<sup>1</sup> Temperature ranges are as follows: Y grade:  $-40^\circ\text{C}$  to  $+125^\circ\text{C}$ ; B grade:  $-40^\circ\text{C}$  to  $+85^\circ\text{C}$ .

<sup>2</sup> Specified with a load capacitance of  $10 \text{ pF}$  on  $SDATA_A$  and  $SDATA_B$ .

<sup>3</sup> The time required for the output to cross  $0.4 \text{ V}$  or  $2.4 \text{ V}$ .

## ABSOLUTE MAXIMUM RATINGS

Table 4.

Parameter	Rating
$V_{DD}$ to AGND, DGND, REFGND	-0.3 V to +3 V
$V_{DRIVE}$ to AGND, DGND, REFGND	-0.3 V to +5 V
$V_{DD}$ to $V_{DRIVE}$	-5 V to +3 V
AGND to DGND to REFGND	-0.3 V to +0.3 V
Analog Input Voltages <sup>1</sup> to AGND	-0.3 V to $V_{DD} + 0.3$ V
Digital Input Voltages <sup>2</sup> to DGND	-0.3 V to $V_{DRIVE} + 0.3$ V
Digital Output Voltages <sup>3</sup> to DGND	-0.3 V to $V_{DRIVE} + 0.3$ V
Input Current to Any Pin Except Supply Pins <sup>4</sup>	±10 mA
Operating Temperature Range	
Y Grade	-40°C to +125°C
B Grade	-40°C to +85°C
Storage Temperature Range	-65°C to +150°C
Junction Temperature	150°C
TSSOP	
$\theta_{JA}$ Thermal Impedance	143°C/W
$\theta_{JC}$ Thermal Impedance	45°C/W
Lead Temperature, Soldering	
Reflow Temperature (10 sec to 30 sec)	255°C
ESD	1.5 kV

<sup>1</sup> Analog input voltages are  $V_{INA+}$ ,  $V_{INA-}$ ,  $V_{INB+}$ ,  $V_{INB-}$ ,  $REF_{AV}$  and  $REF_B$ .

<sup>2</sup> Digital input voltages are  $\overline{CS}$  and SCLK.

<sup>3</sup> Digital output voltages are  $SDATA_A$  and  $SDATA_B$ .

<sup>4</sup> Transient currents of up to 100 mA do not cause SCR latch-up.

Stresses at or above those listed under Absolute Maximum Ratings may cause permanent damage to the product. This is a stress rating only; functional operation of the product at these or any other conditions above those indicated in the operational section of this specification is not implied. Operation beyond the maximum operating conditions for extended periods may affect product reliability.

### ESD CAUTION



**ESD (electrostatic discharge) sensitive device.** Charged devices and circuit boards can discharge without detection. Although this product features patented or proprietary protection circuitry, damage may occur on devices subjected to high energy ESD. Therefore, proper ESD precautions should be taken to avoid performance degradation or loss of functionality.

## PIN CONFIGURATION AND FUNCTION DESCRIPTIONS

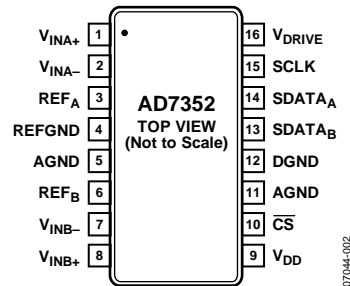

Figure 2. Pin Configuration

Table 5. Pin Function Descriptions

Pin No.	Mnemonic	Description
1, 2	$V_{INA+}$ , $V_{INA-}$	Analog Inputs of ADC A. These analog inputs form a fully differential pair.
3, 6	$REF_A$ , $REF_B$	Reference Decoupling Capacitor Pins. Decoupling capacitors are connected between these pins and the REFGND pin to decouple the reference buffer for each respective ADC. It is recommended to decouple each reference pin with a 10 $\mu$ F capacitor. Provided the output is buffered, the on-chip reference can be taken from these pins and applied externally to the rest of the system. The nominal internal reference voltage is 2.048 V and appears at these pins. These pins can also be overdriven by an external reference. The input voltage range for the external reference is 2.048 V + 100 mV to $V_{DD}$ .
4	REFGND	Reference Ground. This is the ground reference point for the reference circuitry on the AD7352. Any external reference signal should be referred to this REFGND voltage. Decoupling capacitors must be placed between this pin and the $REF_A$ and $REF_B$ pins. Connect the REFGND pin to the AGND plane of a system.
5, 11	AGND	Analog Ground. This is the ground reference point for all analog circuitry on the AD7352. Refer all analog input signals to this AGND voltage. The AGND and DGND voltages should ideally be at the same potential and must not be more than 0.3 V apart, even on a transient basis.
7, 8	$V_{INB-}$ , $V_{INB+}$	Analog Inputs of ADC B. These analog inputs form a fully differential pair.
9	$V_{DD}$	Power Supply Input. The $V_{DD}$ range for the AD7352 is 2.5 V $\pm$ 10%. Decouple the supply to AGND with a 0.1 $\mu$ F capacitor in parallel with a 10 $\mu$ F tantalum capacitor.
10	$\overline{CS}$	Chip Select. Active low, logic input. This input provides the dual functions of initiating conversions on the AD7352 and framing the serial data transfer.
12	DGND	Digital Ground. This is the ground reference point for all digital circuitry on the AD7352. Connect this pin to the DGND plane of a system. The DGND and AGND voltages should ideally be at the same potential and must not be more than 0.3 V apart, even on a transient basis.
13, 14	$SDATA_B$ , $SDATA_A$	Serial Data Outputs. The data output is supplied to each pin as a serial data stream. The bits are clocked out on the falling edge of the SCLK input. To access the 12 bits of data from the AD7352, 14 SCLK falling edges are required. The data simultaneously appears on both data output pins from the simultaneous conversions of both ADCs. The data stream consists of two leading zeros followed by 12 bits of conversion data. The data is provided MSB first. If $\overline{CS}$ is held low for 16 SCLK cycles rather than 14 on the AD7352, then two trailing zeros appear after the 12 bits of data. If $\overline{CS}$ is held low for a further 16 SCLK cycles on either $SDATA_A$ or $SDATA_B$ , the data from the other ADC follows on the $SDATA$ pins. This allows data from a simultaneous conversion on both ADCs to be gathered in serial format on either $SDATA_A$ or $SDATA_B$ .
15	SCLK	Serial Clock, Logic Input. A serial clock input provides the serial clock for accessing the data from the AD7352. This clock is also used as the clock source for the conversion process.
16	$V_{DRIVE}$	Logic Power Supply Input. The voltage supplied at this pin determines at what voltage the interface operates. The voltage at this pin may be different than the voltage at $V_{DD}$ . The $V_{DRIVE}$ supply should be decoupled to DGND with a 0.1 $\mu$ F capacitor in parallel with a 10 $\mu$ F tantalum capacitor.

TYPICAL PERFORMANCE CHARACTERISTICS

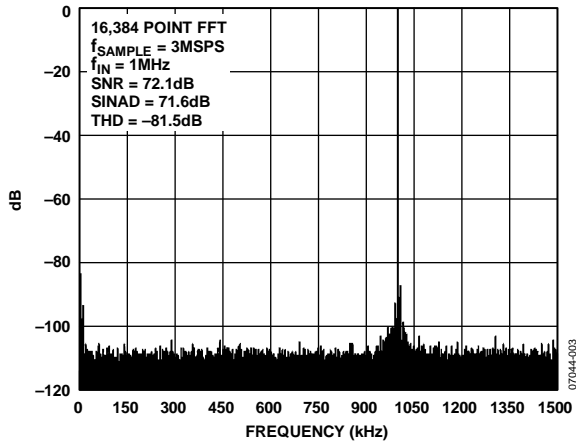

Figure 3. Typical FFT

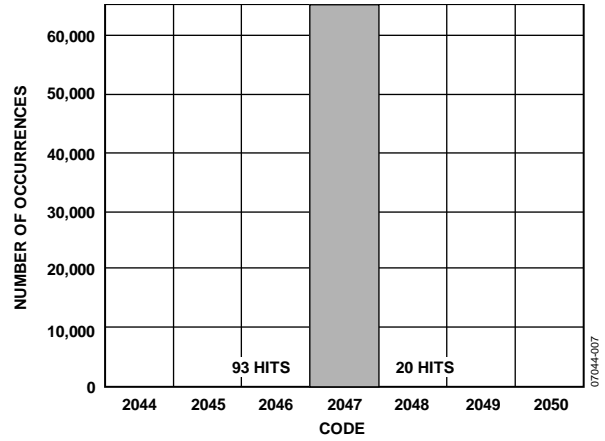

Figure 6. Histogram of Codes for 65,000 Samples

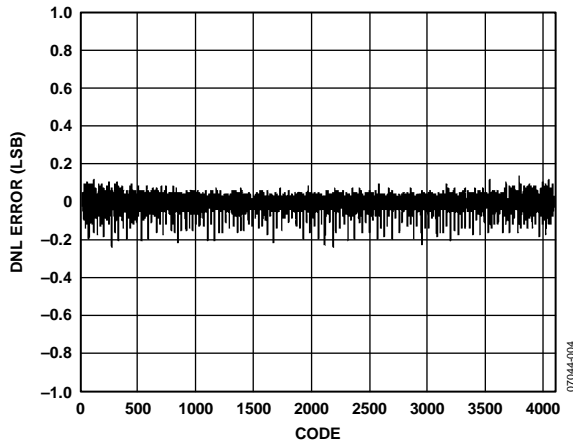

Figure 4. Typical DNL Error



Figure 7. SNR vs. Analog Input Frequency



Figure 5. Typical INL Error

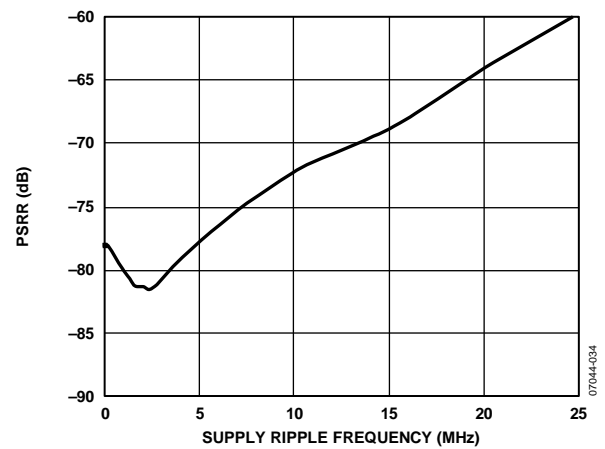

Figure 8. PSRR vs. Supply Ripple Frequency with No Supply Decoupling



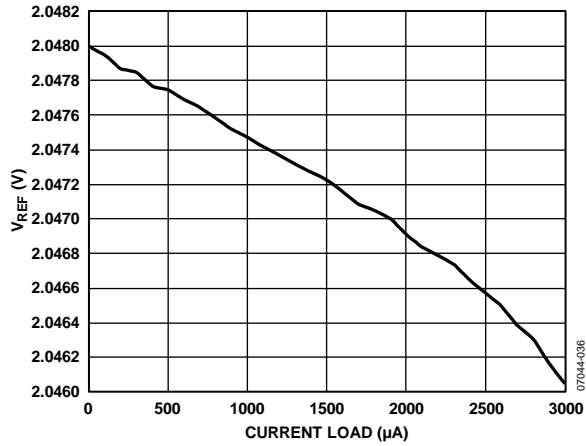

Figure 9.  $V_{REF}$  vs. Reference Output Current Drive



Figure 12. Access Time vs.  $V_{DRIVE}$

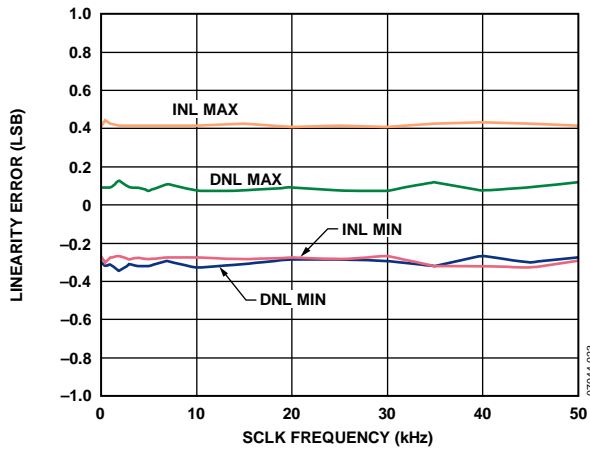

Figure 10. Linearity Error vs. SCLK Frequency



Figure 13. Hold Time vs.  $V_{DRIVE}$



Figure 11. Linearity Error vs. External  $V_{REF}$

## TERMINOLOGY

### Integral Nonlinearity (INL)

INL is the maximum deviation from a straight line passing through the endpoints of the ADC transfer function. The endpoints of the transfer function are zero scale (1 LSB below the first code transition) and full scale (1 LSB above the last code transition).

### Differential Nonlinearity (DNL)

DNL is the difference between the measured and the ideal 1 LSB change between any two adjacent codes in the ADC.

### Negative Full-Scale Error

Negative full-scale error is the deviation of the first code transition (00 ... 000) to (00 ... 001) from the ideal (that is,  $-V_{REF} + 0.5$  LSB) after the midscale error has been adjusted out.

### Negative Full-Scale Error Match

Negative full-scale error match is the difference in negative full-scale error between the two ADCs.

### Midscale Error

Midscale error is the deviation of the midscale code transition (011 ... 111) to (100 ... 000) from the ideal (that is, 0 V).

### Midscale Error Match

Midscale error match is the difference in midscale error between the two ADCs.

### Positive Full-Scale Error

Positive full-scale error is the deviation of the last code transition (111 ... 110) to (111 ... 111) from the ideal (that is,  $V_{REF} - 1.5$  LSB) after the midscale error has been adjusted out.

### Positive Full-Scale Error Match

Positive full-scale error match is the difference in positive full-scale error between the two ADCs.

### ADC-to-ADC Isolation

ADC-to-ADC isolation is a measure of the level of crosstalk between ADC A and ADC B. It is measured by applying a full-scale 1 MHz sine wave signal to one of the two ADCs and applying a full-scale signal of variable frequency to the other ADC. The ADC-to-ADC isolation is defined as the ratio of the power of the 1 MHz signal on the converted ADC to the power of the noise signal on the other ADC that appears in the FFT. The noise frequency on the unselected channel varies from 100 kHz to 2.5 MHz.

### Power Supply Rejection Ratio (PSRR)

PSRR is defined as the ratio of the power in the ADC output at full-scale frequency,  $f$ , to the power of a 100 mV p-p sine wave applied to the ADC  $V_{DD}$  supply of frequency,  $f_s$ . The frequency of the input varies from 5 kHz to 25 MHz.

$$PSRR \text{ (dB)} = 10 \log(P_f/P_{f_s})$$

where:

$P_f$  is the power at frequency,  $f$ , in the ADC output.

$P_{f_s}$  is the power at frequency,  $f_s$ , in the ADC output.

### Common-Mode Rejection Ratio (CMRR)

CMRR is defined as the ratio of the power in the ADC output at full-scale frequency,  $f$ , to the power of a 100 mV p-p sine wave applied to the common-mode voltage of  $V_{IN+}$  and  $V_{IN-}$  of frequency,  $f_s$ .

$$CMRR \text{ (dB)} = 10 \log(P_f/P_{f_s})$$

where:

$P_f$  is the power at frequency,  $f$ , in the ADC output.

$P_{f_s}$  is the power at frequency,  $f_s$ , in the ADC output.

### Track-and-Hold Acquisition Time

The track-and-hold amplifier returns to track mode at the end of a conversion. The track-and-hold acquisition time is the time required for the output of the track-and-hold amplifier to reach its final value, within  $\pm 0.5$  LSB, after the end of a conversion.

### Signal-to-(Noise and Distortion) Ratio (SINAD)

SINAD is the measured ratio of signal-to-(noise and distortion) at the output of the ADC. The signal is the rms amplitude of the fundamental. Noise is the sum of all nonfundamental signals up to half the sampling frequency ( $f_s/2$ ), excluding dc. The ratio is dependent on the number of quantization levels in the digitization process; the more levels, the smaller the quantization noise.

The theoretical SINAD for an ideal N-bit converter with a sine wave input is given by

$$SINAD = (6.02 N + 1.76) \text{ dB}$$

Thus, for a 12-bit converter, SINAD is 74 dB and for a 14-bit converter, SINAD is 86 dB.

### Total Harmonic Distortion (THD)

THD is the ratio of the rms sum of harmonics to the fundamental. For the AD7352, it is defined as

$$THD \text{ (dB)} = -20 \log \frac{\sqrt{V_2^2 + V_3^2 + V_4^2 + V_5^2 + V_6^2}}{V_1}$$

where:

$V_1$  is the rms amplitude of the fundamental.

$V_2$ ,  $V_3$ ,  $V_4$ ,  $V_5$ , and  $V_6$  are the rms amplitudes of the second through the sixth harmonics.

### Spurious Free Dynamic Range (SFDR)

SFDR is the ratio of the rms value of the next largest component in the ADC output spectrum (up to  $f_s/2$  and excluding dc) to the rms value of the fundamental. Normally, the value of this specification is determined by the largest harmonic in the spectrum, but for ADCs where the harmonics are buried in the noise floor, it is a noise peak.

**Intermodulation Distortion (IMD)**

With inputs consisting of sine waves at two frequencies,  $f_a$  and  $f_b$ , any active device with nonlinearities creates distortion products at sum and difference frequencies of  $m f_a \pm n f_b$  where  $m, n = 0, 1, 2, 3$ , and so on. Intermodulation distortion terms are those for which neither  $m$  nor  $n$  is equal to zero. For example, the second-order terms include  $(f_a + f_b)$  and  $(f_a - f_b)$ , while the third-order terms include  $(2f_a + f_b)$ ,  $(2f_a - f_b)$ ,  $(f_a + 2f_b)$ , and  $(f_a - 2f_b)$ .

The AD7352 is tested using the CCIF standard where two input frequencies near the top end of the input bandwidth are used. In this case, the second-order terms are usually distanced in frequency from the original sine waves and the third-order terms are usually at a frequency close to the input frequencies. As a result, the second- and third-order terms are specified separately. The calculation of the intermodulation distortion is as per the THD specification, where it is the ratio of the rms sum of the individual distortion products to the rms amplitude of the sum of the fundamentals expressed in decibels.

**Thermal Hysteresis**

Thermal hysteresis is defined as the absolute maximum change of reference output voltage after the device is cycled through temperature from either

$$T_{HYS+} = +25^{\circ}\text{C to } T_{MAX} \text{ to } +25^{\circ}\text{C}$$

$$T_{HYS-} = +25^{\circ}\text{C to } T_{MIN} \text{ to } +25^{\circ}\text{C}$$

Thermal hysteresis is expressed in ppm using the following equation:

$$V_{HYS} \text{ (ppm)} = \left| \frac{V_{REF}(25^{\circ}\text{C}) - V_{REF}(T_{HYS})}{V_{REF}(25^{\circ}\text{C})} \right| \times 10^6$$

where:

$V_{REF}(25^{\circ}\text{C})$  is  $V_{REF}$  at  $25^{\circ}\text{C}$ .

$V_{REF}(T_{HYS})$  is the maximum change of  $V_{REF}$  at  $T_{HYS+}$  or  $T_{HYS-}$ .

## THEORY OF OPERATION

### CIRCUIT INFORMATION

The AD7352 is a high speed, dual, 12-bit, single-supply, successive approximation analog-to-digital converter (ADC). The part operates from a 2.5 V power supply and features throughput rates of up to 3 MSPS.

The AD7352 contains two on-chip differential track-and-hold amplifiers, two successive approximation ADCs, and a serial interface with two separate data output pins. The part is housed in a 16-lead TSSOP, offering the user considerable space-saving advantages over alternative solutions.

The serial clock input accesses data from the part but also provides the clock source for each successive approximation ADC. The AD7352 has an on-chip 2.048 V reference. If an external reference is desired, the internal reference can be overdriven with a reference value ranging from  $(2.048 \text{ V} + 100 \text{ mV})$  to  $V_{DD}$ . If the internal reference is to be used elsewhere in the system, then the reference output needs to be buffered first. The differential analog input range for the AD7352 is  $V_{CM} \pm V_{REF}/2$ .

The AD7352 features power-down options to allow power saving between conversions. The power-down feature is implemented via the standard serial interface, as described in the Modes of Operation section.

### CONVERTER OPERATION

The AD7352 has two successive approximation ADCs, each based around two capacitive DACs. Figure 14 and Figure 15 show simplified schematics of one of these ADCs in acquisition phase and conversion phase. The ADC comprises a control logic, a SAR, and two capacitive DACs. In Figure 14 (the acquisition phase), SW3 is closed, SW1 and SW2 are in Position A, the comparator is held in a balanced condition, and the sampling capacitor arrays acquire the differential signal on the input.



Figure 14. ADC Acquisition Phase

When the ADC starts a conversion (see Figure 15), SW3 opens while SW1 and SW2 move to Position B, causing the comparator to become unbalanced. Both inputs are disconnected once the conversion begins. The control logic and charge redistribution DACs are used to add and subtract fixed amounts of charge from the sampling capacitor arrays to bring the comparator back into a balanced condition. When the comparator is rebalanced, the conversion is complete. The control logic generates the ADC output code. The output impedances of the sources driving the  $V_{IN+}$  and  $V_{IN-}$  pins must be matched; otherwise, the two inputs may have different settling times, resulting in errors.



Figure 15. ADC Conversion Phase

### ANALOG INPUT STRUCTURE

Figure 16 shows the equivalent circuit of the analog input structure of the AD7352. The four diodes provide ESD protection for the analog inputs. Care must be taken to ensure that the analog input signals never exceed the supply rails by more than 300 mV. This causes these diodes to become forward biased and start conducting into the substrate. These diodes can conduct up to 10 mA without causing irreversible damage to the part.

The C1 capacitors in Figure 16 are typically 8 pF and can primarily be attributed to pin capacitance. The R1 resistors are lumped components made up of the on resistance of the switches. The value of these resistors is typically about 30  $\Omega$ . The C2 capacitors are the sampling capacitors of the ADCs with a capacitance of 32 pF typically.

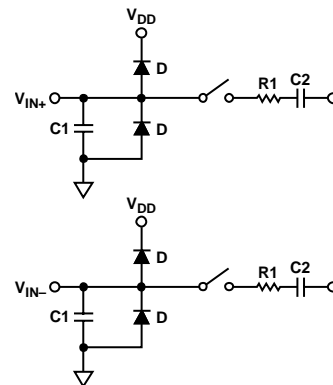

Figure 16. Equivalent Analog Input Circuit, Conversion Phase—Switches Open, Track Phase—Switches Closed

For ac applications, removing high frequency components from the analog input signal is recommended by the use of an RC low-pass filter on the analog input pins. In applications where harmonic distortion and signal-to-noise ratio are critical, the analog input should be driven from a low impedance source. Large source impedances significantly affect the ac performance of the ADC and may necessitate the use of an input buffer amplifier. The choice of the op amp is a function of the particular application.

When no amplifier is used to drive the analog input, limit the source impedance to low values. The maximum source impedance depends on the amount of THD that can be tolerated. THD increases as the source impedance increases and performance degrades. Figure 17 shows a graph of THD vs. the analog input signal frequency for different source impedances.

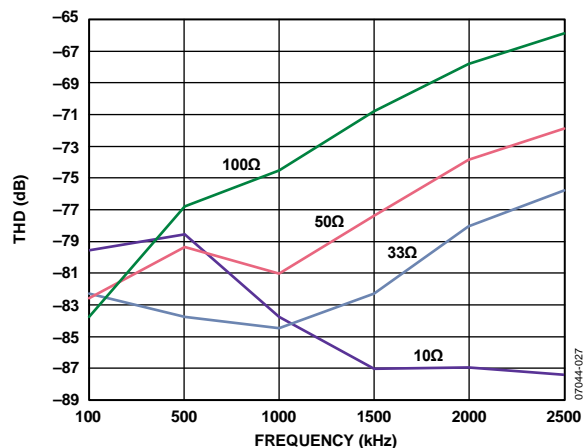

Figure 17. THD vs. Analog Input Signal Frequency for Various Source Impedances

Figure 18 shows a graph of the THD vs. the analog input frequency while sampling at 3 MSPS. In this case, the source impedance is 33 Ω.

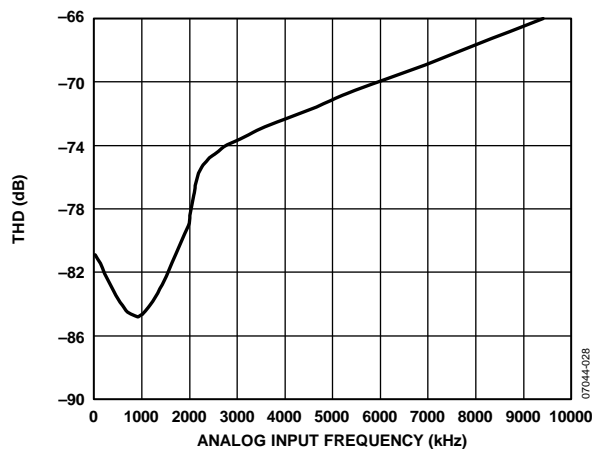

Figure 18. THD vs. Analog Input Frequency

## ANALOG INPUTS

Differential signals have some benefits over single-ended signals, including noise immunity based on the devices common-mode rejection and improvements in distortion performance. Figure 19 defines the fully differential input of the AD7352.

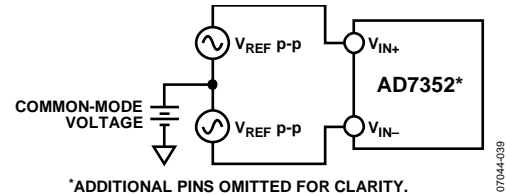

Figure 19. Differential Input Definition

The amplitude of the differential signal is the difference between the signals applied to the  $V_{IN+}$  and  $V_{IN-}$  pins in each differential pair ( $V_{IN+} - V_{IN-}$ ).  $V_{IN+}$  and  $V_{IN-}$  should be simultaneously driven by two signals each of amplitude ( $V_{REF}$ ) that are  $180^\circ$  out of phase. This amplitude of the differential signal is, therefore  $-V_{REF}$  to  $+V_{REF}$  peak-to-peak regardless of the common mode (CM).

CM is the average of the two signals and is, therefore, the voltage on which the two inputs are centered.

$$CM = (V_{IN+} + V_{IN-})/2$$

This results in the span of each input being  $CM \pm V_{REF}/2$ . This voltage has to be set up externally. When setting up the CM, ensure that  $V_{IN+}$  and  $V_{IN-}$  remain within  $GND/V_{DD}$ . When a conversion takes place, CM is rejected, resulting in a virtually noise-free signal of amplitude,  $-V_{REF}$  to  $+V_{REF}$ , corresponding to the digital codes of 0 to 4095 for the AD7352.

## DRIVING DIFFERENTIAL INPUTS

Differential operation requires  $V_{IN+}$  and  $V_{IN-}$  to be driven simultaneously with two equal signals that are  $180^\circ$  out of phase. Because not all applications have a signal preconditioned for differential operation, there is often a need to perform a single-ended-to-differential conversion.

### Differential Amplifier

An ideal method of applying differential drive to the AD7352 is to use a differential amplifier such as the AD8138. This part can be used as a single-ended-to-differential amplifier or as a differential-to-differential amplifier. The AD8138 also provides common-mode level shifting. Figure 20 shows how the AD8138 can be used as a single-ended-to-differential amplifier. The positive and negative outputs of the AD8138 are connected to the respective inputs on the ADC via a pair of series resistors to minimize the effects of switched capacitance on the front end of the ADC. The architecture of the AD8138 results in outputs that are very highly balanced over a wide frequency range without requiring tightly matched external components.

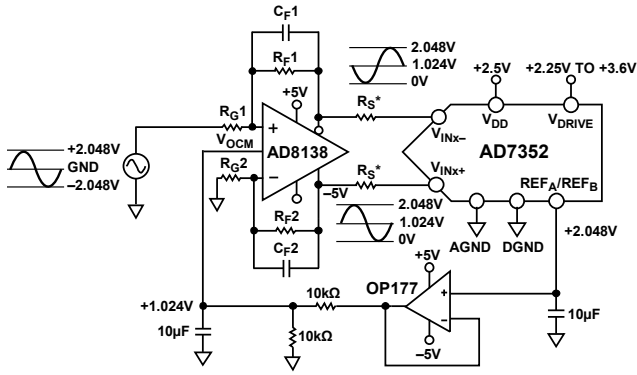

\*MOUNT AS CLOSE TO THE AD7352 AS POSSIBLE.  
 $R_S = 33\Omega$ ;  $R_{G1} = R_{G2} = R_{F1} = R_{F2} = 499\Omega$   
 $C_{F1} = C_{F2} = 39pF$

07044-030

Figure 20. Using the AD8138 as a Single-Ended-to-Differential Amplifier

If the analog inputs source being used has zero impedance, all four resistors ( $R_{G1}$ ,  $R_{G2}$ ,  $R_{F1}$ , and  $R_{F2}$ ) should be the same value as each other. If the source has a  $50\Omega$  impedance and a  $50\Omega$  termination, for example, increase the value of  $R_{G2}$  by  $25\Omega$  to balance this parallel impedance on the input and thus ensure that both the positive and negative analog inputs have the same gain. The outputs of the amplifier are perfectly matched, balanced differential outputs of identical amplitude, and are exactly  $180^\circ$  out of phase.

**Op Amp Pair**

An op amp pair can be used to directly couple a differential signal to one of the analog input pairs of the AD7352. The circuit configurations in Figure 21 and Figure 22 show how an op amp pair can be used to convert a single-ended signal into a differential signal for both a bipolar and unipolar input signal, respectively.

The voltage applied to Point A sets up the common-mode voltage. In both diagrams, it is connected in some way to the reference. The AD8022 is a suitable dual op amp that could be used in this configuration to provide differential drive to the AD7352.

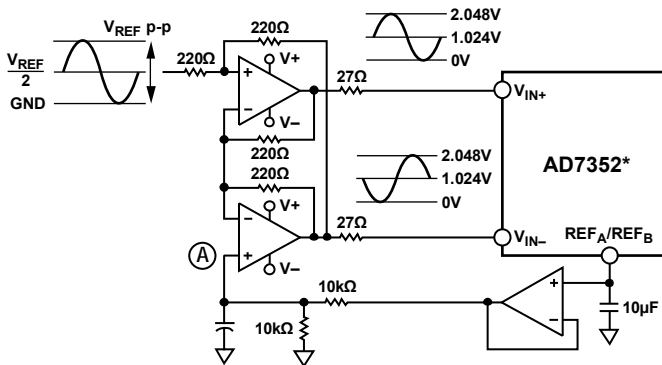

\*ADDITIONAL PINS OMITTED FOR CLARITY.

07044-031

Figure 21. Dual Op Amp Circuit to Convert a Single-Ended Unipolar Signal into a Differential Signal

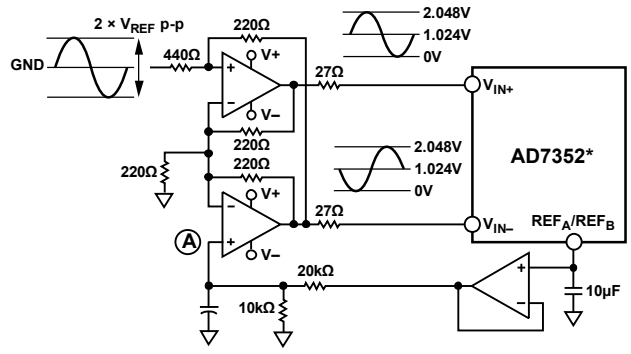

\*ADDITIONAL PINS OMITTED FOR CLARITY.

07044-032

Figure 22. Dual Op Amp Circuit to Convert a Single-Ended Bipolar Signal into a Differential Unipolar Signal

**VOLTAGE REFERENCE**

The AD7352 allows the choice of a very low temperature drift internal voltage reference or an external reference. The internal 2.048 V reference of the AD7352 provides excellent performance and can be used in almost all applications. When the internal reference is used, the reference voltage is present on the  $REF_A$  and  $REF_B$  pins. These pins should be decoupled to  $REF_{GND}$  with  $10\mu F$  capacitors. The internal reference voltage can be used elsewhere in the system, provided it is buffered externally.

The  $REF_A$  and  $REF_B$  pins can also be overdriven with an external voltage reference if desired. The applied reference voltage can range from  $2.048V + 100mV$  to  $V_{DD}$ . A common choice would be to use an external 2.5 V reference such as the ADR441 or ADR431.

**ADC TRANSFER FUNCTION**

The output coding for the AD7352 is straight binary. The designed code transitions occur at successive LSB values (1 LSB, 2 LSBs, and so on). The LSB size is  $(2 \times V_{REF})/4096$ . The ideal transfer characteristic is shown in Figure 23.

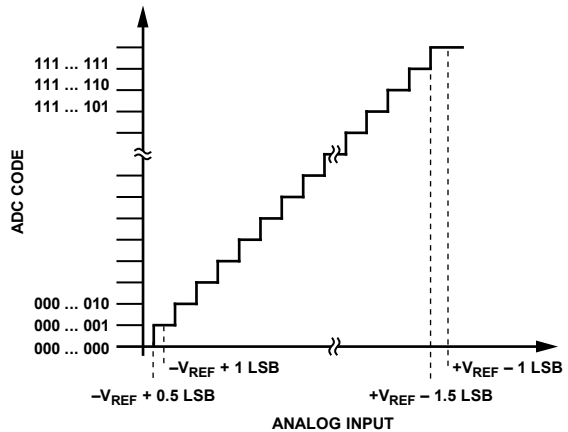

Figure 23. AD7352 Ideal Transfer Characteristic

07044-014



## MODES OF OPERATION

The mode of operation of the AD7352 is selected by controlling the logic state of the  $\overline{CS}$  signal during a conversion. There are three possible modes of operation: normal mode, partial power-down mode, and full power-down mode. After a conversion is initiated, the point at which  $\overline{CS}$  is pulled high determines which power-down mode, if any, the device enters. Similarly, if already in power-down mode,  $\overline{CS}$  can control whether the device returns to normal operation or remains in power-down mode.

These modes of operation are designed to provide flexible power management options. These options can be chosen to optimize the power dissipation/throughput rate ratio for the differing application requirements.

### NORMAL MODE

Normal mode is intended for applications needing the fastest throughput rates because the user does not have to worry about any power-up times because the AD7352 remains fully powered at all times. Figure 24 shows the general diagram of the operation of the AD7352 in normal mode.

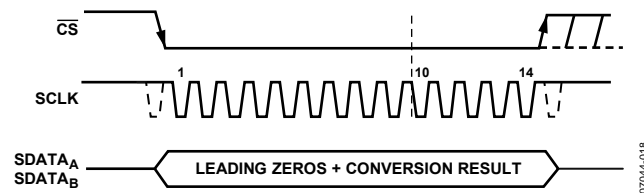

Figure 24. Normal Mode Operation

The conversion is initiated on the falling edge of  $\overline{CS}$ , as described in the Serial Interface section. To ensure that the part remains fully powered up at all times,  $\overline{CS}$  must remain low until at least 10 SCLK falling edges have elapsed after the falling edge of  $\overline{CS}$ . If  $\overline{CS}$  is brought high any time after the 10<sup>th</sup> SCLK falling edge, but before the 14<sup>th</sup> SCLK falling edge, the part remains powered up; however, the conversion is terminated and  $SDATA_A$  and  $SDATA_B$  go back into three-state. To complete the conversion and access the conversion result for the AD7352, 14 serial clock cycles are required. The  $SDATA$  lines do not return to three-state after 14 SCLK cycles have elapsed but instead do so when  $\overline{CS}$  is brought high again. If  $\overline{CS}$  is left low for another two SCLK cycles, two trailing zeros are clocked out after the data. If  $\overline{CS}$  is left low for a further 14 SCLK cycles, the result for the other ADC on board is also accessed on the same  $SDATA$  line (see Figure 31 and the Serial Interface section).

Once 32 SCLK cycles have elapsed, the  $SDATA$  line returns to three-state on the 32<sup>nd</sup> SCLK falling edge. If  $\overline{CS}$  is brought high prior to this, the  $SDATA$  line returns to three-state at that point. Thus,  $\overline{CS}$  may idle low after 32 SCLK cycles until it is brought high again sometime prior to the next conversion. The bus still returns to three-state upon completion of the dual result read.

When a data transfer is complete and  $SDATA_A$  and  $SDATA_B$  have returned to three-state, another conversion can be initiated after the quiet time,  $t_{QUIET}$ , has elapsed by bringing  $\overline{CS}$  low again (assuming the required acquisition time has been allowed).

### PARTIAL POWER-DOWN MODE

Partial power-down mode is intended for use in applications in which slower throughput rates are required. Either the ADC is powered down between each conversion or a series of conversions can be performed at a high throughput rate, and the ADC is then powered between these bursts of several conversions. It is recommended that the AD7352 not remain in partial power-down mode for longer than 100  $\mu$ s. When the AD7352 is in partial power-down, all analog circuitry is powered down except for the on-chip reference and reference buffers.

To enter partial power-down mode, the conversion process must be interrupted by bringing  $\overline{CS}$  high any time after the second falling edge of SCLK and before the 10<sup>th</sup> falling edge of SCLK, as shown in Figure 25. When  $\overline{CS}$  has been brought high in this window of SCLKs, the part enters partial power-down, the conversion that was initiated by the falling edge of  $\overline{CS}$  is terminated, and  $SDATA_A$  and  $SDATA_B$  go back into three-state. If  $\overline{CS}$  is brought high before the second SCLK falling edge, the part remains in normal mode and does not power down. This avoids accidental power-down due to glitches on the  $\overline{CS}$  line.

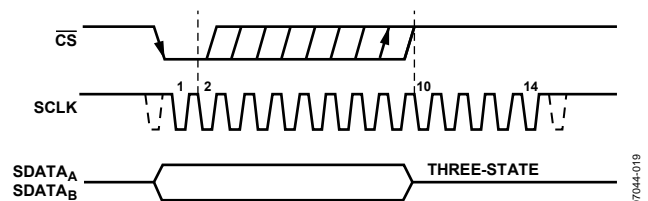

Figure 25. Entering Partial Power-Down Mode

To exit this mode of operation and power up the AD7352 again, perform a dummy conversion. The device begins to power up on the falling edge of  $\overline{CS}$  and continues to power up as long as  $\overline{CS}$  is held low until after the falling edge of the 10<sup>th</sup> SCLK. The device is fully powered up after approximately 333 ns have elapsed (or one full conversion), and valid data results from the next conversion, as shown in Figure 26. If  $\overline{CS}$  is brought high before the second falling edge of SCLK, the AD7352 again goes into partial power-down. This avoids accidental power-up due to glitches on the  $\overline{CS}$  line. Although the device may begin to power up on the falling edge of  $\overline{CS}$ , it powers down again on the rising edge of  $\overline{CS}$ . If the AD7352 is already in partial power-down mode and  $\overline{CS}$  is brought high between the second and 10<sup>th</sup> falling edges of SCLK, the device enters full power-down mode.

**FULL POWER-DOWN MODE**

Full power-down mode is intended for use in applications where throughput rates slower than those in partial power-down mode are required because power-up from a full power-down takes substantially longer than that from a partial power-down. This mode is more suited to applications in which a series of conversions performed at a relatively high throughput rate are followed by a long period of inactivity and, thus, power-down. When the AD7352 is in full power-down mode, all analog circuitry is powered down including the on-chip reference and reference buffers. Full power-down mode is entered in a similar way as partial power-down mode, except that the timing sequence shown in Figure 25 must be executed twice. The conversion process must be interrupted in a similar fashion by bringing  $\overline{CS}$  high anywhere after the second falling edge of SCLK and before the 10<sup>th</sup> falling edge of SCLK. The device enters partial power-down mode at this point.

To reach full power-down mode, the next conversion cycle must be interrupted in the same way, as shown in Figure 27. When  $\overline{CS}$  is brought high in this window of SCLKs, the part fully powers down. Note that it is not necessary to complete the 14 or 16 SCLKs once  $\overline{CS}$  has been brought high to enter a power-down mode.

To exit full power-down mode and power-up the AD7352, perform a dummy conversion, similar to powering up from partial power-down. On the falling edge of  $\overline{CS}$ , the device begins to power up as long as  $\overline{CS}$  is held low until after the falling edge of the 10<sup>th</sup> SCLK. The required power-up time must elapse before a conversion can be initiated, as shown in Figure 28.

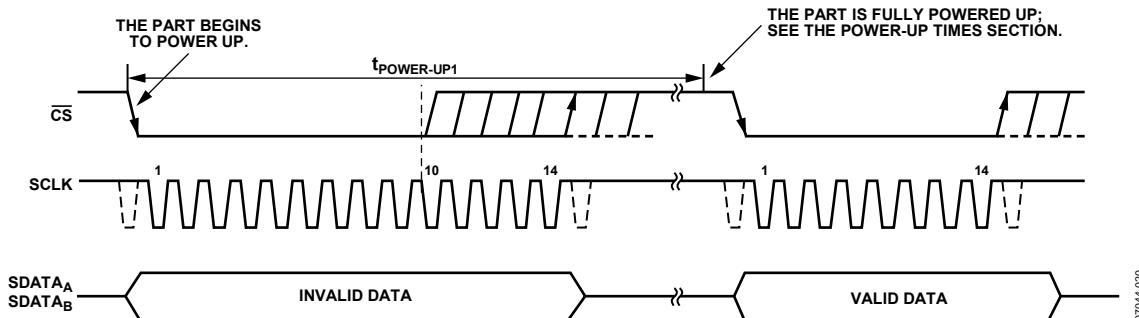

Figure 26. Exiting Partial Power-Down Mode

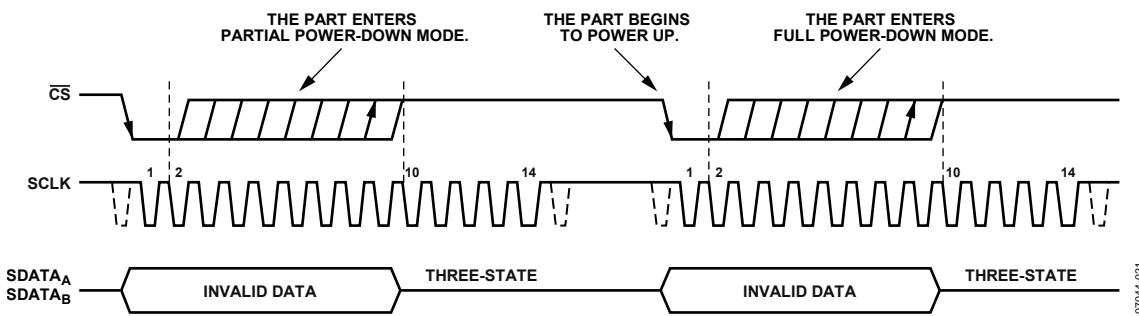

Figure 27. Entering Full Power-Down Mode

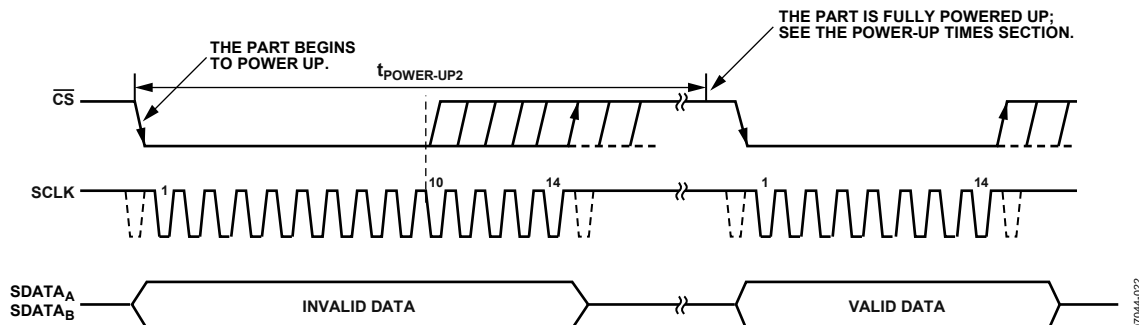

Figure 28. Exiting Full Power-Down Mode



## POWER-UP TIMES

The AD7352 has two power-down modes: partial power-down and full power-down, which are described in detail in the Normal Mode, Partial Power-Down Mode, and Full Power-Down Mode sections. This section deals with the power-up time required when coming out of any of these modes. Note that the recommended decoupling capacitors must be in place on the REF<sub>A</sub> and REF<sub>B</sub> pins for the power-up times to apply.

To power up from partial power-down mode, one dummy cycle is required. The device is fully powered up after approximately 333 ns have elapsed from the falling edge of  $\overline{CS}$ . When the partial power-up time has elapsed, the ADC is fully powered up, and the input signal is acquired properly. The quiet time,  $t_{\text{QUIET}}$ , must still be allowed from the point where the bus goes back into three-state after the dummy conversion to the next falling edge of  $\overline{CS}$ .

To power up from full power-down mode, approximately 6 ms should be allowed from the falling edge of  $\overline{CS}$ , shown in Figure 28 as  $t_{\text{POWER-UP2}}$ .

Note that during power-up from partial power-down mode, the track-and-hold, which is in hold mode while the part is powered down, returns to track mode after the first SCLK edge that the part receives after the falling edge of  $\overline{CS}$ .

When power supplies are first applied to the AD7352, the ADC can power up in either of the power-down modes or in normal mode. Because of this, it is best to allow a dummy cycle to elapse to ensure that the part is fully powered up before attempting a valid conversion. Likewise, if the part is to be kept in partial power-down mode immediately after the supplies are applied, then two dummy cycles must be initiated. The first dummy cycle must hold  $\overline{CS}$  low until after the 10<sup>th</sup> SCLK falling edge; in the second cycle,  $\overline{CS}$  must be brought high between the second and 10<sup>th</sup> SCLK falling edges (see Figure 25).

Alternatively, if the part is to be placed into full power-down mode when the supplies are applied, three dummy cycles must be initiated. The first dummy cycle must hold  $\overline{CS}$  low until after the 10<sup>th</sup> SCLK falling edge; the second and third dummy cycles place the part into full power-down mode (see Figure 27 and the Modes of Operation section).

## POWER vs. THROUGHPUT RATE

The power consumption of the AD7352 varies with the throughput rate. When using very slow throughput rates and as fast an SCLK frequency as possible, the various power-down options can be used to make significant power savings. However, the AD7352 quiescent current is low enough that, even without using the power-down options, there is a noticeable variation in power consumption with sampling rate. This is true whether a fixed SCLK value is used or it is scaled with the sampling rate. Figure 29 shows a plot of power vs. throughput rate when operating in normal mode for a fixed maximum SCLK frequency and a SCLK frequency that scales with the sampling rate. The internal reference was used for Figure 29.

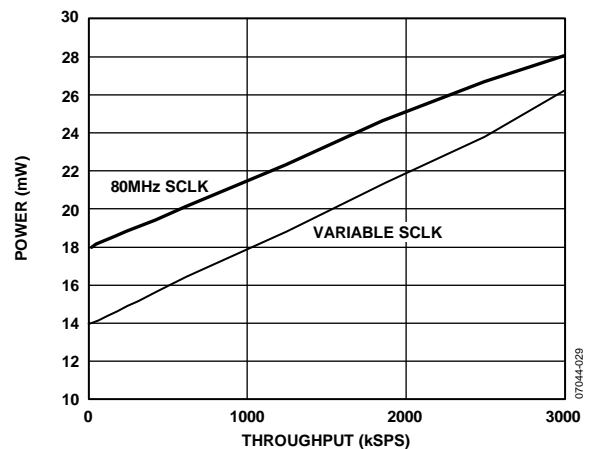

Figure 29. Power vs. Throughput Rate

### SERIAL INTERFACE

Figure 30 shows the detailed timing diagram for serial interfacing to the AD7352. The serial clock provides the conversion clock and controls the transfer of information from the AD7352 during conversion.

The  $\overline{CS}$  signal initiates the data transfer and conversion process. The falling edge of  $\overline{CS}$  puts the track and hold into hold mode, at which point the analog input is sampled and the bus is taken out of three-state. The conversion is also initiated at this point and requires a minimum of 14 SCLKs to complete. Once 13 SCLK falling edges have elapsed, the track and hold goes back into track on the next SCLK rising edge, as shown in Figure 30 at Point B. If a 16-bit data transfer is used on the AD7352, then two trailing zeros appear after the final LSB. On the rising edge of  $\overline{CS}$ , the conversion is terminated and  $SDATA_A$  and  $SDATA_B$  go back into three-state. If  $\overline{CS}$  is not brought high, but is instead held low for an additional 14 SCLK cycles, the data from the conversion on ADC B is output on  $SDATA_A$  (see Figure 31). Likewise, the data from the conversion on ADC A is

output on  $SDATA_B$ . In this case, the  $SDATA$  line in use goes back into three-state on the 32<sup>nd</sup> SCLK falling edge or the rising edge of  $\overline{CS}$ , whichever occurs first.

A minimum of 14 serial clock cycles is required to perform the conversion process and to access data from one conversion on either data line of the AD7352.  $\overline{CS}$  falling low provides the leading zero to be read in by the microcontroller or DSP. The remaining data is then clocked out by subsequent SCLK falling edges, beginning with a second leading zero. Thus, the first falling clock edge on the serial clock has the leading zero provided and also clocks out the second leading zero. The 12-bit result then follows with the final bit in the data transfer and is valid on the 14<sup>th</sup> falling edge (having been clocked out on the previous (13<sup>th</sup>) falling edge). In applications with a slower SCLK, it may be possible to read in data on each SCLK rising edge, depending on the SCLK frequency. With a slower SCLK, the first rising edge of SCLK after the  $\overline{CS}$  falling edge has the second leading zero provided, and the 13<sup>th</sup> rising SCLK edge has  $DB_0$  provided.

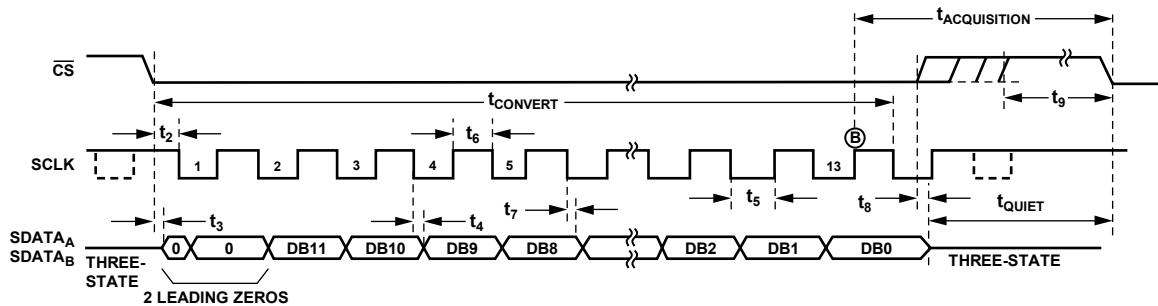

Figure 30. Serial Interface Timing Diagram

07044-024

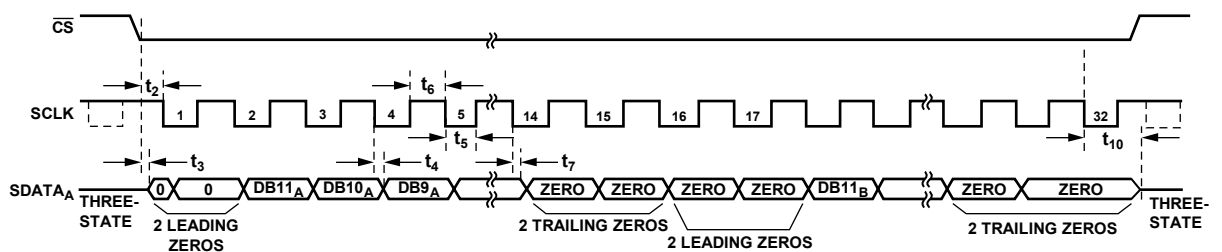

Figure 31. Reading Data from Both ADCs on One  $SDATA$  Line with 32 SCLKs

07044-025

## APPLICATION HINTS

### GROUNDING AND LAYOUT

The analog and digital supplies to the [AD7352](#) are independent and separately pinned out to minimize coupling between the analog and digital sections of the device. The printed circuit board (PCB) that houses the [AD7352](#) should be designed so that the analog and digital sections are separated and confined to certain areas of the board. This design facilitates the use of ground planes that can be easily separated.

To provide optimum shielding for ground planes, a minimum etch technique is generally best. The two AGND pins of the [AD7352](#) should be sunk in the AGND plane. The REFGND pin should also be sunk in the AGND plane. Digital and analog ground planes should be joined in only one place. If the [AD7352](#) is in a system in which multiple devices require an AGND and DGND connection, the connection should still be made at one point only, a star ground point should be established as close as possible to the ground pins on the [AD7352](#).

Avoid running digital lines under the device because this couples noise onto the die. Allow the analog ground planes to run under the [AD7352](#) to avoid noise coupling. The power supply lines to the [AD7352](#) should use as large a trace as possible to provide low impedance paths and reduce the effects of glitches on the power supply line.

To avoid radiating noise to other sections of the board, shield fast switching signals such as clocks, with digital ground, and never run clock signals near the analog inputs. Avoid crossover of digital and analog signals. To reduce the effects of feedthrough within the board, traces on opposite sides of the

board should run at right angles to each other. A microstrip technique is the best method but is not always possible with a double-sided board. In this technique, the component side of the board is dedicated to ground planes and signals are placed on the solder side.

Good decoupling is important; decouple all supplies with 10  $\mu\text{F}$  tantalum capacitors in parallel with 0.1  $\mu\text{F}$  capacitors to GND. To achieve the best results from these decoupling components, they must be placed as close as possible to the device, ideally right up against the device. The 0.1  $\mu\text{F}$  capacitor, (including the common ceramic types or surface-mount types) should have low effective series resistance (ESR) and effective series inductance (ESI). These low ESR and ESI capacitors provide a low impedance path to ground at high frequencies to handle transient currents due to logic switching.

### EVALUATING THE [AD7352](#) PERFORMANCE

The recommended layout for the [AD7352](#) is outlined in the evaluation board documentation. The evaluation board package includes a fully assembled and tested evaluation board, documentation, and software for controlling the board from the PC via the converter evaluation and development board (CED). The CED can be used in conjunction with the [AD7352](#) evaluation board (as well as many other Analog Devices, Inc., evaluation boards ending in the ED designator) to demonstrate/evaluate the ac and dc performance of the [AD7352](#).

The software allows the user to perform ac (fast Fourier transform) and dc (linearity) tests on the [AD7352](#). The software and documentation are on a CD shipped with the evaluation board.

## OUTLINE DIMENSIONS



COMPLIANT TO JEDEC STANDARDS MO-153-AB

Figure 32. 16-Lead Thin Shrink Small Outline Package [TSSOP]  
(RU-16)

Dimensions shown in millimeters

## ORDERING GUIDE

Model <sup>1,2,3</sup>	Temperature Range	Package Description	Package Option
AD7352BRUZ	-40°C to +85°C	16-Lead TSSOP	RU-16
AD7352BRUZ-500RL7	-40°C to +85°C	16-Lead TSSOP	RU-16
AD7352BRUZ-RL	-40°C to +85°C	16-Lead TSSOP	RU-16
AD7352YRUZ	-40°C to +125°C	16-Lead TSSOP	RU-16
AD7352YRUZ-500RL7	-40°C to +125°C	16-Lead TSSOP	RU-16
AD7352YRUZ-RL	-40°C to +125°C	16-Lead TSSOP	RU-16
EVAL-AD7352EDZ		Evaluation Board	
EVAL-CED1Z		Converter Evaluation and Development Board	

<sup>1</sup> Z = RoHS Compliant Part.

<sup>2</sup> The EVAL-AD7352EDZ board can be used as a standalone evaluation board or in conjunction with the EVAL-CED1Z board for evaluation/demonstration purposes.

<sup>3</sup> The EVAL-CED1Z board is a complete unit allowing a PC to control and communicate with all Analog Devices evaluation boards ending in the ED designator.



## Стандарт Электрон Связь

Мы молодая и активно развивающаяся компания в области поставок электронных компонентов. Мы поставляем электронные компоненты отечественного и импортного производства напрямую от производителей и с крупнейших складов мира.

Благодаря сотрудничеству с мировыми поставщиками мы осуществляем комплексные и плановые поставки широчайшего спектра электронных компонентов.

Собственная эффективная логистика и склад в обеспечивает надежную поставку продукции в точно указанные сроки по всей России.

Мы осуществляем техническую поддержку нашим клиентам и предпродажную проверку качества продукции. На все поставляемые продукты мы предоставляем гарантию .

Осуществляем поставки продукции под контролем ВП МО РФ на предприятия военно-промышленного комплекса России , а также работаем в рамках 275 ФЗ с открытием отдельных счетов в уполномоченном банке. Система менеджмента качества компании соответствует требованиям ГОСТ ISO 9001.

Минимальные сроки поставки, гибкие цены, неограниченный ассортимент и индивидуальный подход к клиентам являются основой для выстраивания долгосрочного и эффективного сотрудничества с предприятиями радиоэлектронной промышленности, предприятиями ВПК и научно-исследовательскими институтами России.

С нами вы становитесь еще успешнее!

### Наши контакты:

**Телефон:** +7 812 627 14 35

**Электронная почта:** [sales@st-electron.ru](mailto:sales@st-electron.ru)

**Адрес:** 198099, Санкт-Петербург,  
Промышленная ул, дом № 19, литера Н,  
помещение 100-Н Офис 331