

# UG298: Si5xxUC-EVB

## Universal Oscillator Evaluation Board

This document describes operation of the Silicon Laboratories Si5xxUC-EVB evaluation board designed to evaluate any of Silicon Labs' pin-controlled or I2C configurable Si5xx XOs or VCXOs. Three device sites are available to support one of either 5mm x 7mm, 3.2mm x 5mm, or 2.5mm x 3.2mm devices in either 4, 6, or 8 pin configurations. Selector switches make it easy to configure device control pins (pins 1, 2, 7, or 8) for proper operation without the use of jumpers. Similarly, XO device VDD voltage (3.3V, 2.5V, 1.8V) can be selected via switches based on either external +5V (for stand-alone operation) or micro USB sourced +5V USB operation. The EVB also features flexible output termination circuits and PCB layout optimized for superior signal integrity.

### KEY FEATURES

- Evaluation of any Silicon Labs XO or VCXO (Si51x, Si53x, Si54x, Si55x, Si56x, Si57x, Si59x)
- AC coupled differential/single-ended output clocks.
- Voltage control (Vc) port for VCXO evaluation.
- Switch selectable settings. No jumpers.
- External power or USB powered.
- Use stand-alone or with our [Programmable Oscillator Calculator SW tool](#)

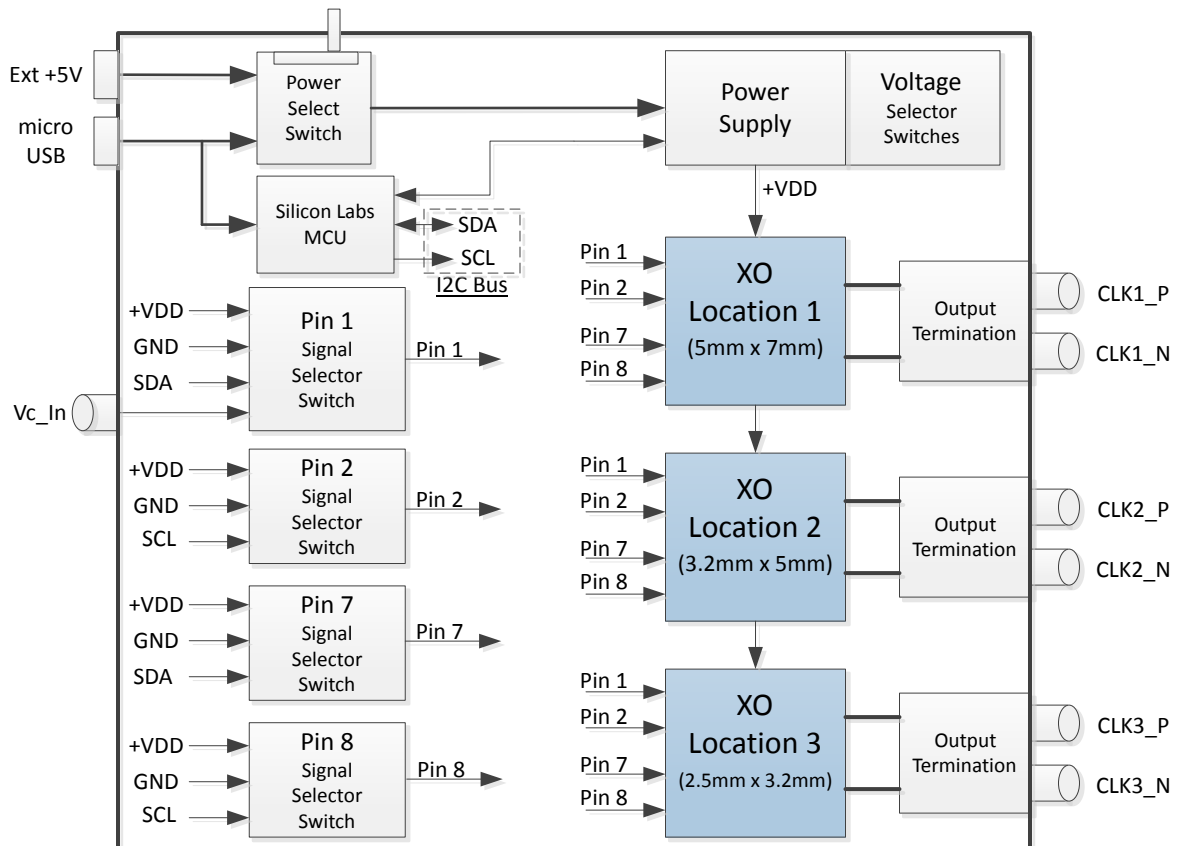

# Table of Contents

<b>1. Quick Start - Board Configuration Check List</b>	<b>3</b>
<b>2. Functional Description</b>	<b>4</b>
<b>3. General Operational Restrictions</b>	<b>5</b>
3.1 Evaluate Only a Single Device at a Time	5
<b>4. Power Supply and I2C Bus Control</b>	<b>6</b>
<b>5. Control Signal Switch Settings</b>	<b>7</b>
5.1 Oscillator Pin 1 Control DIP Switch (Pin_1_Ctrl)	8
5.2 Oscillator Pin 2 Control DIP Switch (Pin_2_Ctrl)	9
5.3 Oscillator Pin 7 Control DIP Switch (Pin_7_Ctrl)	10
5.4 Oscillator Pin 8 Control DIP Switch (Pin_8_Ctrl)	11
<b>6. Supported Devices - Stand-Alone Mode</b>	<b>12</b>
<b>7. Supported Devices - Software Controlled Mode - I<sup>2</sup>C</b>	<b>15</b>
<b>8. USB Port and External Powering</b>	<b>16</b>
<b>9. Output Clock Terminations</b>	<b>17</b>
<b>10. EVB Test Points and LEDs</b>	<b>18</b>
10.1 Test Points	18
10.2 LEDs	18
<b>11. VCXO Voltage Control Input Circuit</b>	<b>19</b>
<b>12. Programmable Oscillator Calculator Tool</b>	<b>20</b>
<b>13. Layout of Board</b>	<b>21</b>
<b>14. Si5xxUC-EVB Schematic</b>	<b>22</b>

## 1. Quick Start - Board Configuration Check List

Mount your oscillator device on the board at appropriate oscillator site location (U1, U2, or U3, but on only one location) if a device is not yet mounted.

1. Start with EVB board powered down/off.
2. Set DIP switches (described in Section [5. Control Signal Switch Settings](#)) for your specific device:
  - a. Look up your device as appropriate in the tables of Sections [6. Supported Devices - Stand-Alone Mode](#) or [7. Supported Devices - Software Controlled Mode - I<sup>2</sup>C](#).
  - b. Make DIP switch settings per table entry for pins 1,2,7,8 as appropriate. See Sections [6. Supported Devices - Stand-Alone Mode](#) or [7. Supported Devices - Software Controlled Mode - I<sup>2</sup>C](#).
3. Verify output termination is appropriate for your device (see Section [9. Output Clock Terminations](#) for more info).
4. Set +5V Select switch (SW5) based on how you will power the EVB, either via USB or via external +5V supply.
5. Connect power, either via USB port or external +5V power supply as chosen in previous step.
6. Output Clocks:
  - For pin controlled oscillators, clock output should be available on output SMAs of DUT site in use.
  - For I2C oscillators, run appropriate configuration software (e.g., [Programmable Oscillator Software tool](#)) and perform device configuration to get desired output clock.

## 2. Functional Description

The Si5xxUC-EVB is an evaluation board designed to support any Silicon Labs XO/VCXO device. The Si5xxUC-EVB is designed to operate in one of two general operational modes:

- **Stand-alone mode:** The stand-alone mode is for evaluation of **fixed output frequency or pin-controlled XO/VCXO devices** where I2C support is NOT required to operate or evaluate the device. Control of device pins, such as OE or FS, is done via on-board switches. In Stand-alone mode the on-board switches must be set according to the requirements of the device installed on the board. For example, if the installed device is a dual frequency part with output enable, the appropriate switches must be set to assert output enable (OE) and the frequency select pin (FS) to give the desired output frequency. Device VDD voltage can be set via on-board switches as well. Switch setting details for Stand-alone mode are shown in Section 4. [Power Supply and I2C Bus Control](#) (for power supply) and Section 5. [Control Signal Switch Settings](#) (for device pins).
- **Software controlled mode:** The software controlled mode is for use with PC-based software tools (such as our [Programmable Oscillator Calculator Tool](#)) to control/configure the device being evaluated via the device I2C bus. The software controlled mode is primarily intended for **I2C controlled XO/VCXO devices**. When using software controlled mode, some of the on-board switches must be placed in specific default settings to allow the on-board MCU to perform I<sup>2</sup>C control. Other switches must still be used on certain device signals, like output enable (OE). Switch setting details for software controlled mode are shown in Section 4. [Power Supply and I2C Bus Control](#) (for power supply & I2C) and Section 5. [Control Signal Switch Settings](#) (for device pins).

For each of the 3 device locations on the Si5XXUC-EVB, separate sets of SMA outputs and terminations are provided per XO “Device Under Test” (DUT) location even though only one device may be populated and used at a time (see Section 3. [General Operational Restrictions](#) below). Separate outputs and terminations per device site provides the best possible clock signal integrity for each DUT location.

### 3. General Operational Restrictions

#### 3.1 Evaluate Only a Single Device at a Time

**Note:** It is strongly recommended to populate only one device on the Si5xxUC-EVB board at a time. Carefully read the next paragraph for important information.

The Si5xxUC-EVB supports evaluation of a single device in one of three different DUT locations. Device sizes supported are 5mm x 7mm, 3.2mm x 5mm, or 2.5mm x 3.2mm. All device locations can support 4, 6, or 8 pin configurations, but only one device at a time should be installed in any one of the three locations on the Si5xxUC-EVB. This restriction is made to ensure no problems will occur due to potential signal crosstalk, power supply over-loading/coupling, or signal contention/loading between multiple devices. Do not simply remove power from a mounted device in an attempt to place it in an “unused”, but still mounted, state. Board control signals are wired in parallel to all 3 locations and a non-powered device may load control signals to a powered device under test. Please follow this “one device at a time” recommendation and only populate one device at a time.

## 4. Power Supply and I2C Bus Control

The power supply uses a linear voltage regulator to drop the +5V input supply voltage to one of the supported nominal VDD voltages of +3.3V, +2.5V, or +1.8 V. A switch is provided on the EVB (SW5) to select the +5V source for the voltage regulator as either the USB port +5V or an external +5V source. The EVB power supply supports operation in one of 2 general modes that correspond to the two operational EVB use cases.

- Stand-alone mode: Power can be sourced from either external supply or USB port, but software is not required and no EVB software tool should be actively connected to Si5XXUC-EVB when being used in Stand-alone mode. In Stand-alone mode the oscillator device VDD voltage is set via the “VDD\_DUT\_SEL” switch according to the voltage select table shown below. By default this switch is set to 1.8V and will need to be changed if evaluating a non-I2C oscillator with 2.5V or 3.3V VDD.
- Software controlled mode: Power can be sourced from either external power supply or USB port, but the Programmable Oscillator Software tool can be used to set the VDD voltage to the oscillator. In software controlled mode, “VDD\_DUT\_SEL” switches should remain set to 1.8V setting regardless of the desired VDD voltage.

The I2C Disable switch is typically set to the “Off” setting (to enable the on-board MCU to drive the I2C bus) unless the user is attempting to connect an external I2C master to communicate with the oscillator device. The I2C Disable control allows for disabling the on-board I2C buffer to disconnect the oscillator from the on-board MCU. This disconnection is useful if the user wishes to connect an external I2C bus master to communicate with the DUT.

### VDD\_DUT\_SEL

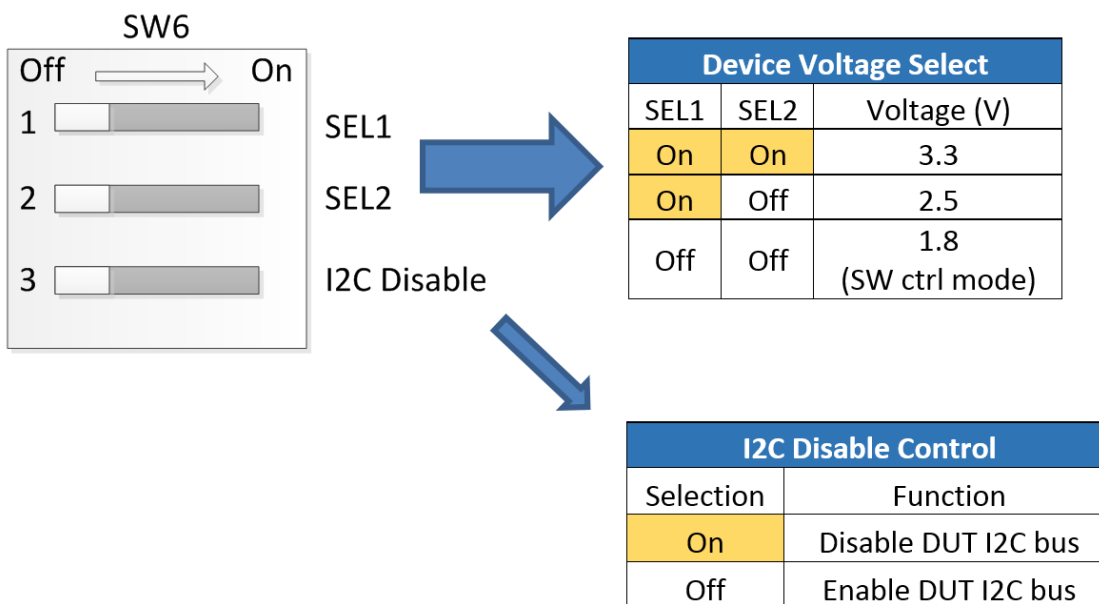

## 5. Control Signal Switch Settings

Four of the 5 on-board DIP switches (SW1, 2, 3, 4) are used for configuration of the EVB oscillator locations to match any standard oscillator pin-out. Using this DIP switch arrangement, the Si5xxUC-EVB can be configured to support all Silicon Labs oscillator devices. The oscillator device pins that can vary in function, depending on the device variant, are pins 1, 2, 7, and 8 as shown in the Device Pin-out Mapping table below. Pins 3, 4, 5, and 6 are typically fixed function pins that do not change with device variant.

**Note:** All device locations on the Si5xxUC-EVB can support up to 8 pin variant devices. Devices with fewer pins (4, 6 pin) can be installed in the same location and will fit within the 8 pin footprint.

Device Pin-out Mapping				
4 pin Device	6 pin Device	8 pin Device	DIP Switch	Function Options
1	1	1	Pin_1_Ctrl (SW1)	FS/OE/SDA/Vc
-	2	2	Pin_2_Ctrl (SW2)	FS/OE/SCL
2	3	3	-	GND <sup>1</sup>
3	4	4	-	Output <sup>1</sup>
-	5	5	-	Output <sup>1</sup>
4	6	6	-	VDD <sup>1</sup>
-	-	7	Pin_7_Ctrl (SW3)	FS/SDA
-	-	8	Pin_8_Ctrl (SW4)	FS/SCL
<b>Note:</b> 1. Fixed function pins				

Configuration details of each of the 4 variable pin function DIP switches is described in following sections. For devices that may not utilize all 4 of the variable pin function switches, the corresponding unused DIP switch can be set to the NC setting (all Off position). Make sure to make the following switch settings with the Si5xxUC-EVB powered down. Once all are set appropriately, the board may be powered on.

### 5.1 Oscillator Pin 1 Control DIP Switch (Pin\_1\_Ctrl)

The pin 1 control DIP switch allows oscillator pin 1 to be driven from any of these 4 sources.

1. High (VDD) level
2. Low (GND) level
3. I2C bus SDA signal
4. External control voltage Vc (for VCXO applications)

**Note:** The 4 signal sources listed above are connected on separate pins on left side of the switch and all pins on right side are tied together (common) and then connect to pin 1 of the oscillator. **This means that only one (1) of the switches in this DIP switch bank can be in the ON position at a time.** Switching more than 1 switch to the on position at a time may cause undesired behavior. All switches can be set to OFF position to effectively isolate pin 1 from any signal source and is the No Connect (NC) state.

To determine the required Pin 1 switch settings for your specific device, please refer to the Supported Device Tables in Chapter 6. [Supported Devices - Stand-Alone Mode](#) and Chapter 7. [Supported Devices - Software Controlled Mode - I<sup>2</sup>C](#).

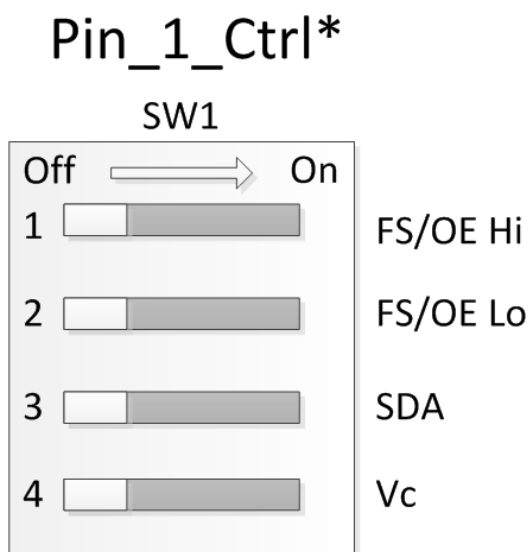

Pin 1 DIP Switch (4, 6, or 8 pin DUT)				
1	2	3	4	Pin 1 Signal
Off	Off	Off	Off	NC
On	Off	Off	Off	FS/OE high
Off	On	Off	Off	FS/OE low
Off	Off	On	Off	SDA
Off	Off	Off	On	Vc



## 5.2 Oscillator Pin 2 Control DIP Switch (Pin\_2\_Ctrl)

This DIP switch allows oscillator pin 2 to be driven from 1 of 3 sources.

1. High (VDD) level
2. Low (GND) level
3. I2C bus SCL signal

**Note:** The 3 signal sources listed above are located on separate pins on the left side of the switch and all pins on the right side are tied together (common) and then connect to pin 2 of the oscillator. **This means that only one (1) of the switches in this DIP switch bank can be in the ON position at a time.** Switching more than 1 switch to the ON position at a time may cause undesired behavior. All switches set to OFF position effectively isolates pin 2 from any signal source and is the No Connect (NC) state.

To determine the required Pin 2 switch settings for your specific device, please refer to the Supported Device Tables in Chapter 6. [Supported Devices - Stand-Alone Mode](#) and Chapter 7. [Supported Devices - Software Controlled Mode - I<sup>2</sup>C](#).

# Pin\_2\_Ctrl\*

SW2

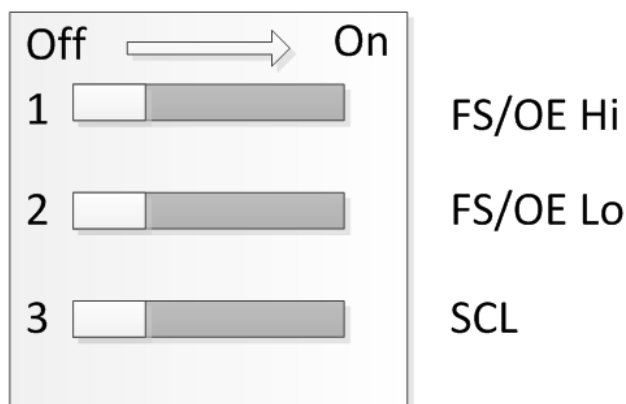

Pin 2 DIP Switch (6 or 8 pin DUT)			
1	2	3	Pin 2 Signal
Off	Off	Off	NC
On	Off	Off	FS/OE high
Off	On	Off	FS/OE low
Off	Off	On	SCL

### 5.3 Oscillator Pin 7 Control DIP Switch (Pin\_7\_Ctrl)

This DIP switch allows oscillator pin 7 to be driven from 1 of 3 sources.

1. High (VDD) level
2. Low (GND) level
3. I2C bus SDA signal

**Note:** The 3 signal sources listed above are located on separate pins on the left side of the switch and all pins on the right side are tied together (common) and then connect to pin 7 of the oscillator. **This means that only one (1) of the switches in this DIP switch bank can be in the ON position at a time.** Switching more than 1 switch to the ON position at a time may cause undesired behavior. All switches set to OFF position effectively isolates pin 7 from any signal source and is the No Connect (NC) state.

To determine the required Pin 7 switch settings for your specific device, please refer to the Supported Device Tables in Chapter 6. [Supported Devices - Stand-Alone Mode](#) and Chapter 7. [Supported Devices - Software Controlled Mode - I<sup>2</sup>C](#).

## Pin\_7\_Ctrl\*

SW3

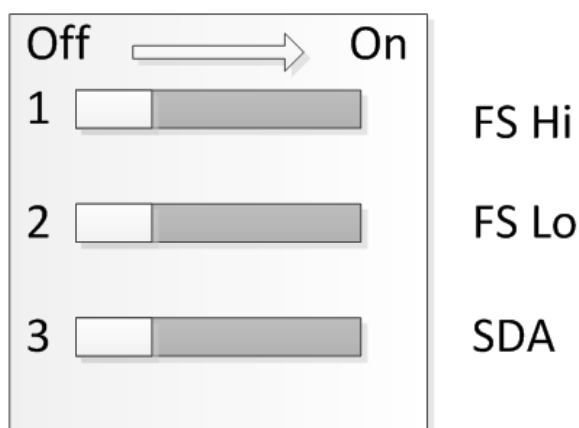

Pin 7 DIP Switch (8 pin DUT)			
1	2	3	Pin 7 Signal
Off	Off	Off	NC
On	Off	Off	FS high
Off	On	Off	FS low
Off	Off	On	SDA

### 5.4 Oscillator Pin 8 Control DIP Switch (Pin\_8\_Ctrl)

This DIP switch allows oscillator pin 8 to be driven from 1 of 3 sources.

1. 1. High (VDD) level
2. 2. Low (GND) level
3. 3. I2C bus SCL signal

**Note:** The 3 signal sources listed above are located on separate pins on the left side of the switch and all pins on the right side are tied together (common) and then connect to pin 8 of the oscillator. **This means that only one (1) of the switches in this DIP switch bank can be in the ON position at a time.** Switching more than 1 switch to the ON position at a time may cause undesired behavior. All switches set to OFF position effectively isolates pin 8 from any signal source and is the No Connect (NC) state.

To determine the required Pin 8 switch settings for your specific device, please refer to the Supported Device Tables in Chapter 6. [Supported Devices - Stand-Alone Mode](#) and Chapter 7. [Supported Devices - Software Controlled Mode - I<sup>2</sup>C](#).

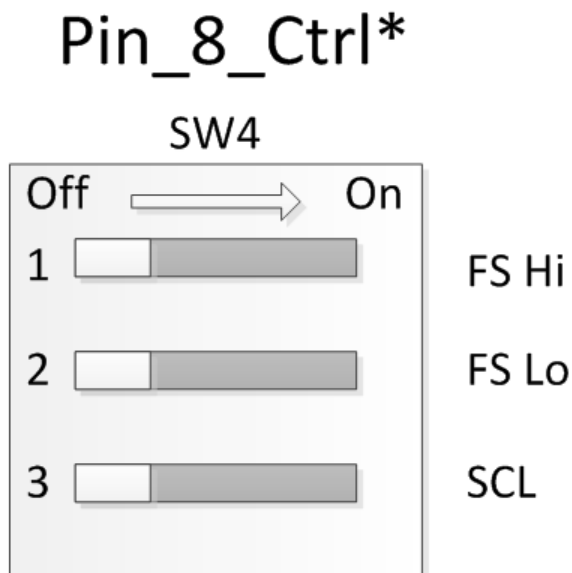

Pin 8 DIP Switch (8 pin DUT)			
1	2	3	Pin 8 Signal
Off	Off	Off	NC
On	Off	Off	FS high
Off	On	Off	FS low
Off	Off	On	SCL

## 6. Supported Devices - Stand-Alone Mode

If using the Si5XXUC-EVB with a device that is either fixed frequency or has pin-controlled output frequency, this “Stand-alone mode” section should be used to configure the EVB.

If you have a device installed that utilizes the I2C bus for making frequency or other changes to the device, please refer to Section 7. [Supported Devices - Software Controlled Mode - I<sup>2</sup>C](#).

The tables below show pin controlled XO and VCXO devices supported by the Si5xxUC-EVB along with possible package sizes and control pin mapping. The control pin mapping can be used to determine the corresponding switch settings on the Si5xxUC-EVB.

**Table 6.1. Pin Controlled XOs**

SiLabs Device	Type	# Freqs	# pins	Pkg sizes (mm x mm)	Pin 1 Control	Pin 2 Control	Pin 7 Control	Pin 8 Control	Pin 4 Out-put	Pin 5 Out-put
Si560	XO	Single	6	5x7, 3.2x5	OE/NC	NC/OE	-	-	CLK+	CLK-
Si561	XO	Dual	6	5x7, 3.2x5	OE/FS	FS/OE	-	-	CLK+	CLK-
Si562	XO	Quad	8	5x7, 3.2x5	OE/NC	NC/OE	FS1	FS0	CLK+	CLK-
Si564	XO	Single/ Dual/ Quad (or I <sup>2</sup> C)	8	5x7, 3.2x5	OE/NC/FS	OE/NC/FS	SDA/FS1	SCL/FS0	CLK+	CLK-
Si540	XO	Single	6	5x7, 3.2x5, 2.5x3.2	OE/NC	NC/OE	-	-	CLK+	CLK-
Si541	XO	Dual	6	5x7, 3.2x5, 2.5x3.2	OE/FS	FS/OE	-	-	CLK+	CLK-
Si542	XO	Quad	8	5x7, 3.2x5, 2.5x3.2	OE/NC	NC/OE	FS1	FS0	CLK+	CLK-
Si544	XO	Single/ Dual/ Quad (or I2C)	8	5x7, 3.2x5, 2.5x3.2	OE/NC/FS	OE/NC/FS	SDA/FS1	SCL/FS0	CLK+	CLK-
Si545	XO	Single	6	5x7, 3.2x5	OE/NC	NC/OE	-	-	CLK+	CLK-
Si546	XO	Dual	6	5x7, 3.2x5	OE/FS	FS/OE	-	-	CLK+	CLK-
Si547	XO	Quad	8	5x7, 3.2x5	OE/NC	NC/OE	FS1	FS0	CLK+	CLK-
Si549	XO	Single/ Dual/ Quad (or I2C)	8	5x7, 3.2x5	OE/NC/FS	OE/NC/FS	SDA/FS1	SCL/FS0	CLK+	CLK-
Si535	XO	Single	6	5x7	NC	OE	-	-	CLK+	CLK-
Si536	XO	Single	6	5x7	OE	NC	-	-	CLK+	CLK-
Si530	XO	Single (Diff)	6	5x7	NC	OE	-	-	CLK+	CLK-
Si530	XO	Single (CMOS)	6	5x7	OE	NC	-	-	CLK	NC
Si531	XO	Single	6	5x7	OE	NC	-	-	CLK+	CLK-
Si532	XO	Dual (Diff)	6	5x7	FS	OE	-	-	CLK+	CLK-
Si532	XO	Dual (CMOS)	6	5x7	FS	OE	-	-	CLK	NC

SiLabs Device	Type	# Freqs	# pins	Pkg sizes (mm x mm)	Pin 1 Control	Pin 2 Control	Pin 7 Control	Pin 8 Control	Pin 4 Output	Pin 5 Output
Si533	XO	Dual (Diff)	6	5x7	OE	FS	-	-	CLK+	CLK-
Si533	XO	Dual (CMOS)	6	5x7	OE	FS	-	-	CLK	NC
Si534	XO	Quad (Diff)	8	5x7	NC	OE	FS1	FS0	CLK+	CLK-
Si534	XO	Quad (CMOS)	8	5x7	NC	OE	FS1	FS0	CLK	NC
Si590	XO	Single (Diff)	6	5x7, 3.2x5	NC	OE	-	-	CLK+	CLK-
Si590	XO	Single (CMOS)	6	5x7, 3.2x5	OE	NC	-	-	CLK	NC
Si591	XO	Single	6	5x7, 3.2x5	OE	NC	-	-	CLK+	CLK-
Si510	XO	Single (CMOS)	4*	5x7, 3.2x5, 2.5x3.2	OE*	-	-	-	CLK*	-
Si510	XO	Single (Diff)	6	5x7, 3.2x5, 2.5x3.2	NC	OE	-	-	CLK+	CLK-
Si511	XO	Single	6	5x7, 3.2x5, 2.5x3.2	OE	NC	-	-	CLK+	CLK-
Si512	XO	Dual (CMOS)	6	5x7, 3.2x5, 2.5x3.2	FS	OE	-	-	CLK	NC
Si512	XO	Dual (Diff)	6	5x7, 3.2x5, 2.5x3.2	FS	OE	-	-	CLK+	CLK-
Si513	XO	Dual (CMOS)	6	5x7, 3.2x5, 2.5x3.2	OE	FS	-	-	CLK	NC
Si513	XO	Dual (Diff)	6	5x7, 3.2x5, 2.5x3.2	OE	FS	-	-	CLK+	CLK-

4 pin device	Function	6/8 pin device
1	NC or OE	1
2	Gnd	3
3	Output	4
4	Vdd	6

**Table 6.2. Pin Controlled VCXOs**

SiLabs Device	Type	# Freqs	# pins	Pkg sizes (mm x mm)	Pin 1 Control	Pin 2 Control	Pin 7 Control	Pin 8 Control	Pin 4 Output	Pin 5 Output
Si565	VCXO	Single	6	5x7, 3.2x5	Vc	OE	-	-	CLK+	CLK-
Si566	VCXO	Dual	6	5x7, 3.2x5	Vc	FS	-	-	CLK+	CLK-
Si567	VCXO	Quad	8	5x7, 3.2x5	Vc	OE	FS1	FS0	CLK+	CLK-
Si569	VCXO	Single/ Dual (or I <sup>2</sup> C)	8	5x7, 3.2x5	Vc	OE/FS	SDA	SCL	CLK+	CLK-
Si550	VCXO	Single	6	5x7	Vc	OE	-	-	CLK+	CLK-
Si552	VCXO	Dual	6	5x7	Vc	FS	-	-	CLK+	CLK-
Si554	VCXO	Quad	8	5x7	Vc	OE	FS1	FS0	CLK+	CLK-
Si595	VCXO	Single	6	5x7, 3.2x5	Vc	OE	-	-	CLK+	CLK-
Si596	VCXO	Dual	6	5x7, 3.2x5	Vc	FS	-	-	CLK+	CLK-
Si597	VCXO	Quad	8	5x7	Vc	OE	FS1	FS0	CLK+	CLK-
Si515	VCXO	Single (CMOS)	6	5x7, 3.2x5, 2.5x3.2	Vc	OE	-	-	CLK	NC
Si515	VCXO	Single (Diff)	6	5x7, 3.2x5, 2.5x3.2	Vc	OE	-	-	CLK+	CLK-
Si516	VCXO	Dual (CMOS)	6	5x7, 3.2x5, 2.5x3.2	Vc	FS	-	-	CLK	NC
Si516	VCXO	Dual (Diff)	6	5x7, 3.2x5, 2.5x3.2	Vc	FS	-	-	CLK+	CLK-

## 7. Supported Devices - Software Controlled Mode - I<sup>2</sup>C

If using the Si5XXUC-EVB with a device that utilizes the I2C bus for making frequency or other changes to the device, this “software controlled mode” section should be used to configure the EVB.

If you have a device installed that is either fixed frequency or has pin-controlled output frequency, refer to Section 6. [Supported Devices - Stand-Alone Mode](#).

The tables below show I2C XO and I2C VCXO devices supported by the Si5xxUC-EVB along with possible package sizes and control pin mapping. The control pin mapping can be used to determine the corresponding switch settings on the Si5xxUC-EVB when using software controlled mode.

**Table 7.1. I<sup>2</sup>C XOs**

SiLabs Device	Type	# Freqs	# pins	Pkg sizes (mm x mm)	Pin 1 Control	Pin 2 Control	Pin 7 Control	Pin 8 Control	Pin 4 Output	Pin 5 Output
Si564	XO	I2C or (Single/Dual/Quad)	8	5x7, 3.2x5	OE/NC/FS	OE/NC/FS	SDA/FS1	SCL/FS0	CLK+	CLK-
Si544	XO	I2C or (Single/Dual/Quad)	8	5x7, 3.2x5, 2.5x3.2	OE/NC/FS	OE/NC/FS	SDA/FS1	SCL/FS0	CLK+	CLK-
Si549	XO	I2C or (Single/Dual/Quad)	8	5x7, 3.2x5	OE/NC/FS	OE/NC/FS	SDA/FS1	SCL/FS0	CLK+	CLK-
Si570	XO	I2C	8	5x7	NC	OE	SDA	SCL	CLK+	CLK-
Si598	XO	I2C	8	5x7	NC	OE	SDA	SCL	CLK+	CLK-
Si514	XO	I2C	6	5x7, 3.2x5, 2.5x3.2	SDA	SCL	-	-	CLK+	CLK-

**Table 7.2. I2C VCXOs**

SiLabs Device	Type	# Freqs	# pins	Pkg sizes (mm x mm)	Pin 1 Control	Pin 2 Control	Pin 7 Control	Pin 8 Control	Pin 4 Output	Pin 5 Output
Si569	VCXO	I2C or (Single/Dual)	8	5x7, 3.2x5	Vc	OE/FS	SDA	SCL	CLK+	CLK-
Si571	VCXO	I2C	8	5x7	Vc	OE	SDA	SCL	CLK+	CLK-
Si599	VCXO	I2C	8	5x7	Vc	OE	SDA	SCL	CLK+	CLK-

## 8. USB Port and External Powering

The USB port on the Si5xxUC-EVB utilizes a micro-USB connector that is located on the left edge of the board on bottom side. A 2 meter micro USB cable is provided with the EVB kit. Any micro USB cable can be used that supports full USB connectivity.

If powering the EVB via the USB port, make sure switch SW5 is in the “USB” position. If properly connected to a live USB port, the green VBUS\_5V should illuminate.

If powering the board via an external +5V power supply, make sure SW5 is in the “EXT” position. Once +5V is connected to the board via the +5V\_EXT connections, the green +5V\_EXT LED should illuminate.



## 9. Output Clock Terminations

The drawing in the figure below shows the default output termination circuit for CLK1 output of the Si5xxUC-EVB. This default source termination is for typical 3.3V **LVPECL**. CLK2 and CLK3 are also terminated similarly for 3.3V LVPECL. If not using LVPECL, this termination circuit may require component modification. The following table gives examples of recommended output termination components for various output formats when using Si51x, Si53x, Si54x, Si55x, Si56x, Si57x, and Si59x devices, but **always refer to the specific device datasheet and/or appropriate application note for details of required output source termination for the specific device being evaluated.**

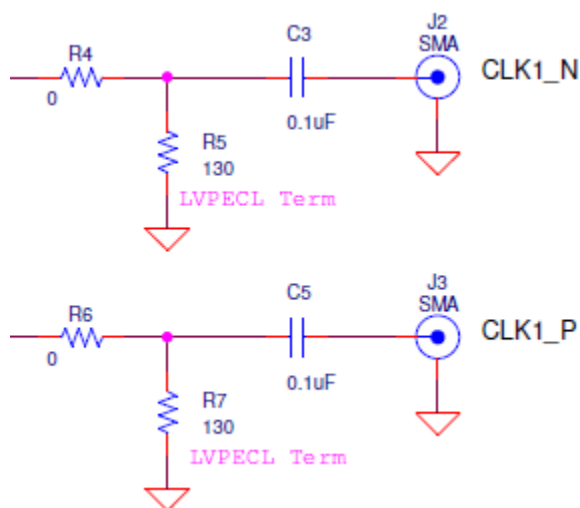

Figure 9.1. CLK1 Output Default Terminations

Table 9.1. Example Output Clock Source Terminations (Si51x, Si53x, Si54x, Si55x, Si56x, Si57x, and Si59x only)

Output Format	Series Resistor Position (e.g., R4, R6)	Parallel Resistor Position (e.g., R5, R7)	Series Capacitor Position (e.g., C3, C5)
LVPECL 3.3V: AC coupled	0 $\Omega$	130 $\Omega$	0.1 $\mu$ F
LVPECL 2.5V: AC coupled	0 $\Omega$	90 $\Omega$	0.1 $\mu$ F
LVPECL: DC coupled	0 $\Omega$	Remove	replace w/0 $\Omega$
LVDS : AC coupled	0 $\Omega$	Remove	0.1 $\mu$ F
LVDS : DC coupled	0 $\Omega$	Remove	replace w/0 $\Omega$
HCSL	0 $\Omega$	Remove	replace w/0 $\Omega$
CML	0 $\Omega$	Remove	0.1 $\mu$ F
LVC MOS : AC coupled	0 $\Omega$	Remove	0.1 $\mu$ F
LVC MOS : DC coupled	0 $\Omega$	Remove	replace w/10 $\Omega$

## 10. EVB Test Points and LEDs

### 10.1 Test Points

The Si5xxUC-EVB has many test points that are useful for probing various nodes and/or making connections to external test equipment. **Please refer to the schematic for functions of the various test points.**

One set of test points in particular provides oscillator current sense capability and is shown in the drawing below. These two test points allow an external voltage measurement to be taken across the two test points to determine the current being used by the oscillator. Since the resistor value is 1  $\Omega$ , the voltage measured across these 2 test points corresponds to the current through the resistor. For example, if the measured voltage is 75 mV, the current flow is 75 mA. Each oscillator site has this current sense circuit.

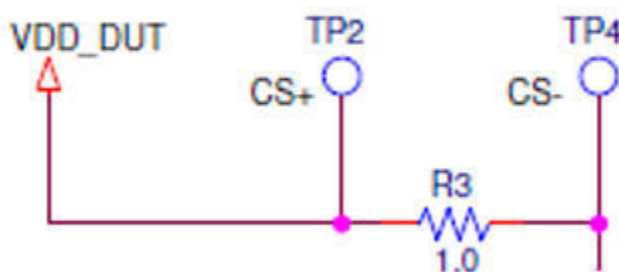

Figure 10.1. Current Sense Test Points

### 10.2 LEDs

The Si5xxUC-EVB has 5 status LEDs as shown in table below. The board silkscreen identifies each LED.

Table 10.1. Status LEDs

LED name	Color	Location	Description
+5V_EXT	Green	D1	External +5V source is present (independent of +5V_SELECT (SW5) switch setting)
VBUS_5V	Green	D5	USB +5V is present (independent of +5V_SELECT (SW5) switch setting)
VDD_3.3	Green	D4	On-board MCU 3.3V is present
USB_ACT	Red	D3	USB port activity
Aux	Red	D2	TBD (spare)

## 11. VCXO Voltage Control Input Circuit

The drawing below shows the VCXO control voltage input (VC\_IN) circuit used for evaluation of VCXOs. The VCXO control voltage can be applied using the J1 SMA connector, or using TP3/TP6. A simple RC circuit is included to low-pass filter any noise on the input. The RC circuit components can be removed or modified as required for your application.

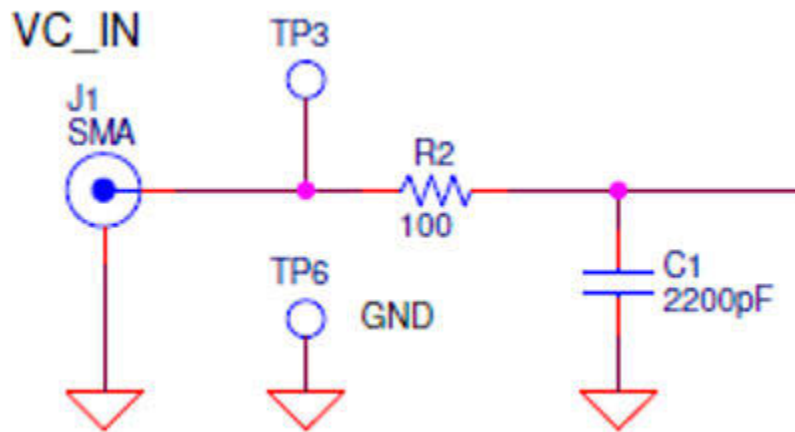
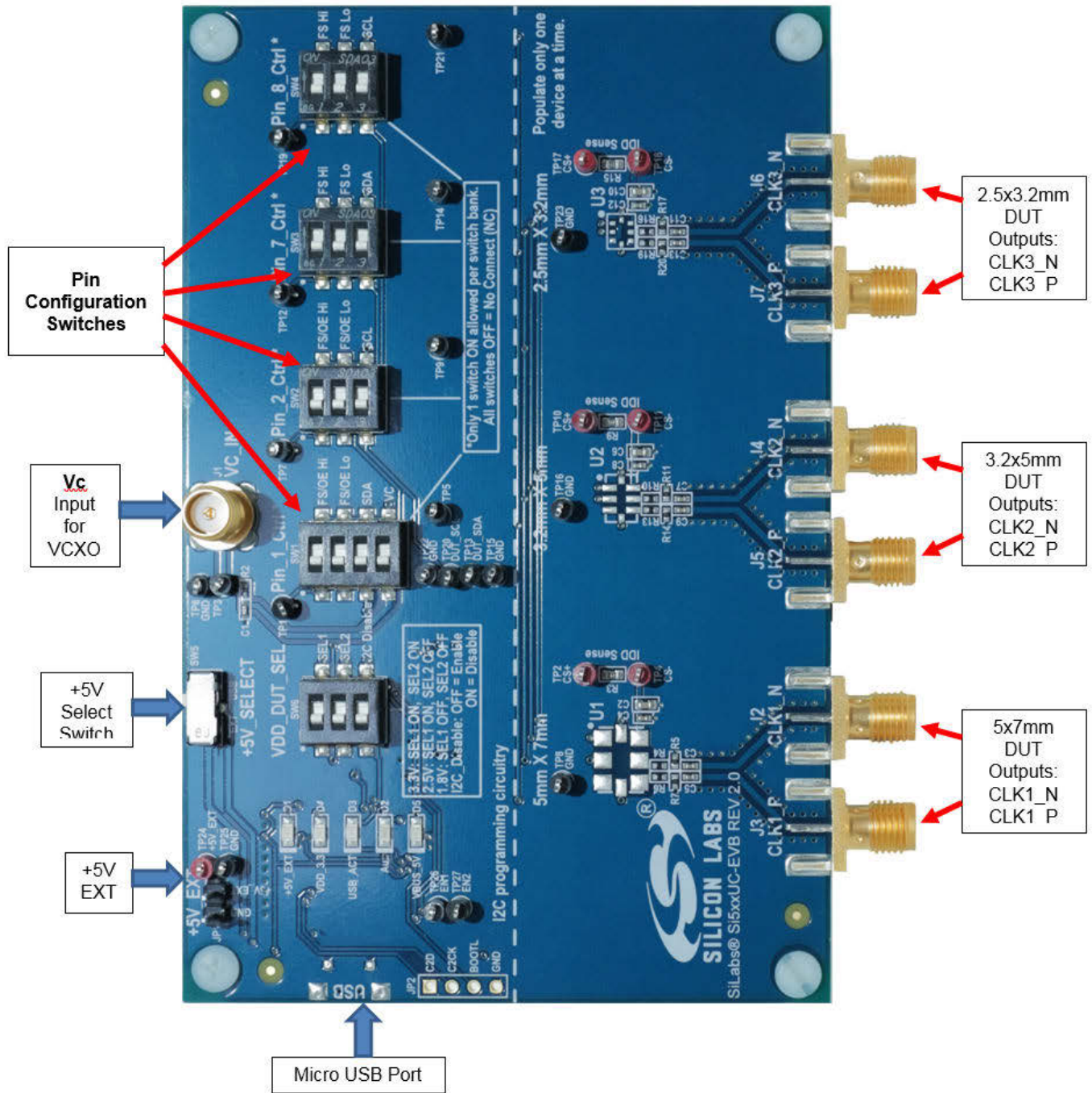

Figure 11.1. VCXO Control Voltage Input "VC\_IN"

## 12. Programmable Oscillator Calculator Tool

The Programmable Oscillator Software Tool can be used with the Si5xxUC-EVB. This tool and corresponding Programmable Oscillator Software Tool User's Guide can be found [www.silabs.com/oscillator-tools](http://www.silabs.com/oscillator-tools).

### 13. Layout of Board



# 14. Si5xxUC-EVB Schematic

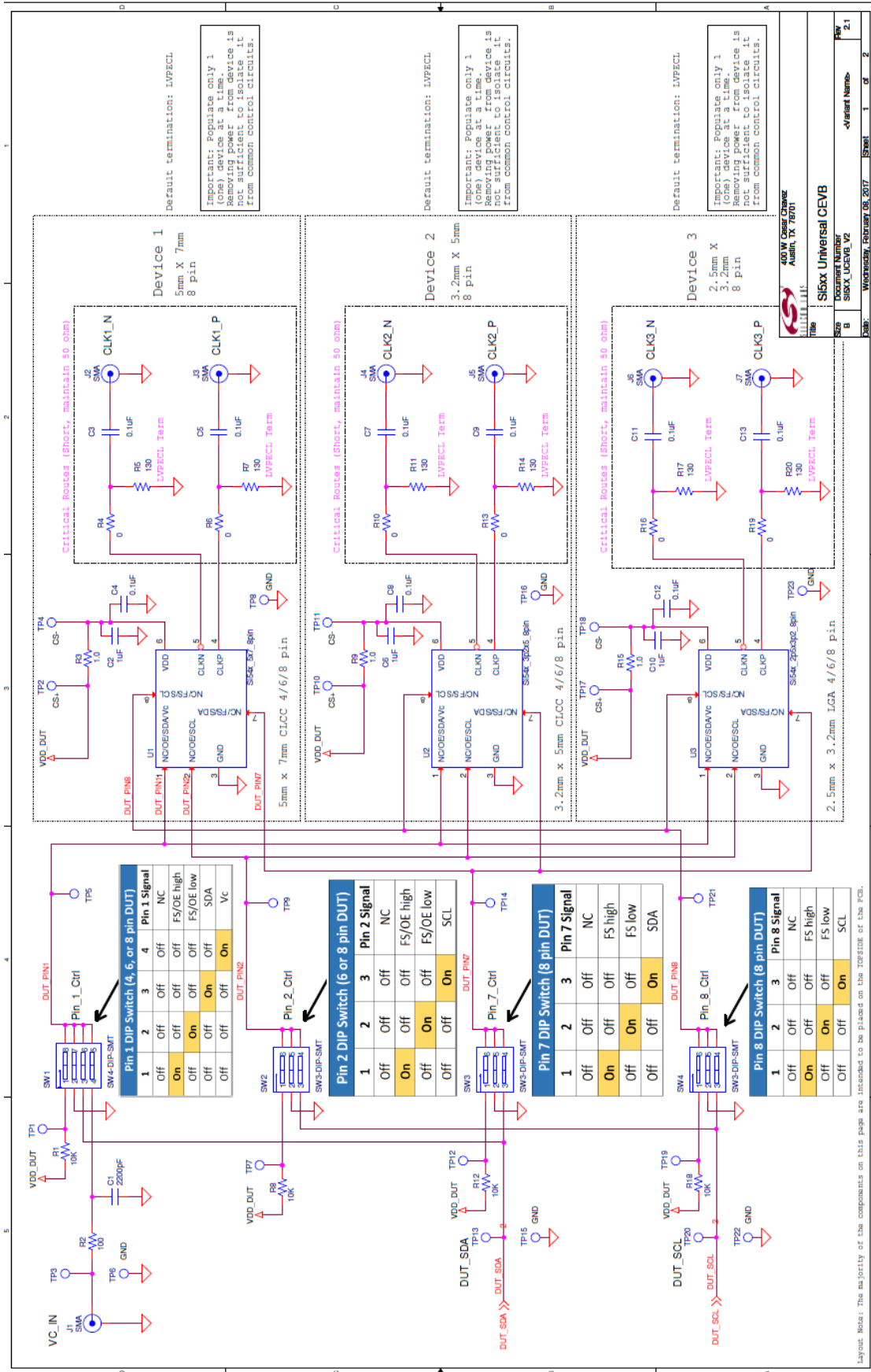

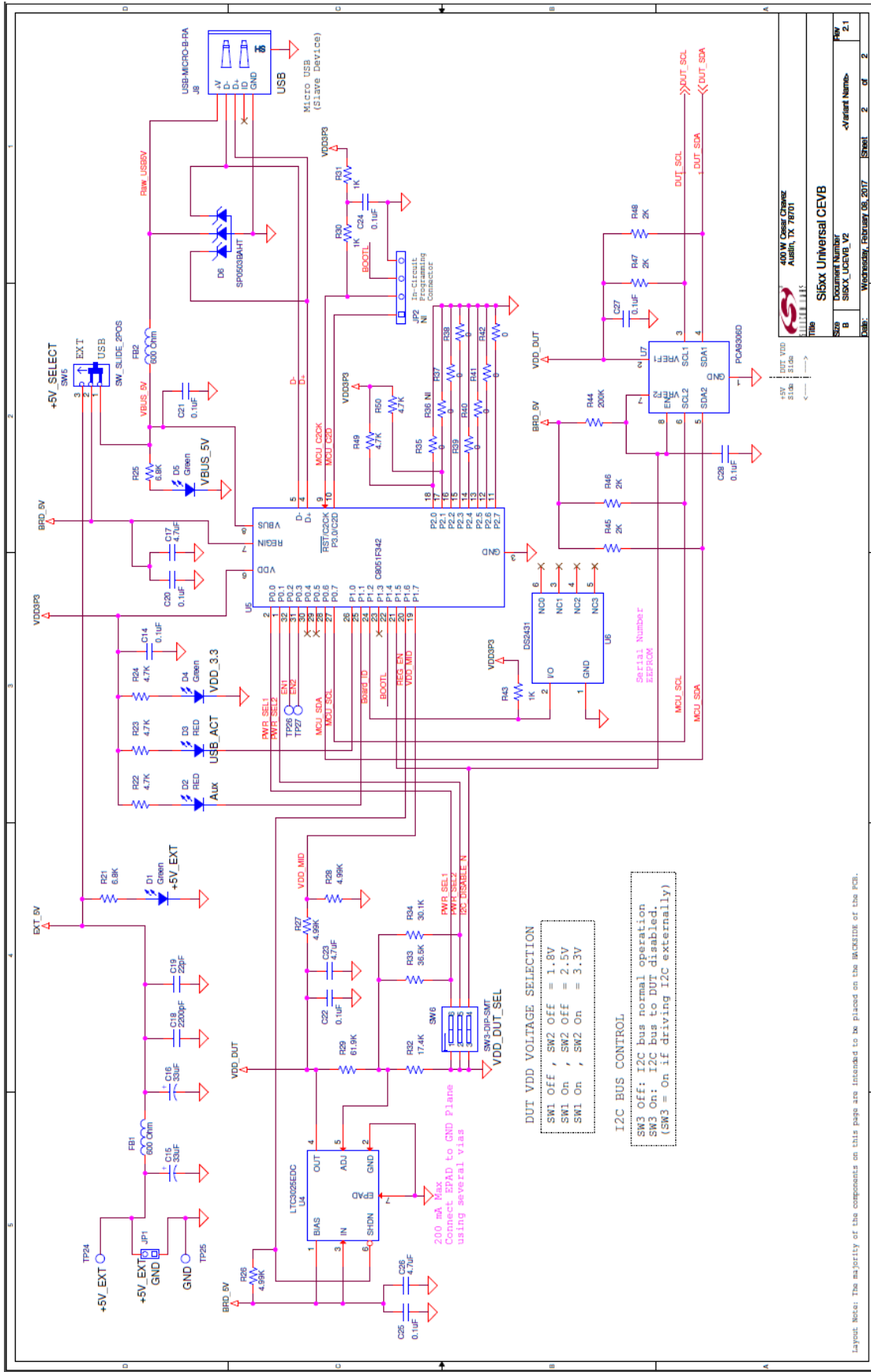

**DUT VDD VOLTAGE SELECTION**

- SW1 Off, SW2 Off = 1.8V
- SW1 On, SW2 Off = 2.5V
- SW1 On, SW2 On = 3.3V

**I2C BUS CONTROL**

- SW3 Off: I2C bus normal operation
- SW3 On: I2C bus to DUT disabled.
- (SW3 = On if driving I2C externally)

Layout Note: The majority of the components on this page are intended to be placed on the BACKSIDE of the PCB.

The SiFive Universal CEVB	
Document Number Si5xx_UC_EVB_V2	<Variant Name> Rev 2.1
Date Wednesday, February 08, 2017	Sheet 2 of 2



## ClockBuilder Pro

One-click access to Timing tools, documentation, software, source code libraries & more. Available for Windows and iOS (CBGo only).

[www.silabs.com/CBPro](http://www.silabs.com/CBPro)



Timing Portfolio

[www.silabs.com/timing](http://www.silabs.com/timing)



SW/HW

[www.silabs.com/CBPro](http://www.silabs.com/CBPro)



Quality

[www.silabs.com/quality](http://www.silabs.com/quality)



Support and Community

[community.silabs.com](http://community.silabs.com)

### Disclaimer

Silicon Labs intends to provide customers with the latest, accurate, and in-depth documentation of all peripherals and modules available for system and software implementers using or intending to use the Silicon Labs products. Characterization data, available modules and peripherals, memory sizes and memory addresses refer to each specific device, and "Typical" parameters provided can and do vary in different applications. Application examples described herein are for illustrative purposes only. Silicon Labs reserves the right to make changes without further notice to the product information, specifications, and descriptions herein, and does not give warranties as to the accuracy or completeness of the included information. Without prior notification, Silicon Labs may update product firmware during the manufacturing process for security or reliability reasons. Such changes will not alter the specifications or the performance of the product. Silicon Labs shall have no liability for the consequences of use of the information supplied in this document. This document does not imply or expressly grant any license to design or fabricate any integrated circuits. The products are not designed or authorized to be used within any FDA Class III devices, applications for which FDA premarket approval is required or Life Support Systems without the specific written consent of Silicon Labs. A "Life Support System" is any product or system intended to support or sustain life and/or health, which, if it fails, can be reasonably expected to result in significant personal injury or death. Silicon Labs products are not designed or authorized for military applications. Silicon Labs products shall under no circumstances be used in weapons of mass destruction including (but not limited to) nuclear, biological or chemical weapons, or missiles capable of delivering such weapons. Silicon Labs disclaims all express and implied warranties and shall not be responsible or liable for any injuries or damages related to use of a Silicon Labs product in such unauthorized applications.

### Trademark Information

Silicon Laboratories Inc.®, Silicon Laboratories®, Silicon Labs®, SiLabs® and the Silicon Labs logo®, Bluegiga®, Bluegiga Logo®, ClockBuilder®, CMEMS®, DSPLL®, EFM®, EFM32®, EFR®, Ember®, Energy Micro, Energy Micro logo and combinations thereof, "the world's most energy friendly microcontrollers", Ember®, EZLink®, EZRadio®, EZRadioPRO®, Gecko®, Gecko OS, Gecko OS Studio, ISOModem®, Precision32®, ProSLIC®, Simplicity Studio®, SiPHY®, Telegesis, the Telegesis Logo®, USBXpress®, Zentri, the Zentri logo and Zentri DMS, Z-Wave®, and others are trademarks or registered trademarks of Silicon Labs. ARM, CORTEX, Cortex-M3 and THUMB are trademarks or registered trademarks of ARM Holdings. Keil is a registered trademark of ARM Limited. Wi-Fi is a registered trademark of the Wi-Fi Alliance. All other products or brand names mentioned herein are trademarks of their respective holders.



Silicon Laboratories Inc.  
400 West Cesar Chavez  
Austin, TX 78701  
USA

<http://www.silabs.com>





**Стандарт  
Электрон  
Связь**

Мы молодая и активно развивающаяся компания в области поставок электронных компонентов. Мы поставляем электронные компоненты отечественного и импортного производства напрямую от производителей и с крупнейших складов мира.

Благодаря сотрудничеству с мировыми поставщиками мы осуществляем комплексные и плановые поставки широчайшего спектра электронных компонентов.

Собственная эффективная логистика и склад в обеспечивает надежную поставку продукции в точно указанные сроки по всей России.

Мы осуществляем техническую поддержку нашим клиентам и предпродажную проверку качества продукции. На все поставляемые продукты мы предоставляем гарантию .

Осуществляем поставки продукции под контролем ВП МО РФ на предприятия военно-промышленного комплекса России , а также работаем в рамках 275 ФЗ с открытием отдельных счетов в уполномоченном банке. Система менеджмента качества компании соответствует требованиям ГОСТ ISO 9001.

Минимальные сроки поставки, гибкие цены, неограниченный ассортимент и индивидуальный подход к клиентам являются основой для выстраивания долгосрочного и эффективного сотрудничества с предприятиями радиоэлектронной промышленности, предприятиями ВПК и научно-исследовательскими институтами России.

С нами вы становитесь еще успешнее!

**Наши контакты:**

**Телефон:** +7 812 627 14 35

**Электронная почта:** [sales@st-electron.ru](mailto:sales@st-electron.ru)

**Адрес:** 198099, Санкт-Петербург,  
Промышленная ул, дом № 19, литера Н,  
помещение 100-Н Офис 331