

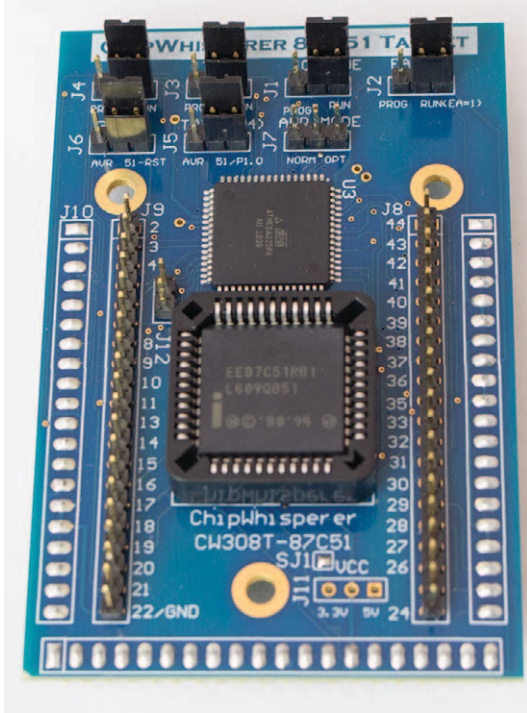

# 87C51 UFO Target



Not everything is about the latest 32-bit ARM processor, this target can be used with a classic Intel 87C51 device. Includes one pre-programmed 87C51 device which does AES Authentication, TEA authentication, password checks, and glitchable code. An AVR “co-processor” provides ability to perform reads on the device to experiment with attacks against the code verification & fuse bits.

Note the included device is OTP so cannot be reused, but you can fit 89C51 PLCC44 devices in the same socket if you wish to have a FLASH based target (will require an external programmer).

The included OTP device has the bonus feature of an “XOR Encryption Table” used during code verification, something not present in the FLASH based devices. This table has been pre-programmed with a known pattern.

**CW308 UFO Baseboard REQUIRED for use!**

## Product Highlights

87C51 in PLCC44 package supported (includes EE87C51RB1).

AVR co-processor provides on-board read support to perform attacks on fuse bits and XOR table.

Provided OTP devices has XOR encryption table enabled (but not fuse bits) to allow attacks on XOR encryption table.

Example application for 87C51 device allows you to perform AES power analysis, XOR power analysis, glitch attacks, and more!

Also works with 89C51 devices (FLASH based), but requires an external programmer to load them (no ISP support).

See wiki documentation for complete tutorial & list of examples!

## Ordering Summary

NAE-CW308T-87C51 UFO Target with 87C51 OTP device (Intel EE87C51RB1).

## Product Links

Full Documentation <https://wiki.newae.com/CW308T-87C51>

# Schematic

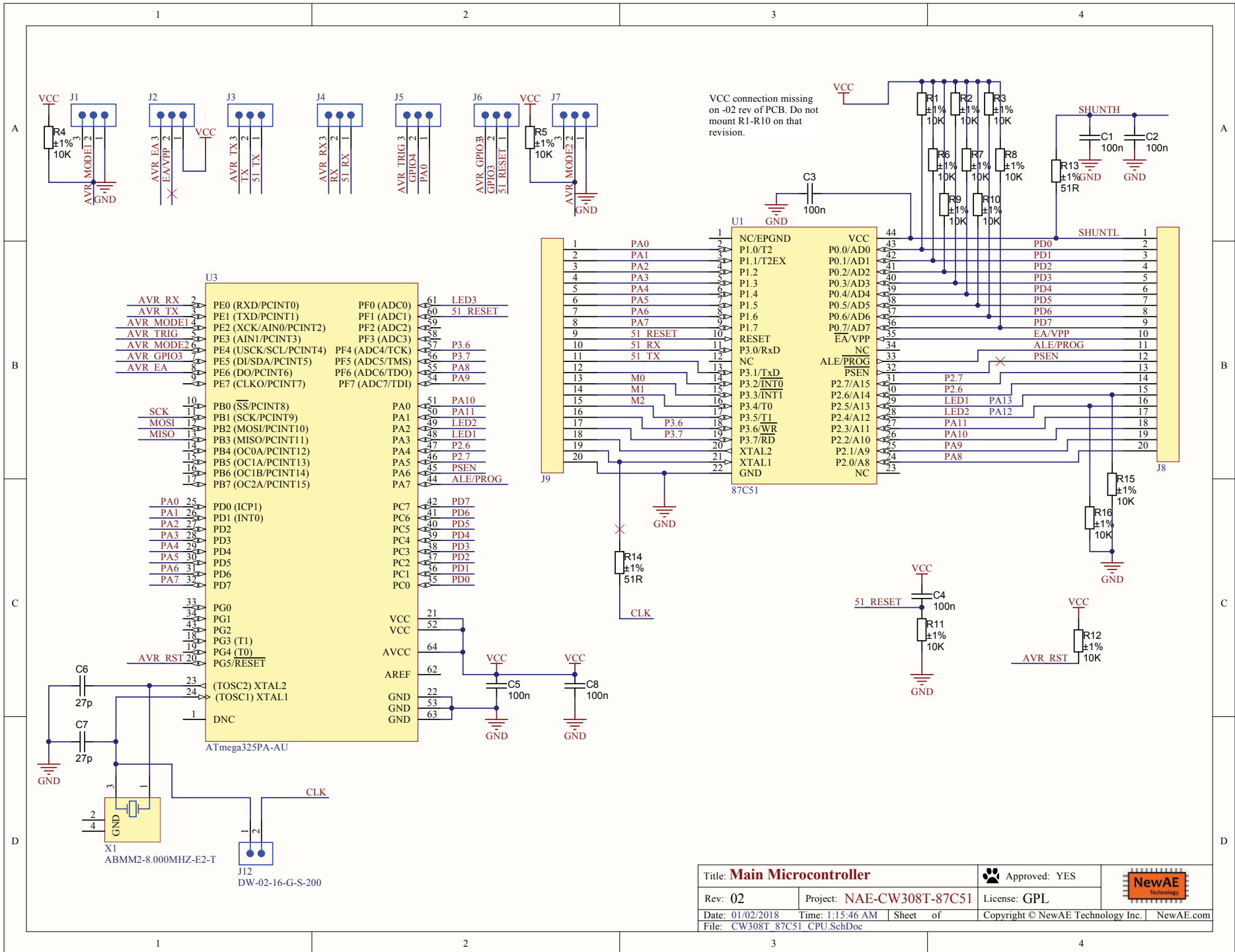

Title: <b>Main Microcontroller</b>		Approved: YES	
Rev: 02	Project: NAE-CW308T-87C51	License: GPL	
Date: 01/02/2018	Time: 1:15:46 AM	Sheet of	
File: CW308T_87C51_CPU.SchDoc		Copyright © NewAE Technology Inc.	NewAE.com

# Schematic

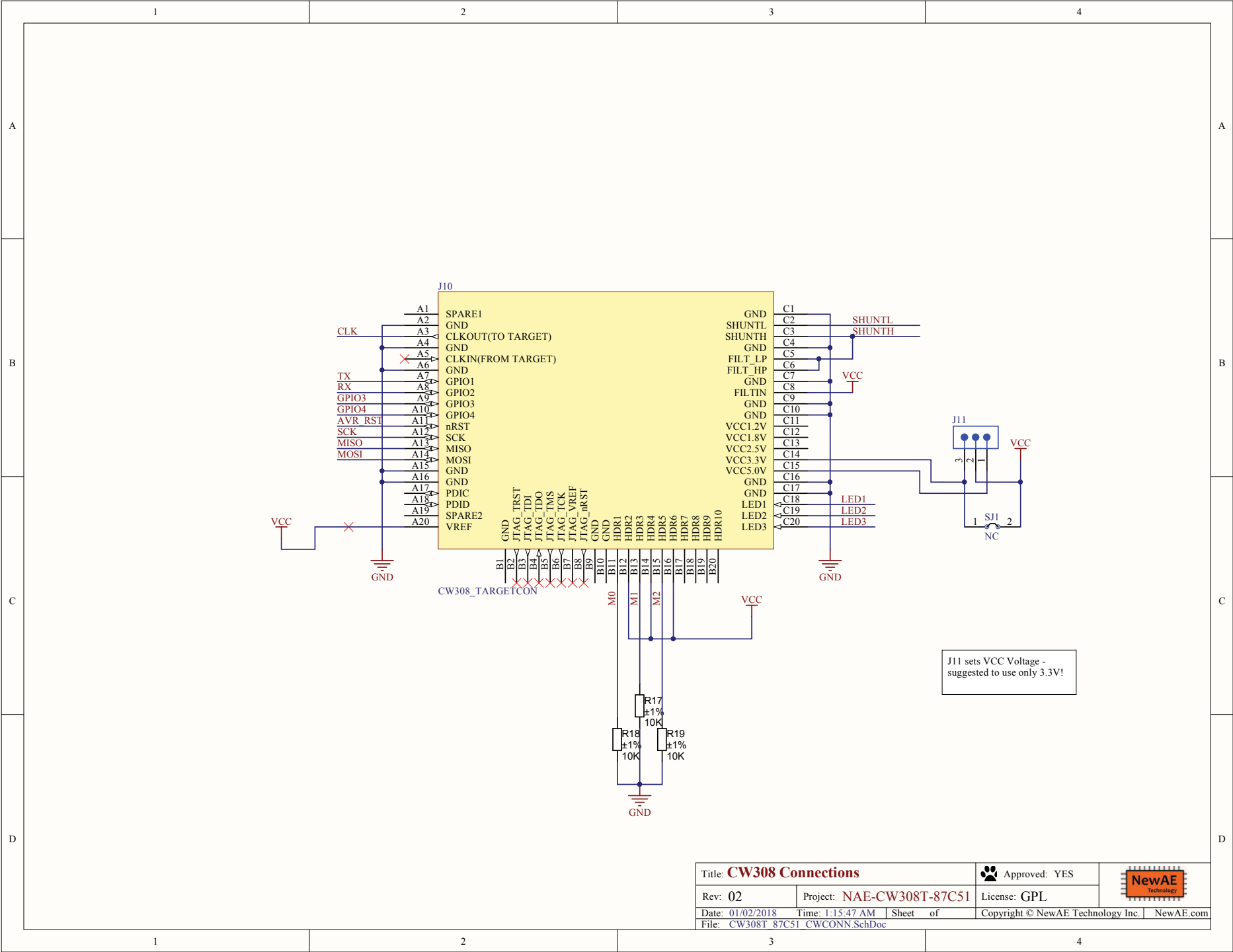

Title: <b>CW308 Connections</b>		Approved: YES	
Rev: 02	Project: NAE-CW308T-87C51	License: GPL	
Date: 01/02/2018	Time: 1:15:47 AM	Sheet of	Copyright © NewAE Technology Inc.   NewAE.com
File: CW308T_87C51_CWCONN.SchDoc			

## Disclaimers

All content is Copyright NewAE Technology Inc., 2018. ChipWhisperer is a trademark of NewAE Technology Inc., registered in the United States of America and Europe. ChipSHOUTER is a trademark of NewAE Technology Inc., registered in Europe. Trademarks are claimed in all jurisdictions and may be registered in other states than specified here.

NewAE Technology makes no representations or warranties with respect to the accuracy or completeness of the contents of this document and reserves the right to make changes to specifications and product descriptions at any time without notice. NewAE Technology does not make any commitment to update the information contained herein. NewAE Technology products are not intended, authorized, or warranted for use as components in applications intended to support or sustain life. NewAE Technology products are designed solely for teaching purposes.

All other product names and trademarks are the property of their respective owners, which are in no way associated or affiliated with NewAE Technology Inc. Use of these names does not imply any co-operation or endorsement.

AVR and XMEGA are registered trademarks or trademarks of Atmel Corporation or its subsidiaries, in the US and/or other countries.

Artix and Spartan are registered trademarks or trademarks of Xilinx, Inc. or its subsidiaries, in the US and/or other countries.

Arm is a registered trademark of Arm Limited (or its subsidiaries) in the US and/or elsewhere.



## Стандарт Электрон Связь

Мы молодая и активно развивающаяся компания в области поставок электронных компонентов. Мы поставляем электронные компоненты отечественного и импортного производства напрямую от производителей и с крупнейших складов мира.

Благодаря сотрудничеству с мировыми поставщиками мы осуществляем комплексные и плановые поставки широчайшего спектра электронных компонентов.

Собственная эффективная логистика и склад в обеспечивает надежную поставку продукции в точно указанные сроки по всей России.

Мы осуществляем техническую поддержку нашим клиентам и предпродажную проверку качества продукции. На все поставляемые продукты мы предоставляем гарантию .

Осуществляем поставки продукции под контролем ВП МО РФ на предприятия военно-промышленного комплекса России , а также работаем в рамках 275 ФЗ с открытием отдельных счетов в уполномоченном банке. Система менеджмента качества компании соответствует требованиям ГОСТ ISO 9001.

Минимальные сроки поставки, гибкие цены, неограниченный ассортимент и индивидуальный подход к клиентам являются основой для выстраивания долгосрочного и эффективного сотрудничества с предприятиями радиоэлектронной промышленности, предприятиями ВПК и научно-исследовательскими институтами России.

С нами вы становитесь еще успешнее!

### Наши контакты:

**Телефон:** +7 812 627 14 35

**Электронная почта:** [sales@st-electron.ru](mailto:sales@st-electron.ru)

**Адрес:** 198099, Санкт-Петербург,  
Промышленная ул, дом № 19, литера Н,  
помещение 100-Н Офис 331