



FAST CMOS 16-BIT LATCHED TRANSCEIVER

IDT74FCT16543AT/CT

FEATURES:

- 0.5 MICRON CMOS Technology
- High-speed, low-power CMOS replacement for ABT functions
- Typical $t_{sk(o)}$ (Output Skew) < 250ps
- Low input and output leakage $\leq 1\mu A$ (max.)
- $V_{CC} = 5V \pm 10\%$
- High drive outputs (-32mA IOH, 64mA IOL)
- Power off disable outputs permit "live insertion"
- Typical V_{OLP} (Output Ground Bounce) < 1.0V at $V_{CC} = 5V$, $T_A = 25^\circ C$
- Available in SSOP and TSSOP packages

DESCRIPTION:

The FCT16543T 16-bit latched transceivers are built using advanced dual metal CMOS technology. These high-speed, low-power devices are organized as two independent 8-bit D-type latched transceivers with separate input and output control to permit independent control of data flow in either direction. For example, the A-to-B Enable (\overline{xCEAB}) must be low in order to enter data from the A port or to output data from the B port. \overline{xLEAB} controls the latch function. When \overline{xLEAB} is low, the latches are transparent. A subsequent low-to-high transition of \overline{xLEAB} signal puts the A latches in the storage mode. \overline{xOEAB} performs output enable function on the B port. Data flow from the B port to the A port is similar but requires using \overline{xCEBA} , \overline{xLEBA} , and \overline{xOEBA} inputs. Flow-through organization of signal pins simplifies layout. All inputs are designed with hysteresis for improved noise margin.

The FCT16543T is ideally suited for driving high-capacitance loads and low-impedance backplanes. The output buffers are designed with power off disable capability to allow "live insertion" of boards when used as backplane drivers.

FUNCTIONAL BLOCK DIAGRAM



IDT and the IDT logo are registered trademarks of Integrated Device Technology, Inc.

INDUSTRIAL TEMPERATURE RANGE

JULY 2017

PIN CONFIGURATION



TOP VIEW

Package Type	Package Code	Order Code
TSSOP	PAG56	PAG
SSOP	PVG56	PVG

PIN DESCRIPTION

Pin Names	Description
\overline{xOEAB}	A-to-B Output Enable Input (Active LOW)
$\overline{xOEB\overline{A}}$	B-to-A Output Enable Input (Active LOW)
\overline{xCEAB}	A-to-B Enable Input (Active LOW)
\overline{xCEBA}	B-to-A Enable Input (Active LOW)
\overline{xLEAB}	A-to-B Latch Enable Input (Active LOW)
\overline{xLEBA}	B-to-A Latch Enable Input (Active LOW)
\overline{xAx}	A-to-B Data Inputs or B-to-A 3-State Outputs
\overline{xBx}	B-to-A Data Inputs or A-to-B 3-State Outputs

ABSOLUTE MAXIMUM RATINGS⁽¹⁾

Symbol	Description	Max	Unit
$V_{TERM}^{(2)}$	Terminal Voltage with Respect to GND	-0.5 to 7	V
$V_{TERM}^{(3)}$	Terminal Voltage with Respect to GND	-0.5 to $V_{CC}+0.5$	V
TSTG	Storage Temperature	-65 to +150	°C
IOUT	DC Output Current	-60 to +120	mA

NOTES:

- Stresses greater than those listed under ABSOLUTE MAXIMUM RATINGS may cause permanent damage to the device. This is a stress rating only and functional operation of the device at these or any other conditions above those indicated in the operational sections of this specification is not implied. Exposure to absolute maximum rating conditions for extended periods may affect reliability.
- All device terminals except FCT162XXX Output and I/O terminals.
- Outputs and I/O terminals for FCT162XXX.

CAPACITANCE ($T_A = +25^\circ\text{C}$, $f = 1.0\text{MHz}$)

Symbol	Parameter ⁽¹⁾	Conditions	Typ.	Max.	Unit
CIN	Input Capacitance	$V_{IN} = 0V$	3.5	6	pF
COU	Output Capacitance	$V_{OUT} = 0V$	3.5	8	pF

NOTE:

- This parameter is measured at characterization but not tested.

FUNCTION TABLE^(1, 2)

For A-to-B (Symmetric with B-to-A)

Inputs			Latch Status	Output Buffers
\overline{xCEAB}	\overline{xLEAB}	$\overline{xOEB\overline{A}}$	\overline{xAx} to \overline{xBx}	\overline{xBx}
H	X	X	Storing	Z
X	H	X	Storing	X
L	L	L	Transparent	Current A Inputs
L	H	L	Storing	Previous* A Inputs
L	L	H	Transparent	Z
L	H	H	Storing	Z

NOTES:

- * Before \overline{xLEAB} LOW-to-HIGH Transition
H = HIGH Voltage Level
L = LOW Voltage Level
X = Don't Care
- A-to-B data flow shown; B-to-A flow control is the same, except using \overline{xCEBA} , \overline{xLEBA} and \overline{xOEBA} .

DC ELECTRICAL CHARACTERISTICS OVER OPERATING RANGE

Following Conditions Apply Unless Otherwise Specified:

Industrial: $T_A = -40^{\circ}\text{C}$ to $+85^{\circ}\text{C}$, $V_{CC} = 5.0\text{V} \pm 10\%$

Symbol	Parameter	Test Conditions ⁽¹⁾		Min.	Typ. ⁽²⁾	Max.	Unit
V_{IH}	Input HIGH Level	Guaranteed Logic HIGH Level		2	—	—	V
V_{IL}	Input LOW Level	Guaranteed Logic LOW Level		—	—	0.8	V
I_{IH}	Input HIGH Current (Input pins) ⁽⁵⁾	$V_{CC} = \text{Max.}$	$V_i = V_{CC}$	—	—	± 1	μA
	Input HIGH Current (I/O pins) ⁽⁵⁾			—	—	± 1	
I_{IL}	Input LOW Current (Input pins) ⁽⁵⁾		$V_i = \text{GND}$	—	—	± 1	
	Input LOW Current (I/O pins) ⁽⁵⁾			—	—	± 1	
I_{OZH}	High Impedance Output Current (3-State Output pins) ⁽⁵⁾	$V_{CC} = \text{Max.}$	$V_o = 2.7\text{V}$	—	—	± 1	μA
I_{OZL}			$V_o = 0.5\text{V}$	—	—	± 1	
V_{IK}	Clamp Diode Voltage	$V_{CC} = \text{Min.}, I_{IN} = -18\text{mA}$		—	-0.7	-1.2	V
I_{OS}	Short Circuit Current	$V_{CC} = \text{Max.}, V_o = \text{GND}^{(3)}$		-80	-140	-250	mA
V_H	Input Hysteresis	—		—	100	—	mV
I_{CCL}	Quiescent Power Supply Current	$V_{CC} = \text{Max}$		—	5	500	μA
I_{CCH}		$V_{IN} = \text{GND or } V_{CC}$					
I_{CCZ}							

OUTPUT DRIVE CHARACTERISTICS

Symbol	Parameter	Test Conditions ⁽¹⁾		Min.	Typ. ⁽²⁾	Max.	Unit
I_o	Output Drive Current	$V_{CC} = \text{Max.}, V_o = 2.5\text{V}^{(3)}$		-50	—	-180	mA
V_{OH}	Output HIGH Voltage	$V_{CC} = \text{Min.}$ $V_{IN} = V_{IH} \text{ or } V_{IL}$	$I_{OH} = -3\text{mA}$	2.5	3.5	—	V
			$I_{OH} = -15\text{mA}$	2.4	3.5	—	V
			$I_{OH} = -32\text{mA}^{(4)}$	2	3	—	V
V_{OL}	Output LOW Voltage	$V_{CC} = \text{Min.}$ $V_{IN} = V_{IH} \text{ or } V_{IL}$	$I_{OL} = 64\text{mA}$	—	0.2	0.55	V
I_{OFF}	Input/Output Power Off Leakage ⁽⁵⁾	$V_{CC} = 0\text{V}, V_{IN} = \text{ or } V_o \leq 4.5\text{V}$		—	—	± 1	μA

NOTES:

1. For conditions shown as Min. or Max., use appropriate value specified under Electrical Characteristics for the applicable device type.
2. Typical values are at $V_{CC} = 5.0\text{V}$, $+25^{\circ}\text{C}$ ambient.
3. Not more than one output should be shorted at one time. Duration of the test should not exceed one second.
4. Duration of the condition can not exceed one second.
5. This test limit for this parameter is $\pm 5\mu\text{A}$ at $T_A = -55^{\circ}\text{C}$.

POWER SUPPLY CHARACTERISTICS

Symbol	Parameter	Test Conditions ⁽¹⁾		Min.	Typ. ⁽²⁾	Max.	Unit
ΔI_{CC}	Quiescent Power Supply Current TTL Inputs HIGH	$V_{CC} = \text{Max.}$ $V_{IN} = 3.4V^{(3)}$		—	0.5	1.5	mA
I_{CCD}	Dynamic Power Supply Current ⁽⁴⁾	$V_{CC} = \text{Max.}$, Outputs Open \overline{xCEAB} and $\overline{xOEAB} = \text{GND}$ $\overline{xCEBA} = V_{CC}$ One Input Toggling 50% Duty Cycle	$V_{IN} = V_{CC}$ $V_{IN} = \text{GND}$	—	60	100	$\mu\text{A}/\text{MHz}$
I_C	Total Power Supply Current ⁽⁶⁾	$V_{CC} = \text{Max.}$, Outputs Open $f_i = 10\text{MHz}$ 50% Duty Cycle \overline{xLEAB} , \overline{xCEAB} and $\overline{xOEAB} = \text{GND}$ $\overline{xCEBA} = V_{CC}$ One Bit Toggling	$V_{IN} = V_{CC}$ $V_{IN} = \text{GND}$	—	0.6	1.5	mA
			$V_{IN} = 3.4V$ $V_{IN} = \text{GND}$	—	0.9	2.3	
		$V_{CC} = \text{Max.}$, Outputs Open $f_i = 2.5\text{MHz}$ 50% Duty Cycle \overline{xLEAB} , \overline{xCEAB} and $\overline{xOEAB} = \text{GND}$ $\overline{xCEBA} = V_{CC}$ Sixteen Bits Toggling	$V_{IN} = V_{CC}$ $V_{IN} = \text{GND}$	—	2.4	4.5 ⁽⁵⁾	
			$V_{IN} = 3.4V$ $V_{IN} = \text{GND}$	—	6.4	16.5 ⁽⁵⁾	

NOTES:

- For conditions shown as Max. or Min., use appropriate value specified under Electrical Characteristics for the applicable device type.
- Typical values are at $V_{CC} = 5.0V$, $+25^\circ\text{C}$ ambient.
- Per TTL driven input ($V_{IN} = 3.4V$). All other inputs at V_{CC} or GND.
- This parameter is not directly testable, but is derived for use in Total Power Supply Calculations.
- Values for these conditions are examples of the I_{CC} formula. These limits are guaranteed but not tested.
- $I_C = I_{QUIESCENT} + I_{INPUTS} + I_{DYNAMIC}$
 $I_C = I_{CC} + \Delta I_{CC} D_H N_T + I_{CCD} (f_{CP} N_{CP} / 2 + f_i N_i)$
 $I_{CC} = \text{Quiescent Current (} I_{CCL}, I_{CCH} \text{ and } I_{CCZ} \text{)}$
 $\Delta I_{CC} = \text{Power Supply Current for a TTL High Input (} V_{IN} = 3.4V \text{)}$
 $D_H = \text{Duty Cycle for TTL Inputs High}$
 $N_T = \text{Number of TTL Inputs at } D_H$
 $I_{CCD} = \text{Dynamic Current Caused by an Input Transition Pair (HLH or LHL)}$
 $f_{CP} = \text{Clock Frequency for Register Devices (Zero for Non-Register Devices)}$
 $N_{CP} = \text{Number of Clock Inputs at } f_{CP}$
 $f_i = \text{Input Frequency}$
 $N_i = \text{Number of Inputs at } f_i$

SWITCHING CHARACTERISTICS OVER OPERATING RANGE

Symbol	Parameter	Condition ⁽²⁾	74FCT16543AT		74FCT16543CT		Unit
			Min. ⁽²⁾	Max.	Min. ⁽²⁾	Max.	
t _{PLH} t _{PHL}	Propagation Delay Transparent Mode xAx to xBx or xBx to xAx	C _L = 50pF R _L = 500Ω	1.5	6.5	1.5	5.1	ns
t _{PLH} t _{PHL}	Propagation Delay xLEBA to xAx, xLEAB to xBx		1.5	8	1.5	5.6	ns
t _{PHZ} t _{PLZ}	Output Enable Time xOEBA or xOEAB to xAx or xBx xCEBA or xCEAB to xAx or xBx		1.5	9	1.5	7.8	ns
t _{PZH} t _{PZL}	Output Disable Time xOEBA or xOEAB to xAx or xBx xCEBA or xCEAB to xAx or xBx		1.5	7.5	1.5	6.5	ns
t _{SU}	Set-up Time HIGH or LOW xAx or xBx to xLEAB or xLEBA		2	—	2	—	ns
t _H	Hold Time HIGH or LOW xAx or xBx to xLEAB or xLEBA		2	—	2	—	ns
t _w	xLEAB or xLEBA Pulse Width LOW		4	—	4	—	ns
t _{SK(o)}	Output Skew ⁽³⁾		—	0.5	—	0.5	ns

NOTES:

1. See test circuit and waveforms.
2. Minimum limits are guaranteed but not tested.
3. Skew between any two outputs, of the same package, switching in the same direction. This parameter is guaranteed by design.

TEST CIRCUITS AND WAVEFORMS

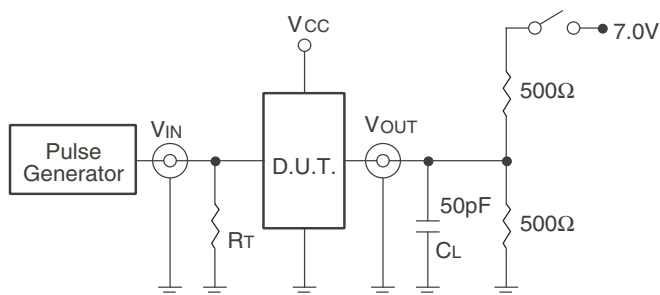

Test Circuits for All Outputs



Set-up, Hold, and Release Times



Propagation Delay

SWITCH POSITION

Test	Switch
Open Drain Disable Low Enable Low	Closed
All Other Tests	Open

DEFINITIONS:

CL = Load capacitance: includes jig and probe capacitance.
RT = Termination resistance: should be equal to Zout of the Pulse Generator.



Pulse Width

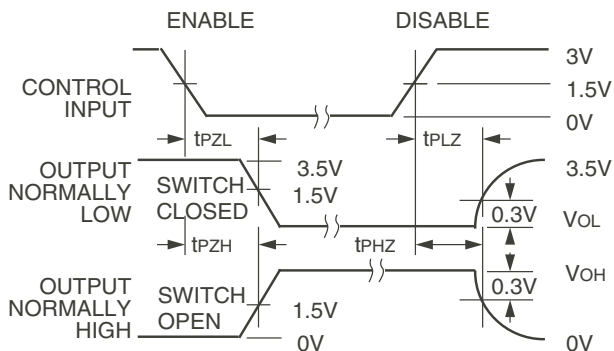

Enable and Disable Times

NOTES:

1. Diagram shown for input Control Enable-LOW and input Control Disable-HIGH.
2. Pulse Generator for All Pulses: Rate $\leq 1.0\text{MHz}$; $t_r \leq 2.5\text{ns}$; $t_f \leq 2.5\text{ns}$.

ORDERING INFORMATION



Orderable Part Information

Speed (ns)	Orderable Part ID	Pkg. Code	Pkg. Type	Temp. Grade
A	74FCT16543ATPAG	PAG56	TSSOP	I
	74FCT16543ATPAG8	PAG56	TSSOP	I
	74FCT16543ATPVG	PVG56	SSOP	I
	74FCT16543ATPVG8	PVG56	SSOP	I
C	74FCT16543CTPAG	PAG56	TSSOP	I
	74FCT16543CTPAG8	PAG56	TSSOP	I
	74FCT16543CTPVG	PVG56	SSOP	I
	74FCT16543CTPVG8	PVG56	SSOP	I

Datasheet Document History

09/28/2009	Pg. 7	Updated the ordering information by removing the "IDT" notation and non RoHS part.
07/31/2017	Pg. 1, 2, 5, 7	Added table under pin configuration diagram with detailed package information. Updated the ordering information diagram by deleting 543ET, TSSOP package and adding Tube, Tape and Reel. Added orderable part information table.



CORPORATE HEADQUARTERS
6024 Silver Creek Valley Road
San Jose, CA 95138

for SALES:
800-345-7015 or 408-284-8200
fax: 408-284-2775
www.idt.com

for Tech Support:
logichelp@idt.com



Стандарт Электрон Связь

Мы молодая и активно развивающаяся компания в области поставок электронных компонентов. Мы поставляем электронные компоненты отечественного и импортного производства напрямую от производителей и с крупнейших складов мира.

Благодаря сотрудничеству с мировыми поставщиками мы осуществляем комплексные и плановые поставки широчайшего спектра электронных компонентов.

Собственная эффективная логистика и склад в обеспечивает надежную поставку продукции в точно указанные сроки по всей России.

Мы осуществляем техническую поддержку нашим клиентам и предпродажную проверку качества продукции. На все поставляемые продукты мы предоставляем гарантию .

Осуществляем поставки продукции под контролем ВП МО РФ на предприятия военно-промышленного комплекса России , а также работаем в рамках 275 ФЗ с открытием отдельных счетов в уполномоченном банке. Система менеджмента качества компании соответствует требованиям ГОСТ ISO 9001.

Минимальные сроки поставки, гибкие цены, неограниченный ассортимент и индивидуальный подход к клиентам являются основой для выстраивания долгосрочного и эффективного сотрудничества с предприятиями радиоэлектронной промышленности, предприятиями ВПК и научно-исследовательскими институтами России.

С нами вы становитесь еще успешнее!

Наши контакты:

Телефон: +7 812 627 14 35

Электронная почта: sales@st-electron.ru

Адрес: 198099, Санкт-Петербург,
Промышленная ул, дом № 19, литера Н,
помещение 100-Н Офис 331