

MC10SX1189

Fibre Channel Coaxial Cable Driver and Loop Resiliency Circuit



ON Semiconductor®

<http://onsemi.com>

FIBRE CHANNEL COAXIAL CABLE DRIVER AND LOOP RESILIENCY CIRCUIT

Description

The MC10SX1189 is a differential receiver, differential transmitter specifically designed to drive coaxial cables. It incorporates the output cable drive capability of the MC10EL89 Coaxial Cable Driver with additional circuitry to multiplex the output cable drive source between the cable receiver or the local transmitter inputs. The multiplexer control circuitry is TTL compatible for ease of operation.

The MC10SX1189 is useful as a bypass element for Fibre Channel-Arbitrated Loop (FC-AL) or Serial Storage Architecture (SSA) applications, to create loop style interconnects with fault tolerant, active switches at each device node. This device is particularly useful for back panel applications where small size is desirable.

The EL89 style drive circuitry produces swings twice as large as a standard PECL output. When driving a coaxial cable, proper termination is required at both ends of the line to minimize reflections. The 1.6 V output swings allow for proper termination at both ends of the cable, while maintaining the required swing at the receiving end of the cable. Because of the larger output swings, the QT, \overline{QT} outputs are terminated into the thevenin equivalent of 50 Ω to $V_{CC} - 3.0$ V instead of 50 Ω to $V_{CC} - 2.0$ V.

Features

- 425 ps Propagation Delay
- 1.6 V Output Swing on the Cable Driving Output
- Operation Range: $V_{CC} = 4.5$ V to 5.5 V
- 75 k Ω Internal Input Pull Down Resistors
- >1000 V ESD Protection
- Transistor Count = 102
- Pb-Free Packages are Available*

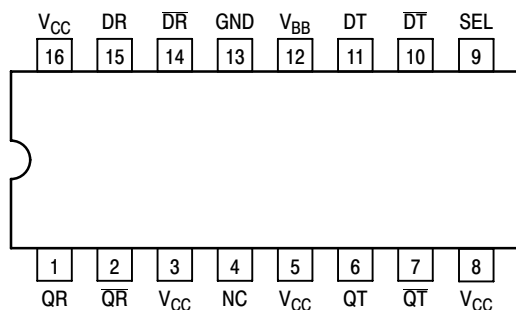
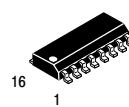

Figure 1. Pinout: 16-Lead SOIC (Top View)

*For additional information on our Pb-Free strategy and soldering details, please download the ON Semiconductor Soldering and Mounting Techniques Reference Manual, SOLDERRM/D.



SOIC
CASE 751B

10SX1189 = Specific Device Code
A = Assembly Location
WL = Wafer Lot
Y = Year
WW = Work Week
G = Pb-Free Package

TRUTH TABLE

SEL	Function
L	DR → QT
H	DT → QT

PIN NAMES

Pins	Function
DR/ \overline{DR} QR/ \overline{QR}	Differential Input from Receive Cable Buffered Differential Output from Receive Cable
DT/ \overline{DT} QT/ \overline{QT}	Differential Input to Transmit Cable Buffered Differential Output to Transmit Cable
SEL	Multiplexer Control Signal (TTL)
V_{CC}	Positive Power Supply
GND	Ground
V_{BB}	Reference Voltage Output

ORDERING INFORMATION

See detailed ordering and shipping information in the package dimensions section on page 4 of this data sheet.

MC10SX1189

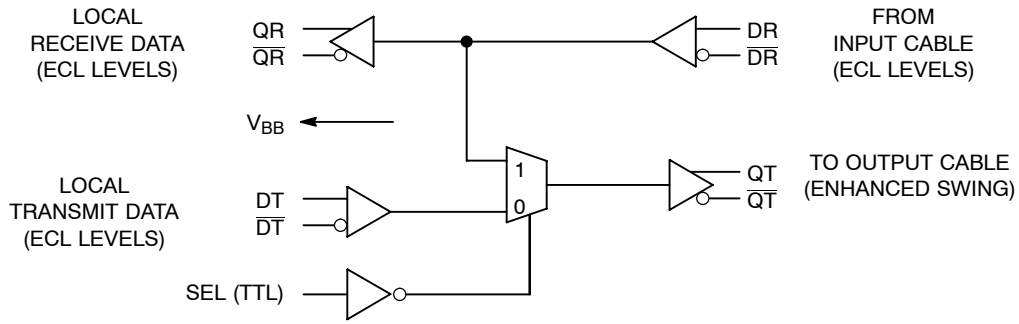

Figure 2. LOGIC DIAGRAM

Table 1. ABSOLUTE MAXIMUM RATINGS

Symbol	Parameter	Value	Unit	
V _{CC}	Power Supply Voltage (Referenced to GND)	0 to +7.0	Vdc	
V _{IN}	Input Voltage (Referenced to GND)	0 to +6.0	Vdc	
I _{OUT}	Output Current	Continuous Surge	50 100	mA
T _A	Operating Temperature Range	-40 to +85	°C	
T _{STG}	Storage Temperature Range	-50 to +150	°C	

Maximum ratings are those values beyond which device damage can occur. Maximum ratings applied to the device are individual stress limit values (not normal operating conditions) and are not valid simultaneously. If these limits are exceeded, device functional operation is not implied, damage may occur and reliability may be affected.

MC10SX1189

Table 2. DC CHARACTERISTICS ($V_{CC} = 5.0\text{ V}$, $V_{EE} = 0\text{ V}$)

Symbol	Characteristic	-40°C			25°C			85°C			Unit
		Min	Typ	Max	Min	Typ	Max	Min	Typ	Max	
V_{OH}	Output Voltage High (QR, \overline{QR}) $V_{CC} = 5.0\text{ V}$, GND = 0 V (Notes 1, 2)	3.92	4.05	4.22	3.97	4.11	4.27	4.00	4.16	4.30	V
V_{OL}	Output Voltage Low (QR, \overline{QR}) $V_{CC} = 5.0\text{ V}$, GND = 0 V (Notes 1, 2)	3.05	3.23	3.35	3.07	3.24	3.37	3.10	3.25	3.41	V
V_{OH}	Output Voltage High (QT, \overline{QT}) $V_{CC} = 5.0\text{ V}$, GND = 0 V (Notes 1, 3)	3.83	3.95	4.10	3.88	4.02	4.15	3.90	4.09	4.17	V
V_{OL}	Output Voltage Low (QT, \overline{QT}) $V_{CC} = 5.0\text{ V}$, GND = 0 V (Notes 1, 3)	1.90	2.33	2.50	1.85	2.26	2.45	1.85	2.23	2.45	V
I_{CC}	Quiescent Supply Current (Note 4)	20	25	42	23	27	47	25	28	47	mA
V_{IH}	Input Voltage High (DR, \overline{DR} & DT, \overline{DT}) $V_{CC} = 5.0\text{ V}$, GND = 0 V (Note 1)	3.77		4.11	3.87		4.19	3.94		4.28	V
V_{IL}	Input Voltage Low (DR, \overline{DR} & DT, \overline{DT}) $V_{CC} = 5.0\text{ V}$, GND = 0 V (Note 1)	3.05		3.50	3.05		3.52	3.05		3.56	V
V_{IH}	Input Voltage High SEL	2.0			2.0			2.0			V
V_{IL}	Input Voltage Low SEL			0.8			0.8			0.8	V
V_{BB}	Output Reference Voltage $V_{CC} = 5.0\text{ V}$, GND = 0 V (Note 1)	3.57	3.63	3.70	3.65	3.70	3.75	3.69	3.75	3.81	V
I_{IH}	Input HIGH Current			150			150			150	μA
I_{IL}	Input LOW Current	0.5			0.5			0.5			μA

NOTE: Device will meet the specifications after thermal equilibrium has been established when mounted in a test socket or printed circuit board with maintained transverse airflow greater than 500 lfpm. Electrical parameters are guaranteed only over the declared operating temperature range. Functional operation of the device exceeding these conditions is not implied. Device specification limit values are applied individually under normal operating conditions and not valid simultaneously.

1. Values will track 1:1 with the V_{CC} supply. V_{EE} can vary +0.5 V to -0.5 V.
2. Outputs loaded with 50 Ω to $V_{CC} - 2.0\text{ V}$.
3. Outputs loaded with 50 Ω to $V_{CC} - 3.0\text{ V}$.
4. Outputs open circuited.

MC10SX1189

Table 3. AC CHARACTERISTICS ($V_{CC} = 4.5\text{ V to }5.5\text{ V}$) (Note 5)

Symbol	Characteristic	-40°C			0 to 85°C			Unit	Condition	
		Min	Typ	Max	Min	Typ	Max			
t_{PLH} , t_{PHL}	Propagation Delay to Output	DR → QR (Diff) (SE)	175	300	450	225	325	500	ps	Note 6 Note 7
			150	300	500	175	325	550		
DR → QT (Diff) (SE)		250	425	650	300	450	650			
		225	425	700	250	450	700			
DT → QT (Diff) (SE)	225	400	650	275	425	650				
	200	400	725	225	425	725				
	Propagation Delay	SEL → QT, \overline{QT}	450	600	850	500	650	800		1.5V to 50% Pt
t_r , t_f	Rise Time	QR, \overline{QR}	100	275	400	125	275	400	ps	20% to 80% 80% to 20%
	Fall Time		100	275	400	125	275	400		
t_r , t_f	Rise Time	QT, \overline{QT}	150	300	550	150	300	550	ps	20% to 80% 80% to 20%
	Fall Time		150	300	550	150	300	550		
t_{skew}	Within Device Skew			15			15		ps	Note 8
V_{PP}	Minimum Input Swing		200		1000	200		1000	mV	Note 9
V_{CMR}	Common Mode Range		3.00		4.35	3.00		4.35	V	Note 10

NOTE: Device will meet the specifications after thermal equilibrium has been established when mounted in a test socket or printed circuit board with maintained transverse airflow greater than 500 lfm. Electrical parameters are guaranteed only over the declared operating temperature range. Functional operation of the device exceeding these conditions is not implied. Device specification limit values are applied individually under normal operating conditions and not valid simultaneously.

5. V_{EE} can vary +0.5 V to -0.5 V.
6. The differential propagation delay is defined as the delay from the crossing points of the differential input signals to the crossing point of the differential output signals.
7. The single-ended propagation delay is defined as the delay from the 50% point of the input signal to the 50% point of the output signal.
8. Duty cycle skew is the difference between t_{PLH} and t_{PHL} propagation delay through a device.
9. Minimum input swing for which AC parameters are guaranteed.
10. The CMR range is referenced to the most positive side of the differential input signal. Normal operation is obtained if the HIGH level falls within the specified range and the peak-to-peak voltage lies between $V_{PP\text{ Min}}$ and 1.0 V.

ORDERING INFORMATION

Device	Package	Shipping [†]
MC10SX1189D	SOIC-16	45 Units / Rail
MC10SX1189DG	SOIC-16 (Pb-Free)	45 Units / Rail
MC10SX1189DR2	SOIC-16	2500 / Tape & Reel
MC10SX1189DR2G	SOIC-16 (Pb-Free)	2500 / Tape & Reel

[†]For information on tape and reel specifications, including part orientation and tape sizes, please refer to our Tape and Reel Packaging Specifications Brochure, BRD8011/D.

MC10SX1189

PACKAGE DIMENSIONS

SOIC
CASE 751B-05
ISSUE J

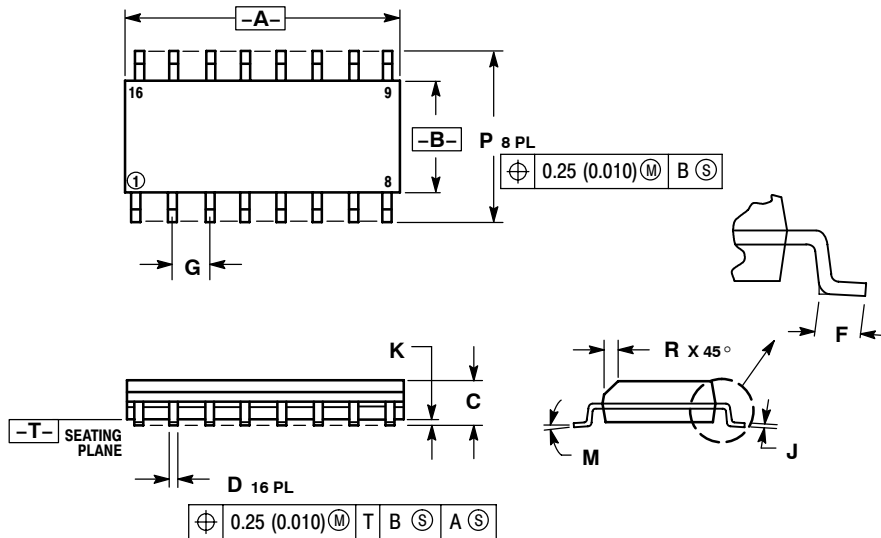

NOTES:

1. DIMENSIONING AND TOLERANCING PER ANSI Y14.5M, 1982.
2. CONTROLLING DIMENSION: MILLIMETER.
3. DIMENSIONS A AND B DO NOT INCLUDE MOLD PROTRUSION.
4. MAXIMUM MOLD PROTRUSION 0.15 (0.006) PER SIDE.
5. DIMENSION D DOES NOT INCLUDE DAMBAR PROTRUSION. ALLOWABLE DAMBAR PROTRUSION SHALL BE 0.127 (0.005) TOTAL IN EXCESS OF THE D DIMENSION AT MAXIMUM MATERIAL CONDITION.

DIM	MILLIMETERS		INCHES	
	MIN	MAX	MIN	MAX
A	9.80	10.00	0.386	0.393
B	3.80	4.00	0.150	0.157
C	1.35	1.75	0.054	0.068
D	0.35	0.49	0.014	0.019
F	0.40	1.25	0.016	0.049
G	1.27 BSC		0.050 BSC	
J	0.19	0.25	0.008	0.009
K	0.10	0.25	0.004	0.009
M	0°	7°	0°	7°
P	5.80	6.20	0.229	0.244
R	0.25	0.50	0.010	0.019

ON Semiconductor and are registered trademarks of Semiconductor Components Industries, LLC (SCILLC). SCILLC reserves the right to make changes without further notice to any products herein. SCILLC makes no warranty, representation or guarantee regarding the suitability of its products for any particular purpose, nor does SCILLC assume any liability arising out of the application or use of any product or circuit, and specifically disclaims any and all liability, including without limitation special, consequential or incidental damages. "Typical" parameters which may be provided in SCILLC data sheets and/or specifications can and do vary in different applications and actual performance may vary over time. All operating parameters, including "Typicals" must be validated for each customer application by customer's technical experts. SCILLC does not convey any license under its patent rights nor the rights of others. SCILLC products are not designed, intended, or authorized for use as components in systems intended for surgical implant into the body, or other applications intended to support or sustain life, or for any other application in which the failure of the SCILLC product could create a situation where personal injury or death may occur. Should Buyer purchase or use SCILLC products for any such unintended or unauthorized application, Buyer shall indemnify and hold SCILLC and its officers, employees, subsidiaries, affiliates, and distributors harmless against all claims, costs, damages, and expenses, and reasonable attorney fees arising out of, directly or indirectly, any claim of personal injury or death associated with such unintended or unauthorized use, even if such claim alleges that SCILLC was negligent regarding the design or manufacture of the part. SCILLC is an Equal Opportunity/Affirmative Action Employer. This literature is subject to all applicable copyright laws and is not for resale in any manner.

PUBLICATION ORDERING INFORMATION

LITERATURE FULFILLMENT:
Literature Distribution Center for ON Semiconductor
P.O. Box 61312, Phoenix, Arizona 85082-1312 USA
Phone: 480-829-7710 or 800-344-3860 Toll Free USA/Canada
Fax: 480-829-7709 or 800-344-3867 Toll Free USA/Canada
Email: orderlit@onsemi.com

N. American Technical Support: 800-282-9855 Toll Free
USA/Canada

Japan: ON Semiconductor, Japan Customer Focus Center
2-9-1 Kamimeguro, Meguro-ku, Tokyo, Japan 153-0051
Phone: 81-3-5773-3850

ON Semiconductor Website: <http://onsemi.com>

Order Literature: <http://www.onsemi.com/litorder>

For additional information, please contact your local Sales Representative.



Стандарт Электрон Связь

Мы молодая и активно развивающаяся компания в области поставок электронных компонентов. Мы поставляем электронные компоненты отечественного и импортного производства напрямую от производителей и с крупнейших складов мира.

Благодаря сотрудничеству с мировыми поставщиками мы осуществляем комплексные и плановые поставки широчайшего спектра электронных компонентов.

Собственная эффективная логистика и склад в обеспечивает надежную поставку продукции в точно указанные сроки по всей России.

Мы осуществляем техническую поддержку нашим клиентам и предпродажную проверку качества продукции. На все поставляемые продукты мы предоставляем гарантию .

Осуществляем поставки продукции под контролем ВП МО РФ на предприятия военно-промышленного комплекса России , а также работаем в рамках 275 ФЗ с открытием отдельных счетов в уполномоченном банке. Система менеджмента качества компании соответствует требованиям ГОСТ ISO 9001.

Минимальные сроки поставки, гибкие цены, неограниченный ассортимент и индивидуальный подход к клиентам являются основой для выстраивания долгосрочного и эффективного сотрудничества с предприятиями радиоэлектронной промышленности, предприятиями ВПК и научно-исследовательскими институтами России.

С нами вы становитесь еще успешнее!

Наши контакты:

Телефон: +7 812 627 14 35

Электронная почта: sales@st-electron.ru

Адрес: 198099, Санкт-Петербург,
Промышленная ул, дом № 19, литера Н,
помещение 100-Н Офис 331