

FEATURES

- Demonstrates a complete digitally-controlled microphone preamplifier circuit based on THAT5173 IC
- Controls gain of the 1570, 1580 or 1583 microphone preamplifier.
- Balanced audio input/output on XLR and TRS connectors
- Supports pro audio signal levels: +26 dBu (input and output, $\pm 15V$ supplies)
- Gain adjustable in 3 dB steps from 0 dB to 60 dB
- Easy to use PC Graphical User Interface software
- Generous prototyping area

Description

The THAT 5173-DEMO Digitally-Controlled Mic Preamp Demo Board allows developers to evaluate the THAT5173 digital gain controller IC with any member of the growing family of THAT differential output microphone preamplifiers. A fully-featured

microphone preamplifier is demonstrated with phantom power switching and fault protection, mic/line switching, RFI filtering, and output conditioning. The board is controlled by a user-friendly PC graphical user interface over USB.

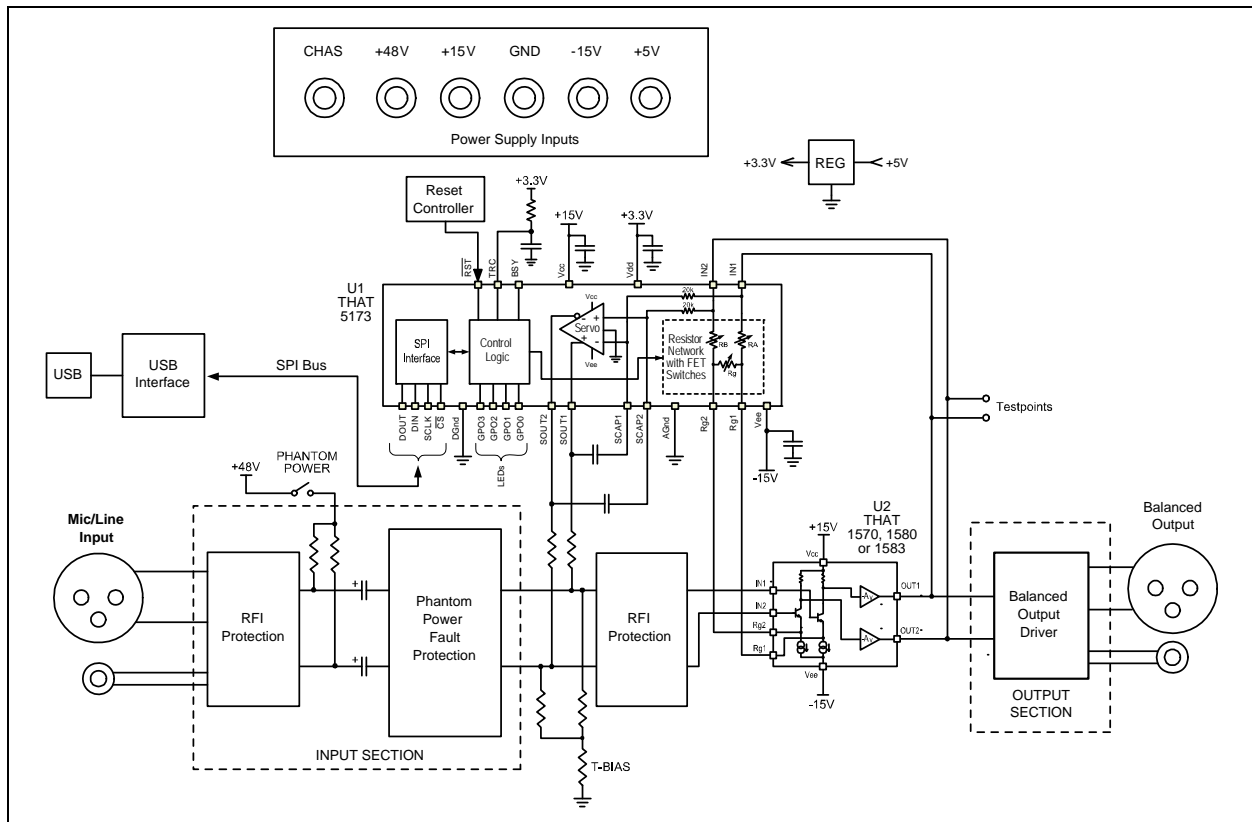

Figure 1. Block Diagram of the THAT 5173 Demo Board

Overview

The THAT5173 is a digital gain controller for low-noise, analog, differential, current-feedback audio preamplifiers. When used in conjunction with an appropriate analog gain block (e.g. THAT1570, THAT1580 or THAT1583), the 5173 can digitally control gain from 0dB to 60dB in 3dB steps, while preserving low noise and distortion. It operates from $\pm 5V$ to $\pm 17V$ supplies, supporting input signal levels as high as +27 dBu (at 0dB gain, $\pm 17 V$) without an input pad. A

differential servo reduces output offsets to less than 1.75mV.

The THAT5173-DEMO Board demonstrates the 5173 mated with either the 1570, 1580 or 1583 mic preamplifier IC in a typical circuit. An easy to use USB Graphical User Interface provides total control over all 5173 features. Developers can take advantage of the generous prototyping area to customize the circuit for their own application.

Connections

Power

The USB interface runs on USB bus power, but the rest of the demo board requires an external power supply. +/-15 V (maximum +/-17V) supplies the analog circuitry. +48V phantom power is input (not generated on the board) and switched on and off via the on-board Phantom Power switch. Note that the ground return for +48V phantom power is via the CHAS (chassis ground) connector. The +5V input is regulated on board to 3.3V and supplies the digital logic.

Audio Input

The Neutrik combo connector accepts an XLR or ¼" TRS cable. The ¼" TRS signal path includes a 20dB pad in order to support line levels.

Audio Output

Separate XLR and ¼" TRS connectors are wired in parallel. differential attenuator/ output buffer (U3) adds a small amount of noise and

distortion to the signal and it is therefore recommended that test points TP10 - TP11 be used to measure performance of the mic preamp circuit in isolation.

USB

A PC must be plugged into the demo board via USB in order to control parameters in the 5173 (e.g. gain). Take care not to hot plug the demo board while the GUI software is running as this will sometimes crash the Windows drivers.

General Purpose Outputs (GPO)

The GPO3:0 pins are connected to header P6. P6 is conveniently located near the prototyping area, so the user can easily connect optional circuitry to them. Note that the GPO pins are also connected to LEDs, D1-D4, and pull up and pull down resistors which set the 5173 device address during reset. Consideration must be given to how any application circuitry that is added interacts with these other functions.

Hardware Set-up

1. Connect a power supply to the V+, V-, +5V, +48V, CHAS and GND connectors. Do not turn on power yet.
2. Plug in the audio input and output
3. Attach a USB cable to the demo board, but do not plug it into the PC yet
4. Turn on the power supply
5. Turn on phantom power to microphone (if appropriate)

6. Plug USB cable into PC. Windows should go through its procedure for discovering the new USB peripheral and loading its driver.

7. Once the Windows driver has been loaded, launch the THAT Corporation MicPreController GUI application. See software section (below) for further instructions on operating the GUI.

8. When finished, close the MicPreController GUI first, then power down the demo board.

Software Set-up

If you see an error during installation

The 5173 Demo Board GUI application requires Microsoft .NET Framework 3 or later to be installed on your computer. If you see an error message during installation stating the application could not be installed, 99% of the time it's because you don't have .NET. Please visit: <http://www.microsoft.com/download/en/details.aspx?id=17718> and install the latest version.

Installing the 5173 Demo Board Software

NOTE: Do NOT plug the demo board into your PC yet. We'll tell you when to do that.

PC Software Installation Process

1. Get the software, a single file named THAT5173_Demo_Setup.exe. The software is available via download from the THAT Corporation website on the following page: www.thatcorp.com/Demonstration_Boards.shtml



Figure 2. THAT5173_Demo_Setup.exe setup program in a folder

2. Double click the THAT5173_Demo_Setup.exe icon. Windows might warn you: "The publisher could not be verified. Are you sure you want to run this software?" (Figure 3). This is a standard security warning presented by Windows when files from unknown origins are opened. Consider where you got this. On a bit torrent file sharing site? Don't open it. From us, click RUN.



Figure 3. Windows warning, just click RUN.

3. Next, you must tell Windows to go ahead and install the Software, as shown in Figure 4. Click INSTALL.

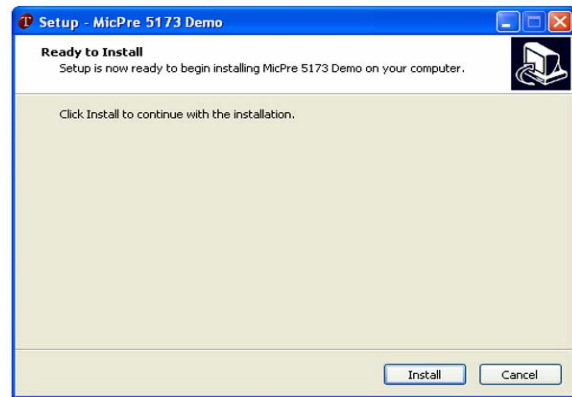

Figure 4. Start the installation process (USB drivers first)

4. You should see the automated wizard step through a series of steps as it plugs in the requisite USB drivers. When it's done, the wizard invites you to install the GUI, as shown in Figure 5. Click NEXT.



Figure 5. Starting the GUI installation process

5. The first thing the wizard asks is where you want to put the GUI (Figure 6). We recommend a THAT Corp folder, as shown in the figure. Navigate to where you want the GUI to be installed, and then click NEXT.

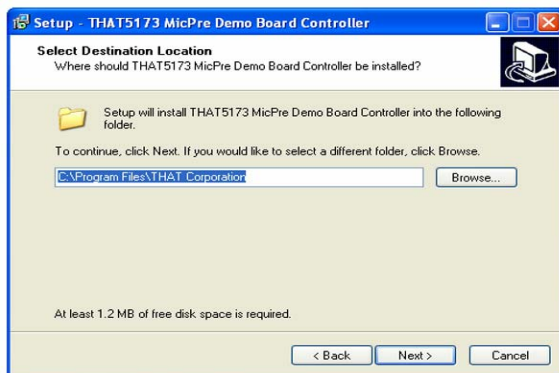

Figure 6. Selecting the software hard disk location

6. Next, Windows asks where it should put the Shortcut icons for the GUI (Figure 7). If you agree with our recommendation, just click NEXT. Otherwise, change this setting to what you want and then click NEXT.

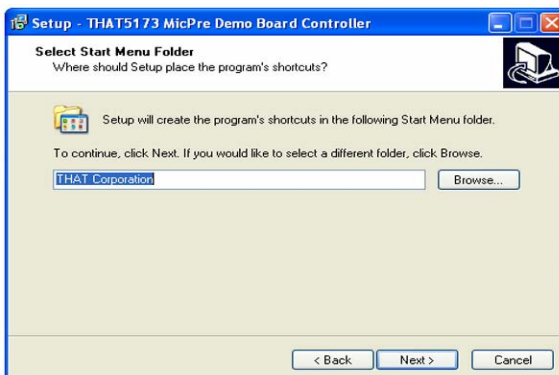

Figure 7. Selecting the start menu folder

7. Now Windows asks if you want a Desktop icon (Figure 8). We will leave that to you to decide (this is your homework). Once you've made your decision, click NEXT.

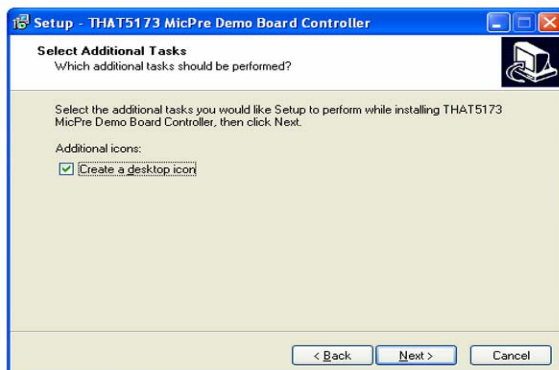

Figure 8. Selecting a desktop icon

8. Finally, the wizard will stop asking you questions and get on with the business of installing the GUI, as shown in Figure 9. Click INSTALL.

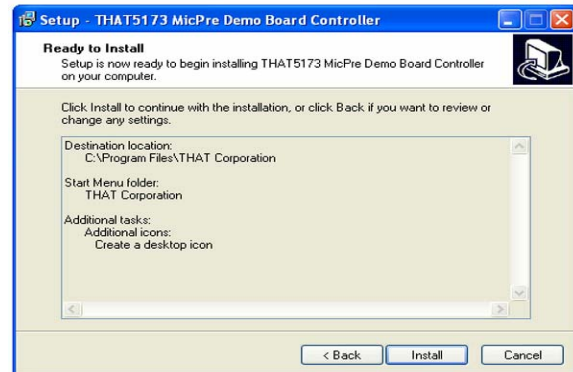

Figure 9. Ready to install

9. When the wizard is finished, you should see the final dialog box shown in Figure 10. Click FINISH.



Figure 10. Finishing the GUI installation process

10. The software installation wizard is done now, but there is one final step. Windows and the 5173 Demo Board must see each other for the first time. Their first encounter is special because it's when Windows discovers a new USB device and attaches those new drivers you just installed to it. It is not required that the Demo Board be connected to an external supply for this process to work, the USB interface on the Demo Board is actually bus-powered by USB. So, plug the Demo Board into your PC and watch them get to know each other (you'll see little messages flash in the lower right corner). Hopefully Windows will report a happy marriage. If not, get a fresh cup of coffee (or whatever you drink in distress), and call our tech support hotline.

11. That's it. You're done. Enjoy.

Operation

1. Apply power to the demo board, then plug the demo board into the PC via USB.

2. Launch the MicPreController GUI application.

3. The USB interface on the demo board will appear in Windows as a new COM port.

4. The GUI should now be connected to the demo board and ready to control its parameters. The GPO 0 check box is selected by default, and the GPO 0 LED should now be lit on the demo board indicating that communications have been established. If the LED is not turned on, or anytime USB communication has been disrupted, use the "Reconnect" command from the Port drop down menu to re-establish the USB connection.

5. Select "Update immediately" or "Update on zero crossings" from the Gain Mode and GPO Mode drop down menus.

6. Move the gain slider to adjust gain of the 5173. Gains are continuously adjusted as you move the slider. You may also adjust the gain slider by first giving it scope (clicking it with the mouse) and then pressing the UP and DOWN arrow keys on your computer keyboard, or by clicking the up or down arrow buttons next to the numeric gain text box below the gain slider.

Jumper Options

T-Bias Jumper, P7

The input circuit provides a jumper (P7) which enables/disables the "T-Bias" function. With a shunt installed on P7, T-Bias is disabled and the circuit provides a 2k Ω differential input impedance to the XLR input. With the shunt removed from P7, T-Bias is enabled and provides a high common mode impedance (ideal for both mic and line inputs) but maintains a modest differential impedance.

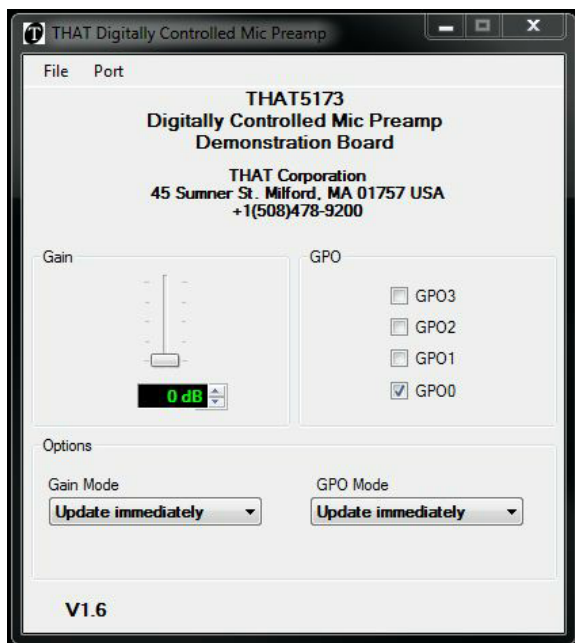
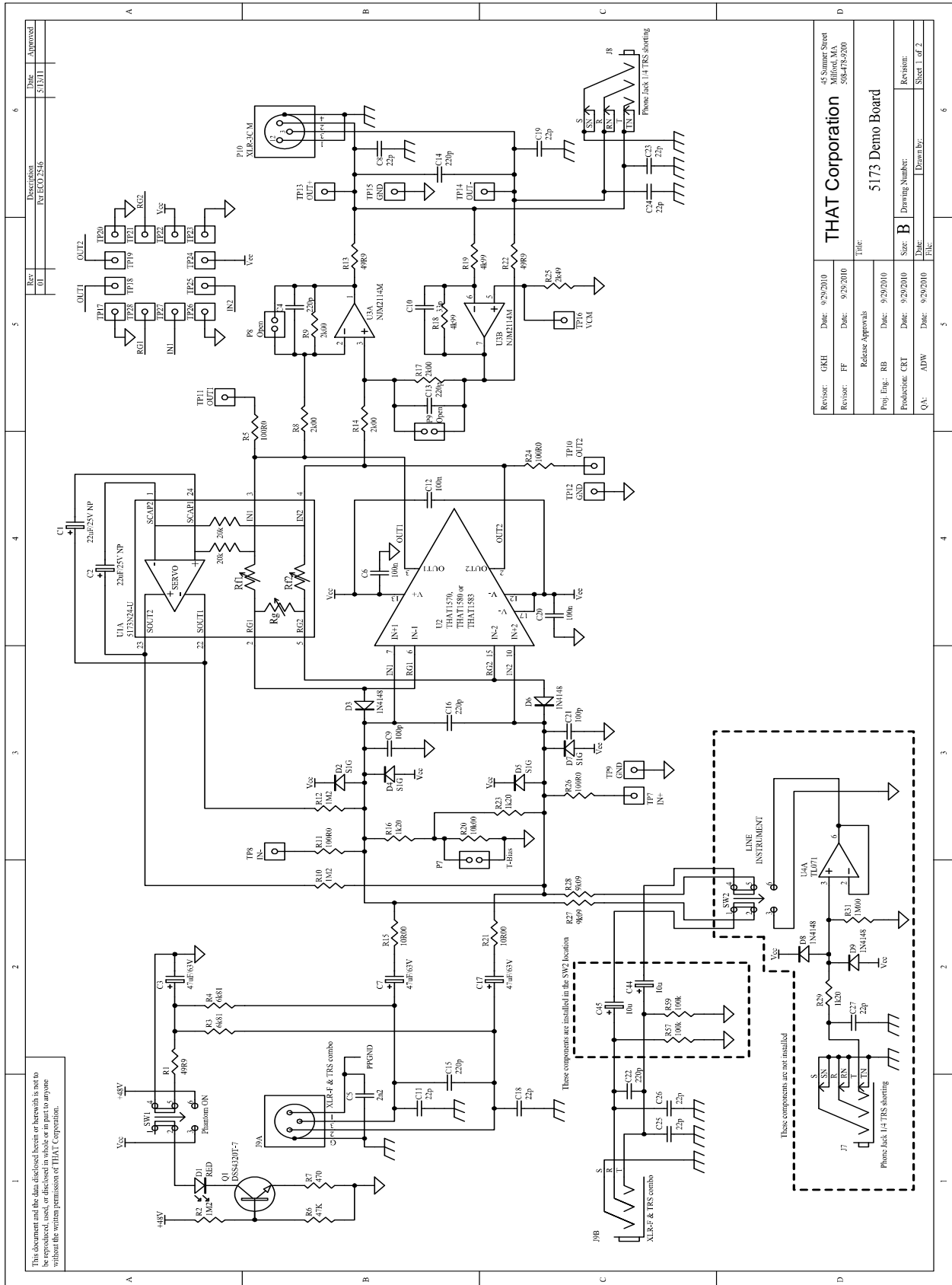
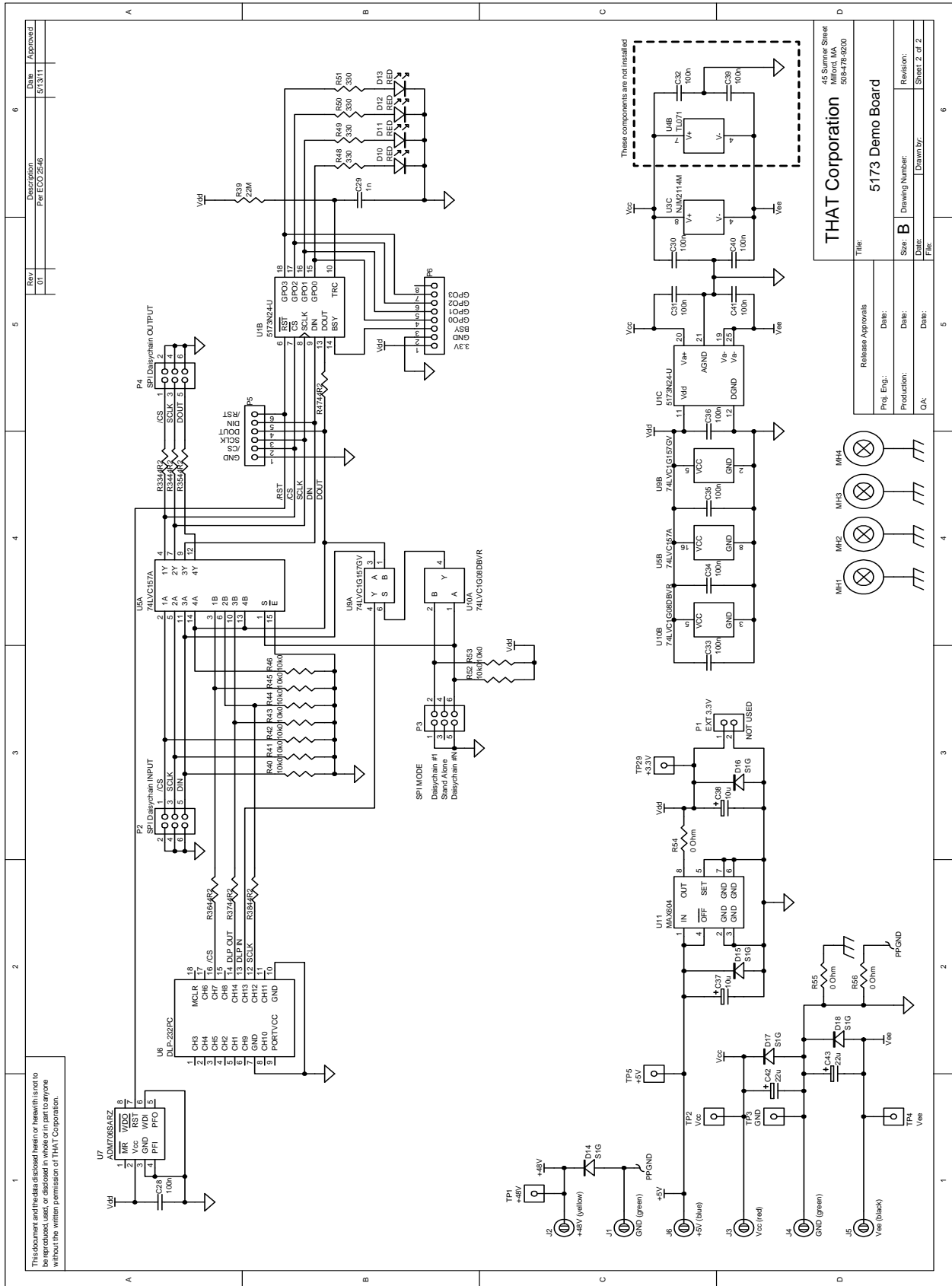

Figure 11. Control GUI

Appendix A. Schematic (1 of 2)



Appendix A. Schematic (2 of 2)



This document and the data disclosed herein or herewith is not to be reproduced, used, or disclosed in whole or in part to anyone without the written permission of THAT Corporation.

THAT Corporation
45 Summer Street
Milford, MA 01757-1656
508-478-9200

5173 Demo Board

Title:	5173 Demo Board
Release Approvals:	
Prog. Eng.:	
Production:	
Date:	
Size:	B
Drawing Number:	
Rev.:	2 of 2
Drawn by:	
QA:	

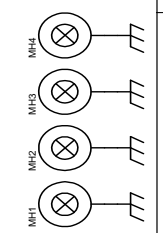

Appendix B. Bill of Materials

Item	Qty	Reference	Value	Description	Mfr	Mfr P/N
1	3	R54, R55, R56	0 Ohm	Resistor 100mW 5% Thick Film 200ppm 0603	Vishay Dale	CRCW0805000ZRT1
2	9	R40, R41, R42, R43, R44, R45, R46, R52, R53	10k0	Resistor 100mW 1% Thick Film 100ppm 0603	Vishay Dale	CRCW06031002FRT1
3	7	R33, R34, R35, R36, R37, R38, R47	44R2	Resistor 100mW 1% Thick Film 100ppm 0603	Xicon	302-44.2
4	2	R15, R21	10R00	Resistor 1/4W 0%1 MF 50ppm axial	VPR	A010.00M3EB
5	2	R3, R4	6K81	Resistor 1/4W 0%1 MF 25 ppm axial	IRC	RC55LF-D-6K81-B-B
6	1	R1	49R90	Resistor 1/4W 0%1 MF 25 ppm 1206	Vishay Dale	TNPW120649R9BEEN
7	2	R13, R22	49R90	Resistor 1/10W 0%1 Thin Film 25 ppm 0805	Stackpole Electronics	RNCS0805BKE49R9
8	2	R27, R28	6k04	Resistor 63mW 1% Thin Film 100ppm 0603	Venkel, Ltd.	TFRC0603-16W-E-6041FT
9	4	R5, R11, R24, R26	100R0	Resistor 100mW 1% Thin Film 25ppm 0805	VPR	A100.00E3EF
10	1	R20	10k00	Resistor 100mW 0%5 Thin Film 25ppm 0805	Susumu Co	RR1220P-103-D
11	3	R16, R23, R29	1k20	Resistor 0.25W 0%1 Thin Film 25ppm 0805	Susumu Co	RGH2012-2E-P-122-B
12	1	R31	1M00	Resistor 0.125W 0%1 Thin Film 25ppm 0805	Bourns	CRT0805-BY-1004ELF
13	3	R2, R10, R12	1M2	Resistor 0.125W 1% TF 100ppm 0805		
14	4	R8, R9, R14, R17	2K00	Resistor 100mW 0%1 Thin Film 25ppm 0805	Susumu	RR1220P-202-B-T5
15	2	R18, R19	4k99	Resistor 100mW 0%5 Thin Film 25ppm 0805	Susumu	RR1220P-4991-D-M
16	1	R6	47k0	Resistor 125mW 1% TF 100ppm 0805	Yageo	RC0805FR-0747KRL
17	1	R7	470R	Resistor 125mW 1% TF 100ppm 0805	Yageo	RC0805FR-07470RL
18	1	R25	2k49	Resistor 125mW 1% Thin Film 100ppm 0805	Stackpole Electronics	RNCP0805FTD2K49
19	4	R48, R49, R50, R51	330R	Resistor 125mW 1% TF 100ppm 0805	Yageo	RC0805FR-07330RL
20	1	R39	22M	Resistor 125mW 1% TF 100ppm 0805	Panasonic	ERJ-6GEYK226V
21	1	C29	1n	Capacitor 10% 50V X7R CM 0603	AVX Corporation	06035C102KAT2A
22	11	C28, C30, C31, C32, C33, C34, C35, C36, C39, C40, C41	100n	Capacitor 10% 50V X7R CM 0603	Murata Electronics	GRM188R71H104K
23	3	C6, C12, C20	100n	Capacitor 10% 50V X7R CM 0805	Murata Electronics	GRM21BR71H104KA01L
24	2	C9, C21	100p	Capacitor 10% 50V X7R CM 0805	Murata Electronics	GRM2165C1H101JA01D
25	6	C4, C13, C14, C15, C16, C22	220p	Capacitor 5% 50V NP0 CM Low ESR 0805	Panasonic	ECJ-2VC1H221J
26	9	C8, C11, C18, C19, C23, C24, C25, C26, C27	22p	Capacitor 10% 50V NP0 CM Low ESR 0805	Panasonic	ECJ-2VC1H220J
27	1	C10	33p	Capacitor 5% 50V NP0 CM Low ECR 0805	Panasonic	ECJ-2VC1H330J
28	1	C5	2n2	Capacitor 20% 100V X7R CM 0805	Johanson Dielectrics Inc	101X15W222MV4E
29	2	C37, C38	10u	Capacitor 20% 25v aluminum SMT	United Chemi-Con, Inc.	EMVA250ADA100MD55G
30	2	C42, C43	22u	Capacitor 20% 25v aluminum Low Imp SMT	Panasonic	EEV-FC1E220P
31	3	C3, C7, C17	47u	Capacitor 20% 63V AL Low ESR SMT	Panasonic	EEV-TG1J470P
32	2	C1, C2	22u	Capacitor 20% 25v aluminum NP SMT	Nichicon	UWP1C220MCL1GB
33	9	D2, D4, D5, D7, D14, D15, D16, D17, D18	S1G	Diode rectifier 1A 400V DO-214AC	Diodes, Inc.	S1G-13-F
34	4	D3, D6, D8, D9	1N4148	DIODE SWITCHING 75V 150MA 0603	Comchip Technology Corporation	CDSU4148
35	1	Q1	DSS4320T-7	TRANS BIPO NPN 20V 2A SOT-23	Diodes, Inc.	DSS4320T-7
36	5	D1, D10, D11, D12, D13	Red	LED High Brightness	Rohm	SLA-560LT3F
37	1	U7	ADM706SAR	IC 3V uProcessor Supervisory Circuit SOIC-8	Analog Devices	ADM706SARZ
38	1	U11	MAX604CSA	IC Voltage Regulator Low Drop 3.3V SO-8	Maxim / Dallas	MAX604CSA
39	1	U4	TL071IDT	IC Low Noise JFETsingle Op Amp SOIC-8	ST Microelectronics	TL071IDT
40	1	U3	NJM2114M	IC Op Amp dual low noise DMP-8	NJR Corporation	NJM2114M
41	1	U5	74LVC157A DB,112	IC Quad 2 Input Multiplexer	NXP	74LVC157ADB,112

Item	Qty	Reference	Value	Description	Mfr	Mfr P/N
42	1	U9	74LVC1G157GV,125	IC Single 2 Input Multiplexer	NXP Semiconductors	74LVC1G157GV,125
43	1	U10	SN74LVC1G08DBVR	IC Single 2 input positive AND GATE SMT	Texas Instruments	SN74LVC1G08DBVR
44	1	U2	1570N16-U 1580N16-U or 1583N16-U	IC Differential Output Mic Pre QFN16 RoHS	THAT Corporation	1570N16-U 1580N16-U or 1583N16-U
45	1		470645-00	Label white polyester 1.07" x 0.24"		
46	2	SW1, SW2	DPDT	Switch PUSHBUTTON 2 POLE	E-Switch	PBH2UEENAGX
47						
48	1	J6	Binding Post	Connector 1p female chassis mount blue	Pomona Electronics	3760-6
49	1	J2	Binding Post	Connector 1p female chassis mount yellow	Pomona Electronics	3760-4
50	3	P2, P3, P4	3 x 2	Connector 6p male gold 0.1"	3M	2306-6121TG
51	3	P7, P8, P9	2 x 1	Connector 2p male gold 0.1"	Samtec USA	TSW-102-07-G-S
52	1	P5	6 x 1	Connector 6p male gold 0.1"	Molex	22-28-4063
53	1	P6	8 x 1	Connector 8p male gold 0.1"	Samtec USA	TSW-108-07-G-S
54	1	P1	2 x 1	Connector 2p male locking gold 0.1"	Molex	22-11-2022
55	1	J3	Binding Post	Connector 1p female chassis mount red	Pomona Electronics	3760-2
56	2	J1, J4	Binding Post	Connector 1p female chassis mount green	Pomona Electronics	3760-5
57	1	J5	Binding Post	Connector 1p female chassis mount black	Pomona Electronics	3760-0
58	16	TP1, TP2, TP3, TP4, TP5, TP7, TP8, TP9, TP10, TP11, TP12, TP13, TP14, TP15, TP16, TP29	1 x 1	Connector 1p Test Point SMT 0.015 thick	Keystone Electronics Corporation	5016
59	1	P10	XLR-3C	Connector 3p male right angle	Neutrik USA Inc.	NC3MAH
60	1	J9	XLR-combo stereo	Connector 3p female right angle	Neutrik USA Inc.	NCJ6FI-H
61	2	J7, J8	1/4" stereo slim jack	Connector Phone 3p female right angle	Neutrik USA Inc.	NRJ6HF-1
62	4	MH1, MH2, MH3, MH4	#4-40 x 3/4"	Standoff swage 1/4" hex aluminum	Concord Electronics Corporation	627A-9486-16
63						
64	1	U6	DLP-232PC	PCB Assembly, USB Microcontroller Module	DLP Design, Inc	DLP-232PC
65	1	U1	5173N24-U	IC Audio PreAmp Digital Controler QFN24 RoHS	THAT Corporation	5173N24-U

Appendix C. PCB Layout (1 of 3)

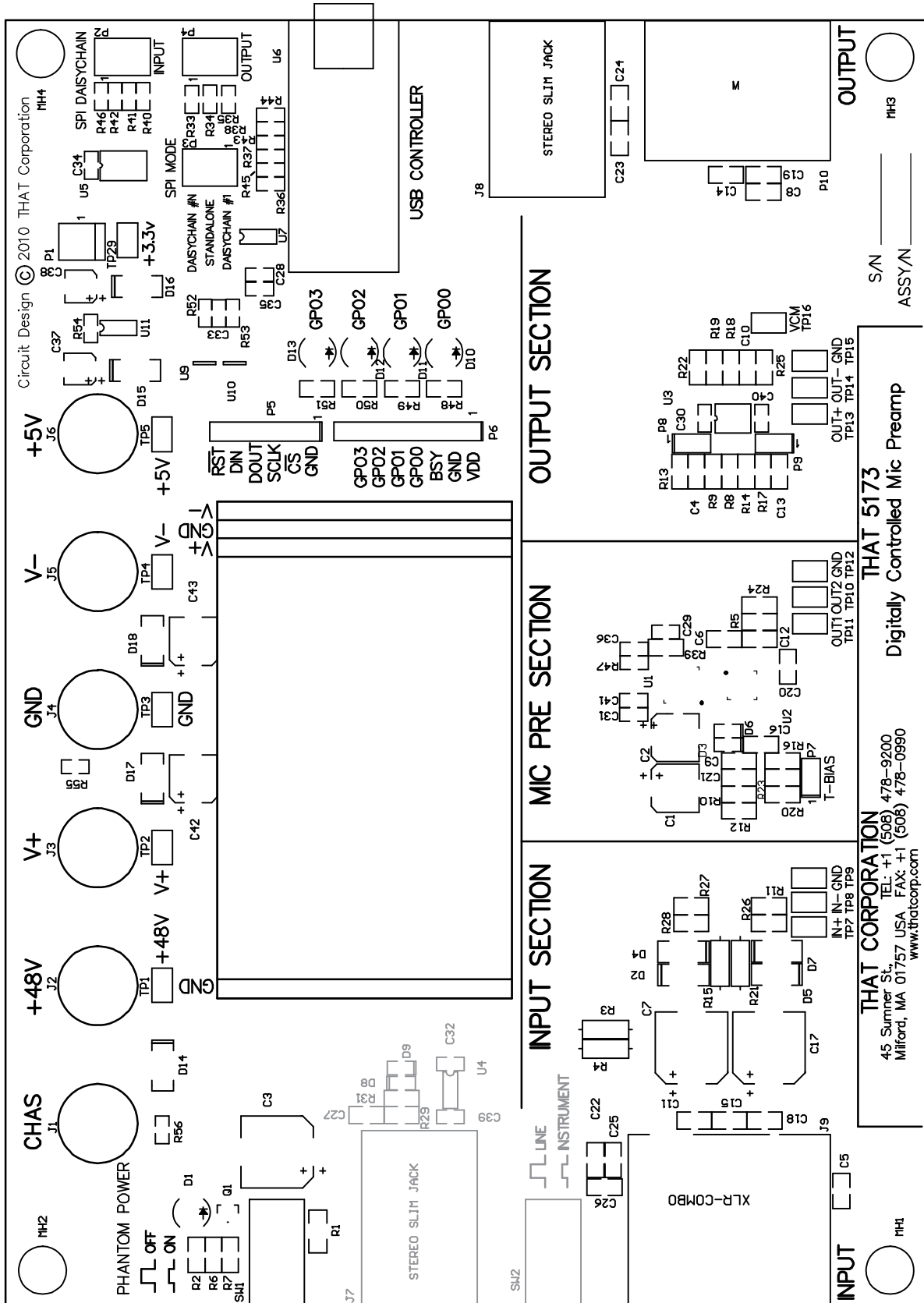

Appendix C. PCB Layout (2 of 3)

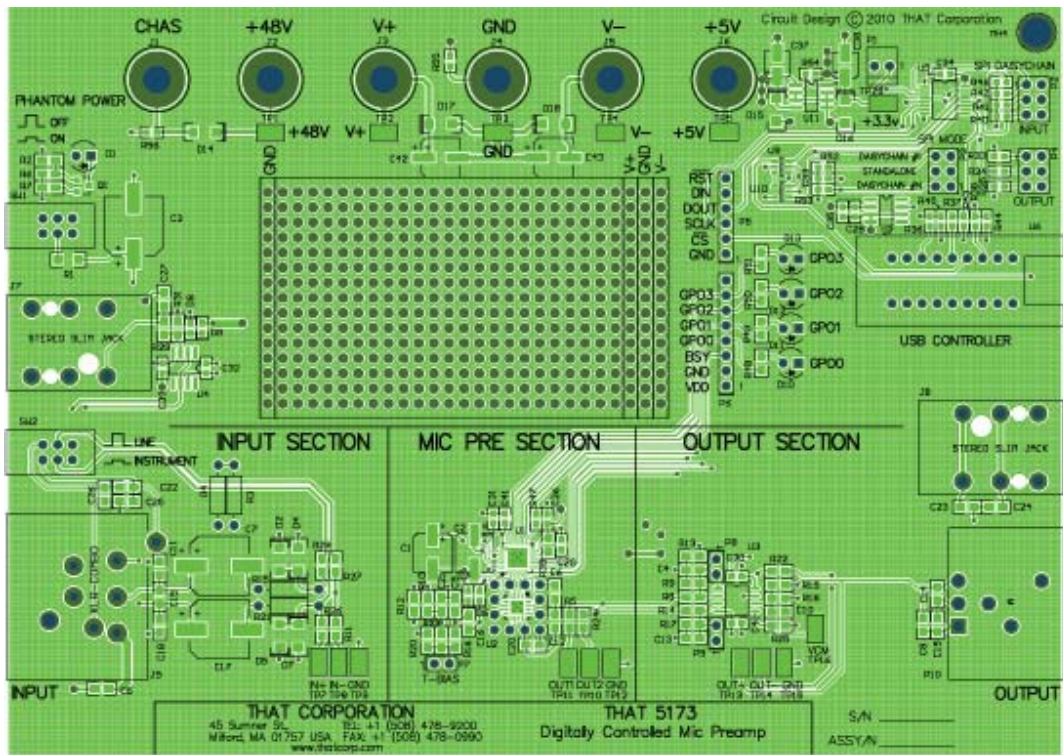

Layer 1 (Top with component screen)

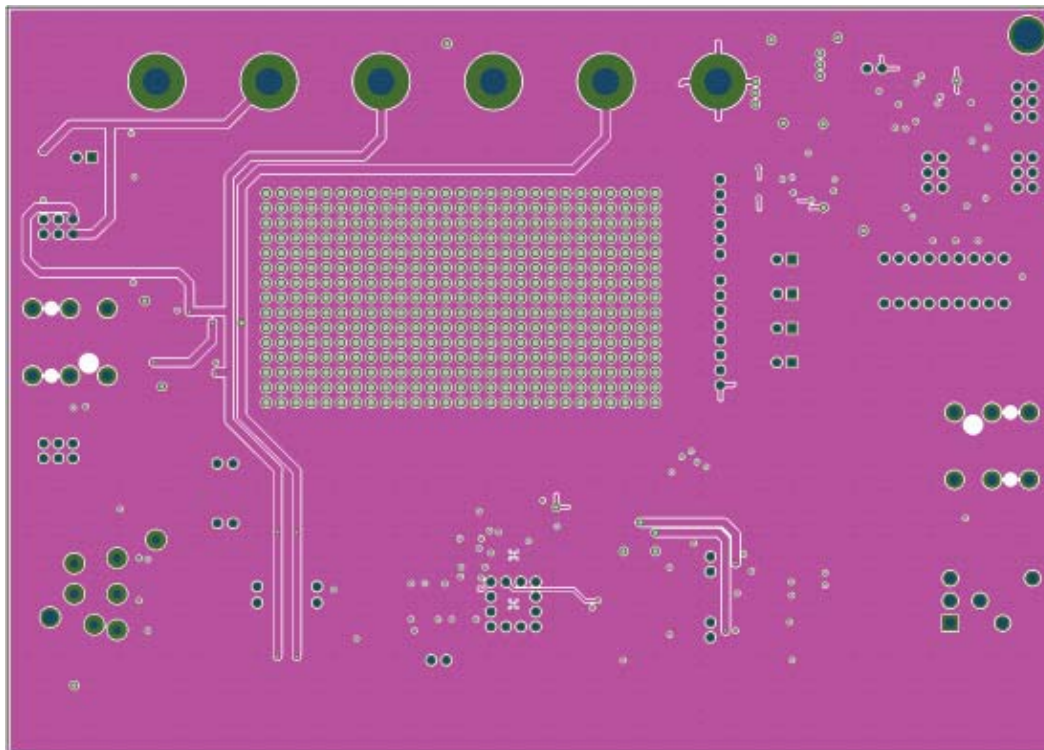

Layer 2 (Power)

Appendix C. PCB Layout (3 of 3)

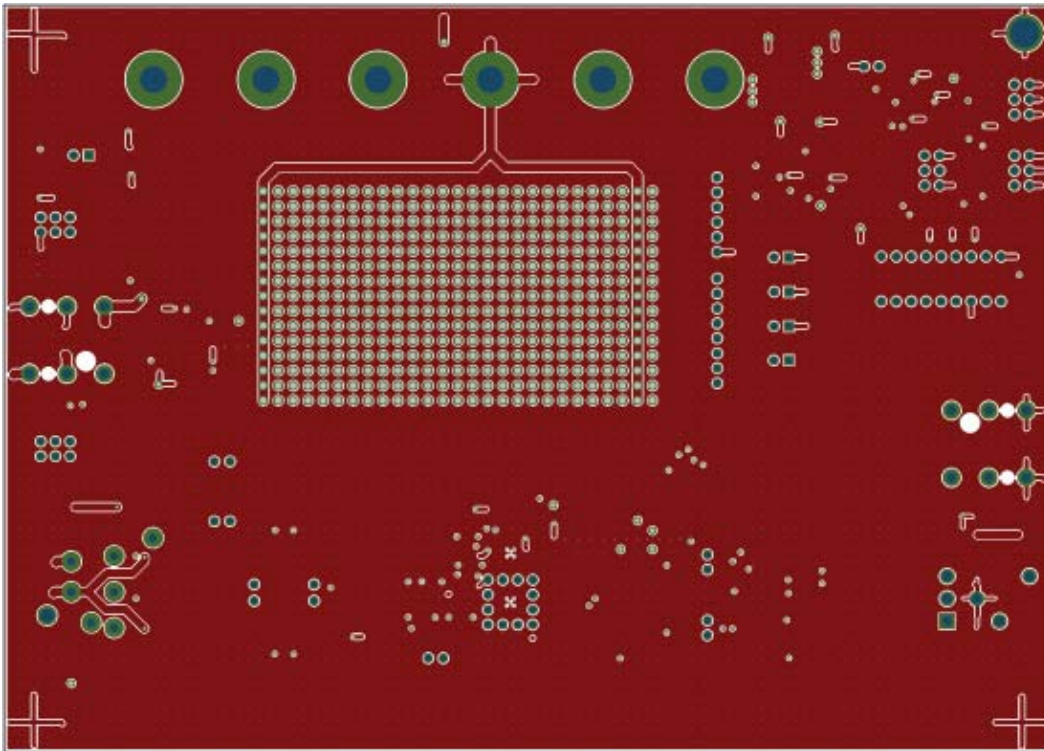

Layer 3 (Ground)

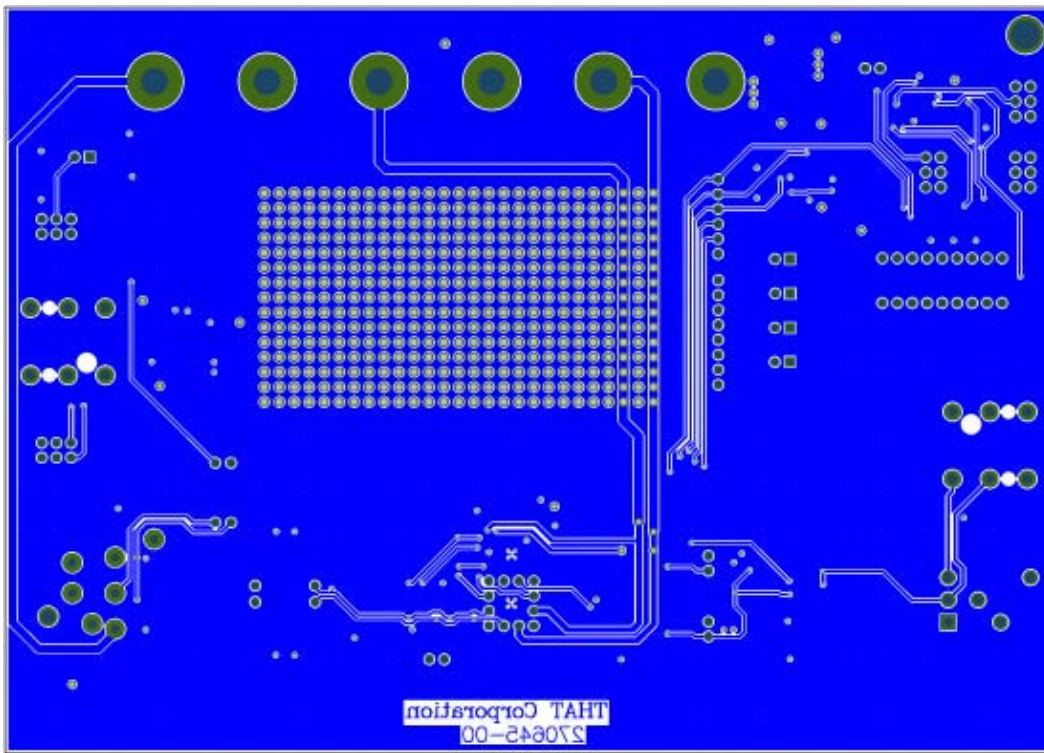

Layer 4 (Bottom)

Appendix D. 5173 + 1570 Specifications¹

Parameter	Symbol	Typical	Units
Power Supply Voltage	V+ - V-	±15	V
Maximum Input Level (V+ /V- = ±15V)	V _{in-BAL}	+26.8	dBu
Maximum Differential Output Level (V+ /V- = ±15V)	V _{OUT}	+26.8	dBu
Gain (input to output)	A _{dB}	0 to 60 in 3dB steps	dB
Gain error (all settings)	A _{err}	±0.2 (typical)	dB
Total Harmonic Distortion + N (V _{OUT} = +16dBu (5V _{RMS}); R _L = 10kΩ; C _L = 10 pF; f = 1kHz; BW = 22 kHz)	THD+N	0.0005 (0dB gain) 0.0005 (+21dB gain) 0.001 (+39dB gain) 0.006 (+60dB gain)	%
Equivalent Input Noise, Main Output (R _{SOURCE} =150 Ω, BW=22kHz)	EIN	-127.3 (+60dB gain) -125.3 (+39dB gain) -117.4 (+21dB gain) -104.8 (0dB gain)	dBu
Equivalent Input Noise, 1570 Output (R _{SOURCE} =150 Ω, BW=22kHz)	EIN	-127.3 (+60dB gain) -125.3 (+39dB gain) -117.5 (+21dB gain) -106 (0dB gain)	dBu
Supply Current	I _{CC} ; -I _{EE} , I _{DD}	27 (V+ supply) 27 (V- supply) 15 (+5V supply, all LEDs on)	mA

1. All specifications are subject to change without notice.

2. Unless otherwise specified, T_A=25°C, V_{CC}=+15V, V_{EE}=-15V, V_{DD}=+3.3V

Appendix E. 5173 + 1583 Specifications¹

Parameter	Symbol	Typical	Units
Power Supply Voltage	V+ - V-	±15	V
Maximum Input Level (V+ /V- = ±15V)	V _{in-BAL}	+26.4	dBu
Maximum Differential Output Level (V+ /V- = ±15V)	V _{OUT}	+27.8	dBu
Gain (input to output)	A _{dB}	0 to 60 in 3dB steps	dB
Gain error (all settings)	A _{err}	±0.2 (typical)	dB
Total Harmonic Distortion + N (V _{OUT} = +16dBu (5V _{RMS}); R _L = 10kΩ; C _L = 10 pF; f = 1kHz; BW = 22 kHz)	THD+N	0.001% (0dB gain) 0.001% (+21dB gain) 0.001% (+39dB gain) 0.008% (+60dB gain)	%
Equivalent Input Noise, Main Output (R _{SOURCE} =150 Ω, BW=22kHz)	EIN	-124.8 (+60dB gain) -122.4 (+39dB gain) -112.3 (+21dB gain) -99.2 (+0dB gain)	dBu
Equivalent Input Noise, 1583 Output (R _{SOURCE} =150 Ω, BW=22kHz)	EIN	-124.8 (+60dB gain) -122.4 (+39dB gain) -112.3 (+21dB gain) -99.3 (+0dB gain)	dBu
Supply Current	I _{CC} ; -I _{EE} , I _{DD}	27 (V+ supply) 27 (V- supply) 15 (+5V supply, all LEDs on)	mA

1. All specifications are subject to change without notice.

2. Unless otherwise specified, T_A=25°C, V_{CC}=+15V, V_{EE}=-15V, V_{DD}=+3.3V

Appendix F. 5173 + 1580 Specifications¹

Parameter	Symbol	Typical	Units
Power Supply Voltage	V+ - V-	±15	V
Maximum Input Level (V+ /V- = ±15V)	V _{in-BAL}	+26.0	dBu
Maximum Differential Output Level (V+ /V- = ±15V)	V _{OUT}	+26.8	dBu
Gain (input to output)	A _{dB}	0 to 60 in 3dB steps	dB
Gain error (all settings)	A _{err}	±0.2 (typical)	dB
Total Harmonic Distortion + N (V _{OUT} = +16dBu (5V _{RMS}); R _L = 10kΩ; C _L = 10 pF; f = 1kHz; BW = 22 kHz)	THD+N	0.0006 (0dB gain) 0.0005 (+21dB gain) 0.001 (+39dB gain) 0.005 (+60dB gain)	%
Equivalent Input Noise, Main Output (R _{SOURCE} =150 Ω, BW=22kHz)	EIN	-127.3 (+60dB gain) -125.3 (+39dB gain) -117.4 (+21dB gain) -104.8 (0dB gain)	dBu
Equivalent Input Noise, 1570 Output (R _{SOURCE} =150 Ω, BW=22kHz)	EIN	-127.3 (+60dB gain) -125.3 (+39dB gain) -117.5 (+21dB gain) -106 (0dB gain)	dBu
Supply Current	I _{CC} ; -I _{EE} , I _{DD}	27 (V+ supply) 27 (V- supply) 15 (+5V supply, all LEDs on)	mA

1. All specifications are subject to change without notice.

2. Unless otherwise specified, T_A=25°C, V_{CC}=+15V, V_{EE}=-15V, V_{DD}=+3.3V

FCC Warning

This device is only intended for laboratory test environments. It may radiate radio frequency energy and has not been tested for compliance with subpart

J of part 15 of the FCC regulations. Operation of this device in other environments may cause interference with radio communications.

Revision History

Revision	ECO	Date	Changes	Page
00	—	04/09/2012	Released	—
01	2757	02/05/2013	Added references to THAT1583	—
02	2923	05/28/2015	Added references to THAT1580	—



Стандарт Электрон Связь

Мы молодая и активно развивающаяся компания в области поставок электронных компонентов. Мы поставляем электронные компоненты отечественного и импортного производства напрямую от производителей и с крупнейших складов мира.

Благодаря сотрудничеству с мировыми поставщиками мы осуществляем комплексные и плановые поставки широчайшего спектра электронных компонентов.

Собственная эффективная логистика и склад в обеспечивает надежную поставку продукции в точно указанные сроки по всей России.

Мы осуществляем техническую поддержку нашим клиентам и предпродажную проверку качества продукции. На все поставляемые продукты мы предоставляем гарантию .

Осуществляем поставки продукции под контролем ВП МО РФ на предприятия военно-промышленного комплекса России , а также работаем в рамках 275 ФЗ с открытием отдельных счетов в уполномоченном банке. Система менеджмента качества компании соответствует требованиям ГОСТ ISO 9001.

Минимальные сроки поставки, гибкие цены, неограниченный ассортимент и индивидуальный подход к клиентам являются основой для выстраивания долгосрочного и эффективного сотрудничества с предприятиями радиоэлектронной промышленности, предприятиями ВПК и научно-исследовательскими институтами России.

С нами вы становитесь еще успешнее!

Наши контакты:

Телефон: +7 812 627 14 35

Электронная почта: sales@st-electron.ru

Адрес: 198099, Санкт-Петербург,
Промышленная ул, дом № 19, литера Н,
помещение 100-Н Офис 331