

Relevant Products:

- CTSR218

Relevant Resources:

- CT5218 Datasheet
- CTD205 Energy Meter Demo Board

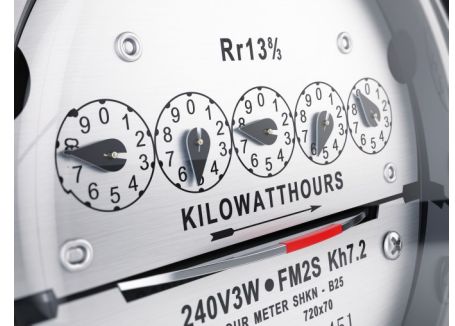

Introduction

This report discusses the use of Crocus Technology’s Tunneling Magnetoresistive (TMR) sensors to measure current in energy meters. It describes the architecture and operation of Crocus’s TMR sensors; the design and performance of the CTD203, a current sensing demonstration board; and discusses some external influence factors.

Current flowing in a conductor produces a magnetic field whose relationship to the direction and magnitude of the current are well known. The direction of the magnetic field is indicated by the right-hand rule, which states that if a current carrying conductor is grasped in the right hand with the thumb pointing in the direction of current flow, the fingers will indicate the direction of the magnetic field. This is illustrated in Figure 1.

The field strength at any fixed point will be directly proportional to the magnitude of the current. For an infinitely long straight conductor of infinitesimal diameter, the flux density follows Ampere’s law, expressed as follows:

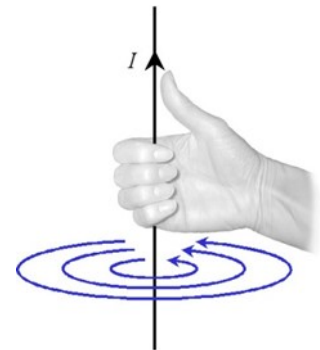

Figure 1: Right Hand Rule

$$B = \frac{\mu_0 I}{2\pi R}$$

where, B is the magnetic flux density in Tesla [T]

μ_0 is the permeability of free space (1.256637*10⁻⁶ T m/A)

R is the radial distance from the center of the conductor

This relationship makes it possible to calculate the current’s magnitude and direction by measuring the magnitude and direction of the magnetic field produced by the current, allowing the use of magnetic sensors to measure current.

Magnetic Logic Unit™ (MLU™) Sensors

Crocus MLU sensors are based on the tunneling magnetoresistance (TMR) effect. A magnetic tunnel junction (MTJ) comprises two magnetic layers separated by a thin insulating layer. In one layer, called the reference layer, the magnetic orientation is fixed. In the other layer, called the sensing layer, the magnetic orientation changes when an external magnetic field is present. When a differential voltage exists between the two layers, electrons tunnel through the insulator from one layer to another. The freedom of electrons to tunnel through the insulator depends upon the relative magnetic orientations of the two magnetic layers. When the magnetic orientations of the sensing layer and the reference layer are parallel electrons are freer to tunnel between layers, and the resistance is minimized. When the magnetic orientations are antiparallel electrons are less free to tunnel between the layers, and resistance is maximized.

When the relative orientations of the sensing and the reference layers are between parallel and antiparallel the resistance varies with the strength of an external magnetic field oriented along the junction's axis of sensitivity.

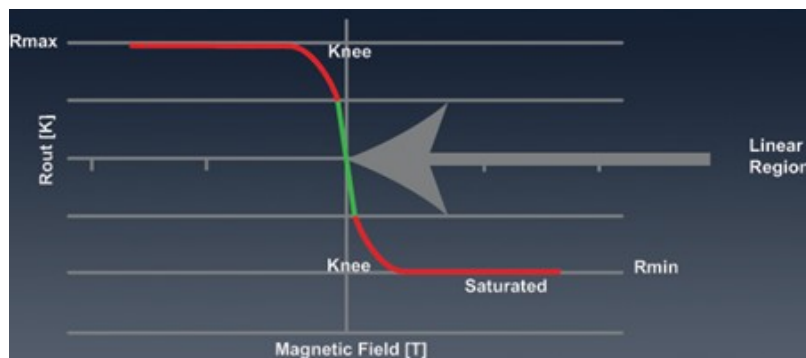

Figure 2: MTJ Response to a Magnetic Field

Figure 2 above shows how the resistance of an MTJ changes in response to the strength of a magnetic field aligned with the MTJ's reference layer. If a sufficient magnetic field exists in antiparallel with the orientation of the reference layer the orientation of the sensing layer will become antiparallel to the reference layer, and the MTJ reach its maximum resistance, shown on the left side of Figure 2. As the field to which the MTJ is exposed decreases in the antiparallel direction and increases in the parallel direction, the junction resistance decreases from its maximum towards its minimum resistance. The area of the response which is useful for linear sensing is that region, shown in green in Figure 2, in which the variation in resistance is linear with respect to the net magnetic field seen by the sensor.

MLU Based Current Sensors

Crocus's linear sensors comprise an MTJ cell and an input resistor or field line.

The CTSR218 sensor, when operating in the linear region of their operating curves, will show a 5% change in resistance in response to a 1mT change in flux density.

The field line is a conductor on the die at a distance on the order of 100Å from the MTJ cell. A current driven into the field line generates a magnetic field which can be used to bias the sensor to the center of the linear portion and to offset an externally applied field. Because of the field line's proximity to the sensor, a small current in the field line generates a significant magnetic field at the sensor. For the CTSR218, the field line produces a flux density at the sensor at approximately 4.71 Gauss/mA .

Closed-loop Implementation

The linear range of the CTSR218 magnetic sensor is specified as ± 1 mT.

While Ampere's law applies to an infinitely long, straight conductor of infinitesimal diameter, it can provide a useful approximation of the magnetic flux density due to current in a conductor of finite dimensions. Applying the formula shows that a 50A current will produce magnetic flux density of 1mT 10mm away from the conductor. For a sinusoidal current, a 50A peak current would correspond to 35.35 A_{RMS} . The ± 1 mT linear range of the sensor would indicate that in order to measure higher currents it would be necessary to move the sensor farther away from the conductor, as shown in Figure 3.

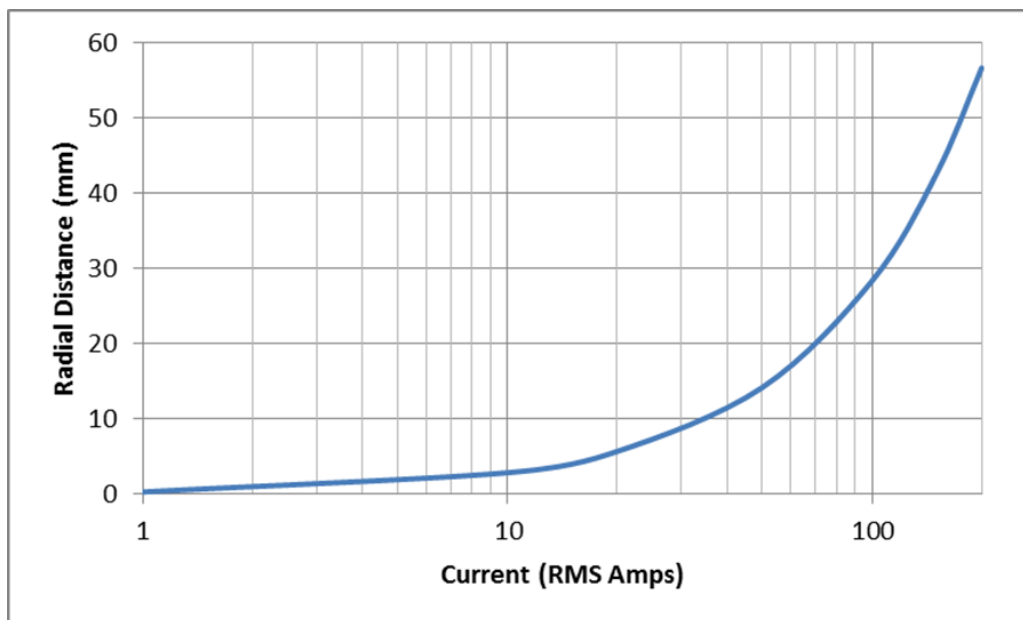

Figure 3: Radial Distance from Conductor for 1 mT Field

Figure 3 shows that in order to measure 100A_{RMS} with the ±1mT range the sensor would have to be placed nearly 30mm from the center of the conductor. For 200A_{RMS} the distance would have to be nearly 60mm. These distances are clearly impractical for utility meter implementation.

In order to extend the usable range of the sensor and to allow sensor placement at distances that are compatible with a utility meter enclosure, the TMR sensors are operated in the closed-loop implementation shown in Figure 4 below.

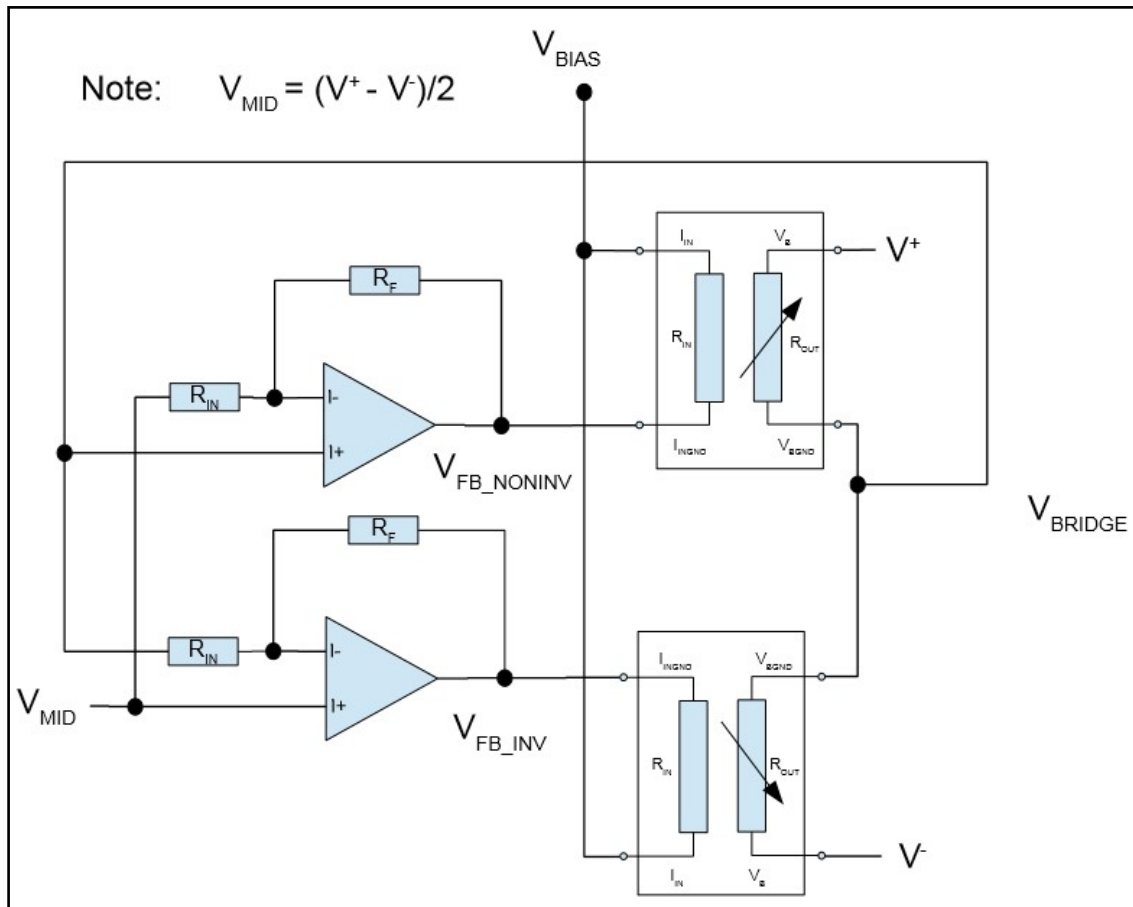

Figure 4: Recommended Closed-loop Sensor Circuit

Half-bridge Configuration

The sensors are connected in a half-bridge configuration, and are physically oriented so that their axes of sensitivity are collinear but with opposite polarities. This can be done with either two single-sensor CTR218s, or by using the CTR220, with two sensors in one package. The ends of the half bridge are connected to power supply rails, here designated as V+ and V-. With no external field applied, the bridge output (V_{BRIDGE}) will be at V_{MID}, which is the midpoint of V+ and V-.

This half-bridge connection provides two benefits. The sensitivity is increased because the resistances of the sensors change in opposite directions when a magnetic field is applied, that is, the resistance of one will increase while the other decreases. The configuration also provides temperature compensation. Because the temperature coefficients of resistance (TCR) of each sensor are very nearly equal, a change in temperature produces the same change in resistance in each sensor, so that the bridge output voltage does not change due to changes in temperature.

Field Bias

The CTSR218 and CT220 sensors are not at the center of their B-R transfer curves when no magnetic field is present. To bias the sensors into this region, a bias supply voltage, VBIAS drives 10mA into the field lines of each sensor. The magnetic field due to this field line current will bias both sensors to the midpoint of their B-R transfer curves, where the sensors exhibit the most nearly linear B-R response.

The Feedback Circuit

The feedback circuits control the currents in the field lines to cancel the externally applied magnetic field so that each sensor is returned to the midpoint of its B-R curve. The net magnetic field at the sensor is the vector sum of the external field and the field due to the field line current.

When no external magnetic field is applied to the sensors in the circuit of Figure 4, the magnetic field to which the sensors are exposed is that due to the bias current in their field lines. The resistance of each sensor is at the midpoint of its B-R transfer curve, which means that $V_{BRIDGE} = V_{MID}$. The bridge output, V_{BRIDGE} , is connected to the inputs of the two operational amplifiers, whose feedback reference is also V_{MID} . There is no differential voltage between the inputs of either amplifier, so that their outputs are also at V_{MID} .

Now consider that an external magnetic field is applied so that the resistance of the upper sensor decreases and that of the lower sensor increases. V_{BRIDGE} rises toward $V+$. The non-inverting feedback amplifier raises V_{FB_NONINV} , reducing the field line current in the upper sensor, causing the resistance of the upper sensor to increase. Simultaneously, the inverting amplifier lowers V_{FB_INV} , increasing the field line current in the lower sensor, causing its resistance to decrease. When the net magnetic field at each sensor returns to the bias point, the bridge returns to its balance point, and V_{BRIDGE} returns to V_{MID} . The feedback voltages V_{FB_NONINV} and V_{FB_INV} are proportional to the flux density of the external field, and if the external field is due to current in an external conductor, they are proportional to that current.

Current Measurement with Crocus MLU Sensors

Crocus's TMR sensors are used to measure current in a conductor by measuring the magnetic field generated by the current flowing in the conductor. The sensors operating in an open-loop implementation are quite limited in usable range, as discussed earlier, but the half-bridge, closed-loop configuration, enables measurement of much higher currents with better linearity than is possible in the open-loop case. In this configuration, the sensors are placed in relation to the conductor so that the magnetic lines of force that encircle the conductor are aligned with the sensors' axes of sensitivity, and so that both sensors are exposed to the same flux density at the same current level. The CTD205 current sensing demonstration board, which will be discussed later in this report, can be used in applications up to 110ARMS.

Current Measurement Requirements for Energy Meters

Accuracy standards for energy meters specify energy accuracy, not current measurement accuracy, but these are obviously related.

Standards developed by the American National Standards Institute (ANSI) specify the meter accuracy requirements for North America. In other world regions, standards may be those developed by the International Electrotechnical Commission (IEC), or nationally developed standards may prevail. Worldwide, ANSI and IEC standards are most prevalent. Table 1 shows excerpts of energy (Wh) accuracy requirements from ANSI and IEC standards

Table 1: Excerpt of Meter Accuracy Requirements

Standard	Meter Class	Accuracy Class ¹	ERROR ALLOWANCE (PF.=1)			
			MAXIMUM CURRENT	STARTING CURRENT ²	1A	1.5A – 100A
ANSI	100	0.5	100A	50mA	±1.0%	±0.5%
					2A	3A-200A
	200	0.5	200A	100mA	±1.0%	±0.5%
IEC	0.5	0.5	I _{MAX} ³	0.5%I _b ⁴	0.01I _b ≤ I ≤ 0.05I _b	0.05I _b ≤ I ≤ I _{MAX}
					±1.0%	±0.5%
	1	1	I _{MAX}	0.5%I _b 2	0.05I _b ≤ I ≤ 0.1I _b	0.1I _b ≤ I ≤ I _{MAX}
					±1.5%	±1
	2	2	I _{MAX}	0.5%I _b	±2.5%	±2.0%

Note 1: In the ANSI Standard 12.20, the meter class defines the maximum current, reference current and starting current. In the IEC standards the meter class defines the energy accuracy

Note 2: The lowest current at which the meter should register energy accumulation at PF=1

Note 3: I_{MAX} is the maximum current at which the meter is guaranteed to meet the accuracy class requirements. It is specified by the manufacturer. For IEC meters, typical values are below 100A

Note 4: I_b is the current at which the meter is calibrated and at which other tests are performed. It is specified by the manufacturer. Some typical values are 5A, 10A, 15A, 20A

Energy Calculation

In an electronic, or static meter, the metering chip measures voltage and current at each sampling interval T , producing a series of samples $v(t)$ and $i(t)$. These are multiplied to calculate instantaneous power as shown below:

$$P(t) = v(t) \times i(t)$$

$$E = \sum_{n=0}^{n=m-1} v(nT) \times i(nT)$$

Where, E is the energy in watt-seconds accumulated over m sampling periods
 T is the sample period in seconds
 $v(it)$ is the instantaneous voltage at time nT
 $i(it)$ is the instantaneous current at time nT
 m is the number of samples

The meter calculates the energy sum while the load current is greater than the starting current. When the accumulated value reaches the energy defined by the meter constant K_h , expressed in watt-hours/impulse, the meter emits one energy pulse, increments the billable energy accumulation in its memory, and resets and restarts the energy accumulation.

RMS Current Calculation

The RMS current measurement is not used for calculating energy consumption, but may be used for diagnostic purposes and for display. The RMS current is generally calculated over a fixed number of samples. The RMS current over time nT can be calculated

$$I_{RMS} = \sqrt{\frac{\sum_{k=0}^{n-1} i(kt)^2}{n}}$$

Where, $i(kt)$ is the instantaneous current at time kt .

Current Accuracy v. Energy Accuracy

The function of the energy meter is to measure the energy delivered, while the current measurement provides auxiliary information. Accuracy in the energy measurement and accuracy in current measurement are not unrelated. There are three error sources in the current sensor that can contribute to current and energy measurement: offset error, noise, and nonlinearity.

Offset

Offset is a DC error, and is a non-zero DC output of the sensor when the input signal is zero. For current measurement in energy meters offset error should not be a concern unless it exceeds the input offset voltage of a differential input ADC, or uses a significant portion of the range of a single-ended input ADC, since offset from sensors or ADC are removed in the meter signal processing.

Noise

All sensors contribute some noise to their output signals. This noise will affect the RMS current measurement unless it can be filtered out either by analog or digital signal processing. The noise which is most difficult to eliminate is flicker noise, or $1/f$ noise. The power spectral density of $1/f$ noise is inversely proportional to frequency. Flicker noise is the dominant noise in TMR sensors, and will affect the RMS current measurement at low currents. The most effective way of reducing the effect of $1/f$ noise contribution from TMR sensors is to increase the signal level by increasing the flux density at the sensors for the same current, either by decreasing the distance between the sensor and the conductor, or by using magnetic concentrators.

Fortunately, the energy calculation of Equation 3 filters out components of the current measurement that are not at the same frequency and phase as the voltage signal, and that is zero-mean over the summation period. This keeps the $1/f$ noise from making a significant contribution to energy measurement error.

Nonlinearity

The largest source of current and energy measurement error from TMR sensors is non-linearity, the degree to which the output of the sensor circuit differs from a linear relationship of . Some nonlinearity is inherent in the sensors, but nonlinearity can be minimized in the system implementation, which will be discussed next.

Design Example with CTD205 Current Sensor Demo Board

The CTD205 Current Sensor board provides a flexible platform for evaluating the performance of Crocus's magnetic sensors in energy metering applications up to 110A.

Key features

- IMAX (with concentrator) $\leq 110A$
- Nonlinearity better than $\pm 0.5\%$
- Power supply $5.25V \leq V_{IN} \leq 13.2V$
- External output reference
- Easily adjustable output gain

The CTD205 Current Sensing Demonstration board is an example of the half-bridge closed loop implementation earlier described in section 5 with modifications to extend the usable range and reduce non-linearity.

The CTD205 was designed so that it could be interfaced to a wide variety of metering system on chip (SOC) or analog front-end (AFE) devices, so it supports different

The schematic for the CTD205 is shown in Figures 5, 5.1, and 6 on the next pages.

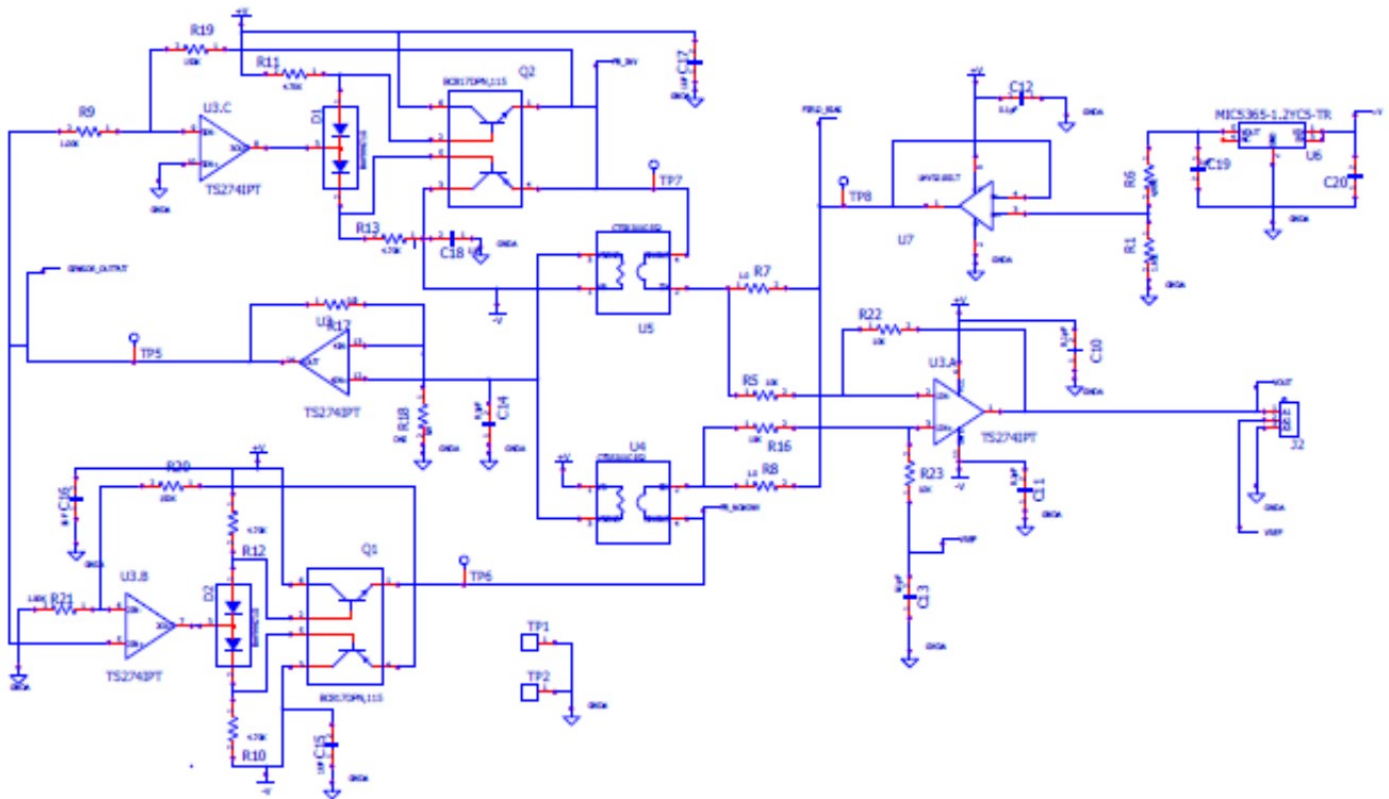

Figure 5: CTD205 Schematic

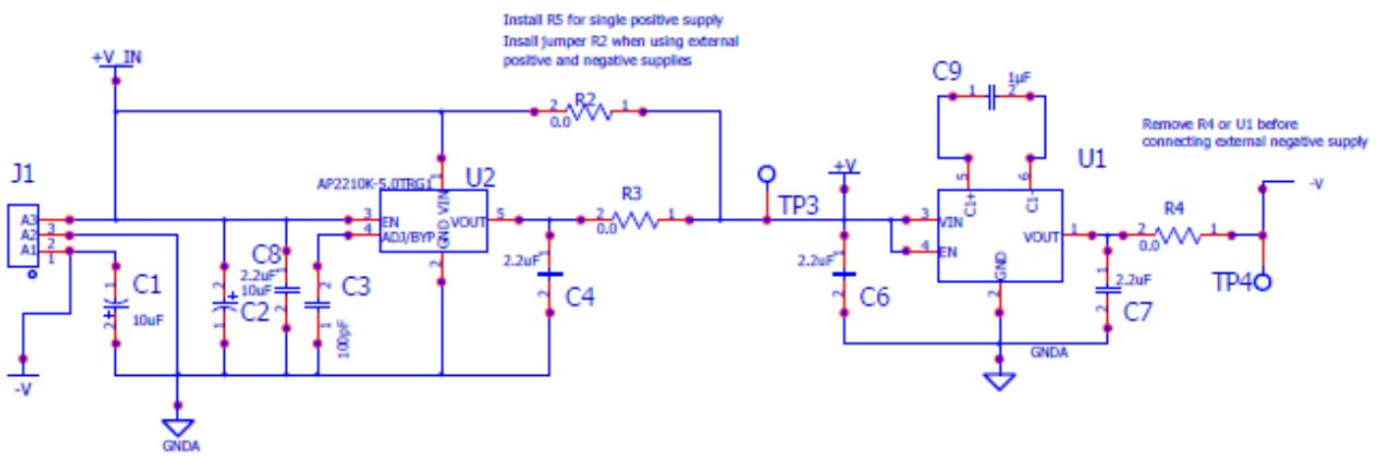

Figure 6: CTD205 Schematic (Continued)

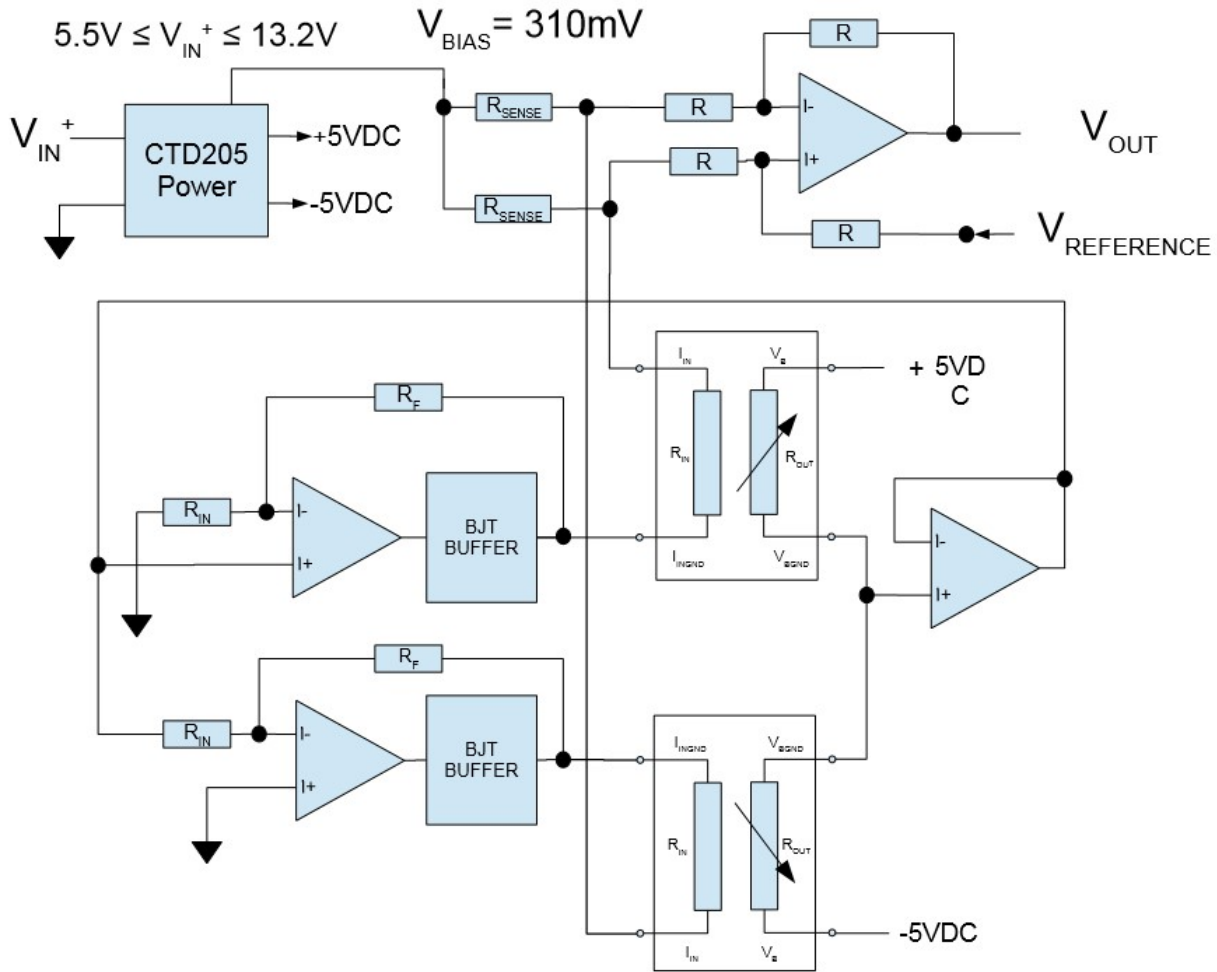

Figure 5.1: CTD205 Block Diagram

Power

The CTD205 can be powered from an unregulated DC supply of 5.2V to 13.2V. On board, the input supply is regulated to +V by LDO regulator U2. A capacitive voltage inverter, U1 generates a -5V supply from the regulated +5V. The negative supply is needed to allow the board output to be referenced to ground to support metering ICs with ground-referenced ADC inputs. It also provides a wider voltage range for the feedback circuits. A meter designed to use the magnetic sensors would not require this supply, as the sensor circuits could be powered from the board's off-line power supply.

Sensors and Feedback Circuits

Two CTSR218 sensors, U4 and U5 form the sensor half-bridge. The ends of the half-bridge formed by the sense resistors are connected to the +V and -V power rails, so that when not magnetic field is applied, the bridge output is at or near 0V. The field line bias is provided by op amp U7, configured as a voltage follower and driven from a 310mV voltage reference formed by 1.2V LDO regulator U6 and the voltage divider of R1 and R6. This approach was taken to make the bias voltage independent of the board supply voltage. The 310mV bias drives 10mA into the 30Ω field lines of U4 and U5 and the 1Ω sense resistors which are connected in series with them. The bridge output is buffered by U3D. This amplifier is normally configured as a voltage follower, and is provided so that the bridge voltage is not affected by driving the feedback circuits. Resistor positions are provided to allow gain to be added to the buffer if desired.

Amplifiers U3B and U3C provide the non-inverting and inverting feedback respectively. When the bridge output voltage rises due to an external magnetic field, U3B drives the FB_NONINV voltage toward V+. This changes the field line current to lower U4's sense resistor and reduce the bridge output voltage.

At the same time, U3C drives the FB_INV voltage toward V-. This changes the current in U5's field line to decrease U4's sense resistor and reduce the bridge output voltage.

When the bridge voltage returns to 0V, the feedback circuits maintain the field line currents necessary to keep the bridge in balance.

Output Stage

When the bridge is balanced, the difference in the field line currents and the bias currents are proportional to the strength of the external magnetic field.

The differential output amplifier implemented with U3A amplifies the voltage difference between the current sense resistors R7 and R8 and provides an output voltage proportional to the external magnetic field. When no external magnetic field is present only the bias current flows in the field lines and the current sense resistors. The voltage drop across each sense resistor is the same so the differential voltage provided to U3A is zero. When an external field is present the currents are unequal, and the current sense resistor voltage drops and the output voltage are proportional to the external field

The output voltage is referenced to the externally provide VREF voltage. This allows the output of the current sensor board to drive directly metering chips ADCs that may use 3.3V, ground, or VDD/2 as their input references.

The gain of U3A can be increased by changing R22 and R23. With unity gain for the output amplifier and with the ferrite toroid magnetic concentrator provided with the board the current sensitivity of the board is $\approx 750\mu\text{V/A}$.

Design Considerations with Crocus MLU Sensors

Feedback Amplifiers—Drive Capability

The field line drive circuit must be able to drive the 31Ω load presented by the field lines and current sense resistors, and should have symmetrical drive capability, that is they must be able to sink and source the same current magnitude. Most general purpose op amps do not meet these requirements. In order to solve that problem the feedback op amps drive a class AB or push-pull output stage with sufficient current drive. The minimum hFE of the BC817DPN complementary BJT pair used on the CTD205 is 160, so the op amp outputs see at least a 4960Ω load. Their 500mA current drive capability is much greater than required. The selection of the BJTs is not critical. Any small signal or general purpose complementary pair could be used as long as their hFEs are fairly well matched and >100 .

The series diodes and $4.7k\Omega$ resistors used are needed to eliminate crossover distortion in the class AB output stage. By keeping the base of the NPN one diode drop above the op amp output, and the base of the PNP one diode drop below the op amp output, they ensure that when the signal is near zero one transistor always starts to conduct before the other reaches cutoff. For the BAV99 and the BC817DPN, diode forward current around $900\mu A$ is sufficient. The diode forward voltage should not be high enough to turn both BJTs fully on when the diode common terminal is near ground, as this will short both $V+$ and $V-$ to ground.

Using audio amplifiers designed to drive 16Ω or 32Ω headphones could also be feasible. These would reduce part count and board space.

Feedback Amplifiers—Feedback Gain

The bridge is balanced by the field line current. The feedback gain should be large enough to drive sufficient field line current to balance the bridge at the maximum current to be measured. Beyond that the feedback gain does not have a direct effect on the output voltage. For example, if 20mA field line current is required to cancel the maximum expected external magnetic field, and feedback gain of 50 is sufficient to provide that, increasing the feedback gain to 100 will not double the board's output voltage. In practice, feedback gain in the range of 50 to 150 has been shown to work well. Increasing gain to 200 has been seen to cause problems of oscillation.

Bias Current Supply

With the CTSR218, biasing the field lines with $\sim 10mA$ from I_{IN} to I_{INGD} biases the sensors to within the most nearly linear region of their BR transfer curve. A bias supply comprising a voltage regulator, voltage divider, and voltage follower was implemented on the CTD205 to make the bias current independent of feedback gain and power supply voltages. In a custom design for use with known and fixed power supply voltage and feedback gain, it would be reasonable to bias the quiescent output of the feedback amplifier to provide the quiescent bias current.

Temperature Effect on Sensor

The CTSR218 sensors are sensitive to temperature. The half-bridge implementation has been demonstrated to provide good temperature compensation. The temperature coefficients of resistance in the sensors are closely matched so that resistance of each sensor rises and falls together, which does not affect the bridge output voltage. The sensitivity is not significantly affected by temperature.

Temperature Effect on Field Lines

The field lines are copper traces on the sensor die. Copper has a rather large temperature coefficient of resistance of $\approx 0.39\%/^{\circ}\text{C}$. If the field line temperature drops from 25°C to -40°C , the field line resistance drops by 2.54%. If the field line temperature increases from 25°C to 85°C , the field line resistance increases by 2.34%. In the closed loop half-bridge implantation this resistance change does not affect the field line current required to keep the bridge balanced, but the voltage required to drive the current is directly affected by the field line resistance change. If the voltage across the field lines is used as a measure of current, the measurements will not be stable over temperature, and even without any ambient temperature change, the power dissipated in the field lines will cause self-heating of the sensor. Using external current sense resistors, as implemented in the CTD205, will eliminate the effect of resistance change in the field lines. Selection of the current sensing resistors is a system design issue. Higher resistance will provide higher output voltage for better signal/noise ratio, but resistance that approaches the nominal 30Ω resistance of the field lines will limit the current measurement range.

Magnetic Concentrators

A magnetic concentrator is a device to concentrate and focus magnetic flux. Using magnetic concentrators with TMR sensors in current sensing applications offers significant advantages compared to using the sensors simply placed in proximity to a conductor.

A main benefit to use of flux concentrators is that they can increase the flux density seen by a magnetic sensor due to current flowing in a conductor. This increases the signal level at low currents which improves the SNR. Figure 7 shows the effect of using a magnetic concentrator. The left picture shows the magnetic flux density along the x axis around a 6mm diameter conductor carrying 141.41A current (peak current for 100ARMS). The right picture shows the flux around the conductor when a 25.3mm ferrite toroid with an 8mm air gap is placed around the conductor. The smaller of the two rectangles toward the bottom of the plot represents a magnetic sensor 12.8mm from the surface of the conductor. The sensor is now just outside of the air gap. This is the geometry of the concentrator that is used with the CTD205 board. The simulation results show that the ferrite toroid concentrator provides 4.7x increase in flux density along the sensors' axes of sensitivity, from 2.1mT to 9.8mT

Magnetic concentrators can also provide shielding from stray magnetic fields from adjacent conductors or from intentional tampering. More testing is needed to determine the most appropriate shielding materials and forms.

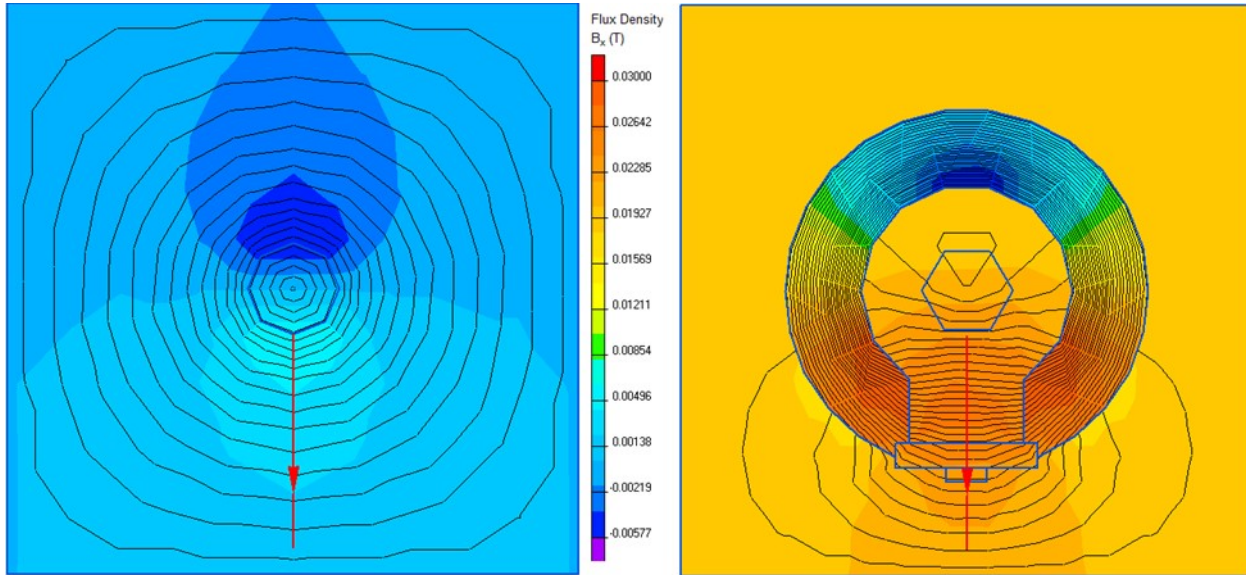

Figure 5: Effect of Ferrite Toroid Concentrator

CTD205 Performance

Figure 8 shows the current measurement performance over the range 0.5A to 110A for 5 units of CTD205. The tests were performed using a Maxim Integrated Products DB6543 polyphase demonstration board. Current channel A was left in the original configuration, using the CR Magnetics CR8459-2000-N with which the board was designed to work. The burden resistors were removed for current channel B, and the CTD205 VOUT was connected to the current channel B positive input (IBP_IN). The DB6543's +3.3VDC rail (V3P3) was connected to the CTD205 VREF and to the DB6543 current channel B negative input, connecting it as a single-ended input. The RMS current measurement from channel IA was used as the reference meter to which the channel IB RMS current measurement with the CTD205 was compared. The vertical axis of Figure 8 shows the difference in the CTD205 channel measurement and the current transformer channel measurement as a percentage of the current channel measurement.

Additional testing will be performed to determine the energy linearity of the meter equipped with Crocus sensor boards replacing the original current sensors. This report will be updated when those results are available.

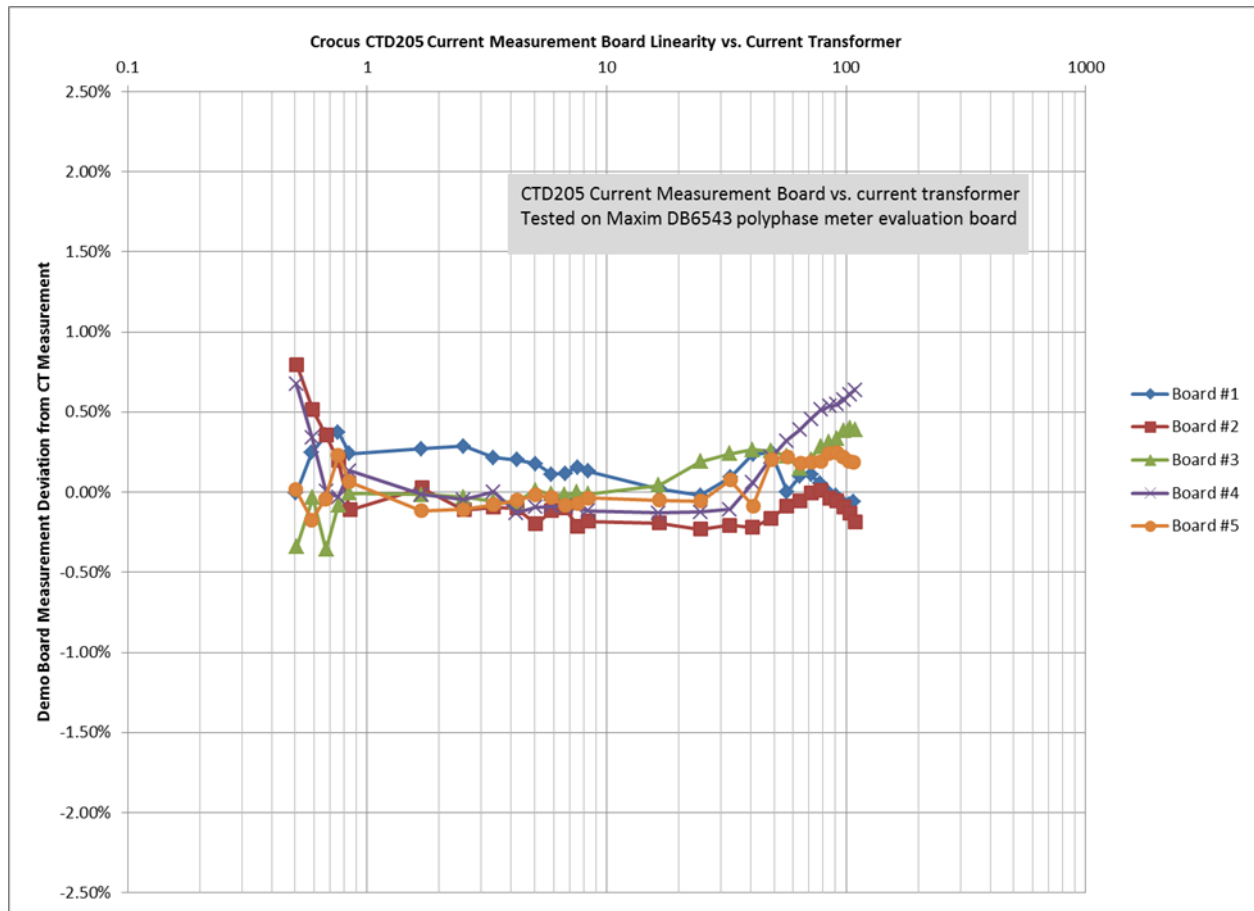

Figure 8: CTD205 Current Measurement Performance v. Current Transformer

External Influence Factors

In addition to energy linearity requirements, meter standards also specify the required immunity to a number of influence factors. These are all system level specifications, but some influence factors such as temperature and stray magnetic fields can affect sensor performance.

Temperature

Initial tests show that with the temperature compensation provided by the half-bridge sensor configuration used in the CTD205 board ambient temperature does not significantly affect the sensitivity or linearity of the sensor circuit. More extensive testing should be done to validate these results, and this report updated when the test results are available.

Stray Magnetic Fields

Magnetic sensors used for current measurement in an energy meter will be subjected to magnetic fields in addition to those generated by the conductors in which current is to be measured. These will include fields from adjacent conductors in the meter itself, from external conductors and electrical equipment, and from intentional tampering. These issues must be addressed with shielding and with sensor placement and orientation. Additional investigation should be done on these effects.

Disclaimer: The contents of this document are provided in connection with products of Crocus Technology (Crocus). CROCUS MAKES NO REPRESENTATIONS OR WARRANTY OF ANY KIND, EXPRESS OR IMPLIED, WITH RESPECT TO THE ACCURACY OR COMPLETENESS OF THE CONTENTS HEREIN, INCLUDING, BUT NOT LIMITED TO, THE IMPLIED WARRANTIES OF MERCHANTABILITY AND FITNESS FOR A PARTICULAR PURPOSE AND RESERVES THE RIGHT TO MAKE CHANGES TO THE SPECIFICATIONS AND PRODUCT DESCRIPTIONS AT ANY TIME WITHOUT NOTICE. Crocus reserves the right to discontinue or make changes to its products at any time without notice. Crocus's products have not been designed, tested, or manufactured for use and should not be used in applications where the failure, malfunction or inaccuracy of the Products carries a risk of death or serious bodily injury or damage to tangible property, including, but not limited to, life support systems, nuclear facilities, military, aircraft navigation or communication, emergency systems, harsh environments, or other applications with a similar degree of potential hazard.

ATTRIBUTION

© 2016 Crocus Technology, Inc. and Crocus Technology SA. All rights reserved. Crocus Technology, Blossoming Future, MLU, and combinations thereof are trademarks of Crocus Technology, Inc. and Crocus Technology SA.



Стандарт Электрон Связь

Мы молодая и активно развивающаяся компания в области поставок электронных компонентов. Мы поставляем электронные компоненты отечественного и импортного производства напрямую от производителей и с крупнейших складов мира.

Благодаря сотрудничеству с мировыми поставщиками мы осуществляем комплексные и плановые поставки широчайшего спектра электронных компонентов.

Собственная эффективная логистика и склад в обеспечивает надежную поставку продукции в точно указанные сроки по всей России.

Мы осуществляем техническую поддержку нашим клиентам и предпродажную проверку качества продукции. На все поставляемые продукты мы предоставляем гарантию .

Осуществляем поставки продукции под контролем ВП МО РФ на предприятия военно-промышленного комплекса России , а также работаем в рамках 275 ФЗ с открытием отдельных счетов в уполномоченном банке. Система менеджмента качества компании соответствует требованиям ГОСТ ISO 9001.

Минимальные сроки поставки, гибкие цены, неограниченный ассортимент и индивидуальный подход к клиентам являются основой для выстраивания долгосрочного и эффективного сотрудничества с предприятиями радиоэлектронной промышленности, предприятиями ВПК и научно-исследовательскими институтами России.

С нами вы становитесь еще успешнее!

Наши контакты:

Телефон: +7 812 627 14 35

Электронная почта: sales@st-electron.ru

Адрес: 198099, Санкт-Петербург,
Промышленная ул, дом № 19, литера Н,
помещение 100-Н Офис 331