

## High Voltage EL Lamp Driver

### Features

- ▶ 1.8V to 6.5V operating supply voltage
- ▶ DC to AC conversion
- ▶ Separately adjustable lamp and converter frequency
- ▶ Output voltage regulation
- ▶ Enable/disable function
- ▶ Patented output timing for high efficiency
- ▶ <100nA shutdown current
- ▶ Split supply capability
- ▶ LCD backlighting

### Applications

- ▶ Portable Transceivers
- ▶ Remote Control Units
- ▶ Calculators
- ▶ PDAs
- ▶ Global Positioning Systems (GPS)

### General Description

The Supertex HV833 is a high voltage driver designed for driving EL lamps of up to 35nF (10-12in<sup>2</sup>). The input supply voltage range is from 1.8V to 6.5V. The device uses a single inductor and a minimum number of passive components. The nominal regulated output voltage that is applied to the EL lamp is  $\pm 90V$ . The chip can be enabled/disabled by connecting a resistor between the  $R_{SW-Osc}$  pin and the  $V_{DD}/GND$  pins.

The HV833 has two internal oscillators, a switching MOSFET, and a high voltage EL lamp driver. The frequency for the switching MOSFET is set by an external resistor connected between the  $R_{SW-Osc}$  pin and the  $V_{DD}$  supply pin. The EL lamp driver frequency is set by an external resistor connected between the  $R_{EL-Osc}$  pin and the  $V_{DD}$  pin. An external inductor is connected between the  $L_X$  pin and  $V_{DD}$  or  $V_{IN}$  pin. A 0.003-0.1 $\mu F$  capacitor is connected between the  $C_S$  pin and the GND pin. The EL lamp is connected between the  $V_A$  pin and the  $V_B$  pin.

The switching MOSFET charges the external inductor and discharges it into the capacitor at  $C_S$ . The voltage at  $C_S$  will start to increase. Once the voltage at  $C_S$  reaches a nominal value of 90V, the switching MOSFET is turned OFF to conserve power. The outputs  $V_A$  and  $V_B$  are configured as an H bridge and are switching in opposite states to achieve 180V peak-to-peak across the EL lamp.

### Typical Application Circuit

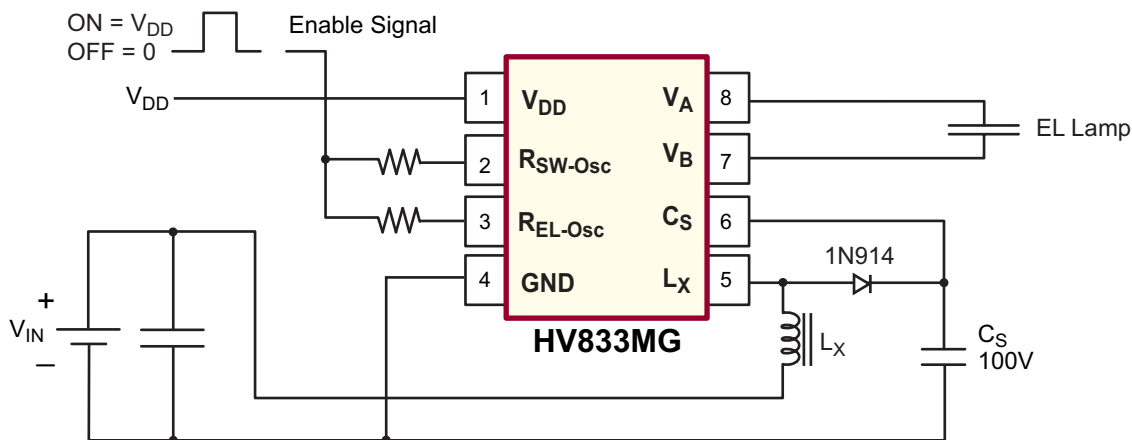

## Ordering Information

Device	Package Options	
	MSOP-8 <sup>1</sup>	
HV833	HV833MG	HV833MG-G

<sup>1</sup>-G indicates package is RoHS compliant ("Green")



## Absolute Maximum Ratings

Parameter	Value
Supply voltage $V_{DD}$	-0.5V to 7.5V
Output voltage, $V_{CS}$	-0.5V to 125V
Operating Temperature	-40°C to +85°C
Storage Temperature	-65°C to +150°C
MSOP-8 Power Dissipation	300mW

Absolute Maximum Ratings are those values beyond which damage to the device may occur. Functional operation under these conditions is not implied. Continuous operation of the device at the absolute rating level may affect device reliability. All voltages are referenced to device ground.

## Pin Configuration

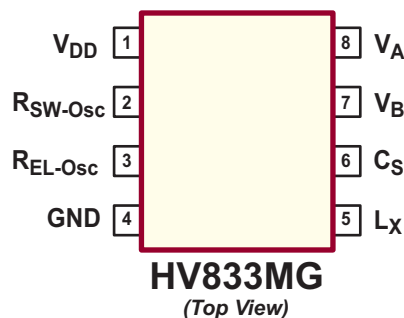

## Recommended Operating Conditions

Symbol	Parameter	Min	Typ	Max	Units	Conditions
$V_{DD}$	Supply voltage	1.8	-	6.5	V	---
$f_{EL}$	$V_{A-B}$ output drive frequency	60	-	1000	Hz	---
$T_A$	Operating Temperature	-25	-	+85	°C	---

## DC Electrical Characteristics (Over recommended operating conditions unless otherwise specified, $T_A=25^\circ\text{C}$ )

Symbol	Parameter	Min	Typ	Max	Units	Conditions
$R_{DS(ON)}$	On-resistance of switching transistor	-	-	4.0	$\Omega$	$I = 100\text{mA}$
$V_{CS}$	Max. output regulation voltage	80	90	100	V	$V_{DD} = 1.8\text{V to } 6.5\text{V}$
$V_{A-B}$	Max differential output voltage across lamp	160	180	200	V	$V_{DD} = 1.8\text{V to } 6.5\text{V}$
$I_{DDQ}$	Quiescent $V_{DD}$ supply current	-	-	100	nA	$R_{SW-Osc} = \text{Low}$
$I_{DD}$	Input current going into the $V_{DD}$ pin	-	-	150	$\mu\text{A}$	$V_{DD} = 1.8\text{V to } 6.5\text{V}$ . See Figure 1.
$I_{IN}$	Input current including inductor current	-	56	64	mA	$V_{IN} = 3.3\text{V}$ . See Figure 1.
$V_{CS}$	Output voltage on $V_{CS}$	63	72	81	V	$V_{IN} = 3.3\text{V}$ . See Figure 1.
$f_{EL}$	$V_{DIFF}$ output drive frequency	240	270	300	Hz	$V_{IN} = 3.3\text{V}$ . See Figure 1.
$F_{SW}$	Switching transistor frequency	55	65	75	kHz	$V_{IN} = 3.3\text{V}$ . See Figure 1.
D	Switching transistor duty cycle	-	88	-	%	See Figure 1.

## Enable/Disable Function Table

Symbol	Parameter	Min	Typ	Max	Units	Conditions
EN-L	Logic input low voltage	0	-	0.5	V	$V_{DD} = 1.8\text{V to } 6.5\text{V}$
EN-H	Logic input high voltage	$V_{DD} - 0.5$	-	$V_{DD}$	V	$V_{DD} = 1.8\text{V to } 6.5\text{V}$

### Functional Block Diagram

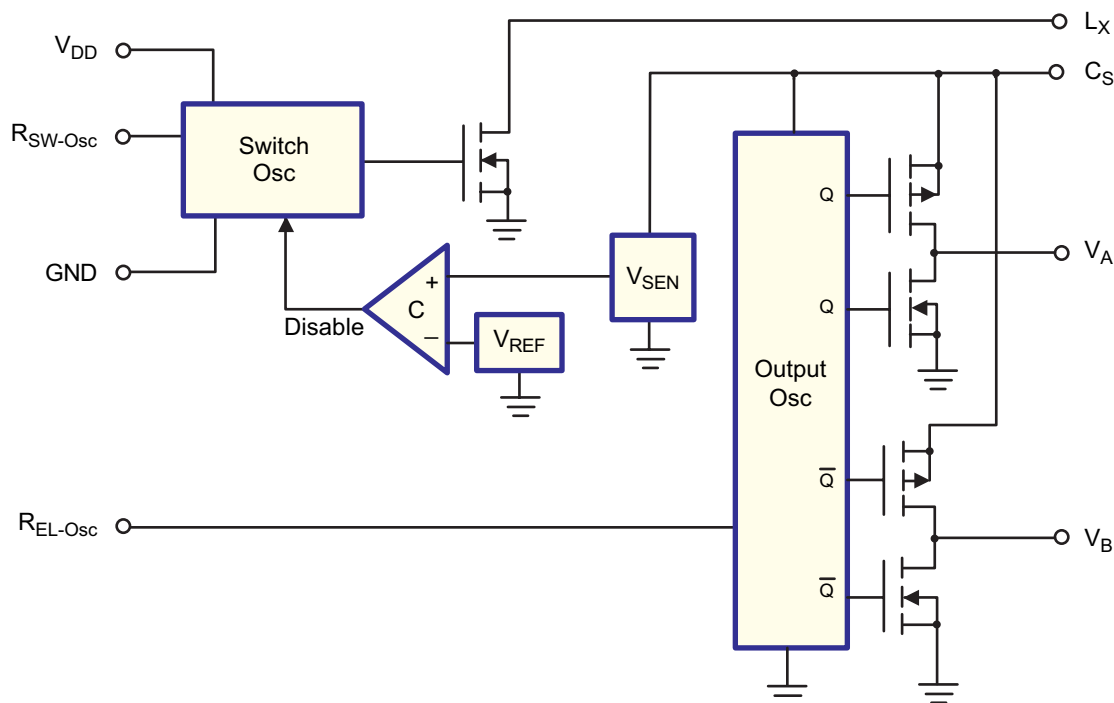
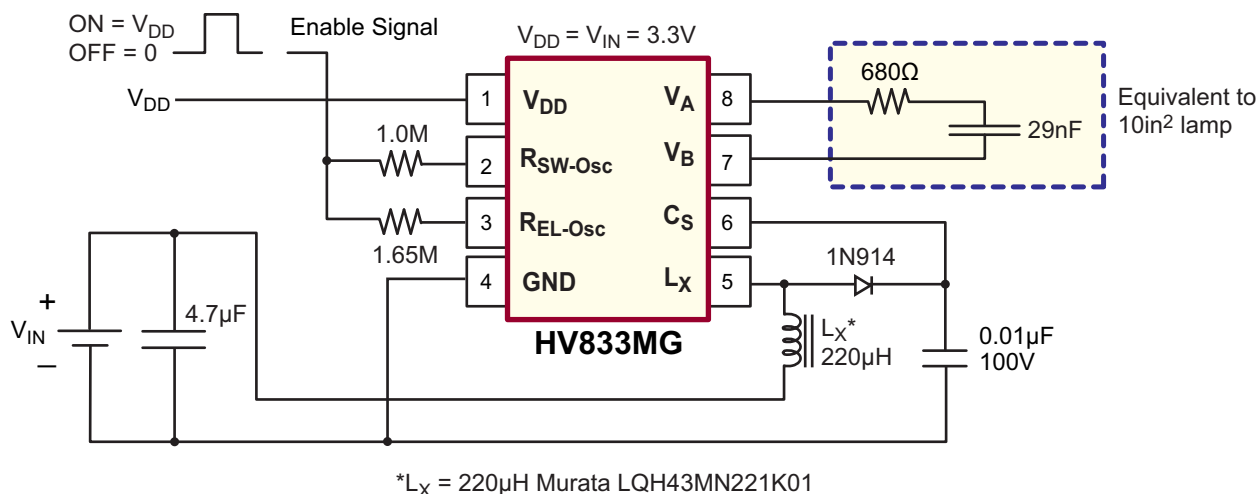

Fig. 1: Typical Application/Test Circuit



### Typical Performance

Device	Lamp Size	V <sub>IN</sub>	I <sub>IN</sub>	V <sub>CS</sub>	f <sub>EL</sub>	Brightness	T <sub>A</sub>
HV833MG	10in <sup>2</sup>	3.3V	56mA	72V	270Hz	5.0ft-lm	-25°C to + 85°C

Typical Performance Curves for Fig. 1 (EL Lamp = 10.0in<sup>2</sup>, V<sub>IN</sub> = V<sub>DD</sub>)

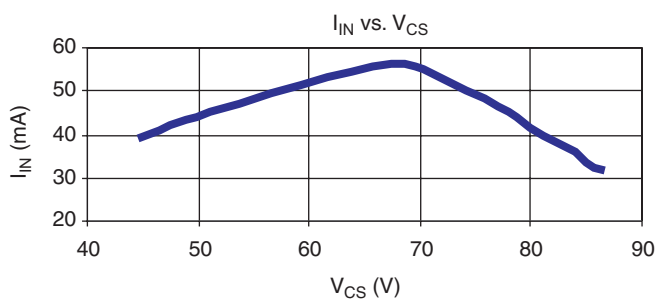
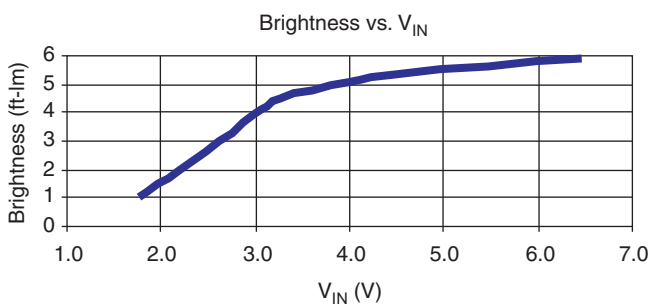
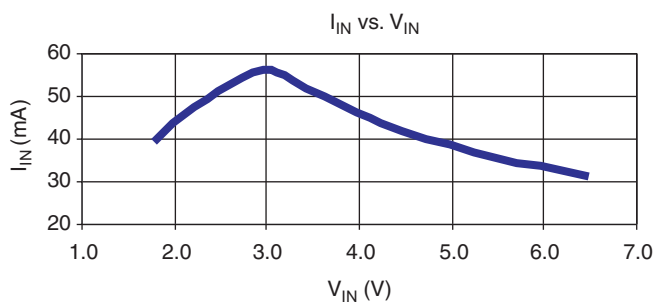
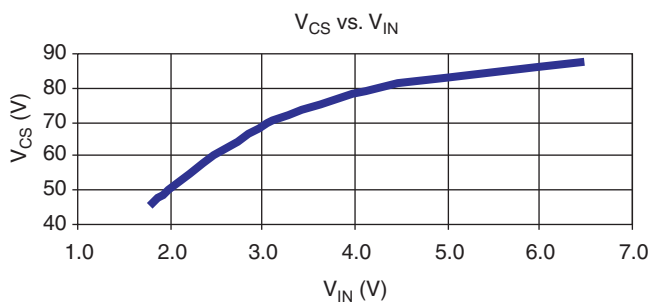
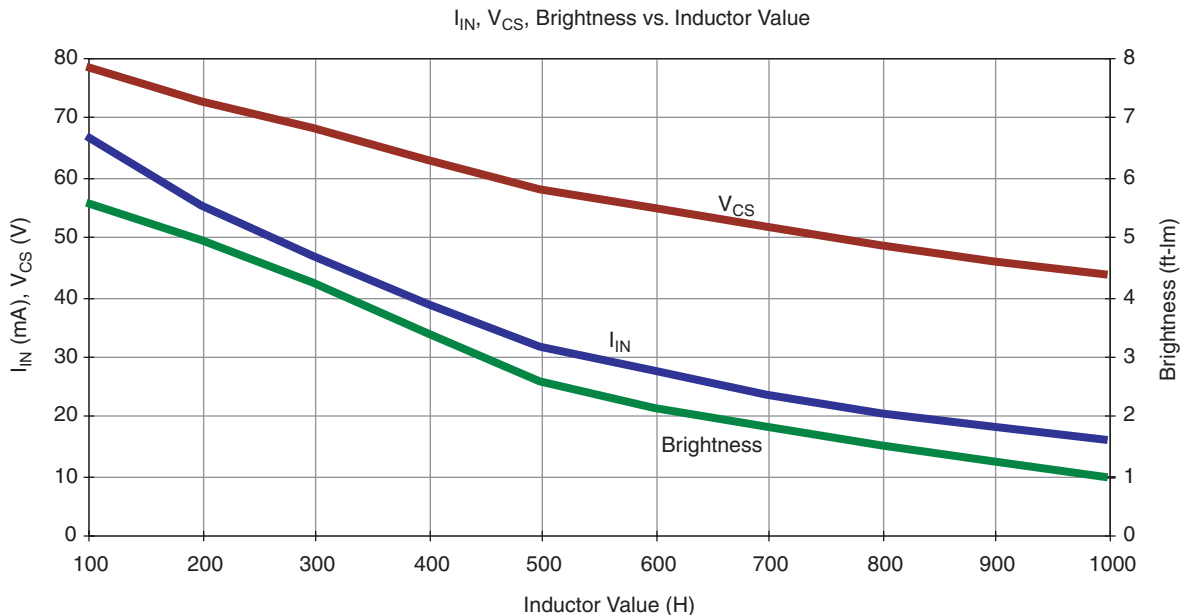

## Fig. 2: Typical Application

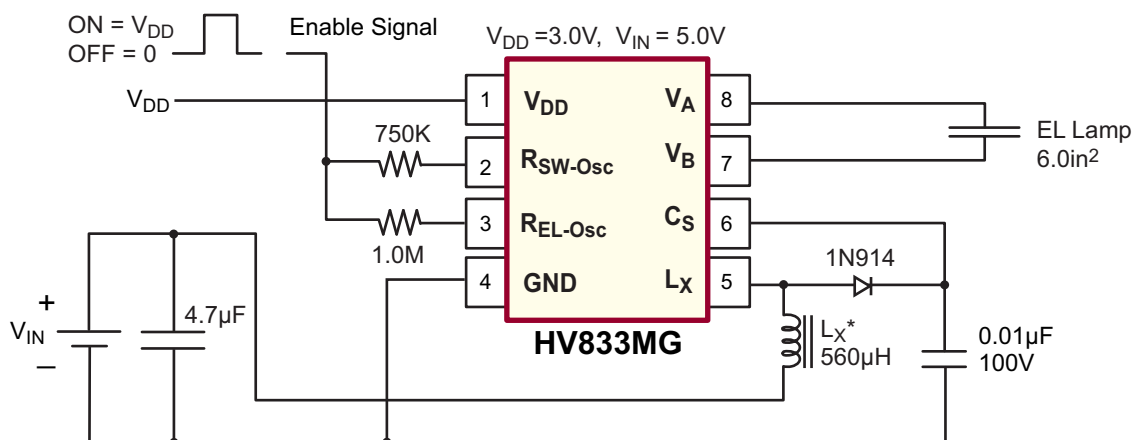

\* $L_X = 560\mu H$  Murata LQH43MN561K01

## Typical Performance

Device	Lamp Size	$V_{IN}$	$I_{IN}$	$V_{CS}$	$f_{EL}$	Brightness	$T_A$
HV833MG	6.0in <sup>2</sup>	5.0V	30mA	70V	440Hz	6.0ft-Im	-25°C to + 85°C

Typical Performance Curves for Fig. 2 ( $EL\ Lamp = 6.0in^2, V_{DD} = 3.0, V_{IN} = 5.0V$ )

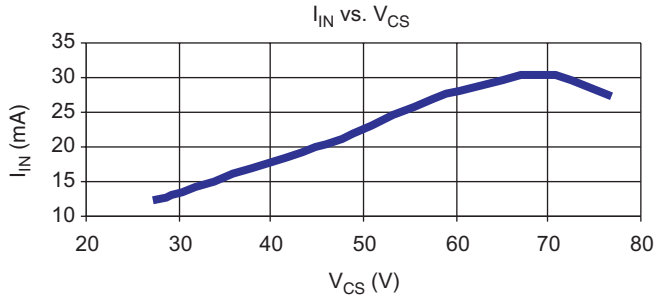
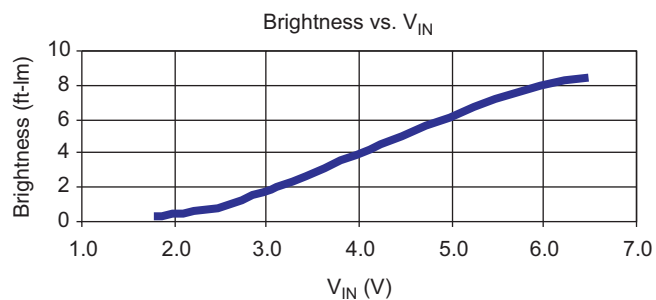
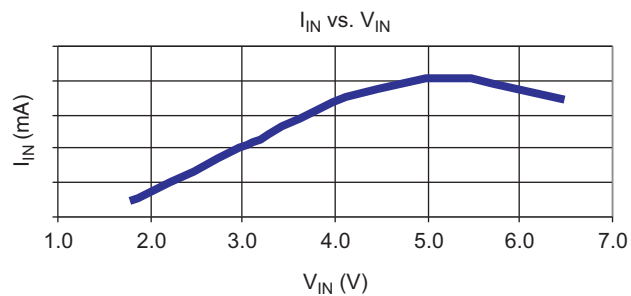
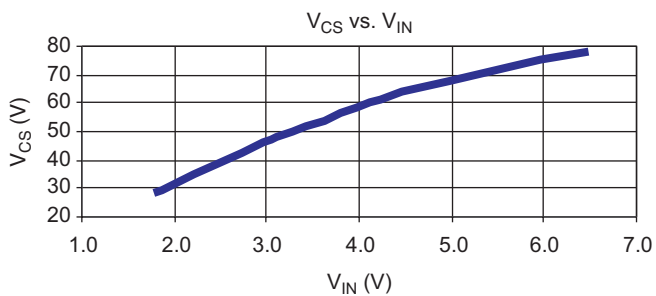
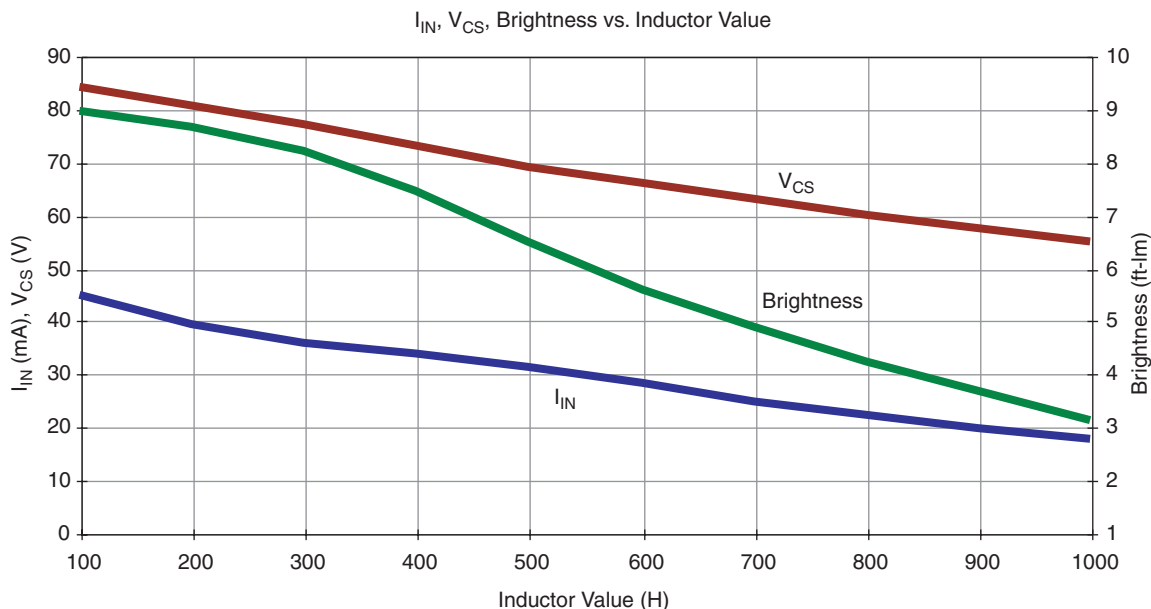
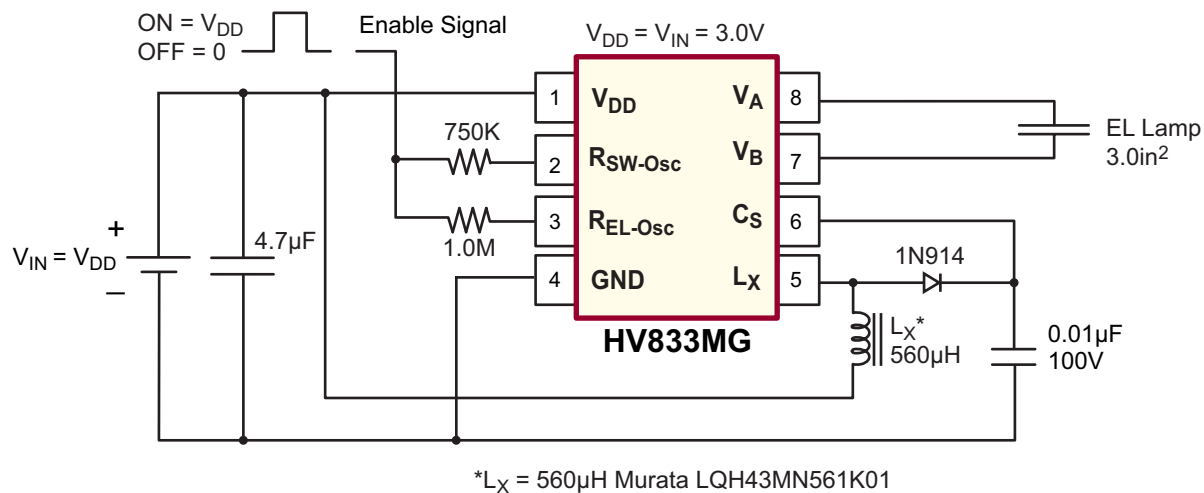

Fig. 3: Typical Application



Typical Performance

Device	Lamp Size	V <sub>IN</sub>	I <sub>IN</sub>	V <sub>CS</sub>	f <sub>EL</sub>	Brightness	T <sub>A</sub>
HV833MG	3.0in <sup>2</sup>	3.0V	20mA	60V	440Hz	4.0ft-Im	-25°C to + 85°C

Typical Performance Curves for Fig. 3 (EL Lamp = 3.0in<sup>2</sup>, V<sub>IN</sub> = V<sub>DD</sub>)

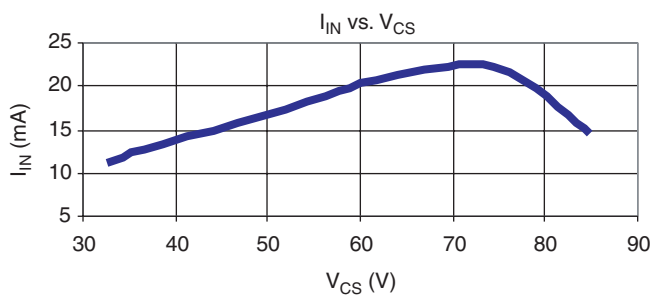
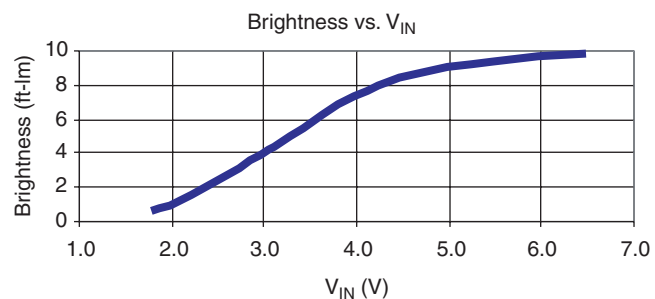
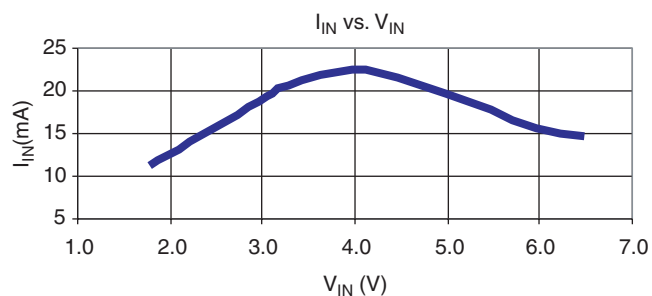
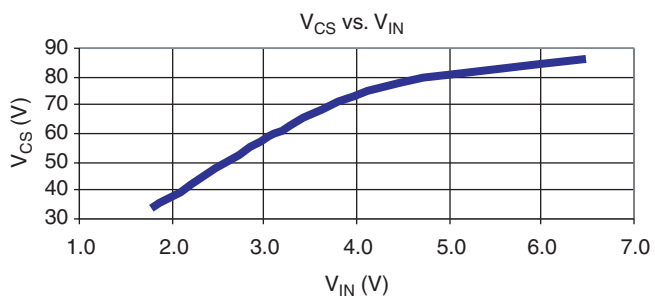
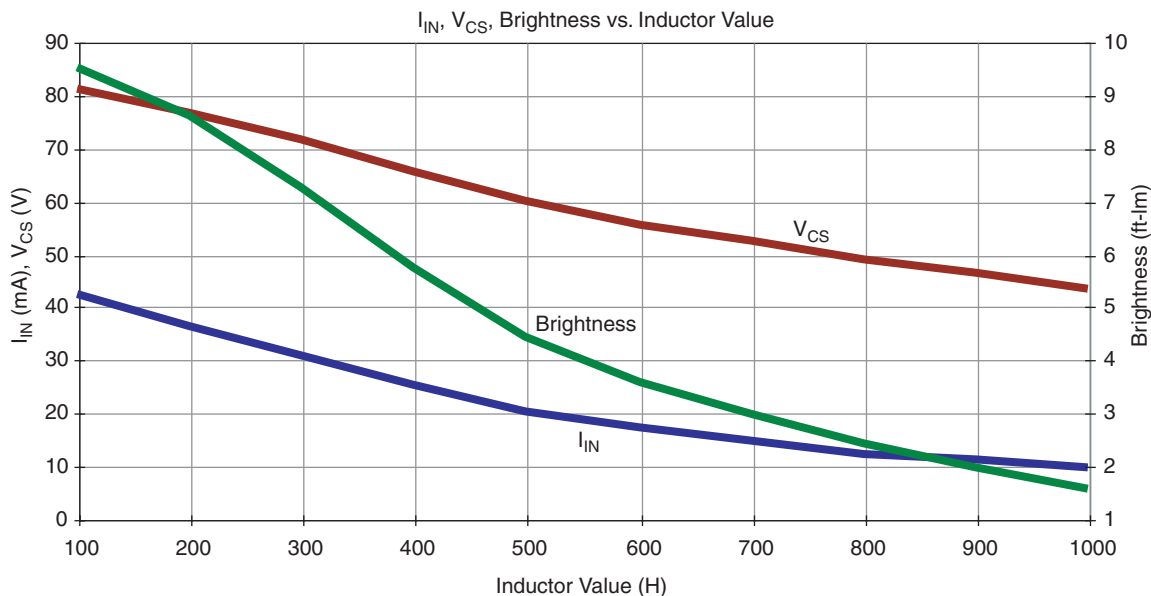



## Enable/Disable Configuration

The HV833 can be easily enabled and disabled via a logic control signal on the  $R_{SW}$  and  $R_{EL}$  resistors as shown in the Typical Application Circuit on the front page. The control signal can be from a microprocessor.  $R_{SW}$  and  $R_{EL}$  are typically

very high values. Therefore, only 10's of microamperes will be drawn from the logic signal when it is at a logic high (enable) state. When the microprocessor signal is high the device is enabled and when the signal is low, it is disabled.

## Enable/Disable Table

Enable Signal	HV833
$V_{DD}$	Enable
0V	Disable

## Split Supply Configuration for Battery Voltages of Higher than 6.5V

The Typical Application Circuit on the first page can also be used with high battery voltages such as 12V as long as the input voltage,  $V_{DD}$ , to the HV833 device is within its specifications of 1.8V to 6.5V. Split supply configuration is shown on Fig. 2.

## External Component Description

External Component	Selection Guide Line
Diode	Fast reverse recovery diode, 100V 1N4148 or equivalent.
$C_s$ Capacitor	0.003 $\mu$ F to 0.1 $\mu$ F, 100V capacitor to GND is used to store the energy transferred from the inductor.
$R_{EL-Osc}$	The EL lamp frequency is controlled via an external $R_{EL}$ resistor connected between $R_{EL-Osc}$ and $V_{DD}$ pins of the device. The lamp frequency increases as $R_{EL}$ decreases. As the EL lamp frequency increases, the amount of current drawn from the battery will increase and the output voltage $V_{CS}$ will decrease. The color of the EL lamp is dependent upon its frequency.
$R_{SW-Osc}$	The switching frequency of the converter is controlled via an external resistor, $R_{SW}$ between $R_{SW-Osc}$ and $V_{DD}$ pins of the device. The switching frequency increases as $R_{SW}$ decreases. With a given inductor, as the switching frequency increases, the amount of current drawn from the battery will decrease and the output voltage, $V_{CS}$ , will also decrease.
$L_x$ Inductor	The inductor $L_x$ is used to boost the low input voltage by inductive flyback. When the internal switch is on, the inductor is being charged. When the internal switch is off, the charge stored in the inductor will be transferred to the high voltage capacitor $C_s$ . The energy stored in the capacitor is connected to the internal H-bridge, and therefore to the EL lamp. In general, smaller value inductors, which can handle more current, are more suitable to drive larger size lamps. As the inductor value decreases, the switching frequency of the inductor (controlled by $R_{SW}$ ) should be increased to avoid saturation.  A 220 $\mu$ H Murata (LQH43MN221) inductor with 5.4 $\Omega$ series DC resistance is typically recommended. For inductors with the same inductance value but with lower series DC resistance, a lower $R_{SW}$ value is needed to prevent high current draw and inductor saturation.
Lamp	As the EL lamp size increases, more current will be drawn from the battery to maintain high voltage across the EL lamp. The input power, ( $V_{IN} \times I_{IN}$ ), will also increase. If the input power is greater than the power dissipation of the package (300mW), an external resistor in series with one side of the lamp is recommended to help reduce the package power dissipation.

# 8-Lead MSOP Package Outline (MG)

3x3mm body, 1.10mm height (max), 0.65mm pitch

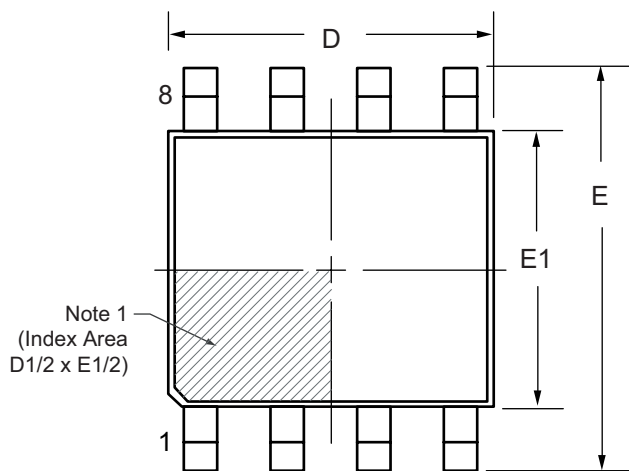

**Top View**

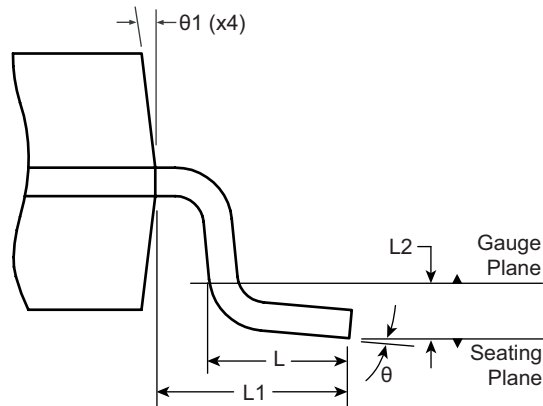

**View B**

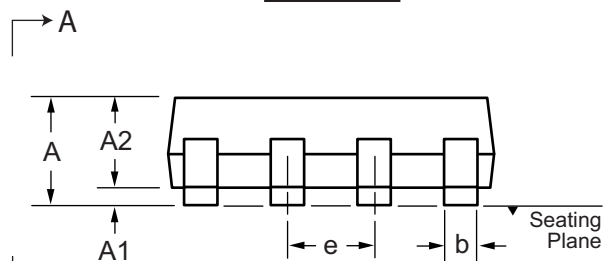

**Side View**

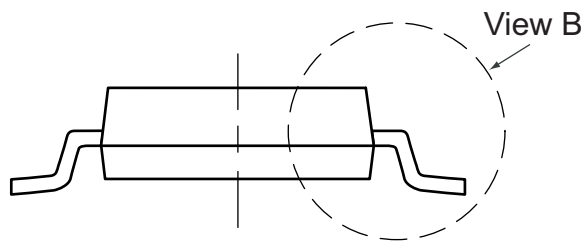

**View A-A**

**Note 1:**

A Pin 1 identifier must be located in the index area indicated. The Pin 1 identifier may be either a mold, or an embedded metal or marked feature.

Symbol		A	A1	A2	b	D	E	E1	e	L	L1	L2	θ	θ1
Dimension (mm)	MIN	0.75	0.00	0.75	0.22	2.80	4.65	2.80	0.65 BSC	0.40	0.95 REF	0.25 BSC	0°	5°
	NOM	-	-	0.85	-	3.00	4.90	3.00		0.60			-	-
	MAX	1.10	0.15	0.95	0.38	3.20	5.15	3.20		0.80			8°	15°

JEDEC Registration MO-187, Variation AA, Issue E, Dec. 2004.

Drawings not to scale.

**Supertex inc.** does not recommend the use of its products in life support applications, and will not knowingly sell its products for use in such applications, unless it receives an adequate "product liability indemnification insurance agreement". **Supertex** does not assume responsibility for use of devices described and limits its liability to the replacement of the devices determined defective due to workmanship. No responsibility is assumed for possible omissions or inaccuracies. Circuitry and specifications are subject to change without notice. For the latest product specifications, refer to the **Supertex** website: <http://www.supertex.com>.

©2007 **Supertex inc.** All rights reserved. Unauthorized use or reproduction is prohibited.

**Supertex inc.**  
 1235 Bordeaux Drive, Sunnyvale, CA 94089  
 TEL: (408) 222-8888 / FAX: (408) 222-4895  
[www.supertex.com](http://www.supertex.com)



## Стандарт Электрон Связь

Мы молодая и активно развивающаяся компания в области поставок электронных компонентов. Мы поставляем электронные компоненты отечественного и импортного производства напрямую от производителей и с крупнейших складов мира.

Благодаря сотрудничеству с мировыми поставщиками мы осуществляем комплексные и плановые поставки широчайшего спектра электронных компонентов.

Собственная эффективная логистика и склад в обеспечивает надежную поставку продукции в точно указанные сроки по всей России.

Мы осуществляем техническую поддержку нашим клиентам и предпродажную проверку качества продукции. На все поставляемые продукты мы предоставляем гарантию .

Осуществляем поставки продукции под контролем ВП МО РФ на предприятия военно-промышленного комплекса России , а также работаем в рамках 275 ФЗ с открытием отдельных счетов в уполномоченном банке. Система менеджмента качества компании соответствует требованиям ГОСТ ISO 9001.

Минимальные сроки поставки, гибкие цены, неограниченный ассортимент и индивидуальный подход к клиентам являются основой для выстраивания долгосрочного и эффективного сотрудничества с предприятиями радиоэлектронной промышленности, предприятиями ВПК и научно-исследовательскими институтами России.

С нами вы становитесь еще успешнее!

### Наши контакты:

**Телефон:** +7 812 627 14 35

**Электронная почта:** [sales@st-electron.ru](mailto:sales@st-electron.ru)

**Адрес:** 198099, Санкт-Петербург,  
Промышленная ул, дом № 19, литера Н,  
помещение 100-Н Офис 331