



1NT | SERIES

FIXED TEMPERATURE THERMOSTATS

Introduction

Single throw, snap-action, fixed temperature thermostat suitable for a variety of Industrial and commercial applications. 1NT is recognized by agencies around the world and depending on its configuration and application, is widely used as a regulating thermal switch, over-temperature control or pilot duty control switch.



Features

- ISO9001: 2000 certification
- Ambient temperature rating from -40°C to 240°C (-40°F to 464°F)
- 1NT base provides:
 - Low cost
 - High temperature capability
 - Clean processing
 - High impact strength
 - Low static generation
- Many termination and mounting configurations available
- Switch actions:
 - Automatic reset: Available with both normally open and normally closed switch logic
 - Manual reset: Mechanical reset device
 - Trip free manual reset: UL M2 class rating that resists consumer tampering
 - One shot: meets agency requirements for single operation device

Applications

- Power Distribution
- Automation
- Power Supplies
- Heating Systems
- HVAC
- Gas and Electric Furnace
- Boilers
- Espresso Machines
- Refrigeration
- Electric motors
- Heating Elements
- Laboratory Equipment
- Medical Equipment
- Automotive & HVOR
- Panel Heaters



STANDARD CONSTRUCTIONS

All dimensions mm (in.)

High Profile Construction

Options shown: 90° – 1/4" Q.C. terminals with Surface mount flange



Low Profile Construction

4 Post Options shown: 45° – 1/4" Q.C. terminals with 4 post and flat Al cup



Manual Reset Construction

Options shown: Flat 1/4" Q.C. terminals with Airstream mount cup



Part Types by Construction

1NT01 Auto Reset / Silver Contacts
 1NT11 Auto Reset / Gold Contacts
 1NT09 One Shot: -35°C (-31°F) Reset
 1NT10 One Shot: 0°C (32°F) Reset

1NT02 Auto Reset / Silver Contacts
 1NT02TL Low Profile / One Shot
 1NT20 Auto Reset / Gold Contacts

1NT08 Manual Reset / Silver Contacts
 1NT12 Manual Reset / Gold Contacts
 1NT15 Trip Free MR / Silver Contacts
 1NT19 Trip Free MR / Gold Contacts



STANDARD TEMPERATURES, TOLERANCES AND DIFFERENTIAL

Manual Reset and One-Shot Thermostats

Nominal Top Temperature		Open Tolerances	
°C	°F	°C	°F
<60	<140	±4.0	±7.5
61 TO 160	141 to 320	±5.0	±9.0
161 TO 204	321 to 399	±6.0	±11.0



Automatic Reset Thermostats

Nominal Top Temperature		Min. Bottom Temperature		Differential		Standard Tolerances			
						Open		Close	
°C	°F	°C	°F	°C	°F	°C	°F	°C	°F
18 to 27	65 to 80	-33	-26	11 to 16	20 to 29	±3.0	±5.5	±4.0	±7.5
				17 to 21	30 to 38	±3.0	±5.5	±4.5	±8.5
				22 to 33	39 to 59	±3.0	±5.5	±5.5	±10.0
28 to 80 and 81 to 93 ⁽¹⁾	81 to 176 and 177 to 199	-33 50	-26 122	11 to 13	20 to 23	±3.0	±5.5	±4.0	±7.5
				14 to 16	24 to 29	±3.0	±5.5	±4.5	±8.5
				17 to 33	30 to 59	±3.0	±5.5	±5.0	±9.0
94 to 121 ⁽¹⁾	200 to 249 ⁽¹⁾	50	122	11 to 16	20 to 29	±3.5	±6.5	±4.5	±8.5
				17 to 21	30 to 38	±3.5	±6.5	±5.5	±10.0
				22 to 33	39 to 59	±3.5	±6.5	±6.5	±12.0
				34 to 55	60 to 99	±5.5	±10.0	±11.0	±20.0
122 to 149	250 to 300	50	122	14 to 21	24 to 38	±4.0	±7.5	±5.5	±10.0
				21 to 33	39 to 59	±4.0	±7.5	±8.0	±14.5
				34 to 55	60 to 99	±5.5	±10.0	±11.0	±20.0
150 to 177	301 to 350	50	122	22 to 33	39 to 59	±5.0	±9.0	±9.0	±16.5
				34 to 44	60 to 79	±5.5	±10.0	±11.0	±20.0
				45 to 55	80 to 99	±5.5	±10.0	±11.0	±20.0
178-204 ⁽²⁾	351 to 399	50	122	22 to 33*	39 to 59	±5.0	±9.0	±9.0	±16.5
				34 to 44	60 to 79	±5.5	±10.0	±11.0	±20.0
				45 to 55	80 to 99	±5.5	±10.0	±11.0	±20.0

⁽¹⁾ Not valid for Fan Devices

⁽²⁾ Top Temp for Fan Devices cannot exceed 380°F (193°C)

ACCESSORIES AND OPTIONS

Flanges

Fixed Rotation Surface Mount Flange 57336

Available mounting rotation relative to terminals - 90° with Aluminum
-0°, 90° / or 57°, 127°, 135° CCW with Nickel Plated Steel



Loose Ear Surface Mount Flange 27183

Material: Aluminum



Wide Eared – Fixed Rotation Mounting Flange 57337

Material: Nickel Plated Steel
Available mounting rotation relative to terminals - 45° CCW



Bolt On Assembly 73972

Thread Specs:	Metric:	M4 x 0.7 - 6G
		M5 x 0.8 - 6G
Stud Length:	Metric:	6.15, 7.00, 8.00, 9.00 (with M4)
		8.00 (with M5)
	English:	6 x 32 - 1/2" Long
		8 x 32 - 1/4" Long
Material:	Stud:	Zinc Plated Steel
	Cap:	Aluminum



Cup Styles

Airstream Mount Integral Cup 57611

Material: Aluminum
Available mounting rotation relative to terminals – 0 or 90 Closed Bottom Only

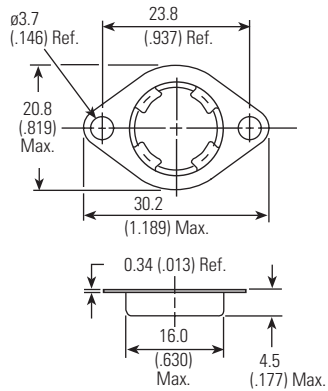

Flat Cup 73926

Materials: Aluminum, Stainless Steel or Copper



3NT Flange Cup 57366

Material: Aluminum or Copper
Closed Bottom Only



Airstream Mount Integral Cup 27185

Material: Stainless Steel
Available mounting rotation relative to terminals
0°, 45° or 90° with Closed Bottom
0° or 90° with Open Bottom



Airstream Mount Integral Cup (slotted mounting holes) 57367

Material: Aluminum
Available mounting rotation relative to terminals - 0° or 90° Closed Bottom Only



Wide-Eared Integral Cup 57608

Material: Stainless Steel
Available mounting rotation relative to terminals - 0° or 90° Closed Bottom Only



“Tear-Drop” Integral Cup 57609

Material: Stainless Steel
Available mounting rotation relative to terminals - 0° or 90° Closed Bottom Only



Large Oval Integral Cup 59122

Material: Aluminum
Available mounting rotation relative to terminals
0°, 45° or 90° with Closed Bottom
0° or 90° with Open Bottom



Standard Terminal

Solder Terminal 27182*

Material: Tin Plated Brass



Crimp Terminal 27184*

Material: Tin Plated Brass



Quick Connects

	27132	27162*	27163
Thickness (A):	0.8(.031)	0.5(.020)	0.8(.031)
Width (B):	6.3(.250)	4.8(.187)	4.8(.187)
Materials:	Brass - Solid, Ni, Ag, or Tin Plated Steel - Nickel Plated		



Screw Terminal 57200

Material: Nickel Plated Steel
M3 x 0.5 Class 6H Thread



Weld Terminal 57201

Material: Nickel Plated Steel



Weld Terminal 57312*

Material: Nickel Plated Steel

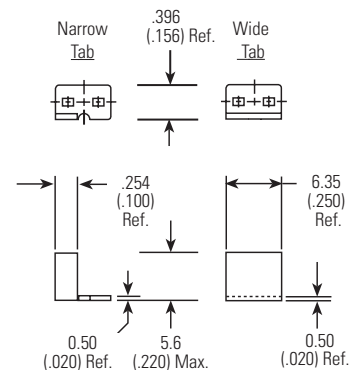

*10A Max. on all terminals 0.51 (.020) thick
All dimensions mm (in.)



ORDERING OPTIONS

EXAMPLE

Family

See Standard Construction Table

Special Processing

A - Wire Lead Assy

E - Exposed Disc

Switch Type

L - Limit⁽³⁾ switch opens on temperature rise

F - Fan⁽⁴⁾ switch closes on temperature rise

ID Number

Unique Number Designated by the factory to indicate all other attributes including Temperatures, Terminals or connectors, Mounting Options, Special Markings, and other special customer requested requirements.

⁽³⁾ Limit switch opens on temperature rise

⁽⁴⁾ Fan switch closes on temperature rise

The Temperature Code is required to set up or choose the unique part number for your application requirements.

Temperature Code

EXAMPLE

Operating Temperature

L - Limit

F - Fan

Operating Temperature

Nominal Open Temperature

Temperature

Temp. Code

C - Celsius

F - Fahrenheit

Differential

Nom. Open to Nom. Close

MR Manual Reset



UL and C-UL

Type	Max. Temp.		Cycles (X 1000)	Electrical Rating	
	°C	°F			
1NT01, 02	204	400	100	120 Vac	0 - 9 amps 10 - 17 amps*
				240 Vac	0 - 5 amps 6 - 17 amps*
				277 Vac	7.2 amps
1NT08, 15, 08E**	204	400	1 + 5	240 Vac	25 amps
1NT09, 10	204	400	1-Shot	240 Vac 277 Vac	25 amps 7.2 amps
1NT11, 20	204	400	100	125 VA 30 Vdc	1 amp
1NT12, 19	204	400	1 + 5	125 VA	
1NT01E, 02E**	204	400	100	120 Vac	10 amps

* UL rated at these current levels at specific open/close temperatures. When applying to these electrical levels, nominal open/close temperatures must be considered to determine if the thermostat selected will operate as intended in the user's application. Please consult a Sensata Engineer for additional clarification.

** "E" means exposed disc.

ENEC (DEKRA)

Type	Max Temp (°C)	Cycles	Electrical Rating
1NT01/02	204	100.000	240Vac 13.5(1.66)A
		30.000	240Vac 16(5)A
		30.000	400Vac 4(1)A
1NT02T	204	1	240Vac 16(5)A
1NT08	204	10.000	240Vac 16(5)A
		10.000	400Vac 4(1)A
1NT09	204	1	240Vac 16(5)A
1NT11	204	100.000	30Vdc 1A
1NT12	204	10.000	30Vdc 1A
1NT15	204	10.000	240Vac 16(5)A
1NT20	204	100.000	30Vdc 1A
1NT30	204	10.000	30Vdc 1A
1NT31	204	10.000	30Vdc 1A

* Parenthesis indicate inductive load ratings.

** ENEC rated at these current levels at specific open/close temperatures. When applying to these electrical levels, nominal open/close temperatures must be considered to determine if the thermostat selected will operate as intended in the user's application. Please consult a Sensata Engineer for additional clarification.



THERMOSTAT HANDLING TIPS

1. Exposed disc devices should be kept free of dust and particulates, liquid and condensation. The face of the disc should never be snapped.
2. Mounting screws and drivers for use with smaller integral cups and flanges should be sized to provide adequate clearance to the thermostat body.
3. The installation force applied to the cup face should not exceed 66.7N (15 lbs.).
4. The maximum reset force on the manual reset and trip free button is 22.2N (5 lbs.).

IMPORTANT NOTICE

These devices are not intended for use as service or repair components, strictly for use by Original Equipment Manufacturer. This product is not rated as explosion proof and should not be applied in any application where flammable vapors or dust is present. End of life failure of this device may result in either open or closed circuit condition, and as such, OEMs must apply end of life protection in series, per agency requirements.

Users are solely responsible for proper design, application and function of this product in the end product or system. Users must evaluate the suitability of these devices in their application with respect to Temperature Settings, Mechanical and Electrical Life Cycles, Electrical loads and Environmental conditions.

These products are not environmentally sealed and have exposed electrical components. They are not intended to be used in applications where exposure to condensing or dripping liquids, Immersion in liquids, or exposure to other environment contaminants may occur.

Excessive mechanical cycling, high electrical loading or exposure to liquids or other environmental contaminants, as noted above, may compromise the electrical insulating properties of these devices. Such conditions may result in electric insulation breakdown accompanied by localized heating. The device may remain permanently closed or open as a result of these conditions as well as at normal end of life.



WARNINGS



RISK OF MATERIAL DAMAGE AND HOT ENCLOSURE

- The product's side panels may be hot, allow the product to cool before touching
- Follow proper mounting instructions including torque values
- Do not allow liquids or foreign objects to enter this product

Failure to follow these instructions can result in serious injury, or equipment damage.



HAZARD OF ELECTRIC SHOCK, EXPLOSION OR ARCH FLASH

- Disconnect all power before installing or working with this equipment
- Verify all connections and replace all covers before turning on power

Failure to follow these instructions will result in death or serious injury

Sensata Technologies, Inc. ("Sensata") data sheets are solely intended to assist designers ("Buyers") who are developing systems that incorporate Sensata products (also referred to herein as "components"). Buyer understands and agrees that Buyer remains responsible for using its independent analysis, evaluation and judgment in designing Buyer's systems and products. Sensata data sheets have been created using standard laboratory conditions and engineering practices. Sensata has not conducted any testing other than that specifically described in the published documentation for a particular data sheet. Sensata may make corrections, enhancements, improvements and other changes to its data sheets or components without notice.

Buyers are authorized to use Sensata data sheets with the Sensata component(s) identified in each particular data sheet. HOWEVER, NO OTHER LICENSE, EXPRESS OR IMPLIED, BY ESTOPPEL OR OTHERWISE TO ANY OTHER SENSATA INTELLECTUAL PROPERTY RIGHT, AND NO LICENSE TO ANY THIRD PARTY TECHNOLOGY OR INTELLECTUAL PROPERTY RIGHT, IS GRANTED HEREIN. SENSATA DATA SHEETS ARE PROVIDED "AS IS". SENSATA MAKES NO WARRANTIES OR REPRESENTATIONS WITH REGARD TO THE DATA SHEETS OR USE OF THE DATA SHEETS, EXPRESS, IMPLIED OR STATUTORY, INCLUDING ACCURACY OR COMPLETENESS. SENSATA DISCLAIMS ANY WARRANTY OF TITLE AND ANY IMPLIED WARRANTIES OF MERCHANTABILITY, FITNESS FOR A PARTICULAR PURPOSE, QUIET ENJOYMENT, QUIET POSSESSION, AND NON-INFRINGEMENT OF ANY THIRD PARTY INTELLECTUAL PROPERTY RIGHTS WITH REGARD TO SENSATA DATA SHEETS OR USE THEREOF.

All products are sold subject to Sensata's terms and conditions of sale supplied at www.sensata.com SENSATA ASSUMES NO LIABILITY FOR APPLICATIONS ASSISTANCE OR THE DESIGN OF BUYERS' PRODUCTS. BUYER ACKNOWLEDGES AND AGREES THAT IT IS SOLELY RESPONSIBLE FOR COMPLIANCE WITH ALL LEGAL, REGULATORY AND SAFETY-RELATED REQUIREMENTS CONCERNING ITS PRODUCTS, AND ANY USE OF SENSATA COMPONENTS IN ITS APPLICATIONS, NOTWITHSTANDING ANY APPLICATIONS-RELATED INFORMATION OR SUPPORT THAT MAY BE PROVIDED BY SENSATA.

Mailing Address: Sensata Technologies, Inc., 529 Pleasant Street, Attleboro, MA 02703, USA.

CONTACT US

Americas

+1 (888) 438 2214
sensors@sensata.com

Europe, Middle East & Africa

+31 (74) 357 8156
temperature-info.eu@sensata.com

Asia Pacific

sales.isasia@list.sensata.com
China +86 (21) 2306 1500
Japan +81 (45) 277 7117
Korea +82-10-9218-1179
India +91 (80) 67920890
Rest of Asia +886 (2) 27602006
ext 2808



Стандарт Электрон Связь

Мы молодая и активно развивающаяся компания в области поставок электронных компонентов. Мы поставляем электронные компоненты отечественного и импортного производства напрямую от производителей и с крупнейших складов мира.

Благодаря сотрудничеству с мировыми поставщиками мы осуществляем комплексные и плановые поставки широчайшего спектра электронных компонентов.

Собственная эффективная логистика и склад в обеспечивает надежную поставку продукции в точно указанные сроки по всей России.

Мы осуществляем техническую поддержку нашим клиентам и предпродажную проверку качества продукции. На все поставляемые продукты мы предоставляем гарантию .

Осуществляем поставки продукции под контролем ВП МО РФ на предприятия военно-промышленного комплекса России , а также работаем в рамках 275 ФЗ с открытием отдельных счетов в уполномоченном банке. Система менеджмента качества компании соответствует требованиям ГОСТ ISO 9001.

Минимальные сроки поставки, гибкие цены, неограниченный ассортимент и индивидуальный подход к клиентам являются основой для выстраивания долгосрочного и эффективного сотрудничества с предприятиями радиоэлектронной промышленности, предприятиями ВПК и научно-исследовательскими институтами России.

С нами вы становитесь еще успешнее!

Наши контакты:

Телефон: +7 812 627 14 35

Электронная почта: sales@st-electron.ru

Адрес: 198099, Санкт-Петербург,
Промышленная ул, дом № 19, литера Н,
помещение 100-Н Офис 331