

DESCRIPTION

The MP3384L is a step-up converter to control up to 4 white LED strings for LCD backlighting.

The MP3384L employs a fixed-switching frequency that can be selected from either 625kHz or 1.25MHz. It takes a 3V-to-25V input supply. The low-end input voltage allows the MP3384L to power a tablet display from a single battery.

The MP3384L has 4 internal current sources to independently regulate the current in each LED string to a value set by an external, current-setting resistor. It achieves current balance within 2.5% regulation accuracy between strings. Its low 600mV regulation voltage for the LED current sources reduces power loss and improves efficiency.

The MP3384L features multiple protections, including under-voltage lockout, MOSFET current limiting, over-voltage protection, open/short LED protection, and thermal shut-down.

The MP3384L is available in a 3mm×3mm QFN16 package.

FEATURES

- Highly Efficient
- 3V-to-25V Input Voltage Range
- 50V Maximum Step-Up Voltage
- Balanced Driver for 4 WLED Strings
- 2.5% Current Matching Accuracy Between Strings
- Selectable Switching Frequency: 625kHz or 1.25MHz
- PWM Dimming
- Programmable Over-Voltage Protection
- Under-Voltage Lockout
- Open and Short LED Protection
- Thermal Shutdown
- 3mm×3mm 16-pin QFN Package

APPLICATIONS

- Notebook Computers
- Netbooks and Tablet Computers
- Digital Picture Frames
- Hand-Held Terminal Displays
- Automotive Systems

All MPS parts are lead-free and adhere to the RoHS directive. For MPS green status, please visit MPS website under Quality Assurance. "MPS" and "The Future of Analog IC Technology" are Registered Trademarks of Monolithic Power Systems, Inc.

TYPICAL APPLICATION

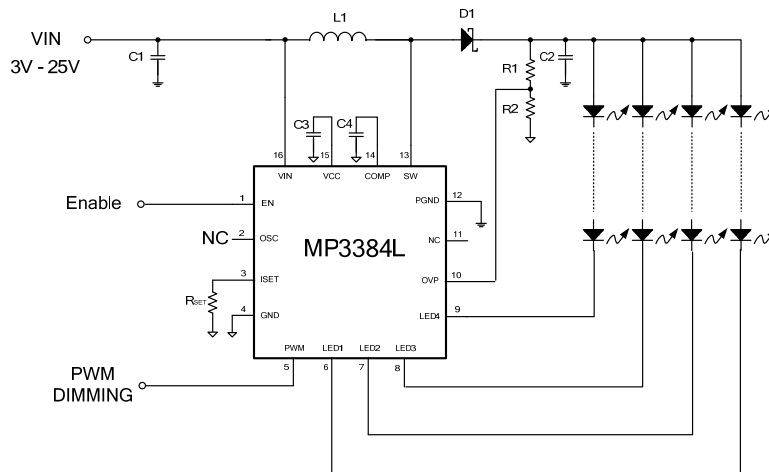

ORDERING INFORMATION

Part Number*	Package	Top Marking
MP3384LGQ	QFN16 (3mm × 3mm)	AFZ

* For Tape & Reel, add suffix -Z (e.g. MP3384LGQ-Z)

PACKAGE REFERENCE

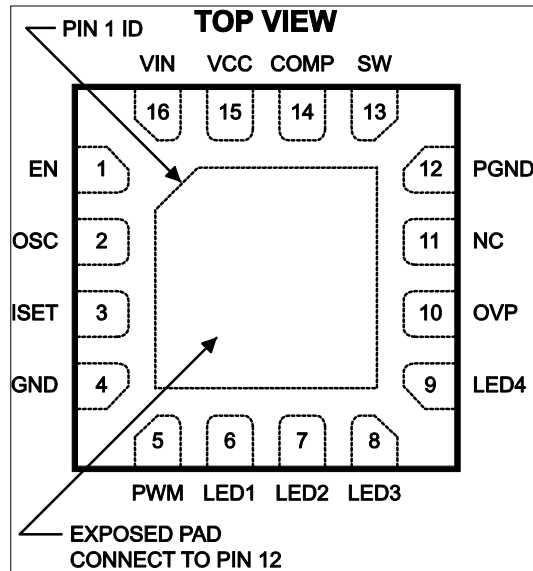

ABSOLUTE MAXIMUM RATINGS ⁽¹⁾

V_{IN}	-0.3V to +30V
V_{SW} , V_{LED1} to V_{LED4}	-1V to +50V
All Other Pins	-0.3V to +6V
Continuous Power Dissipation ($T_A = +25^\circ\text{C}$) ⁽²⁾	2.1W
Junction Temperature	150°C
Lead Temperature	260°C
Storage Temperature	-65°C to +150°C

Recommended Operating Conditions ⁽³⁾

Supply Voltage V_{IN}	+3V to +25V
Operating Junction Temp. (T_J)	-40°C to +125°C

Thermal Resistance ⁽⁴⁾	θ_{JA}	θ_{JC}
QFN16 (3mm × 3mm)	60	12... °C/W

Notes:

- 1) Exceeding these ratings may damage the device.
- 2) The maximum allowable power dissipation is a function of the maximum junction temperature $T_{J(MAX)}$, the junction-to-ambient thermal resistance θ_{JA} , and the ambient temperature T_A . The maximum allowable continuous power dissipation at any ambient temperature is calculated by $P_{D(MAX)} = (T_{J(MAX)} - T_A) / \theta_{JA}$. Exceeding the maximum allowable power dissipation will cause excessive die temperature, and the regulator will go into thermal shutdown. Internal thermal shutdown circuitry protects the device from permanent damage.
- 3) The device is not guaranteed to function outside of its operation conditions.
- 4) Measured on JESD51-7, 4-layer PCB.

ELECTRICAL CHARACTERISTICS

$V_{IN} = 12V$, $V_{EN} = 5V$, $T_A = +25^{\circ}C$, unless otherwise noted.

Parameters	Symbol	Condition	Min	Typ	Max	Units
Operating Input Voltage	V_{IN}		3		25	V
Supply Current (Quiescent)	I_Q	$V_{IN}=12V$, $V_{EN}=5V$, no load.		1.8		mA
Supply Current (Shutdown)	I_{ST}	$V_{EN}=0V$, $V_{IN}=12V$			2	μA
LDO Output Voltage	V_{CC}	$V_{EN}=5V$, $6V < V_{IN} < 25V$, $0 < I_{VCC} < 10mA$	4.5	5	5.5	V
VCC High Threshold		V_{CC_rising}			3	V
VCC Low Threshold		$V_{CC_falling}$	2.2			V
EN ON Threshold	V_{EN_ON}	V_{EN} Rising	1.8			V
EN OFF Threshold	V_{EN_OFF}	V_{EN} Falling			0.6	V
STEP-UP CONVERTER						
SW On-Resistance	R_{DS_ON}	$I_{DS}=20mA$		0.5		Ω
SW Leakage Current	I_{SW_LK}	$V_{SW}=45V$			1	μA
Switching Frequency	f_{SW}	$V_{OSC}=V_{CC}$ or Floating	1.0	1.25	1.5	MHz
		$V_{OSC}=0V$	500	625	750	kHz
OSC High-Level Threshold	V_{OSC_H}		2.1			V
OSC Low-Level Threshold	V_{OSC_L}				0.8	V
Minimum ON Time	τ_{ON_MIN}	PWM Mode without Pulse Skipping		100		ns
Maximum Duty Cycle	D_{MAX}		90	93	96	%
SW Current Limit	I_{SW_LIMIT}	Duty=90%	1.2			A
COMP Transconductance	G_{COMP}	$\Delta I_{COMP} = \pm 10\mu A$		100		$\mu A/V$
COMP Output Current	I_{COMP}			60		μA
PWM DIMMING						
PWM High-Level Threshold	V_{PWML_H}		1.5			V
PWM Low-Level Threshold	V_{PWML_L}				0.6	V
LED CURRENT REGULATION						
LEDx Average Current	I_{LED}	$R_{ISET}=60.4k\Omega$	19.4	20	20.6	mA
Current Matching ⁽⁵⁾		$I_{LED}=20mA$			2.5	%
Maximum LED Current per String	I_{LEDmax}	$R_{ISET}=40.2k\Omega$		30		mA
LEDx Regulation Voltage	V_{LEDX}	$I_{LED}=20mA$		600		mV
PROTECTION						
OVP Over Voltage Threshold	V_{OVP_OV}	Rising Edge	1.17	1.23	1.3	V
OVP UVLO Threshold	V_{OVP_UV}	Step-Up-Converter Failure	48	70	102	mV
LEDx Over Voltage Threshold	V_{LEDX_OV}	$V_{IN} > 5.5V$	5.1	5.5	5.9	V
LEDx UVLO Threshold	V_{LEDX_UV}		135	180	235	mV
Thermal Shutdown Threshold	T_{ST}			150		$^{\circ}C$
LEDx Over-Voltage Fault Timer			1.3	1.6	1.9	ms

Notes:

5) Matching is defined as the difference between the maximum and minimum current divided by 2*average current

PIN FUNCTIONS

Pin #	Name	Description
1	EN	Enable Control Input. Do not float.
2	OSC	Switching Frequency Set. When floating or connected to VCC, the switching frequency is 1.25MHz. When connected to GND, the switching frequency is 625kHz.
3	ISSET	LED Current Set. Tie a current-setting resistor from this pin to ground to program the current in each LED string. $I_{LED} = \frac{1000 \times 1.21V}{R_{SET}}$
4	GND	Analog Ground.
5	PWM	PWM Input. Controls the PWM-burst-mode dimming frequency and duty cycle.
6	LED1	LED String 1, Current Input. The open-drain output of an internal, dimming-control switch. Connect the LED String 1 cathode to this pin. If not used, connect Vout to this pin.
7	LED2	LED String 2, Current Input. The open-drain output of an internal, dimming-control switch. Connect the LED String 1 cathode to this pin. If not used, connect Vout to this pin.
8	LED3	LED String 3, Current Input. The open-drain output of an internal, dimming-control switch. Connect the LED String 1 cathode to this pin. If not used, connect Vout to this pin.
9	LED4	LED String 4, Current Input. The open-drain output of an internal, dimming-control switch. Connect the LED String 1 cathode to this pin. If not used, connect Vout to this pin.
10	OVP	Over-Voltage Protection. Connect to the tap of a resistor divider to program the OVP threshold. Triggers OVP protection when V_{OVP} reaches 1.23V.
11	NC	No Connection.
12	PGND	Power Ground.
13	SW	Power-Switch Output. Drain of the internal MOSFET. Connect the power inductor and output rectifier to SW. V_{SW} can swing between GND and 50V.
14	COMP	Compensation. Compensates the regulatory control loop. Connect a capacitor or a series RC network from COMP to GND.
15	VCC	Internal, 5V, Linear-Regulator Output. Powers the internal MOSFET's gate driver and the internal-control circuitry. Bypass VCC to GND with a ceramic capacitor.
16	VIN	Supply Input. Powers the MP3384L chip. Apply a 3V-to-25V power source. Requires local bypassing.
Exposed Pad		Connect to PGND

TYPICAL PERFORMANCE CHARACTERISTICS

$V_{IN} = 12V$, 10 LEDs in series, 4 strings in parallel, 20mA/string, unless otherwise noted.

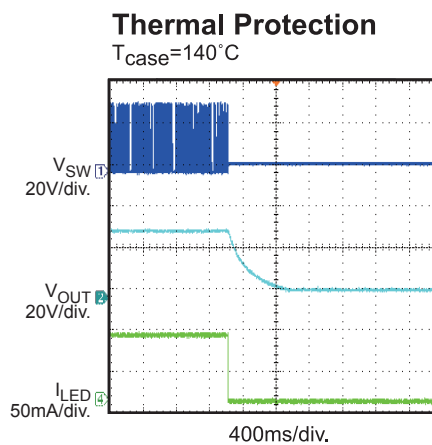
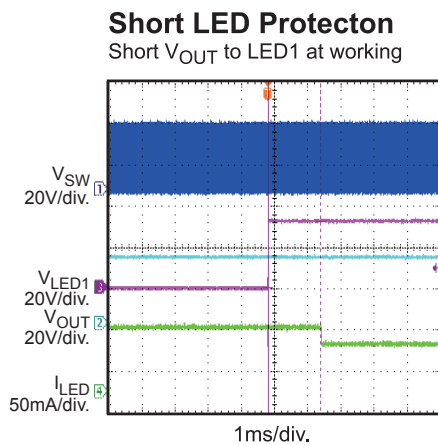
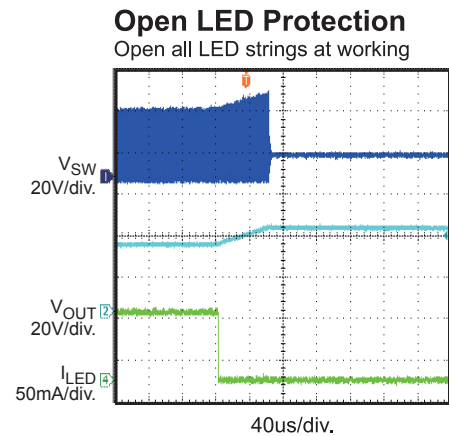
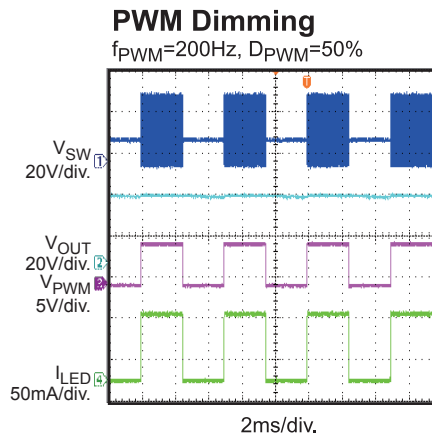
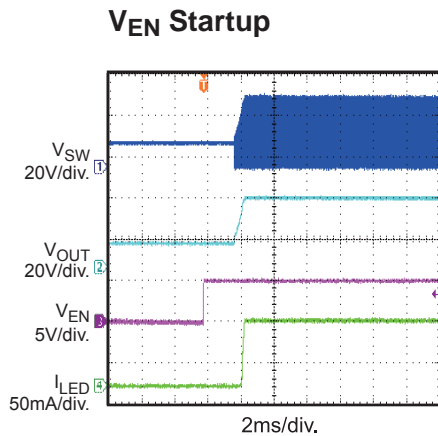
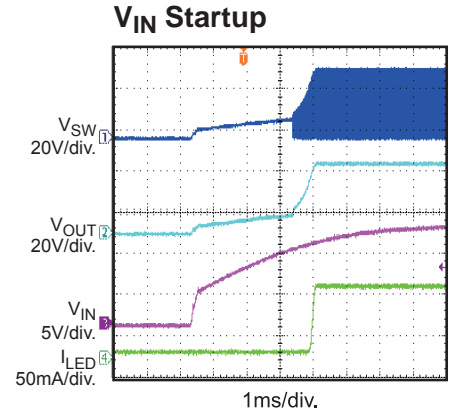
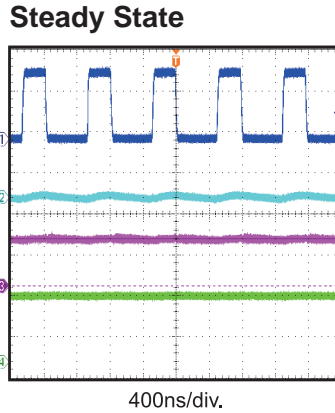
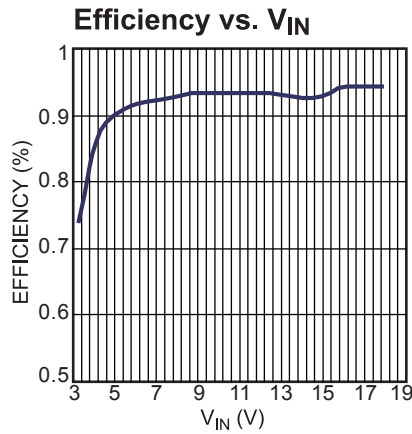

BLOCK DIAGRAM

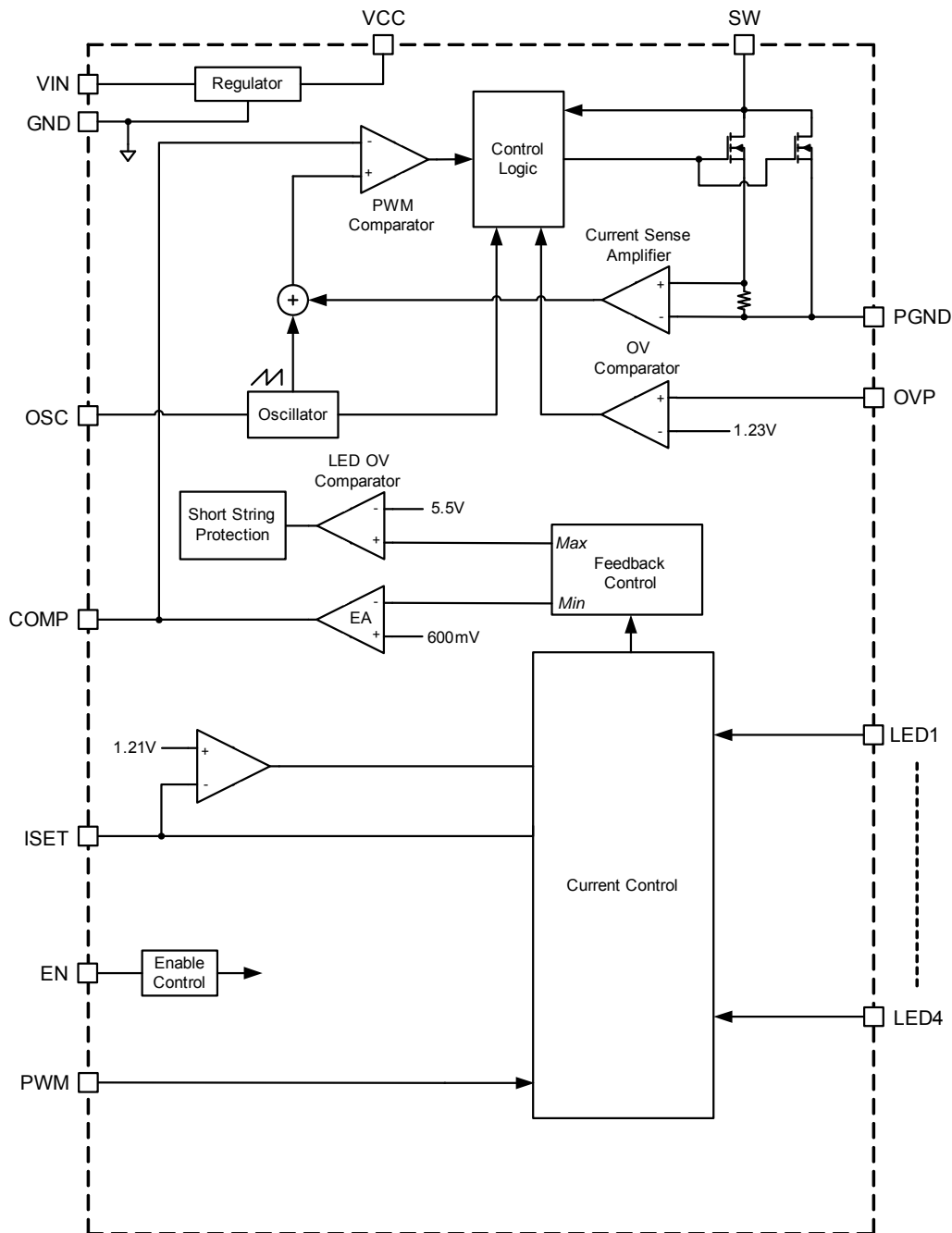

Figure 1: Functional Block Diagram

OPERATION

The MP3384L is a step-up converter with peak-current mode that regulates the LED current in each of its 4 channels. The block diagram (Figure 1) illustrates its operation.

Internal 5V Regulator

The MP3384L employs an internal linear regulator (VCC) to supply the internal MOSFET gate driver and the internal control circuitry. VCC drops to 0V when the chip shuts down. If VIN is lower than 5.5V, tie VCC and VIN together. The MP3384L features under-voltage lockout to disable the chip until VCC exceeds the UVLO threshold. UVLO hysteresis is approximately 200mV.

System Startup

When the MP3384L is enabled, the chip checks the topology connection first. The chip checks for a Schottky diode on the OVP pin. A V_{OVP} below 70mV disables the chip. The MP3384L then checks for UVLO and OTP threshold crossings before an internal soft-start drives the step-up converter.

For best results, apply the enable signal after applying both the input voltage and the PWM dimming signal.

Step-Up Converter

The MP3384L's selectable operating frequency (1.25MHz or 625kHz) optimizes for external component sizes and efficiency.

When each cycle starts, the MOSFET turns ON after the internal clock. A stabilizing ramp added to the output of the current-sense amplifier prevents sub-harmonic oscillations at duty cycles greater than 50% before it enters the PWM comparator. When this summed voltage equals the error amplifier's output voltage (V_{COMP}), the MOSFET turns OFF.

The output of the internal error amplifier is the amplified difference between the 600mV reference voltage and the feedback voltage. The converter automatically chooses the lowest active LEDx pin voltage as the boost-control loop's

feedback to regulate the output voltage to all the LED arrays.

If the feedback voltage drops below the 600mV reference, the output of the error amplifier increases, increasing the current flowing through the MOSFET to increase the output power for closed-loop, output-voltage regulation.

At light-loads or when $V_{out} \approx V_{in}$, the converter runs in pulse-skipping mode to turn the MOSFET on for the minimum ON time (approximately 100ns). Then the converter powers the output in the remaining time. The MOSFET will remain OFF until the output voltage requires another boost.

Dimming Control

The MP3384L provides PWM dimming. PWM dimming uses the PWM signal to determine the size of the current signals from each of the 4 LED channels. The brightness of the LED array is directly proportional to the duty cycle of the PWM signal.

Open-String Protection

Open-string protection relies on over-voltage protection (OVP) to monitor an LEDx pin is pulled to ground and V_{OUT} continues to rise until it reaches the OVP threshold. Then the part records the LEDx pin voltages less than 180mV before forcing the remaining LED strings back into tight regulation. The string with the highest voltage drop is the reference string during output regulation.

The MP3384L tries to light at least one string, and if all strings in use are open, the MP3384L shuts down the step-up converter. The part retains the short information until the part shuts down.

Short-String Protection

The MP3384L monitors the LEDx pin voltages for LED string shorts. If one or more strings are shorted, the respective LEDx pin rises to the boost output and tolerates high voltage stress. If the LEDx pin voltage exceeds 5.5V, this even is considered a short string. When a short string fault continues for more than 1.6ms, the string is recorded and disabled. Once a string turns OFF,

its current regulation is forced to disconnect from the output voltage loop. The recorded LED strings remain OFF until the part restarts. If all strings in use are short, the MP3384L will shut down the step-up converter.

APPLICATION INFORMATION

Selecting the Switching Frequency

Set the switching frequency to either 625kHz or 1.25MHz. A bi-level switching-frequency-select (OSC) input sets the internal oscillator frequency for the step-up converter. When the OSC pin connects to GND, the switching frequency is 625kHz. When OSC is left floating or connected to VCC, the frequency is 1.25MHz.

Setting the LED Current

The LED string currents are identical and set through the current setting resistor on the ISET pin.

$$I_{LED} = \frac{1000 \times 1.21V}{R_{SET}}$$

For $R_{SET}=60.4k\Omega$, the LED current is 20mA. Do not leave the ISET pin floating.

Setting Over-Voltage Protection

Over-voltage protection (OVP) implements open-string protection. In some cases, an LED string failure results in a feedback voltage of 0V. The part keeps boosting V_{out} , until it reaches the programmed OVP threshold. Then the chip stops boosting V_{out} .

To ensure that the chip functions properly, select an appropriate OVP resistor divider value. The recommended OVP point is about 1.3 times V_{out} for normal operation.

$$V_{OVP} = 1.23V \frac{R1 + R2}{R2}$$

PWM Dimming Mode

The MP3384L provides PWM dimming through an external PWM signal.

Apply a PWM dimming signal ranging from 100Hz to 2kHz to the PWM pin. The minimum recommended amplitude of the PWM signal is 1.5V (See Figure 2).

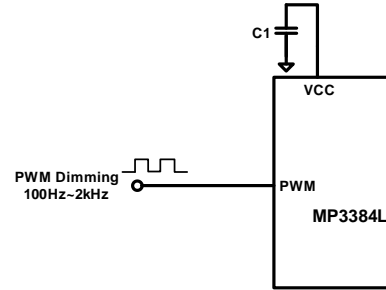

Figure 2: PWM Dimming

Selecting the Inductor

A 22 μ H (for 1.25MHz) or 47 μ H (for 625kHz) inductor with a DC current rating at least 40% higher than the maximum input current is recommended for most applications. For highest efficiency, minimize the inductor's DC resistance.

Selecting the Input Capacitor

The input capacitor reduces the surge current drawn from the input supply and the switching noise from the device. The input capacitor impedance at the switching frequency should be less than the input source impedance to prevent a high-frequency, switching current from passing through the input. Use ceramic capacitors with X5R or X7R dielectrics because of their low ESR and small temperature coefficients. For most applications, a 4.7 μ F capacitor is sufficient.

Selecting the Output Capacitor

The output capacitor reduces the output voltage ripple and ensures feedback loop stability. The output capacitor impedance should be low at the switching frequency. Ceramic capacitors with X7R dielectrics are recommended for their low ESR characteristics. For most applications, a 2.2 μ F ceramic capacitor is sufficient.

Layout Considerations

Careful attention must be paid to the PCB board layout and components placement. Proper layout of the high frequency switching path is critical to prevent noise and electromagnetic interference. High-frequency pulse current flows through the loop: MP3384L SW to PGND pin (U1), output diode (D1), and output capacitor (C3). The loop path must be as short as possible (See Figure 3).

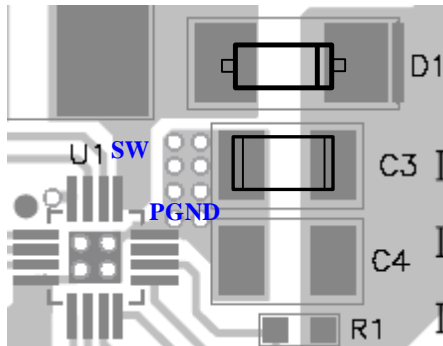

Figure 3: Example Layout

The exposed pad connects internally to the GND pin, and all logic signals refer to GND. Externally connect PGND to GND, and placed far from the logic signals.

TYPICAL APPLICATION CIRCUIT

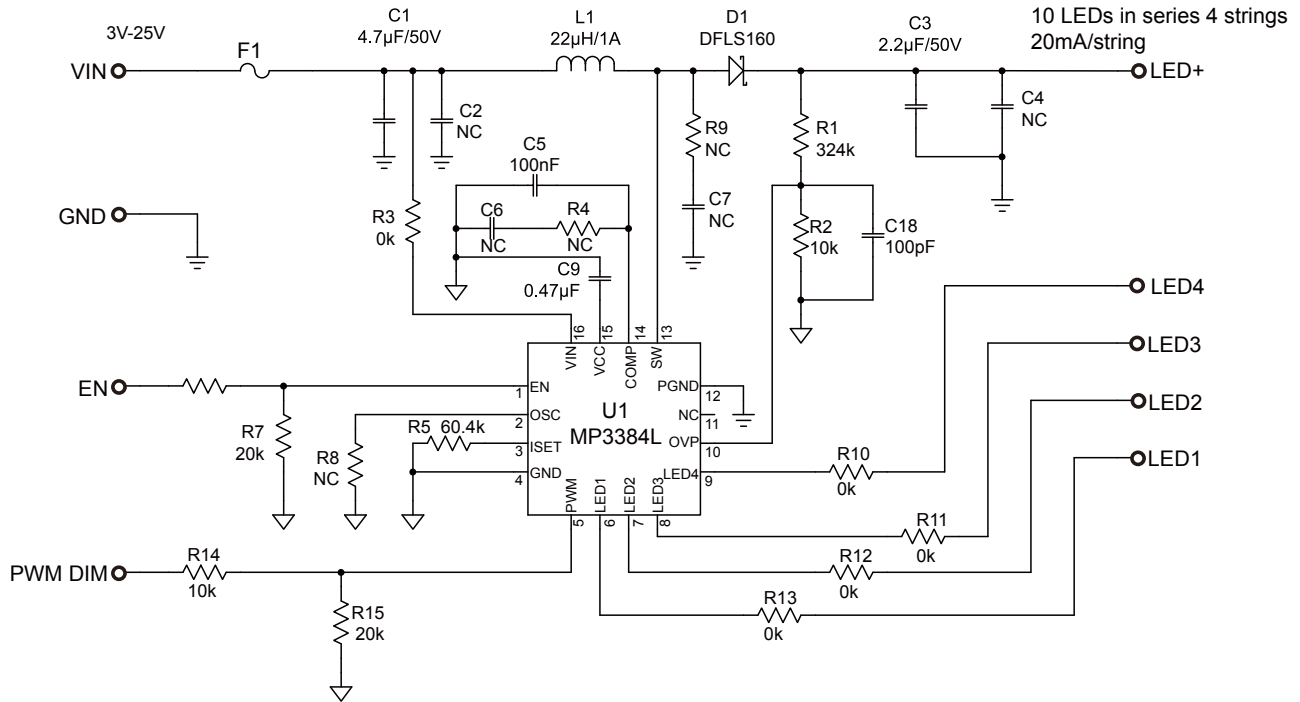
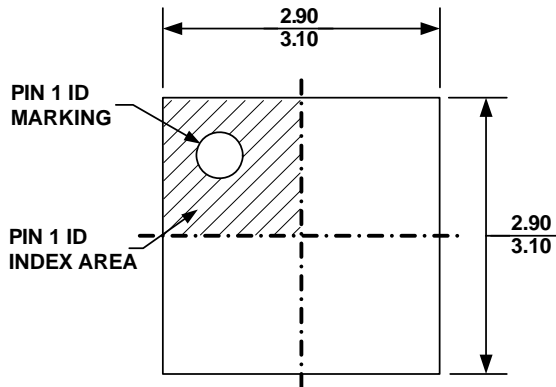

Figure 4—Driving 10 LED in Series and 4 String LED Application Circuit

PACKAGE INFORMATION

QFN16 (3X3mm)



TOP VIEW

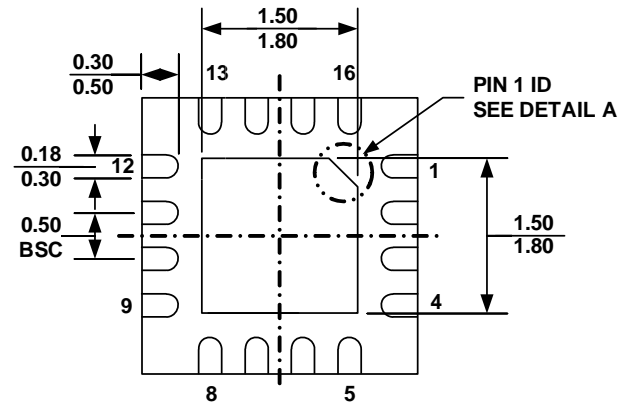

BOTTOM VIEW

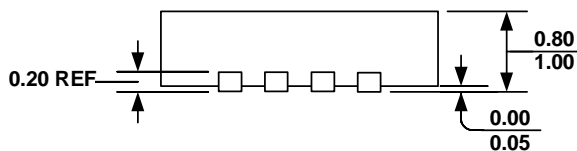

SIDE VIEW

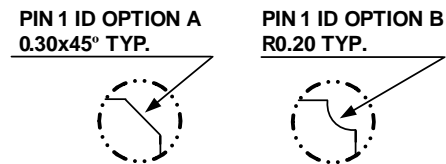

DETAIL A

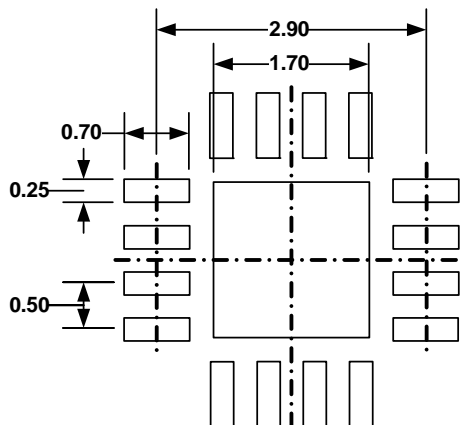

RECOMMENDED LAND PATTERN

NOTE:

- 1) ALL DIMENSIONS ARE IN MILLIMETERS
- 2) EXPOSED PADDLE SIZE DOES NOT INCLUDE MOLD FLASH
- 3) LEAD COPLANARITY SHALL BE 0.10 MILLIMETER MAX
- 4) DRAWING CONFORMS TO JEDEC MO-220, VARIATION VEED-4.
- 5) DRAWING IS NOT TO SCALE

NOTICE: The information in this document is subject to change without notice. Users should warrant and guarantee that third party Intellectual Property rights are not infringed upon when integrating MPS products into any application. MPS will not assume any legal responsibility for any said applications.



Стандарт Электрон Связь

Мы молодая и активно развивающаяся компания в области поставок электронных компонентов. Мы поставляем электронные компоненты отечественного и импортного производства напрямую от производителей и с крупнейших складов мира.

Благодаря сотрудничеству с мировыми поставщиками мы осуществляем комплексные и плановые поставки широчайшего спектра электронных компонентов.

Собственная эффективная логистика и склад в обеспечивает надежную поставку продукции в точно указанные сроки по всей России.

Мы осуществляем техническую поддержку нашим клиентам и предпродажную проверку качества продукции. На все поставляемые продукты мы предоставляем гарантию .

Осуществляем поставки продукции под контролем ВП МО РФ на предприятия военно-промышленного комплекса России , а также работаем в рамках 275 ФЗ с открытием отдельных счетов в уполномоченном банке. Система менеджмента качества компании соответствует требованиям ГОСТ ISO 9001.

Минимальные сроки поставки, гибкие цены, неограниченный ассортимент и индивидуальный подход к клиентам являются основой для выстраивания долгосрочного и эффективного сотрудничества с предприятиями радиоэлектронной промышленности, предприятиями ВПК и научно-исследовательскими институтами России.

С нами вы становитесь еще успешнее!

Наши контакты:

Телефон: +7 812 627 14 35

Электронная почта: sales@st-electron.ru

Адрес: 198099, Санкт-Петербург,
Промышленная ул, дом № 19, литера Н,
помещение 100-Н Офис 331