

Quad Complementary CMOS Analog Switch

DESCRIPTION

The versatile DG213 analog switch has two NC and two NO switches. It can be used in various configurations, including four single-pole single-throw (SPST), two single-pole double-throw (SPDT), one "T" switch, one DPDT, etc. This device is fabricated in a Vishay Siliconix' proprietary high-voltage silicon gate CMOS process, resulting in lower on-resistance, lower leakage, higher speed, and lower power consumption.

This analog switch was designed for a wide variety of general purpose applications in telecommunications, instrumentation, process control, computer peripherals, etc. An improved charge injection compensation design minimizes switching transients. These switches can handle up to ± 22 V, and have an improved continuous current rating of 30 mA. An epitaxial layer prevents latchup.

All switches feature true bi-directional performance in the on condition, and will block signals to the supply levels in the off condition.

For additional information, please refer to Application Note AN208 (FaxBack document #70606).

FEATURES

- ± 22 V supply voltage rating
- TTL and CMOS compatible logic
- Low on-resistance - $r_{DS(on)}$: 45 Ω
- Low leakage - $I_{D(on)}$: 20 pA
- Single supply operation possible
- Extended temperature range
- Fast switching - t_{ON} : 85 ns

BENEFITS

- Low charge injection - Q: 1 pC
- Wide analog signal range
- Simple logic interface
- Higher accuracy
- Minimum transients
- Reduced power consumption
- Low cost

APPLICATIONS

- Industrial instrumentation
- Test equipment
- Communications systems
- Computer peripherals
- Portable instruments
- Sample-and-hold circuits



Available
RoHS*
COMPLIANT

FUNCTIONAL BLOCK DIAGRAM AND PIN CONFIGURATION



TRUTH TABLE		
Logic	SW ₁ , SW ₄	SW ₂ , SW ₃
0	OFF	ON
1	ON	OFF

Logic "0" ≤ 0.8 V
Logic "1" ≥ 2.4 V

* Pb containing terminations are not RoHS compliant, exemptions may apply.



ORDERING INFORMATION			
Temp. Range	Package	Standard Part Number	Lead (Pb)-free Part Number
- 40 °C to 85 °C	16-Pin Plastic DIP	DG213DJ	DG213DJ-E3
	16-Pin Narrow SOIC	DG213DY DG213DY-T1	DG213DY-E3 DG213DY-T1-E3
	16-Pin TSSOP	DG213DQ DG213DQ-T1	DG213DQ-E3 DG213DQ-T1-E3

ABSOLUTE MAXIMUM RATINGS $T_A = 25\text{ °C}$, unless otherwise noted			
Parameter		Limit	Unit
Voltages Referenced V_+ to V_-		44	V
GND		25	
Digital Inputs ^a V_S, V_D		(V_-) - 2 to (V_+) + 2 or 30 mA, whichever occurs first	
Current, Any Terminal		30	mA
Peak Current (Pulsed at 1 ms, 10 % duty cycle max.)		100	
Storage Temperature		- 65 to 125	°C
Power Dissipation ^b	16-Pin Plastic DIP ^c	470	mW
	16-Pin Narrow SOIC ^d	640	
	16-Pin TSSOP ^d	500	

Notes:

- a. Signals on $S_X, D_X,$ or IN_X exceeding V_+ or V_- will be clamped by internal diodes. Limit forward diode current to maximum current ratings.
- b. All leads welded or soldered to PC board.
- c. Derate 6.5 mW/°C above 75 °C.
- d. Derate 7.6 mW/°C above 75 °C.



SPECIFICATIONS							
Parameter	Symbol	Test Conditions Unless Otherwise Specified $V_+ = 15\text{ V}$, $V_- = -15\text{ V}$, $V_L = 5\text{ V}$, $V_{IN} = 2.4\text{ V}$, 0.8 V^e	Temp. ^a	D Suffix - 40 °C to 85 °C			Unit
				Min. ^c	Typ. ^b	Max. ^c	
Analog Switch							
Analog Signal Range ^d	V_{ANALOG}		Full	V-		V+	V
Drain-Source On-Resistance	$r_{DS(on)}$	$V_D = \pm 10\text{ V}$, $I_S = 1\text{ mA}$	Room		45	60	Ω
$r_{DS(on)}$ Match	$\Delta r_{DS(on)}$		Full		1	2	
Source Off Leakage Current	$I_{S(off)}$	$V_S = \pm 14\text{ V}$, $V_D = \pm 14\text{ V}$	Room	- 0.5	± 0.01	0.5	nA
Drain Off Leakage Current	$I_{D(off)}$	$V_D = \pm 14\text{ V}$, $V_S = \pm 14\text{ V}$	Full	- 5		5	
Drain On Leakage Current ^f	$I_{D(on)}$	$V_S = V_D = 14\text{ V}$	Room	- 0.5	± 0.02	0.5	
Full			Full	- 10		10	
Digital Control							
Input Voltage High	V_{INH}		Full	2.4			V
Input Voltage Low	V_{INL}		Full			0.8	
Input Current	I_{INL} or I_{INH}	V_{INH} or V_{INL}	Full	- 1		1	μA
Input Capacitance	C_{IN}		Room		5		pF
Dynamic Characteristics							
Turn-On Time	t_{ON}	$V_S = 10\text{ V}$ See Figure 2	Room		85	130	ns
Turn-Off Time	t_{OFF}		Room		55	100	
Break-Before-Make Time Delay	t_D	$V_S = 10\text{ V}$, See Figure 3	Room	15	25		
Charge Injection	Q	$C_L = 1000\text{ pF}$, $V_g = 0\text{ V}$, $R_g = 0\ \Omega$	Room		1		pC
Source-Off Capacitance	$C_{S(off)}$	$V_S = 0\text{ V}$, $f = 1\text{ MHz}$	Room		5		pF
Drain-Off Capacitance	$C_{D(off)}$		Room		5		
Channel On Capacitance	$C_{D(on)}$	$V_D = V_S = 0\text{ V}$, $f = 1\text{ MHz}$	Room		16		
Off-Isolation	OIRR	$C_L = 15\text{ pF}$, $R_L = 50\ \Omega$ $V_S = 1\text{ V}_{RMS}$, $f = 100\text{ kHz}$	Room		90		dB
Channel-to-Channel Crosstalk	X_{TALK}		Room		95		
Power Supply							
Positive Supply Current	I_+	$V_{IN} = 0$ or 5 V	Room			1	μA
Negative Supply Current	I_-		Full	- 1		5	
Logic Supply Current	I_L		Room			1	
Power Supply Range for Continuous Operation	V_{OP}		Full	± 3		± 22	V



SPECIFICATIONS for Unipolar Supply							
Parameter	Symbol	Test Conditions Unless Otherwise Specified $V_+ = 12\text{ V}$, $V_- = 0\text{ V}$, $V_L = 5\text{ V}$, $V_{IN} = 2.4\text{ V}$, 0.8 V^e	Temp. ^a	D Suffix - 40 °C to 85 °C			Unit
				Min. ^c	Typ. ^b	Max. ^c	
Analog Switch							
Analog Signal Range ^d	V_{ANALOG}		Full	V-		V+	V
Drain-Source On-Resistance	$r_{DS(on)}$	$V_D = 3\text{ V}$, $I_S = 1\text{ mA}$	Room Full		90	110 140	Ω
Dynamic Characteristics							
Turn-On Time	t_{ON}	See Figure 2	Room		125	200	ns
Turn-Off Time	t_{OFF}		Room		45	100	
Break-Before-Make Time Delay	t_D	$V_S = 8\text{ V}$, See Figure 3	Room	50	80		
Charge Injection	Q	$C_L = 1\text{ nF}$, $V_{gen} = 6\text{ V}$, $R_{gen} = 0\ \Omega$	Room		4		pC
Power Supply							
Positive Supply Current	I_+	$V_{IN} = 0\text{ or }5\text{ V}$	Room Full			1 5	μA
Negative Supply Current	I_-		Room Full	- 1 - 5			
Logic Supply Current	I_L		Room Full			1 5	
Power Supply Range for Continuous Operation	V_{OP}		Full	+ 3		+ 40	V

Notes:

- a. Room = 25 °C, Full = as determined by the operating suffix.
- b. Typical values are for DESIGN AID ONLY, not guaranteed nor subject to production testing.
- c. The algebraic convention whereby the most negative value is a minimum and the most positive a maximum, is used in this data sheet.
- d. Guarantee by design, nor subjected to production test.
- e. V_{IN} = input voltage to perform proper function.

Stresses beyond those listed under "Absolute Maximum Ratings" may cause permanent damage to the device. These are stress ratings only, and functional operation of the device at these or any other conditions beyond those indicated in the operational sections of the specifications is not implied. Exposure to absolute maximum rating conditions for extended periods may affect device reliability.

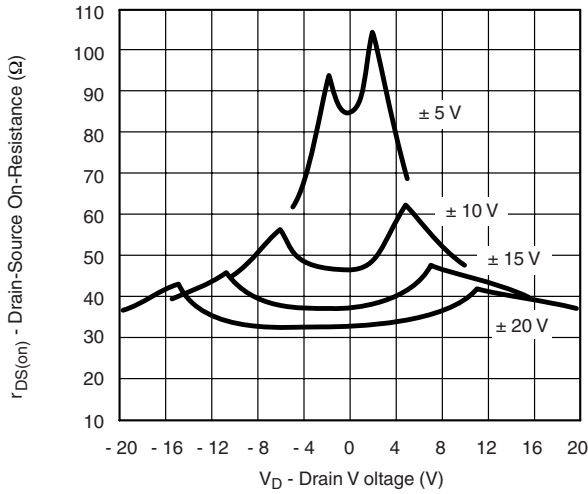
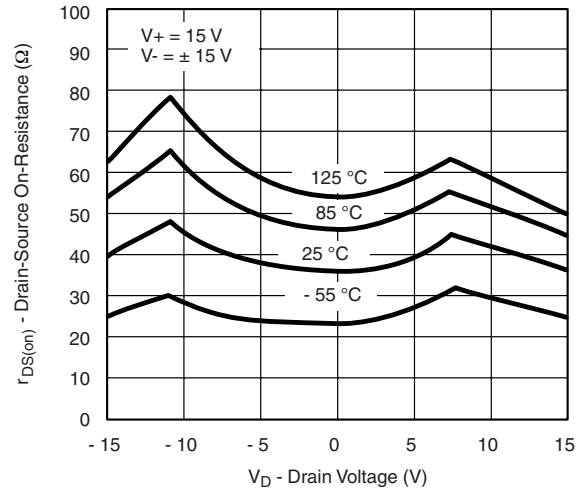
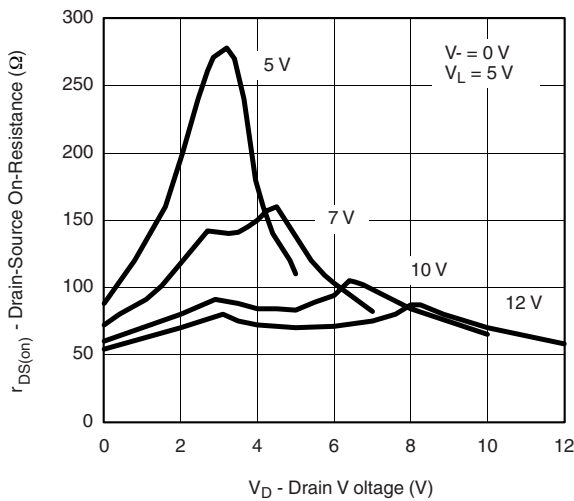
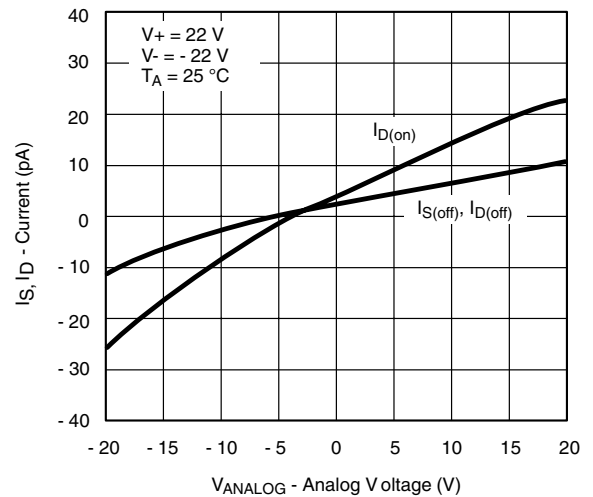
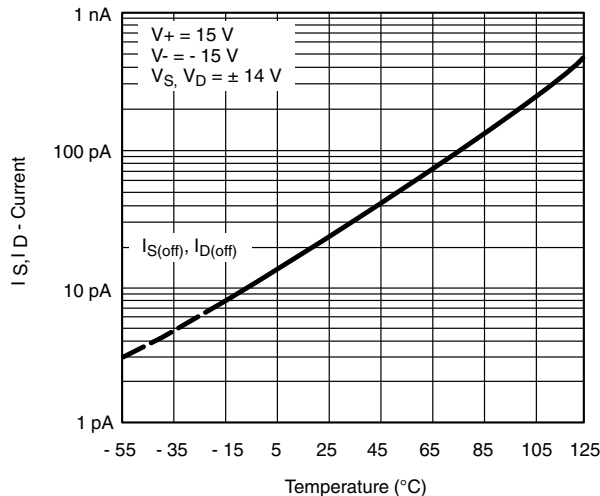
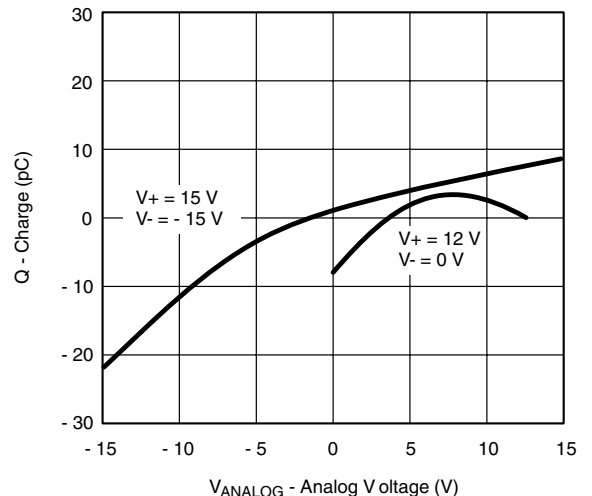
TYPICAL CHARACTERISTICS $T_A = 25^\circ\text{C}$, unless otherwise noted

 $r_{DS(on)}$ vs. V_D and Power Supply Voltages

 $r_{DS(on)}$ vs. V_D and Temperature

 $r_{DS(on)}$ vs. V_D and Single Power Supply Voltages

Leakage Currents vs. Analog Voltage

Leakage Current vs. Temperature

 Q_S, Q_D - Charge Injection vs. Analog Voltage

TYPICAL CHARACTERISTICS $T_A = 25\text{ }^\circ\text{C}$, unless otherwise noted



SCHEMATIC DIAGRAM Typical Channel



Figure 1.

TEST CIRCUITS

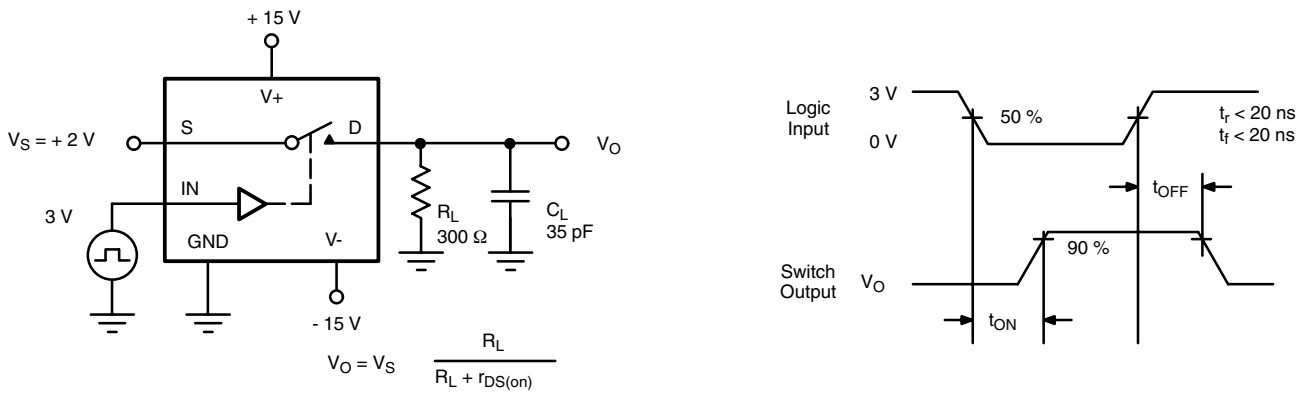

Figure 2. Switching Time

TEST CIRCUITS



C_L (includes fixture and stray capacitance)

Figure 3. Break-Before-Make



Figure 4. Off Isolation

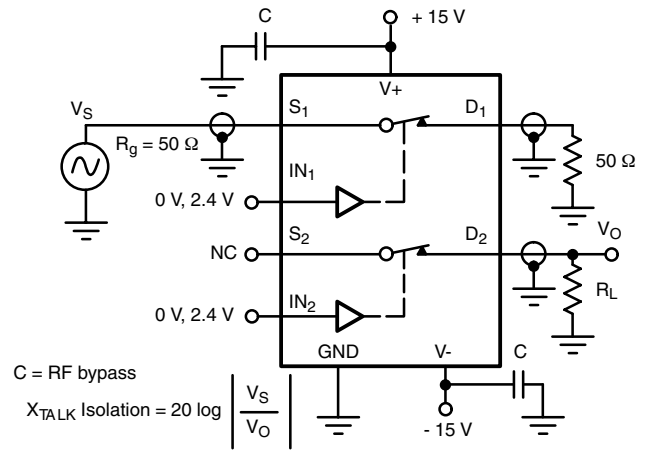

Figure 5. Channel-to-Channel Crosstalk

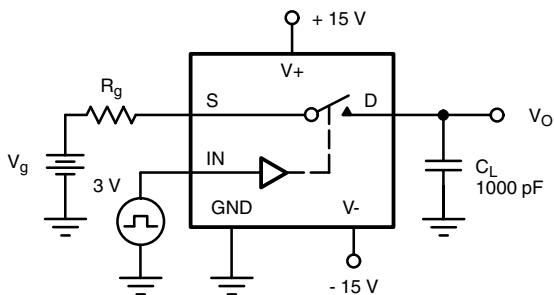
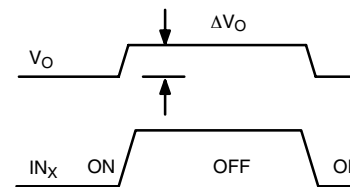

Figure 6. Charge Injection



ΔV_O = measured voltage error due to charge injection
The charge injection in coulombs is $Q = C_L \times \Delta V_O$

APPLICATIONS

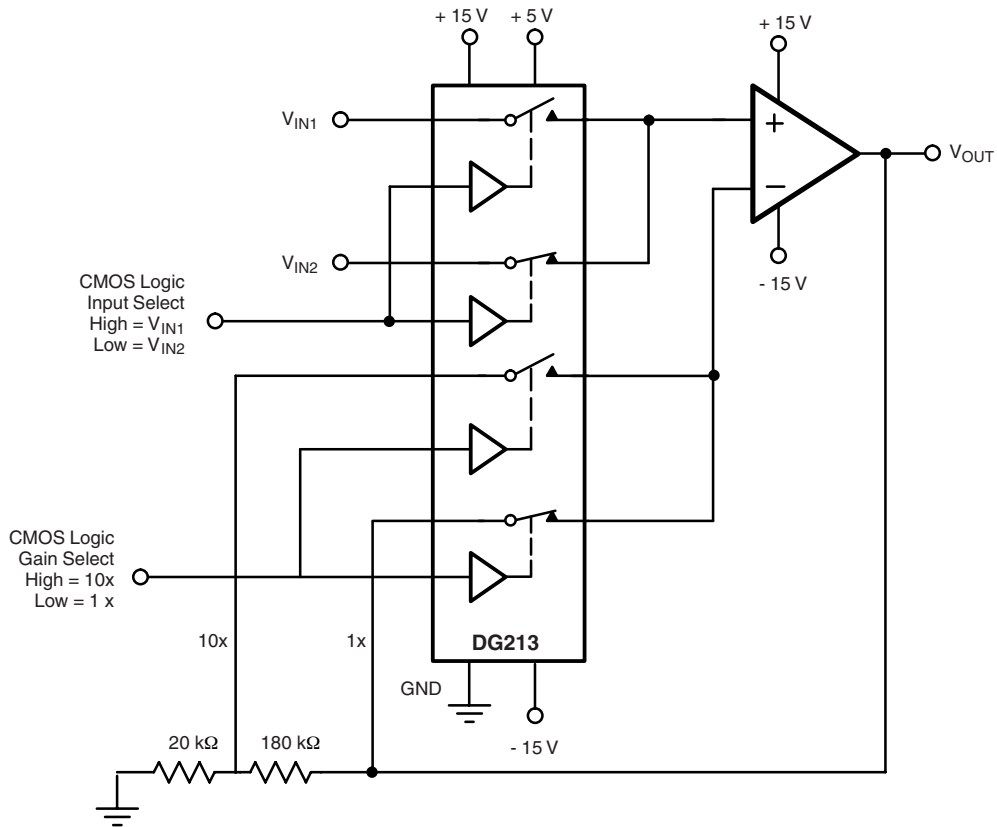

Figure 7. Low Power Non-Inverting Amplifier with Digitally Selectable Inputs and Gain

Vishay Siliconix maintains worldwide manufacturing capability. Products may be manufactured at one of several qualified locations. Reliability data for Silicon Technology and Package Reliability represent a composite of all qualified locations. For related documents such as package/tape drawings, part marking, and reliability data, see <http://www.vishay.com/ppg?70662>.



SOIC (NARROW): 16-LEAD
JEDEC Part Number: MS-012



Dim	MILLIMETERS		INCHES	
	Min	Max	Min	Max
A	1.35	1.75	0.053	0.069
A ₁	0.10	0.20	0.004	0.008
B	0.38	0.51	0.015	0.020
C	0.18	0.23	0.007	0.009
D	9.80	10.00	0.385	0.393
E	3.80	4.00	0.149	0.157
e	1.27 BSC		0.050 BSC	
H	5.80	6.20	0.228	0.244
L	0.50	0.93	0.020	0.037
∅	0°	8°	0°	8°

ECN: S-03946—Rev. F, 09-Jul-01
DWG: 5300

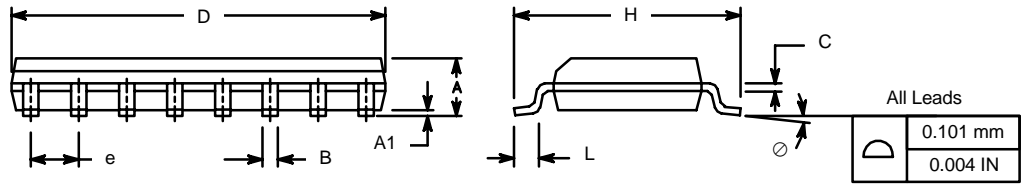

PDIP: 16-LEAD

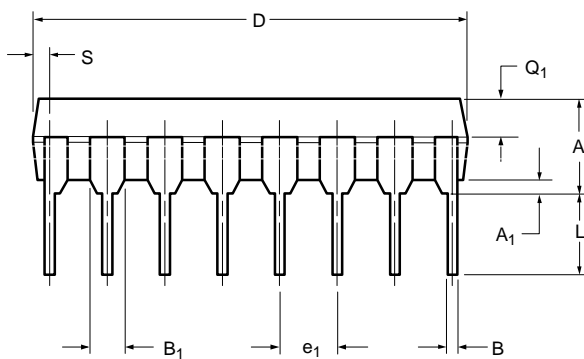

Dim	MILLIMETERS		INCHES	
	Min	Max	Min	Max
A	3.81	5.08	0.150	0.200
A₁	0.38	1.27	0.015	0.050
B	0.38	0.51	0.015	0.020
B₁	0.89	1.65	0.035	0.065
C	0.20	0.30	0.008	0.012
D	18.93	21.33	0.745	0.840
E	7.62	8.26	0.300	0.325
E₁	5.59	7.11	0.220	0.280
e₁	2.29	2.79	0.090	0.110
e_A	7.37	7.87	0.290	0.310
L	2.79	3.81	0.110	0.150
Q₁	1.27	2.03	0.050	0.080
S	0.38	1.52	.015	0.060

ECN: S-03946—Rev. D, 09-Jul-01
DWG: 5482

TSSOP: 16-LEAD

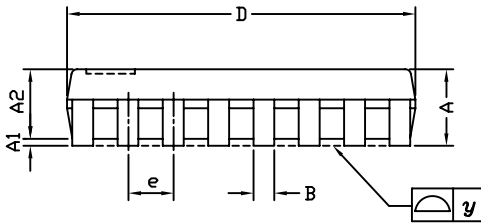

Symbols	DIMENSIONS IN MILLIMETERS		
	Min	Nom	Max
A	-	1.10	1.20
A1	0.05	0.10	0.15
A2	-	1.00	1.05
B	0.22	0.28	0.38
C	-	0.127	-
D	4.90	5.00	5.10
E	6.10	6.40	6.70
E1	4.30	4.40	4.50
e	-	0.65	-
L	0.50	0.60	0.70
L1	0.90	1.00	1.10
y	-	-	0.10
theta1	0°	3°	6°

ECN: S-61920-Rev. D, 23-Oct-06
DWG: 5624



RECOMMENDED MINIMUM PAD FOR TSSOP-16

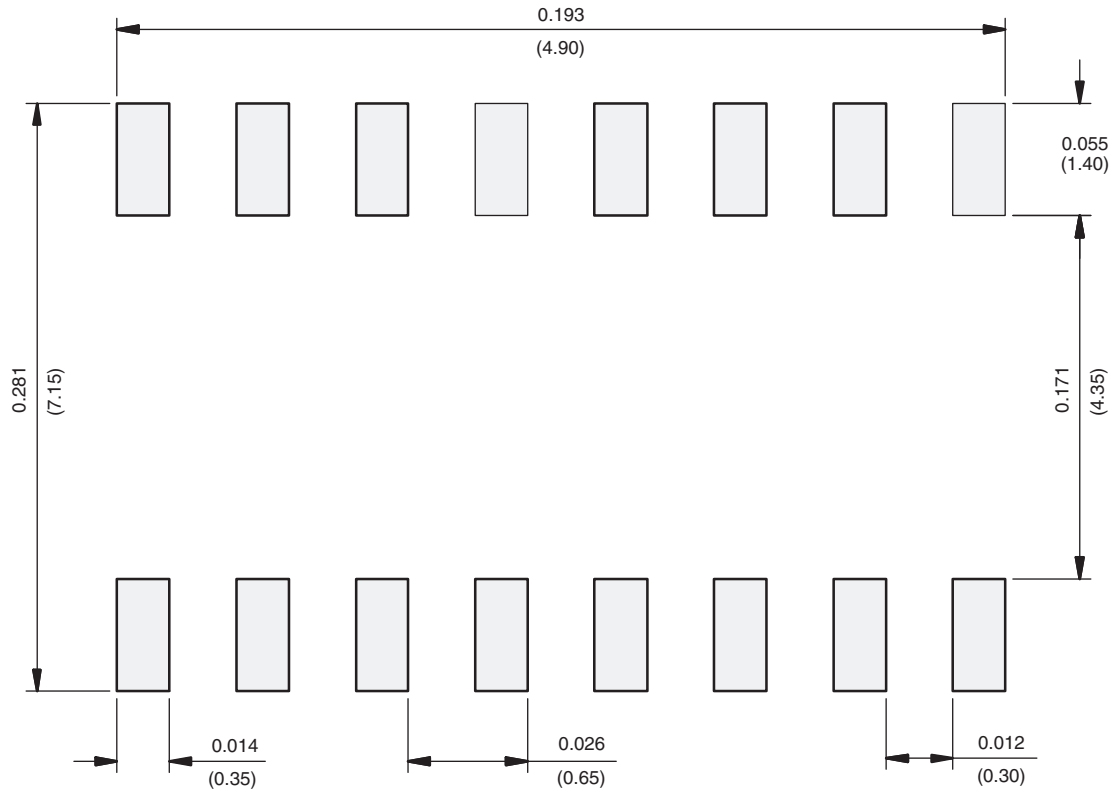

Recommended Minimum Pads
Dimensions in inches (mm)

RECOMMENDED MINIMUM PADS FOR SO-16



Recommended Minimum Pads
Dimensions in Inches/(mm)

[Return to Index](#)



Disclaimer

ALL PRODUCT, PRODUCT SPECIFICATIONS AND DATA ARE SUBJECT TO CHANGE WITHOUT NOTICE TO IMPROVE RELIABILITY, FUNCTION OR DESIGN OR OTHERWISE.

Vishay Intertechnology, Inc., its affiliates, agents, and employees, and all persons acting on its or their behalf (collectively, "Vishay"), disclaim any and all liability for any errors, inaccuracies or incompleteness contained in any datasheet or in any other disclosure relating to any product.

Vishay makes no warranty, representation or guarantee regarding the suitability of the products for any particular purpose or the continuing production of any product. To the maximum extent permitted by applicable law, Vishay disclaims (i) any and all liability arising out of the application or use of any product, (ii) any and all liability, including without limitation special, consequential or incidental damages, and (iii) any and all implied warranties, including warranties of fitness for particular purpose, non-infringement and merchantability.

Statements regarding the suitability of products for certain types of applications are based on Vishay's knowledge of typical requirements that are often placed on Vishay products in generic applications. Such statements are not binding statements about the suitability of products for a particular application. It is the customer's responsibility to validate that a particular product with the properties described in the product specification is suitable for use in a particular application. Parameters provided in datasheets and / or specifications may vary in different applications and performance may vary over time. All operating parameters, including typical parameters, must be validated for each customer application by the customer's technical experts. Product specifications do not expand or otherwise modify Vishay's terms and conditions of purchase, including but not limited to the warranty expressed therein.

Except as expressly indicated in writing, Vishay products are not designed for use in medical, life-saving, or life-sustaining applications or for any other application in which the failure of the Vishay product could result in personal injury or death. Customers using or selling Vishay products not expressly indicated for use in such applications do so at their own risk. Please contact authorized Vishay personnel to obtain written terms and conditions regarding products designed for such applications.

No license, express or implied, by estoppel or otherwise, to any intellectual property rights is granted by this document or by any conduct of Vishay. Product names and markings noted herein may be trademarks of their respective owners.



Стандарт Электрон Связь

Мы молодая и активно развивающаяся компания в области поставок электронных компонентов. Мы поставляем электронные компоненты отечественного и импортного производства напрямую от производителей и с крупнейших складов мира.

Благодаря сотрудничеству с мировыми поставщиками мы осуществляем комплексные и плановые поставки широчайшего спектра электронных компонентов.

Собственная эффективная логистика и склад в обеспечивает надежную поставку продукции в точно указанные сроки по всей России.

Мы осуществляем техническую поддержку нашим клиентам и предпродажную проверку качества продукции. На все поставляемые продукты мы предоставляем гарантию .

Осуществляем поставки продукции под контролем ВП МО РФ на предприятия военно-промышленного комплекса России , а также работаем в рамках 275 ФЗ с открытием отдельных счетов в уполномоченном банке. Система менеджмента качества компании соответствует требованиям ГОСТ ISO 9001.

Минимальные сроки поставки, гибкие цены, неограниченный ассортимент и индивидуальный подход к клиентам являются основой для выстраивания долгосрочного и эффективного сотрудничества с предприятиями радиоэлектронной промышленности, предприятиями ВПК и научно-исследовательскими институтами России.

С нами вы становитесь еще успешнее!

Наши контакты:

Телефон: +7 812 627 14 35

Электронная почта: sales@st-electron.ru

Адрес: 198099, Санкт-Петербург,
Промышленная ул, дом № 19, литера Н,
помещение 100-Н Офис 331