

# RF Power LDMOS Transistors

## N-Channel Enhancement-Mode Lateral MOSFETs

These 50 W asymmetrical Doherty RF power LDMOS transistors are designed for cellular base station applications requiring very wide instantaneous bandwidth capability covering the frequency range of 2496 to 2690 MHz.

- Typical Doherty Single-Carrier W-CDMA Performance:  $V_{DD} = 28$  Vdc,  $I_{DQA} = 700$  mA,  $V_{GSB} = 0.4$  Vdc,  $P_{out} = 50$  W Avg., Input Signal PAR = 9.9 dB @ 0.01% Probability on CCDF.

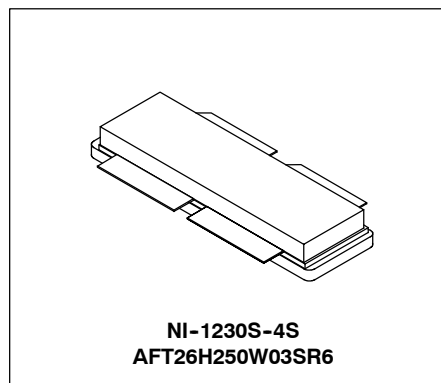
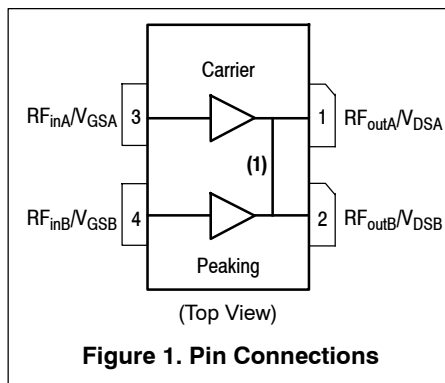
Frequency	$G_{ps}$ (dB)	$\eta_D$ (%)	Output PAR (dB)	ACPR (dBc)
2496 MHz	14.1	44.6	8.1	-31.5
2590 MHz	14.4	44.9	8.1	-33.8
2690 MHz	14.2	44.2	7.9	-37.6

**AFT26H250W03SR6**  
**AFT26H250-24SR6**

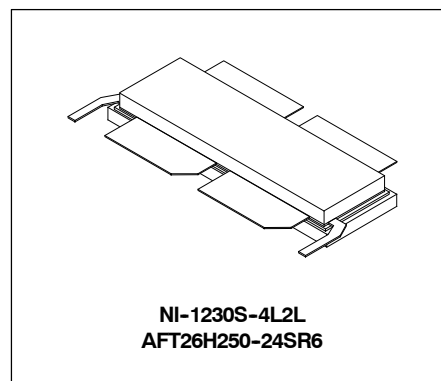
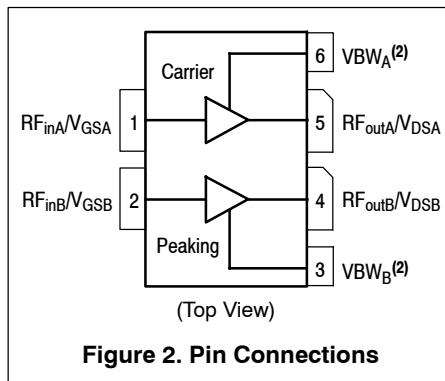
**2496–2690 MHz, 50 W AVG., 28 V**  
**AIRFAST RF POWER LDMOS**  
**TRANSISTORS**

### Features

- Advanced High Performance In-Package Doherty
- Designed for Wide Instantaneous Bandwidth Applications (AFT26H250W03S)
- Greater Negative Gate-Source Voltage Range for Improved Class C Operation
- Designed for Digital Predistortion Error Correction Systems
- In Tape and Reel. R6 Suffix = 150 Units, 56 mm Tape Width, 13-inch Reel.



1. Pin connections 1 and 2 are DC coupled and RF independent.



2. Device cannot operate with the  $V_{DD}$  current supplied through pin 3 and pin 6.

**Table 1. Maximum Ratings**

Rating	Symbol	Value	Unit
Drain-Source Voltage	$V_{DSS}$	-0.5, +65	Vdc
Gate-Source Voltage	$V_{GS}$	-6.0, +10	Vdc
Operating Voltage	$V_{DD}$	32, +0	Vdc
Storage Temperature Range	$T_{stg}$	-65 to +150	°C
Case Operating Temperature Range	AFT26H250W03S AFT26H250-24S	$T_C$ -40 to +125 -40 to +150	°C
Operating Junction Temperature Range (1,2)	$T_J$	-40 to +225	°C
CW Operation @ $T_C = 25^\circ\text{C}$ Derate above $25^\circ\text{C}$	CW	294 1.7	W W/°C

**Table 2. Thermal Characteristics**

Characteristic	Symbol	Value (2,3)	Unit
Thermal Resistance, Junction to Case Case Temperature $78^\circ\text{C}$ , 50 W-CDMA, 28 Vdc, $I_{DQA} = 700\text{ mA}$ , $V_{GSB} = 0.4\text{ Vdc}$ , 2590 MHz	$R_{\theta JC}$	0.42	°C/W

**Table 3. ESD Protection Characteristics**

Test Methodology	Class
Human Body Model (per JESD22-A114)	2
Machine Model (per EIA/JESD22-A115)	B
Charge Device Model (per JESD22-C101)	IV

**Table 4. Electrical Characteristics** ( $T_A = 25^\circ\text{C}$  unless otherwise noted)

Characteristic	Symbol	Min	Typ	Max	Unit
----------------	--------	-----	-----	-----	------

**Off Characteristics**

Zero Gate Voltage Drain Leakage Current ( $V_{DS} = 65\text{ Vdc}$ , $V_{GS} = 0\text{ Vdc}$ )	AFT26H250W03S (4,5) AFT26H250-24S (6)	$I_{DSS}$	—	—	10	$\mu\text{A}$ dc
Zero Gate Voltage Drain Leakage Current ( $V_{DS} = 28\text{ Vdc}$ , $V_{GS} = 0\text{ Vdc}$ )	AFT26H250W03S (4,5) AFT26H250-24S (6)	$I_{DSS}$	—	—	5 1	$\mu\text{A}$ dc
Gate-Source Leakage Current ( $V_{GS} = 5\text{ Vdc}$ , $V_{DS} = 0\text{ Vdc}$ )	AFT26H250W03S (4,5) AFT26H250-24S (6)	$I_{GSS}$	—	—	1	$\mu\text{A}$ dc

**On Characteristics - Side A (Carrier)**

Gate Threshold Voltage ( $V_{DS} = 10\text{ Vdc}$ , $I_D = 140\ \mu\text{A}$ dc)	AFT26H250W03S (4,6) AFT26H250-24S (6)	$V_{GS(th)}$	0.8	1.2	1.6	Vdc
Gate Quiescent Voltage ( $V_{DD} = 28\text{ Vdc}$ , $I_{DA} = 700\text{ mA}$ dc, Measured in Functional Test)	AFT26H250W03S (4,6) AFT26H250-24S (6)	$V_{GS(Q)}$	1.4	1.8	2.2	Vdc
Drain-Source On-Voltage ( $V_{GS} = 6\text{ Vdc}$ , $I_D = 1.4\text{ A}$ dc)	AFT26H250W03S (4,6) AFT26H250-24S (6)	$V_{DS(on)}$	0.1	0.15	0.3	Vdc

**On Characteristics - Side B (Peaking)**

Gate Threshold Voltage ( $V_{DS} = 10\text{ Vdc}$ , $I_D = 200\ \mu\text{A}$ dc)	AFT26H250W03S (4,6) AFT26H250-24S (6)	$V_{GS(th)}$	0.8	1.2	1.6	Vdc
Drain-Source On-Voltage ( $V_{GS} = 6\text{ Vdc}$ , $I_D = 2.0\text{ A}$ dc)	AFT26H250W03S (4,6) AFT26H250-24S (6)	$V_{DS(on)}$	0.1	0.15	0.3	Vdc

1. Continuous use at maximum temperature will affect MTTF.
2. MTTF calculator available at <http://www.freescale.com/rf>. Select Software & Tools/Development Tools/Calculators to access MTTF calculators by product.
3. Refer to AN1955, *Thermal Measurement Methodology of RF Power Amplifiers*. Go to <http://www.freescale.com/rf>. Select Documentation/Application Notes - AN1955.
4.  $V_{DDA}$  and  $V_{ddb}$  must be tied together and powered by a single DC power supply.
5. Side A and Side B are tied together for these measurements.
6. Each side of device measure separately.

(continued)

**Table 4. Electrical Characteristics** ( $T_A = 25^\circ\text{C}$  unless otherwise noted) (continued)

Characteristic	Symbol	Min	Typ	Max	Unit
<b>Functional Tests</b> <sup>(1,2,3)</sup> (In Freescale Doherty Test Fixture, 50 ohm system) $V_{DD} = 28\text{ Vdc}$ , $I_{DQA} = 700\text{ mA}$ , $V_{GSB} = 0.4\text{ Vdc}$ , $P_{out} = 50\text{ W Avg.}$ , $f = 2496\text{ MHz}$ , Single-Carrier W-CDMA, IQ Magnitude Clipping, Input Signal PAR = 9.9 dB @ 0.01% Probability on CCDF. ACPR measured in 3.84 MHz Channel Bandwidth @ $\pm 5\text{ MHz}$ Offset.					
Power Gain	$G_{ps}$	13.0	14.1	16.0	dB
Drain Efficiency	$\eta_D$	41.0	44.6	—	%
Output Peak-to-Average Ratio @ 0.01% Probability on CCDF AFT26H250W03S AFT26H250-24S	PAR	7.5 7.4	8.1 8.1	— —	dB
Adjacent Channel Power Ratio	ACPR	—	-31.5	-29.0	dBc

**Load Mismatch — AFT26H250W03S** (In Freescale Test Fixture, 50 ohm system)  $I_{DQA} = 700\text{ mA}$ ,  $f = 2590\text{ MHz}$ 

VSWR 10:1 at 32 Vdc, 364 W <sup>(4)</sup> CW Output Power (3 dB Input Overdrive from 230 W CW Rated Power)	No Device Degradation
---	-----------------------

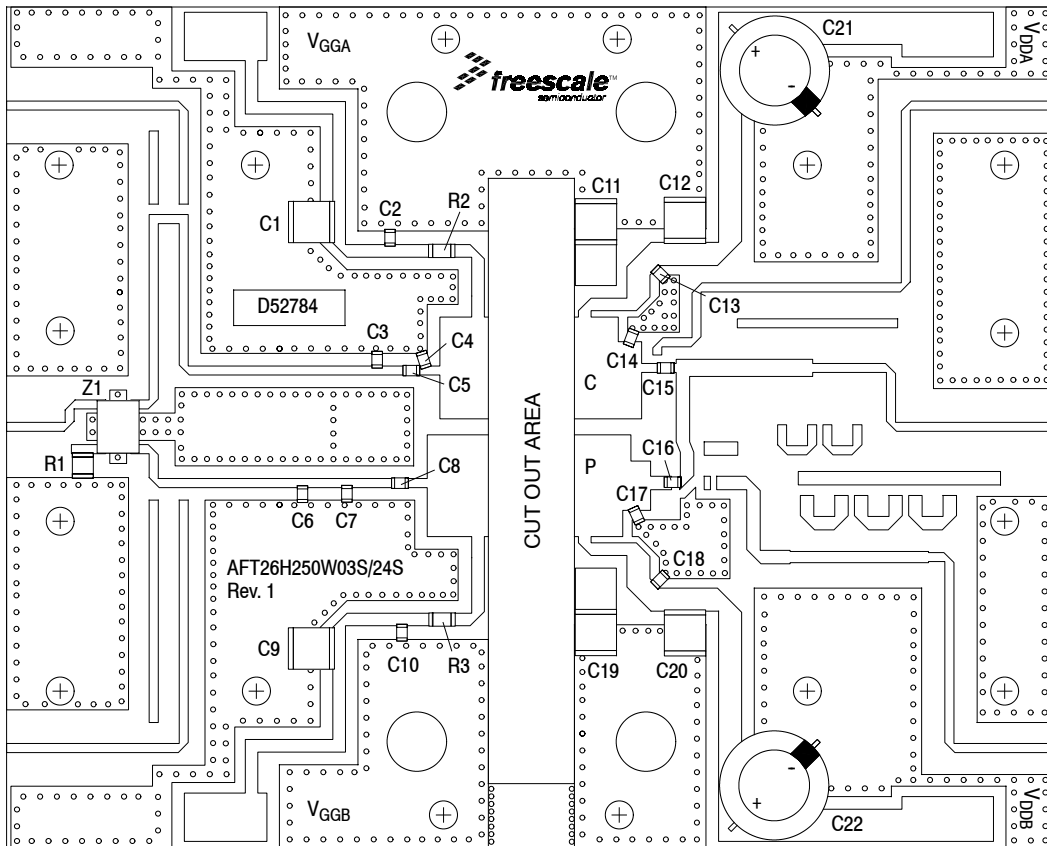
**Load Mismatch — AFT26H250-24S** (In Freescale Test Fixture, 50 ohm system)  $I_{DQA} = 700\text{ mA}$ ,  $f = 2590\text{ MHz}$ 

VSWR 10:1 at 32 Vdc, 335 W <sup>(4)</sup> CW Output Power (2 dB Input Overdrive from 230 W CW Rated Power)	No Device Degradation
---	-----------------------

**Typical Performances** <sup>(2)</sup> (In Freescale Doherty Test Fixture, 50 ohm system)  $V_{DD} = 28\text{ Vdc}$ ,  $I_{DQA} = 700\text{ mA}$ ,  $V_{GSB} = 0.4\text{ Vdc}$ , 2496-2690 MHz Bandwidth

$P_{out}$ @ 1 dB Compression Point, CW	P1dB	—	230	—	W
$P_{out}$ @ 3 dB Compression Point <sup>(5)</sup>	P3dB	—	320	—	W
AM/PM (Maximum value measured at the P3dB compression point across the 2496-2690 MHz frequency range)	$\Phi$	—	-22	—	°
VBW Resonance Point (IMD Third Order Intermodulation Inflection Point)	VBW <sub>res</sub>	—	140 110	—	MHz
AFT26H250W03S AFT26H250-24S					
Gain Flatness in 194 MHz Bandwidth @ $P_{out} = 50\text{ W Avg.}$	$G_F$	—	0.3	—	dB
Gain Variation over Temperature (-30°C to +85°C)	$\Delta G$	—	0.002	—	dB/°C
Output Power Variation over Temperature (-30°C to +85°C) <sup>(4)</sup>	$\Delta P1dB$	—	0.006	—	dB/°C

- Part internally matched both on input and output.
- $V_{DDA}$  and  $V_{DDB}$  must be tied together and powered by a single DC power supply (AFT26H250W03S).
- Measurements made with device in an asymmetrical Doherty configuration.
- Exceeds recommended operating conditions. See CW operation data in Maximum Ratings table.
- $P3dB = P_{avg} + 7.0\text{ dB}$  where  $P_{avg}$  is the average output power measured using an unclipped W-CDMA single-carrier input signal where output PAR is compressed to 7.0 dB @ 0.01% probability on CCDF.



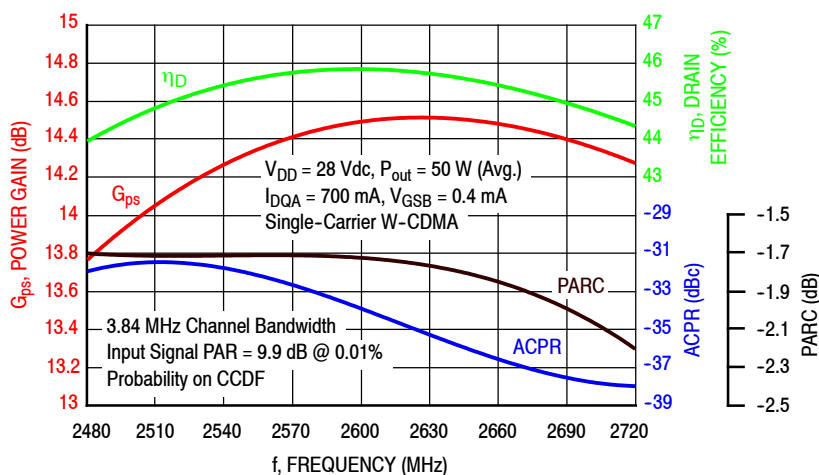
Note:  $V_{DDA}$  and  $V_{ddb}$  must be tied together and powered by a single DC power supply.

**Figure 3. AFT26H250W03SR6(-24SR6) Test Circuit Component Layout**

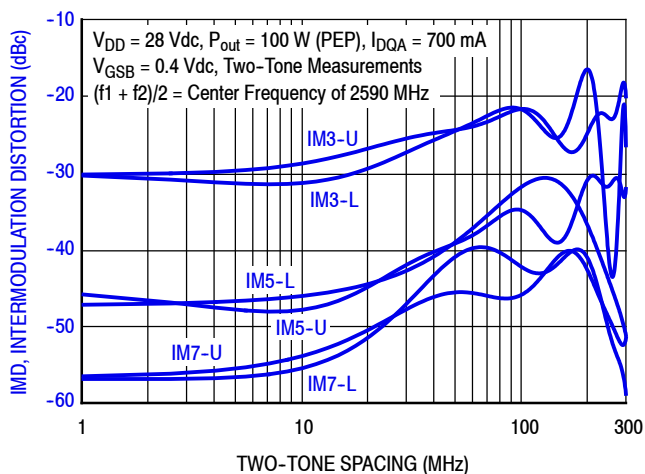
**Table 5. AFT26H250W03SR6(-24SR6) Test Circuit Component Designations and Values**

Part	Description	Part Number	Manufacturer
C1, C9, C11, C12, C19, C20	10 $\mu$ F Chip Capacitors	C5750X7S2A106M230KB	TDK
C2, C5, C8, C10, C13, C18	6.8 pF Chip Capacitors	ATC600F6R8BT250XT	ATC
C3, C4	0.5 pF Chip Capacitors	ATC600F0R5BT250XT	ATC
C6, C7	0.3 pF Chip Capacitors	ATC600F0R3BT250XT	ATC
C14	0.8 pF Chip Capacitor	ATC600F0R8BT250XT	ATC
C15	2.0 pF Chip Capacitor	ATC600F2R0BT250XT	ATC
C16	10 pF Chip Capacitor	ATC600F100JT250XT	ATC
C17	0.9 pF Chip Capacitor	ATC600F0R9BT250XT	ATC
C21, C22	220 $\mu$ F Electrolytic Capacitors	227CKS050M	Illinois Capacitor
R1	50 $\Omega$ , 4 W Chip Resistor	CW12010T0050GBK	ATC
R2, R3	2.0 $\Omega$ , 1/4 W Chip Resistors	CRCW12062R00JNEA	Vishay
Z1	2300–2700 MHz Band, 5 dB Directional Coupler	X3C25P1-05S	Anaren
PCB	Rogers RO4305B, 0.020", $\epsilon_r = 3.66$	D52784	MTL

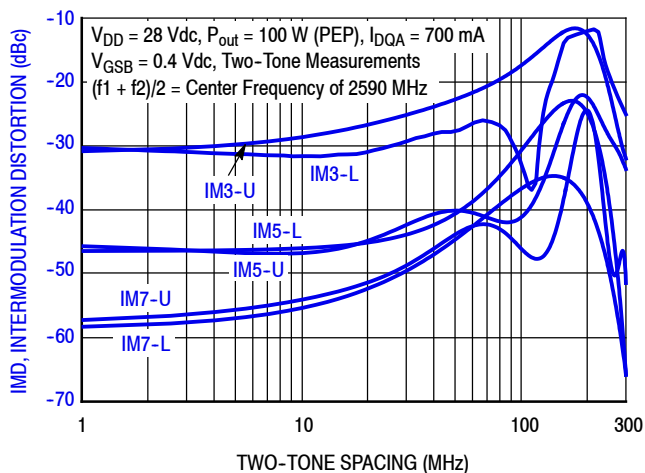
### TYPICAL CHARACTERISTICS



**Figure 4. Single-Carrier Output Peak-to-Average Ratio Compression (PARC) Broadband Performance @  $P_{out} = 50$  Watts Avg.**

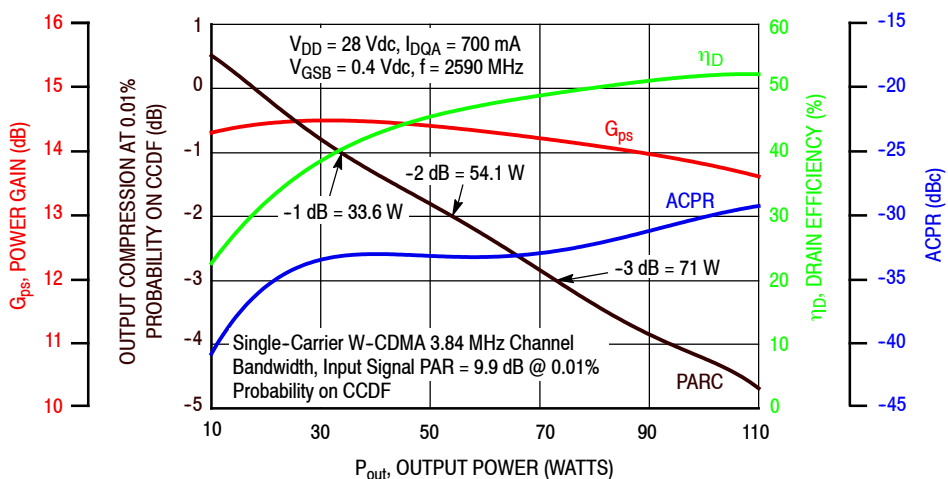


**Figure 5. Intermodulation Distortion Products versus Two-Tone Spacing — AFT26H250W03S**

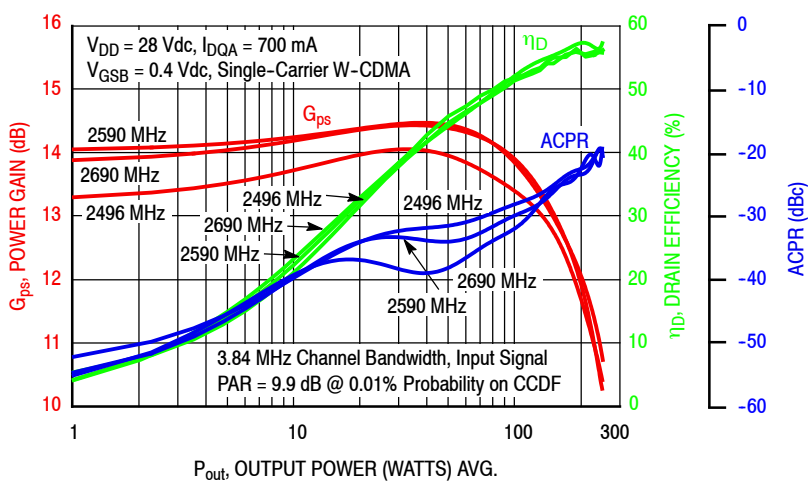


**Figure 6. Intermodulation Distortion Products versus Two-Tone Spacing — AFT26H250-24S**

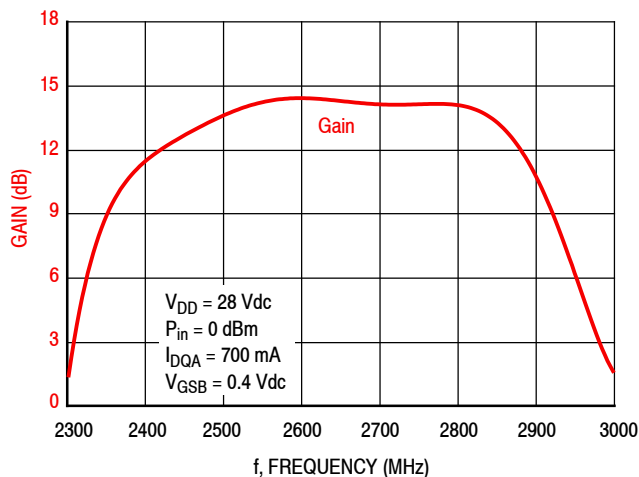
### TYPICAL CHARACTERISTICS



**Figure 7. Output Peak-to-Average Ratio Compression (PARC) versus Output Power**



**Figure 8. Single-Carrier W-CDMA Power Gain, Drain Efficiency and ACPR versus Output Power**



**Figure 9. Broadband Frequency Response**

$V_{DD} = 28 \text{ Vdc}$ ,  $I_{DQA} = 689 \text{ mA}$ , Pulsed CW, 10  $\mu\text{sec(ON)}$ , 10% Duty Cycle

f (MHz)	$Z_{\text{source}} (\Omega)$	$Z_{\text{in}} (\Omega)$	Max Output Power					
			P1dB					
			$Z_{\text{load}}^{(1)} (\Omega)$	Gain (dB)	(dBm)	(W)	$\eta_D$ (%)	AM/PM (°)
2496	4.07 - j10.7	4.00 + j9.61	2.03 - j4.57	17.4	51.8	151	54.1	-13
2590	7.57 - j11.9	6.72 + j10.7	2.00 - j4.75	17.6	51.7	147	53.2	-12
2690	15.7 - j9.50	12.9 + j8.73	2.00 - j5.11	17.6	51.6	143	52.4	-13

f (MHz)	$Z_{\text{source}} (\Omega)$	$Z_{\text{in}} (\Omega)$	Max Output Power					
			P3dB					
			$Z_{\text{load}}^{(2)} (\Omega)$	Gain (dB)	(dBm)	(W)	$\eta_D$ (%)	AM/PM (°)
2496	4.07 - j10.7	3.92 + j10.2	1.92 - j4.78	15.2	52.5	179	54.9	-17
2590	7.57 - j11.9	7.03 + j11.7	1.91 - j4.97	15.3	52.4	174	53.6	-17
2690	15.7 - j9.50	14.9 + j9.37	1.92 - j5.34	15.3	52.3	170	52.4	-17

(1) Load impedance for optimum P1dB power.

(2) Load impedance for optimum P3dB power.

$Z_{\text{source}}$  = Measured impedance presented to the input of the device at the package reference plane.

$Z_{\text{in}}$  = Impedance as measured from gate contact to ground.

$Z_{\text{load}}$  = Measured impedance presented to the output of the device at the package reference plane.

**Figure 10. Carrier Side Load Pull Performance — Maximum Power Tuning**

$V_{DD} = 28 \text{ Vdc}$ ,  $I_{DQA} = 689 \text{ mA}$ , Pulsed CW, 10  $\mu\text{sec(ON)}$ , 10% Duty Cycle

f (MHz)	$Z_{\text{source}} (\Omega)$	$Z_{\text{in}} (\Omega)$	Max Drain Efficiency					
			P1dB					
			$Z_{\text{load}}^{(1)} (\Omega)$	Gain (dB)	(dBm)	(W)	$\eta_D$ (%)	AM/PM (°)
2496	4.07 - j10.7	4.07 + j10.0	4.82 - j3.58	19.7	49.9	97	64.0	-19
2590	7.57 - j11.9	6.62 + j11.4	3.74 - j2.51	20.0	49.6	92	62.6	-21
2690	15.7 - j9.50	13.3 + j9.45	3.36 - j2.87	19.9	49.5	90	61.2	-20

f (MHz)	$Z_{\text{source}} (\Omega)$	$Z_{\text{in}} (\Omega)$	Max Drain Efficiency					
			P3dB					
			$Z_{\text{load}}^{(2)} (\Omega)$	Gain (dB)	(dBm)	(W)	$\eta_D$ (%)	AM/PM (°)
2496	4.07 - j10.7	3.77 + j10.6	4.53 - j2.90	17.8	50.4	111	64.0	-28
2590	7.57 - j11.9	6.80 + j12.2	3.67 - j2.58	18.0	50.3	108	62.7	-29
2690	15.7 - j9.50	15.2 + j9.96	3.36 - j2.87	17.9	50.2	105	61.2	-28

(1) Load impedance for optimum P1dB efficiency.

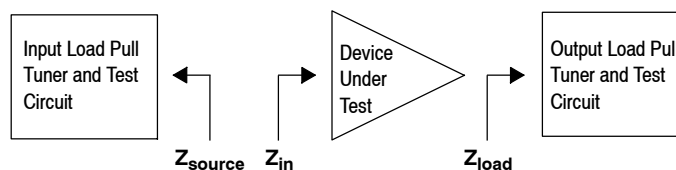
(2) Load impedance for optimum P3dB efficiency.

$Z_{\text{source}}$  = Measured impedance presented to the input of the device at the package reference plane.

$Z_{\text{in}}$  = Impedance as measured from gate contact to ground.

$Z_{\text{load}}$  = Measured impedance presented to the output of the device at the package reference plane.

**Figure 11. Carrier Side Load Pull Performance — Maximum Drain Efficiency Tuning**



$V_{DD} = 28 \text{ Vdc}$ ,  $V_{GSB} = 0.4 \text{ mA}$ , Pulsed CW, 10  $\mu\text{sec(on)}$ , 10% Duty Cycle

f (MHz)	$Z_{\text{source}} (\Omega)$	$Z_{\text{in}} (\Omega)$	Max Output Power					
			P1dB					
			$Z_{\text{load}}^{(1)} (\Omega)$	Gain (dB)	(dBm)	(W)	$\eta_D$ (%)	AM/PM (°)
2496	3.33 - j9.36	3.00 + j9.43	2.00 - j5.09	12.1	53.2	209	54.4	-22
2590	4.98 - j10.4	5.22 + j10.6	2.11 - j5.43	12.2	53.1	203	53.8	-22
2690	10.9 - j8.12	11.3 + j9.48	2.35 - j6.10	12.1	52.9	196	52.8	-20

f (MHz)	$Z_{\text{source}} (\Omega)$	$Z_{\text{in}} (\Omega)$	Max Output Power					
			P3dB					
			$Z_{\text{load}}^{(2)} (\Omega)$	Gain (dB)	(dBm)	(W)	$\eta_D$ (%)	AM/PM (°)
2496	3.33 - j9.36	3.14 + j9.86	1.99 - j5.35	9.9	53.9	243	54.3	-28
2590	4.98 - j10.4	5.76 + j11.2	2.11 - j5.74	10.0	53.7	236	53.0	-28
2690	10.9 - j8.12	13.0 + j9.24	2.40 - j6.29	10.0	53.5	226	52.5	-26

(1) Load impedance for optimum P1dB power.

(2) Load impedance for optimum P3dB power.

$Z_{\text{source}}$  = Measured impedance presented to the input of the device at the package reference plane.

$Z_{\text{in}}$  = Impedance as measured from gate contact to ground.

$Z_{\text{load}}$  = Measured impedance presented to the output of the device at the package reference plane.

**Figure 12. Peaking Side Load Pull Performance — Maximum Power Tuning**

$V_{DD} = 28 \text{ Vdc}$ ,  $V_{GSB} = 0.4 \text{ mA}$ , Pulsed CW, 10  $\mu\text{sec(on)}$ , 10% Duty Cycle

f (MHz)	$Z_{\text{source}} (\Omega)$	$Z_{\text{in}} (\Omega)$	Max Drain Efficiency					
			P1dB					
			$Z_{\text{load}}^{(1)} (\Omega)$	Gain (dB)	(dBm)	(W)	$\eta_D$ (%)	AM/PM (°)
2496	3.33 - j9.36	2.65 + j9.45	4.22 - j3.35	13.3	51.6	144	64.3	-30
2590	4.98 - j10.4	4.64 + j10.7	3.57 - j3.41	13.4	51.6	145	63.8	-30
2690	10.9 - j8.12	10.5 + j10.4	3.29 - j3.86	13.1	51.6	143	62.4	-27

f (MHz)	$Z_{\text{source}} (\Omega)$	$Z_{\text{in}} (\Omega)$	Max Drain Efficiency					
			P3dB					
			$Z_{\text{load}}^{(2)} (\Omega)$	Gain (dB)	(dBm)	(W)	$\eta_D$ (%)	AM/PM (°)
2496	3.33 - j9.36	2.81 + j9.82	3.97 - j3.62	11.2	52.3	171	64.6	-38
2590	4.98 - j10.4	5.16 + j11.3	3.50 - j3.54	11.3	52.2	167	63.7	-38
2690	10.9 - j8.12	12.3 + j10.3	3.17 - j3.92	11.1	52.1	163	61.8	-35

(1) Load impedance for optimum P1dB efficiency.

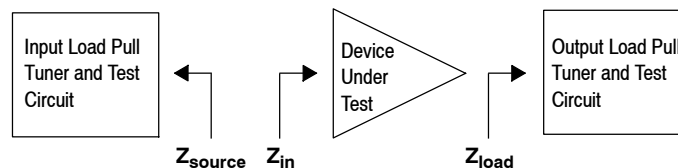
(2) Load impedance for optimum P3dB efficiency.

$Z_{\text{source}}$  = Measured impedance presented to the input of the device at the package reference plane.

$Z_{\text{in}}$  = Impedance as measured from gate contact to ground.

$Z_{\text{load}}$  = Measured impedance presented to the output of the device at the package reference plane.

**Figure 13. Peaking Side Load Pull Performance — Maximum Drain Efficiency Tuning**





### P1dB - TYPICAL CARRIER SIDE LOAD PULL CONTOURS — 2590 MHz

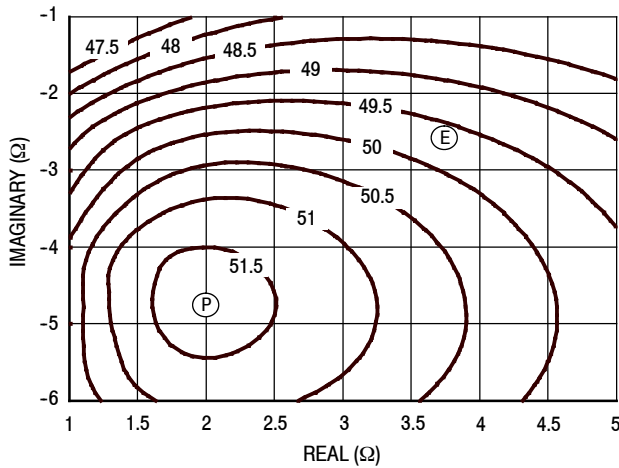


Figure 14. P1dB Load Pull Output Power Contours (dBm)

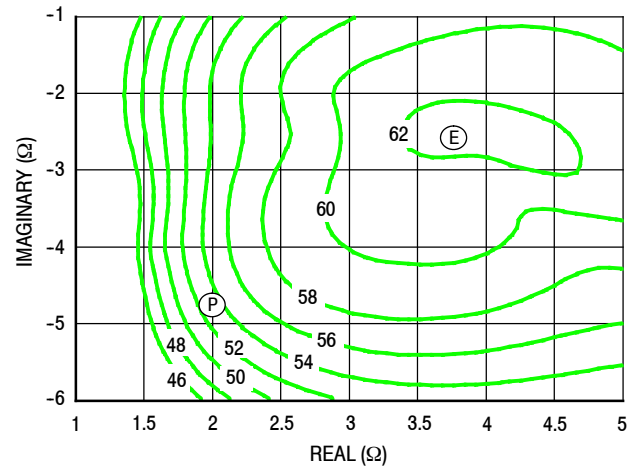


Figure 15. P1dB Load Pull Efficiency Contours (%)

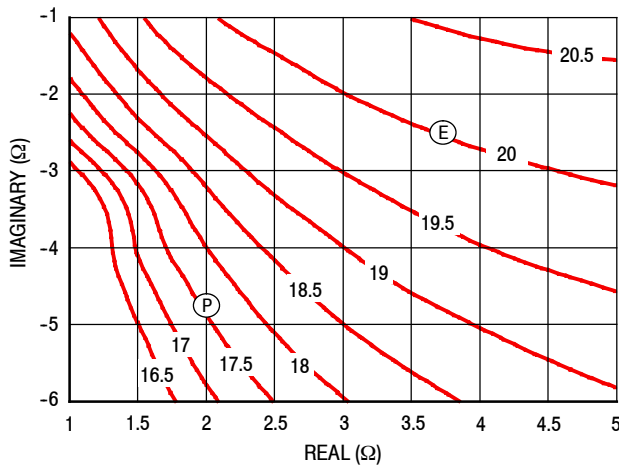


Figure 16. P1dB Load Pull Gain Contours (dB)

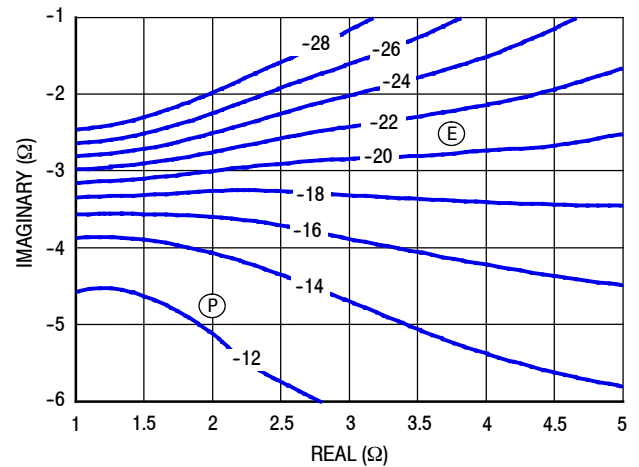


Figure 17. P1dB Load Pull AM/PM Contours (°)

**NOTE:** (P) = Maximum Output Power  
 (E) = Maximum Drain Efficiency

- Gain
- Drain Efficiency
- Linearity
- Output Power

### P3dB - TYPICAL CARRIER SIDE LOAD PULL CONTOURS — 2590 MHz

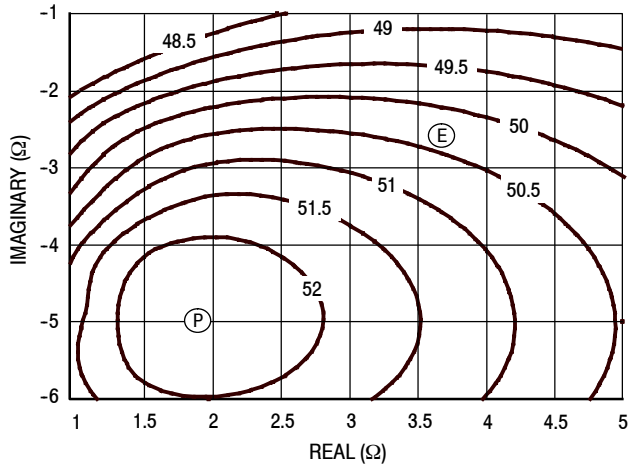


Figure 18. P3dB Load Pull Output Power Contours (dBm)

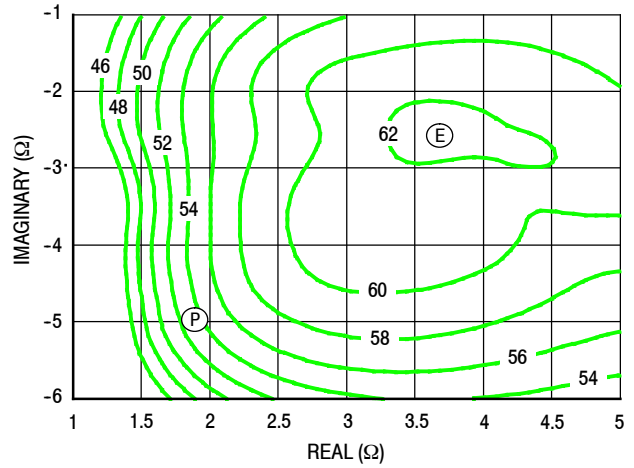


Figure 19. P3dB Load Pull Efficiency Contours (%)

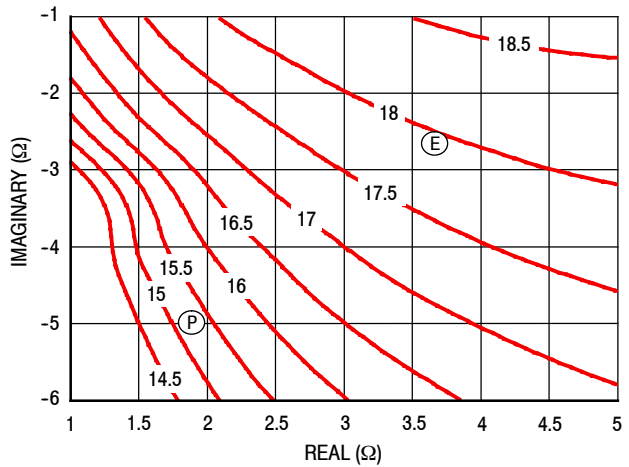


Figure 20. P3dB Load Pull Gain Contours (dB)

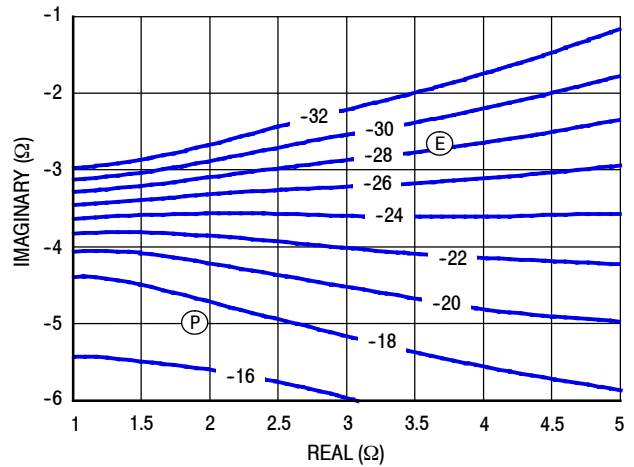


Figure 21. P3dB Load Pull AM/PM Contours (°)

**NOTE:** (P) = Maximum Output Power  
 (E) = Maximum Drain Efficiency

- Gain
- Drain Efficiency
- Linearity
- Output Power

### P1dB - TYPICAL PEAKING SIDE LOAD PULL CONTOURS — 2590 MHz

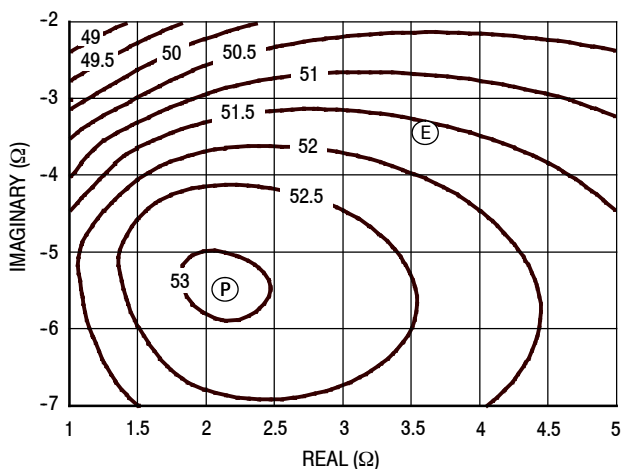


Figure 22. P1dB Load Pull Output Power Contours (dBm)

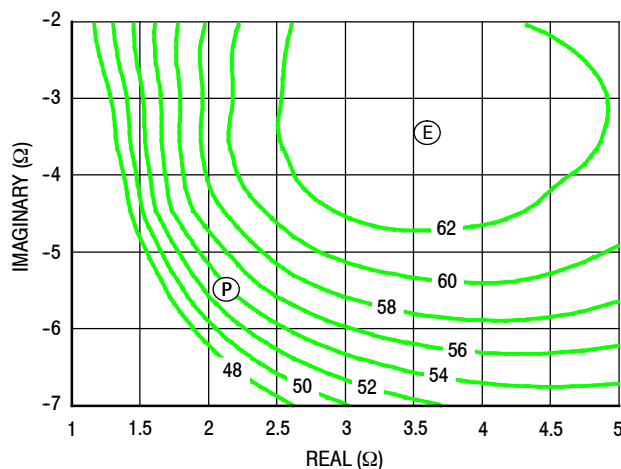


Figure 23. P1dB Load Pull Efficiency Contours (%)

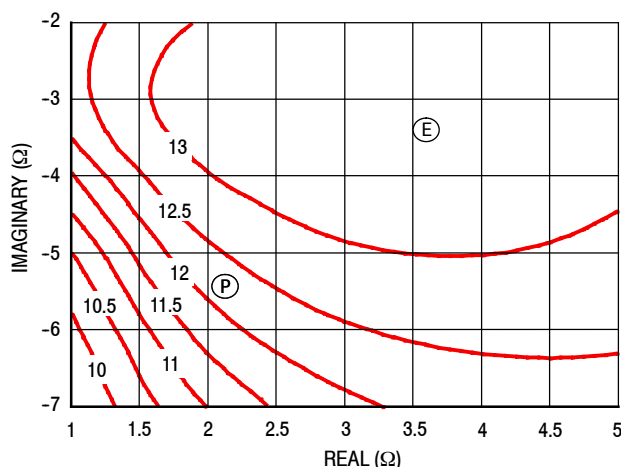


Figure 24. P1dB Load Pull Gain Contours (dB)

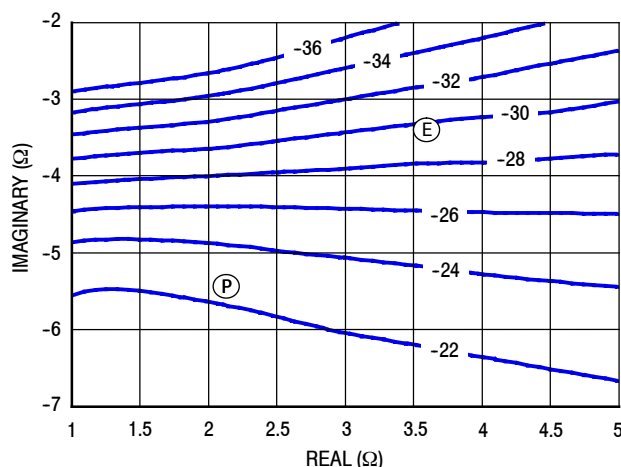


Figure 25. P1dB Load Pull AM/PM Contours (°)

**NOTE:** (P) = Maximum Output Power  
 (E) = Maximum Drain Efficiency

- Gain
- Drain Efficiency
- Linearity
- Output Power

### P3dB - TYPICAL PEAKING SIDE LOAD PULL CONTOURS — 2590 MHz

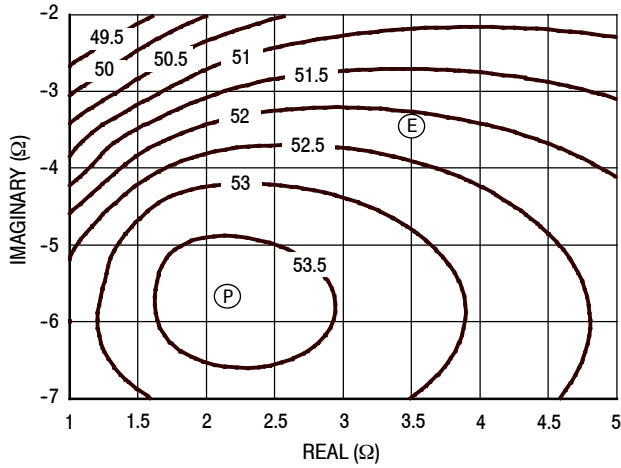


Figure 26. P3dB Load Pull Output Power Contours (dBm)

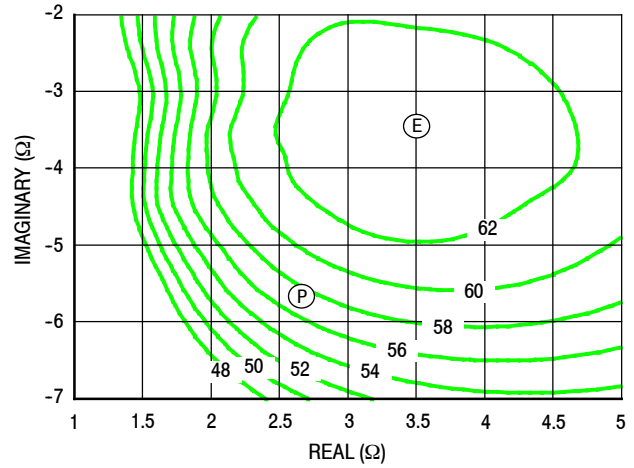


Figure 27. P3dB Load Pull Efficiency Contours (%)

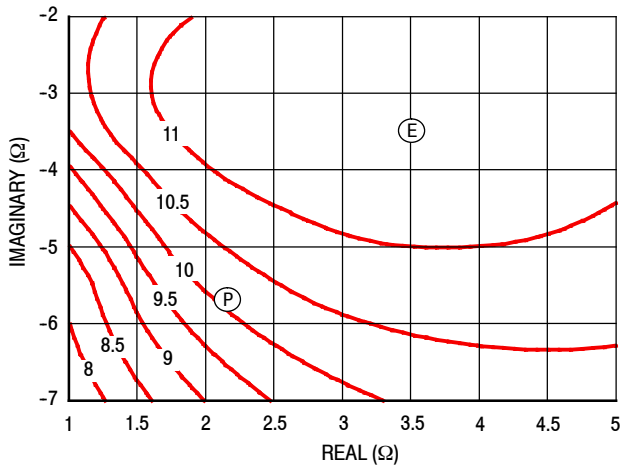


Figure 28. P3dB Load Pull Gain Contours (dB)

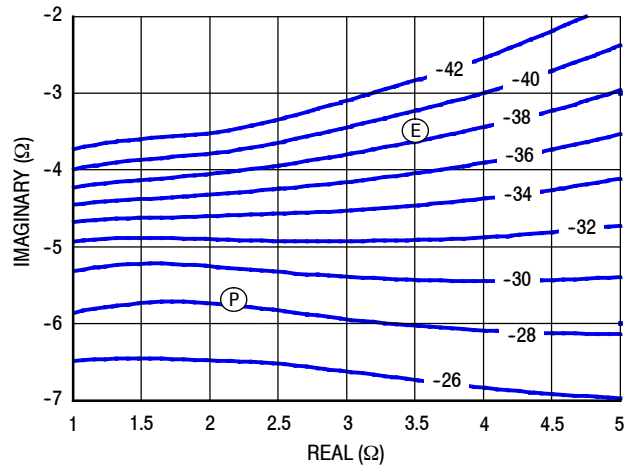
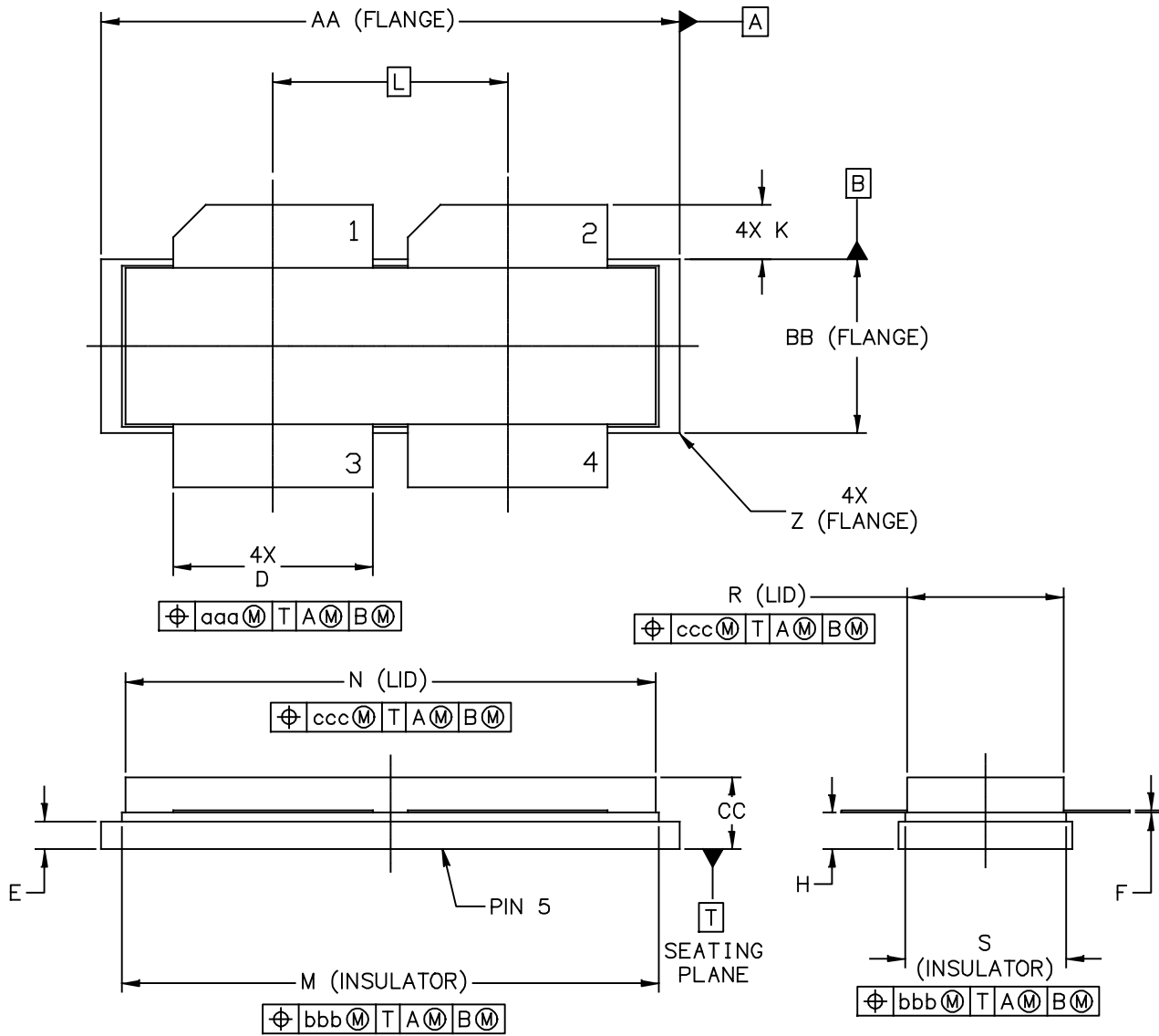


Figure 29. P3dB Load Pull AM/PM Contours (°)

**NOTE:** (P) = Maximum Output Power  
 (E) = Maximum Drain Efficiency

- Gain
- Drain Efficiency
- Linearity
- Output Power

### PACKAGE DIMENSIONS

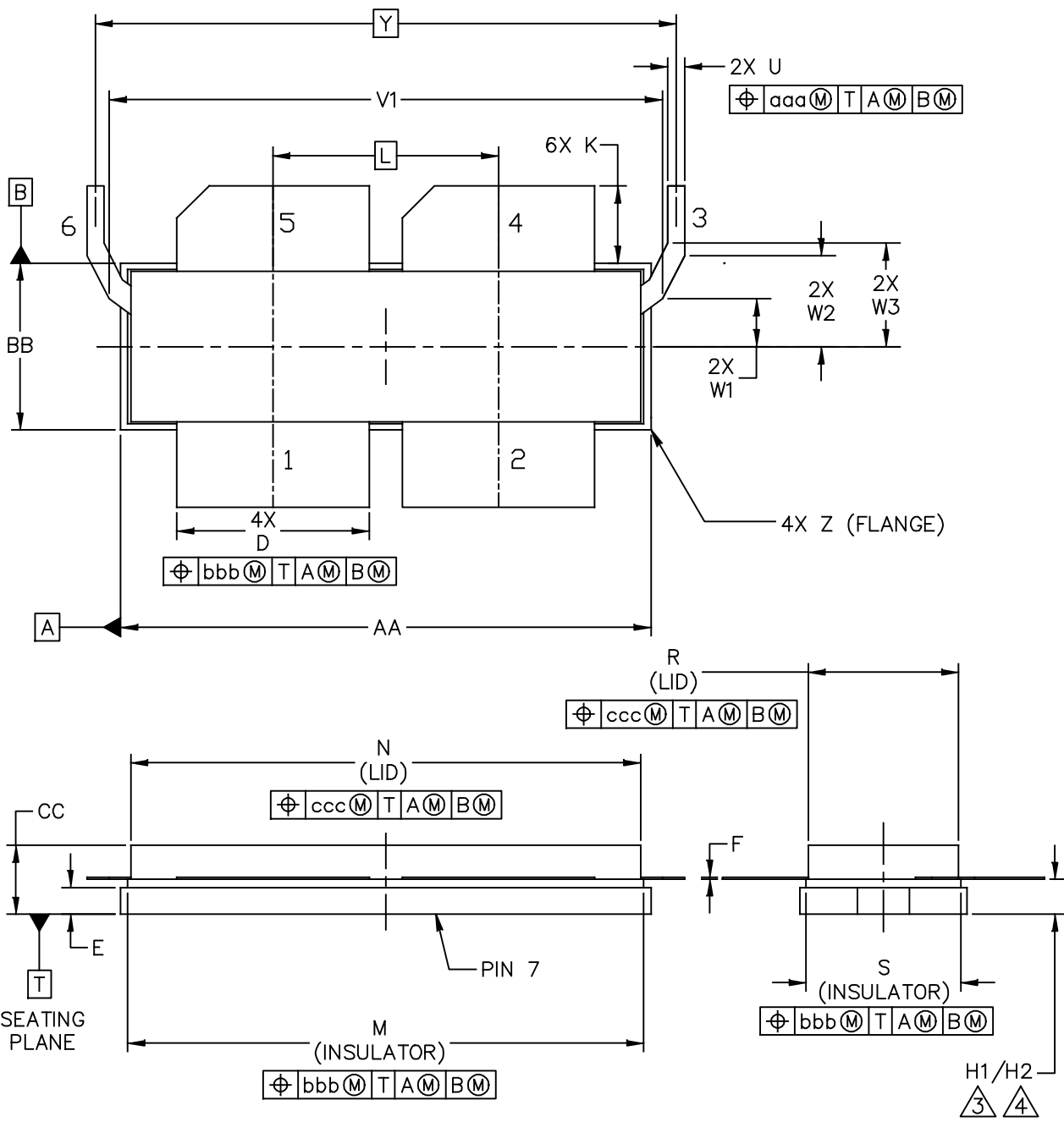


© FREESCALE SEMICONDUCTOR, INC. ALL RIGHTS RESERVED.	MECHANICAL OUTLINE	PRINT VERSION NOT TO SCALE
TITLE:  NI-1230-4S	DOCUMENT NO: 98ARB18247C      REV: G	STANDARD: NON-JEDEC
		01 MAR 2013

NOTES:

1. INTERPRET DIMENSIONS AND TOLERANCES PER ASME Y14.5M–1994.
2. CONTROLLING DIMENSION: INCH
3. DIMENSION H IS MEASURED .030 INCH (0.762 MM) AWAY FROM PACKAGE BODY

DIM	INCHES		MILLIMETERS		DIM	INCHES		MILLIMETERS	
	MIN	MAX	MIN	MAX		MIN	MAX	MIN	MAX
AA	1.265	1.275	32.13	32.39	R	.355	.365	9.02	9.27
BB	.395	.405	10.03	10.29	S	.365	.375	9.27	9.53
CC	.170	.190	4.32	4.83	Z	R.000	R.040	R0.00	R1.02
D	.455	.465	11.56	11.81					
E	.062	.066	1.57	1.68	aaa	.013		0.33	
F	.004	.007	0.10	0.18	bbb	.010		0.25	
H	.082	.090	2.08	2.29	ccc	.020		0.51	
K	.117	.137	2.97	3.48					
L	.540 BSC		13.72 BSC						
M	1.219	1.241	30.96	31.52					
N	1.218	1.242	30.94	31.55					
© FREESCALE SEMICONDUCTOR, INC. ALL RIGHTS RESERVED.			MECHANICAL OUTLINE			PRINT VERSION NOT TO SCALE			
TITLE:  NI-1230-4S					DOCUMENT NO: 98ARB18247C      REV: G				
					STANDARD: NON-JEDEC				
					01 MAR 2013				



© FREESCALE SEMICONDUCTOR, INC. ALL RIGHTS RESERVED.	MECHANICAL OUTLINE	PRINT VERSION NOT TO SCALE
TITLE:  NI-1230-4LS2L	DOCUMENT NO: 98ASA00513D      REV: A	STANDARD: NON-JEDEC
	08 MAR 2013	

NOTES:

1. INTERPRET DIMENSIONS AND TOLERANCES PER ASME Y14.5M-1994.
2. CONTROLLING DIMENSION: INCH

3. DIMENSIONS H1 AND H2 ARE MEASURED .030 INCH (0.762 MM) AWAY FROM FLANGE PARALLEL TO DATUM B. H1 APPLIES TO PINS 1, 2, 4 & 5. H2 APPLIES TO PINS 3 & 6.

4. TOLERANCE OF DIMENSION H2 IS TENTATIVE AND COULD CHANGE ONCE SUFFICIENT MANUFACTURING DATA IS AVAILABLE.

DIM	INCH		MILLIMETER		DIM	INCH		MILLIMETER	
	MIN	MAX	MIN	MAX		MIN	MAX	MIN	MAX
AA	1.265	1.275	32.13	32.39	N	1.218	1.242	30.94	31.55
BB	.395	.405	10.03	10.29	R	.365	.375	9.27	9.53
CC	.170	.190	4.32	4.83	S	.365	.375	9.27	9.53
D	.455	.465	11.56	11.81	U	.035	.045	0.89	1.14
E	.062	.066	1.57	1.68	V1	1.320	1.330	33.53	33.78
F	.004	.007	0.10	0.18	W1	.110	.120	2.79	3.05
H1	.082	.090	2.08	2.29	W2	.213	.223	5.41	5.66
H2	.078	.094	1.98	2.39	W3	.243	.253	6.17	6.43
K	.175	.195	4.45	4.95	Y	1.390 BSC		35.31 BSC	
L	.540 BSC		13.72 BSC		Z	R.000	R.040	R0.00	R1.02
M	1.219	1.241	30.96	31.52	aaa	.015		0.38	
					bbb	.010		0.25	
					ccc	.020		0.51	

© FREESCALE SEMICONDUCTOR, INC. ALL RIGHTS RESERVED.		MECHANICAL OUTLINE	PRINT VERSION NOT TO SCALE
TITLE:  NI-1230-4LS2L		DOCUMENT NO: 98ASA00513D      REV: A	
		STANDARD: NON-JEDEC	
		08 MAR 2013	



## PRODUCT DOCUMENTATION, SOFTWARE AND TOOLS

Refer to the following documents, software and tools to aid your design process.

### Application Notes

- AN1955: Thermal Measurement Methodology of RF Power Amplifiers

### Engineering Bulletins

- EB212: Using Data Sheet Impedances for RF LDMOS Devices

### Software

- Electromigration MTTF Calculator
- RF High Power Model
- .s2p File

### Development Tools

- Printed Circuit Boards

For Software and Tools, do a Part Number search at <http://www.freescale.com>, and select the “Part Number” link. Go to the Software & Tools tab on the part’s Product Summary page to download the respective tool.

## REVISION HISTORY

The following table summarizes revisions to this document.

Revision	Date	Description
0	Nov. 2013	• Initial Release of Data Sheet

### ***How to Reach Us:***

**Home Page:**  
[freescale.com](http://freescale.com)

**Web Support:**  
[freescale.com/support](http://freescale.com/support)

Information in this document is provided solely to enable system and software implementers to use Freescale products. There are no express or implied copyright licenses granted hereunder to design or fabricate any integrated circuits based on the information in this document.

Freescale reserves the right to make changes without further notice to any products herein. Freescale makes no warranty, representation, or guarantee regarding the suitability of its products for any particular purpose, nor does Freescale assume any liability arising out of the application or use of any product or circuit, and specifically disclaims any and all liability, including without limitation consequential or incidental damages. "Typical" parameters that may be provided in Freescale data sheets and/or specifications can and do vary in different applications, and actual performance may vary over time. All operating parameters, including "typicals," must be validated for each customer application by customer's technical experts. Freescale does not convey any license under its patent rights nor the rights of others. Freescale sells products pursuant to standard terms and conditions of sale, which can be found at the following address: [freescale.com/SalesTermsandConditions](http://freescale.com/SalesTermsandConditions).

Freescale and the Freescale logo are trademarks of Freescale Semiconductor, Inc., Reg. U.S. Pat. & Tm. Off. Airfast is a trademark of Freescale Semiconductor, Inc. All other product or service names are the property of their respective owners.

© 2013 Freescale Semiconductor, Inc.



## Стандарт Электрон Связь

Мы молодая и активно развивающаяся компания в области поставок электронных компонентов. Мы поставляем электронные компоненты отечественного и импортного производства напрямую от производителей и с крупнейших складов мира.

Благодаря сотрудничеству с мировыми поставщиками мы осуществляем комплексные и плановые поставки широчайшего спектра электронных компонентов.

Собственная эффективная логистика и склад в обеспечивает надежную поставку продукции в точно указанные сроки по всей России.

Мы осуществляем техническую поддержку нашим клиентам и предпродажную проверку качества продукции. На все поставляемые продукты мы предоставляем гарантию .

Осуществляем поставки продукции под контролем ВП МО РФ на предприятия военно-промышленного комплекса России , а также работаем в рамках 275 ФЗ с открытием отдельных счетов в уполномоченном банке. Система менеджмента качества компании соответствует требованиям ГОСТ ISO 9001.

Минимальные сроки поставки, гибкие цены, неограниченный ассортимент и индивидуальный подход к клиентам являются основой для выстраивания долгосрочного и эффективного сотрудничества с предприятиями радиоэлектронной промышленности, предприятиями ВПК и научно-исследовательскими институтами России.

С нами вы становитесь еще успешнее!

### Наши контакты:

**Телефон:** +7 812 627 14 35

**Электронная почта:** [sales@st-electron.ru](mailto:sales@st-electron.ru)

**Адрес:** 198099, Санкт-Петербург,  
Промышленная ул, дом № 19, литера Н,  
помещение 100-Н Офис 331