



# MAX7322 Evaluation Kit/Evaluation System

## General Description

The MAX7322 evaluation kit (EV kit) is a fully assembled and tested printed circuit board (PCB) that demonstrates the capabilities of the MAX7322 I<sup>2</sup>C port expander with four push-pull outputs and four inputs. The MAX7322 EV kit also includes Windows® 98SE/2000/XP-compatible software, which provides a simple graphical user interface (GUI) for exercising the MAX7322's features.

The MAX7322 evaluation system (EV system) includes a MAX7322 EV kit and a Maxim CMAXQUSB serial-interface board.

The CMAXQUSB board connects to a PC's USB port and allows the transfer of I<sup>2</sup>C commands to the MAX7322 EV kit.

The EV kit comes with the MAX7322ATE+ installed. The MAX7322 EV kit can also be used to evaluate the MAX7319/MAX7320/MAX7321/MAX7323. Contact the factory for free samples of the pin-compatible MAX7319ATE+, MAX7320ATE+, MAX7321ATE+, or MAX7323ATE+ to evaluate these parts.

*Windows is a registered trademark of Microsoft Corp.*

## Features

- ◆ 400kHz I<sup>2</sup>C/2-Wire Serial Interface
- ◆ 1.71V to 5.5V Operation Voltage
- ◆ 4 Push-Pull Output Ports Rated at 20mA Sink Current
- ◆ 4 Input Ports with Maskable, Latching Transition Detection
- ◆ Proven PCB Layout
- ◆ Windows 98SE/2000/XP-Compatible Evaluation Software
- ◆ Fully Assembled and Tested
- ◆ EV System: USB-to-PC Connection

## Ordering Information

PART	TYPE	INTERFACE
MAX7322EVKIT+	EV kit	User-supplied I <sup>2</sup> C interface
MAX7322EVCMAXQU+	EV system	CMAXQUSB board

+Denotes a lead-free and RoHS-compliant EV kit.

**Note:** The MAX7322 EV kit software is designed for use with the complete EV system. The EV system includes both the Maxim CMAXQUSB board and the EV kit. If the Windows software will not be used, the EV kit board can be purchased without the Maxim CMAXQUSB board.

## Component Lists

### MAX7322 EV System

PART	QTY	DESCRIPTION
MAX7322EVKIT+	1	MAX7322 EV kit
CMAXQUSB+	1	Serial-interface board

### MAX7322 EV Kit

DESIGNATION	QTY	DESCRIPTION
C1	1	10µF ±10%, 10V X5R ceramic capacitor (0805) TDK C2012X5R1A106K
C2	1	0.1µF ±15%, 25V X7R ceramic capacitor (0603) TDK C1608X7R1E104K
D1, D3	2	Red LEDs (PLCC4) OPTEK OVSASBC2R8
D2, D4	2	Green LEDs (PLCC4) OPTEK OVSAGBC2R8

DESIGNATION	QTY	DESCRIPTION
D5, D6	0	Not installed, LEDs (PLCC2)
J1	1	2 x 10 right-angle female receptacle
JU1, JU2	2	5-pin headers
JU3	1	2-pin header
JU4	1	3-pin header
R1, R3	2	150Ω ±5% resistors (0603)
R2, R4	2	82Ω ±5% resistors (0603)
R5, R6, R9	3	10kΩ ±5% resistors (0603)
R7, R8, R10, R11	0	Not installed, resistors (0603)
R12	1	2kΩ ±5% resistor (0603)
S1, S2	2	Pushbutton switches
S3, S4	0	Not installed, pushbutton switches
U1	1	MAX7322ATE+ (16-pin TQFN, 3mm x 3mm)
—	1	PCB: MAX7322 Evaluation Kit+



# MAX7322 Evaluation Kit/Evaluation System

## Component Suppliers

SUPPLIER	PHONE	WEBSITE
OPTEK Technologies	800-341-4747	www.optekinc.com
TDK Corp.	847-803-6100	www.component.tdk.com

**Note:** Indicate that you are using the MAX7322 when contacting these component suppliers.

## Quick Start

### Recommended Equipment

- MAX7322 EV system  
MAX7322 EV kit  
CMAXQUSB board  
USB type A-B cable (included with CMAXQUSB)
- A user-supplied computer running Windows 98SE/2000/XP with a spare USB port

**Note:** In the following sections, software-related items are identified by bolding. Text in bold refers to items directly from the EV kit software. Text in **bold and underlined** refers to items from the Windows 98SE/2000/XP operating system.

### Procedure

The MAX7322 EV kit is fully assembled and tested. Follow the steps below to verify board operation:

- 1) Visit the Maxim website (www.maxim-ic.com/evkit-software) to download the latest version of the EV kit software, 7322Rxx.ZIP.
- 2) Install the MAX7322 evaluation software on your computer by running the INSTALL.EXE program. The program files are copied and icons are created in the Windows **Start** menu.
- 3) Enable the I<sup>2</sup>C pullup resistors on the CMAXQUSB board by setting the DIP switches on SW1 to the ON position.

- 4) For the MAX7322 EV kit, make sure that the shunts of all jumpers are in the following default positions:
  - JU1: (1-3) Combined with JU2 makes I<sup>2</sup>C address = 0xC0
  - JU2: (1-4) Combined with JU1 makes I<sup>2</sup>C address = 0xC0
  - JU3: (Open) Normal operation
  - JU4: (2-3) CMAXQUSB provides the power supply
- 5) Connect the boards by aligning the MAX7322 EV kit's 20-pin connector with the 20-pin connector of the CMAXQUSB board.
- 6) Connect the USB cable from the PC to the CMAXQUSB board. A **Building Driver Database** window pops up, in addition to a **New Hardware Found** message if this is the first time it is used on this PC. If you do not see a window that is similar to the one described above after 30s, remove the USB cable from the CMAXQUSB and reconnect it. Administrator privileges are required to install the USB device driver on Windows 2000/XP. Refer to the TROUBLESHOOTING\_USB.PDF document included with the software if you have any problems during this step.
- 7) Follow the directions of the **Add New Hardware Wizard** to install the USB device driver. Choose the **Search for the best driver for your device** option. Specify the location of the device driver to be **C:\Program Files\MAX7322** (default installation directory) using the **Browse** button.
- 8) Start the MAX7322 EV kit software by opening its icon in the **Start** menu. The GUI main window appears, as shown in Figure 1.
- 9) Check or uncheck checkboxes **D0** and/or **D1** above the **Write** button. Press the **Write** button and observe the light change of the LEDs on the EV kit board.

## MAX7322 EV Kit Files

INSTALL.EXE	Installs the EV kit files on your computer
MAX7322.EXE	Application program
FTD2XX.INF	USB device driver file
UNINST.INI	Uninstalls the EV kit software
TROUBLESHOOTING_USB.PDF	USB driver installation help file

# MAX7322 Evaluation Kit/Evaluation System

Evaluate: MAX7322

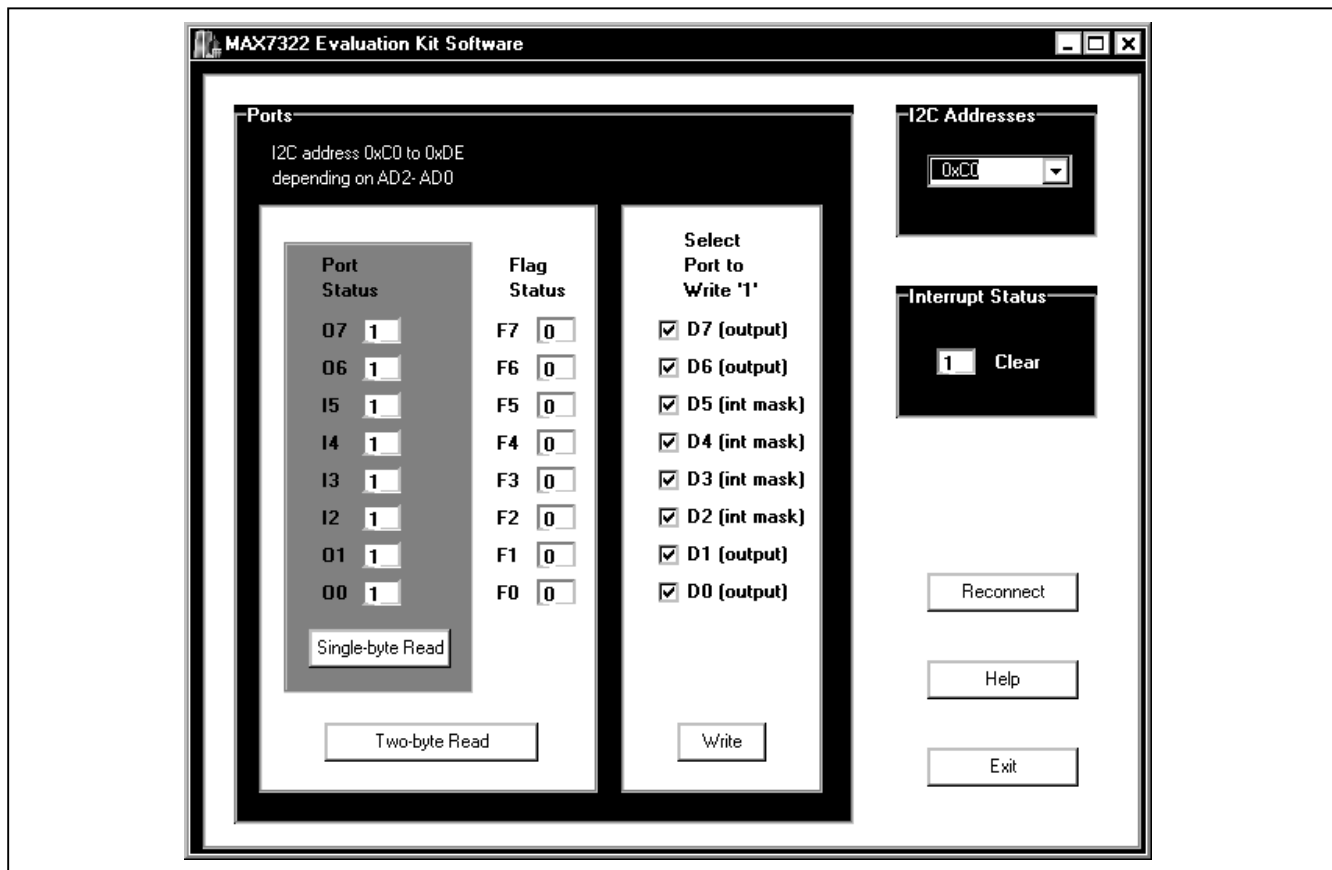

Figure 1. MAX7322 Evaluation Software Main Window

## Detailed Description of Software

To start the MAX7322 EV kit software, double click on the MAX7322 EV kit icon created during installation. The GUI main window appears, as shown in Figure 1.

There are three group boxes on the MAX7322 EV kit GUI software: **Ports**, **I<sup>2</sup>C Addresses**, and **Interrupt Status**. There are also three buttons on the EV kit GUI software: **Reconnect**, **Help**, and **Exit**.

### Ports Group Box

The **Ports** group box shown in Figure 1 contains the read panel and write panel. The read panel consists of two sections: **Port Status** and **Flag Status**.

Pressing the **Single-byte Read** button only reads the port status. Pressing the **Two-byte Read** button reads both port status and flag status.

Check or uncheck the desired checkboxes in the write panel and press the **Write** button to write those settings to the hardware.

### I<sup>2</sup>C Group Box

The **I<sup>2</sup>C Addresses** pulldown menu autodetects the MAX7322's I<sup>2</sup>C slave address when the GUI software starts. If multiple devices are connected to the I<sup>2</sup>C bus, the user can use this pulldown menu to manually change the device's I<sup>2</sup>C slave address according to the shunt position of JU1 and JU2, as shown in Table 1.

### Interrupt Status Group Box

The **Interrupt Status** group box shows the current status of the MAX7322 INT pin, which reflects the latched transition detection of four input ports. Make sure the interrupt mask bits of the input ports are set properly.

### Reconnect, Help, and Exit Buttons

Press the **Reconnect** button to reestablish the connection between the EV kit GUI software and MAX7322 EV kit hardware.

Press the **Help** button to show the MAX7322 EV kit software revision and Maxim's website information.

Press the **Exit** button to quit the MAX7322 EV kit GUI software.

# MAX7322 Evaluation Kit/Evaluation System

## Detailed Description of Hardware

The MAX7322 is an I<sup>2</sup>C port expander with four push-pull outputs and four inputs. The MAX7322 EV kit board provides a proven layout for evaluating the MAX7322. The EV kit comes with a MAX7322ATE+ installed.

### Hardware-Reset Control

The hardware-reset function is controlled by jumper JU3, as shown in Table 2. Putting the shunt in the 1-2 position resets and disables the I<sup>2</sup>C interface.

### I<sup>2</sup>C Address Configuration

The shunt-position combinations of jumpers JU1 and JU2 determine the I<sup>2</sup>C slave address of the MAX7322 EV kit. See Table 1 to select the appropriate setting.

### Power Supplies

The MAX7322 EV kit can be powered from either the CMAXQUSB (2.5V, 3.3V, and 5V) or from a user-supplied 1.71V to 5.5V power supply connecting to VDD, as shown in Table 3.

If the user supplies the power supply, make sure the supplied voltage is compatible with the CMAXQUSB JU1 setting.

### User-Supplied I<sup>2</sup>C Interface

To use the MAX7322 EV kit with a user-supplied I<sup>2</sup>C interface, install the shunt on jumper JU4's 1-2 position. Connect SDA, SCL, and GND lines from the user-supplied I<sup>2</sup>C interface to the SDA, SCL, and GND pads on the MAX7322 EV kit. Apply a 1.71V to 5.5V power supply to the VDD pad of the MAX7322 EV kit. Depending on the configuration of the user-supplied I<sup>2</sup>C interface, it may be necessary to install I<sup>2</sup>C pullup resistors R10 and R11.

Table 1. The I<sup>2</sup>C Address Configuration

SHUNT POSITION		I <sup>2</sup> C ADDRESS
JU2	JU1	
1-4 (SCL)*	1-3 (GND)*	1100000x (0xC0)
1-4 (SCL)	1-2 (VCC)	1100001x (0xC2)
1-4 (SCL)	1-4 (SCL)	1100010x (0xC4)
1-4 (SCL)	1-5 (SDA)	1100011x (0xC6)
1-5 (SDA)	1-3 (GND)	1100100x (0xC8)
1-5 (SDA)	1-2 (VCC)	1100101x (0xCA)
1-5 (SDA)	1-4 (SCL)	1100110x (0xCC)
1-5 (SDA)	1-5 (SDA)	1100111x (0xCE)
1-3 (GND)	1-3 (GND)	1101000x (0xD0)
1-3 (GND)	1-2 (VCC)	1101001x (0xD2)
1-3 (GND)	1-4 (SCL)	1101010x (0xD4)
1-3 (GND)	1-5 (SDA)	1101011x (0xD6)
1-2 (VCC)	1-3 (GND)	1101100x (0xD8)
1-2 (VCC)	1-2 (VCC)	1101101x (0xDA)
1-2 (VCC)	1-4 (SCL)	1101110x (0xDC)
1-2 (VCC)	1-5 (SDA)	1101111x (0xDE)

\*Default position.

Table 2. Reset Jumper Configuration

JUMPER	SHUNT POSITION	DESCRIPTION
JU3	1-2	Reset
	Open*	Normal operation

\*Default position.

Table 3. V+ Selection Configuration

JUMPER	SHUNT POSITION	DESCRIPTION
JU4	1-2	User-provided 1.71V to 5.5V power supply (VDD)
	2-3*	Powered by CMAXQUSB

\*Default position.

# MAX7322 Evaluation Kit/Evaluation System

Evaluate: MAX7322

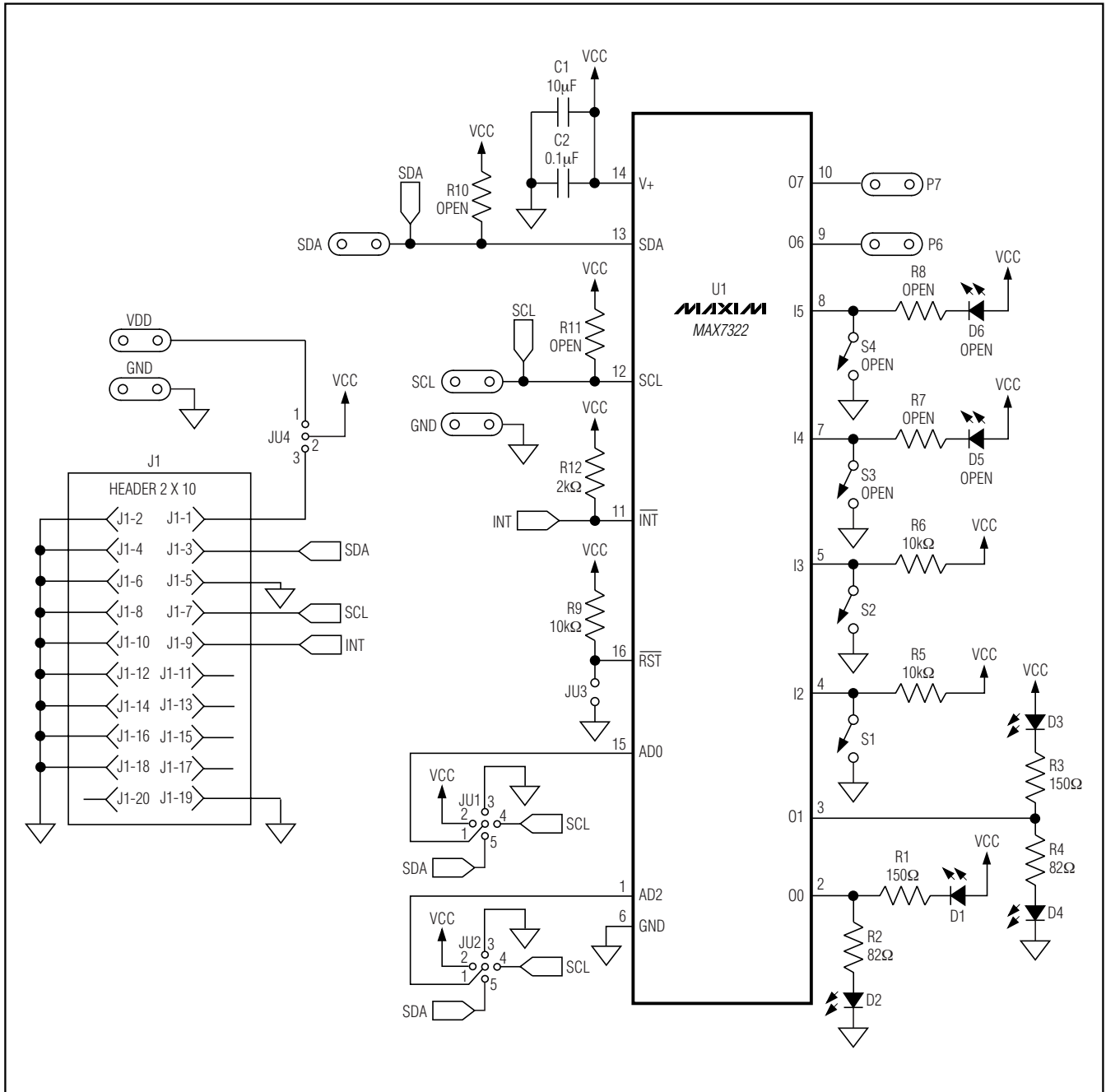

Figure 2. MAX7322 EV Kit Schematic

# MAX7322 Evaluation Kit/Evaluation System

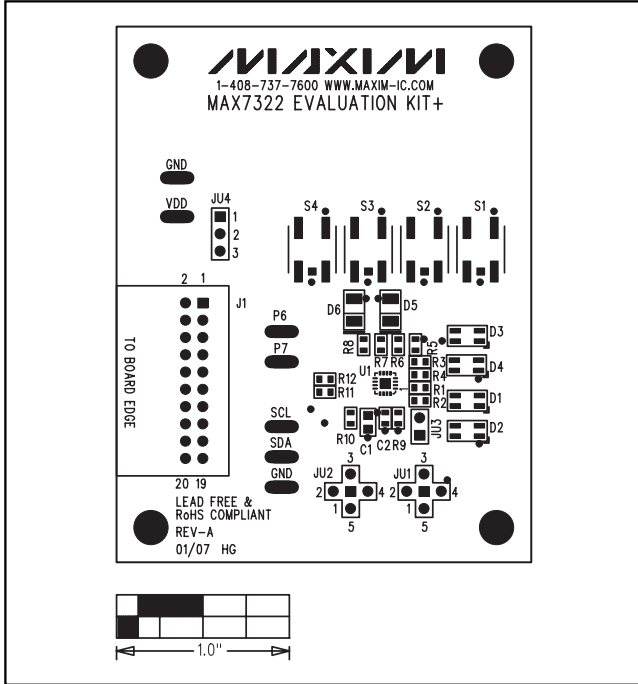

Figure 3. MAX7322 EV Kit Component Placement Guide—Component Side

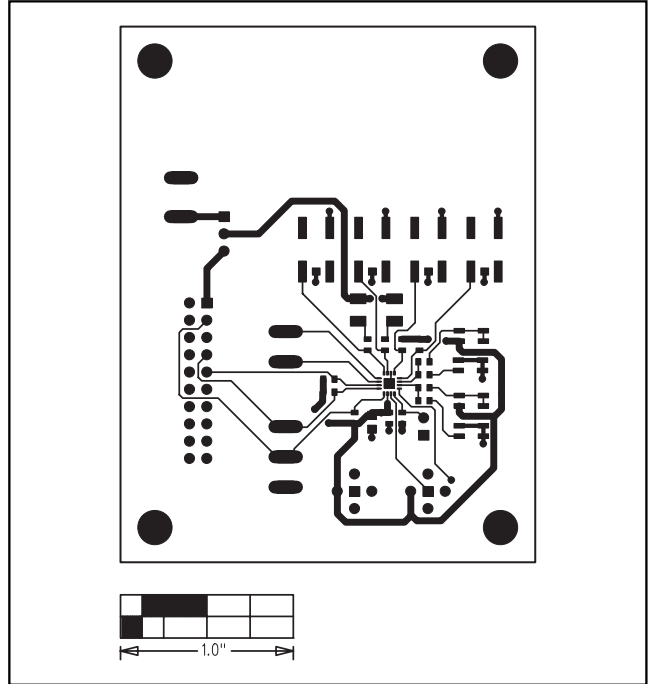

Figure 4. MAX7322 EV Kit PCB Layout—Component Side

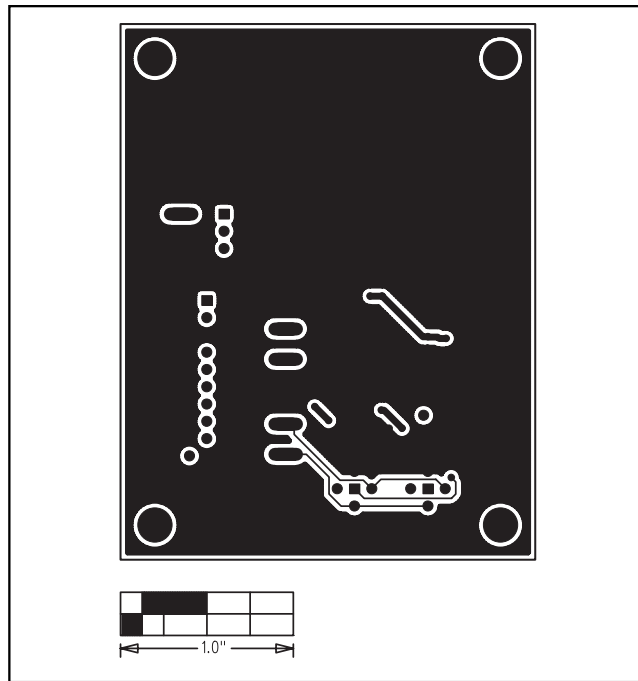

Figure 5. MAX7322 EV Kit PCB Layout—Solder Side

Maxim cannot assume responsibility for use of any circuitry other than circuitry entirely embodied in a Maxim product. No circuit patent licenses are implied. Maxim reserves the right to change the circuitry and specifications without notice at any time.

6 **Maxim Integrated Products, 120 San Gabriel Drive, Sunnyvale, CA 94086 408-737-7600**

© 2007 Maxim Integrated Products

**MAXIM** is a registered trademark of Maxim Integrated Products, Inc.



## Стандарт Электрон Связь

Мы молодая и активно развивающаяся компания в области поставок электронных компонентов. Мы поставляем электронные компоненты отечественного и импортного производства напрямую от производителей и с крупнейших складов мира.

Благодаря сотрудничеству с мировыми поставщиками мы осуществляем комплексные и плановые поставки широчайшего спектра электронных компонентов.

Собственная эффективная логистика и склад в обеспечивает надежную поставку продукции в точно указанные сроки по всей России.

Мы осуществляем техническую поддержку нашим клиентам и предпродажную проверку качества продукции. На все поставляемые продукты мы предоставляем гарантию .

Осуществляем поставки продукции под контролем ВП МО РФ на предприятия военно-промышленного комплекса России , а также работаем в рамках 275 ФЗ с открытием отдельных счетов в уполномоченном банке. Система менеджмента качества компании соответствует требованиям ГОСТ ISO 9001.

Минимальные сроки поставки, гибкие цены, неограниченный ассортимент и индивидуальный подход к клиентам являются основой для выстраивания долгосрочного и эффективного сотрудничества с предприятиями радиоэлектронной промышленности, предприятиями ВПК и научно-исследовательскими институтами России.

С нами вы становитесь еще успешнее!

### Наши контакты:

**Телефон:** +7 812 627 14 35

**Электронная почта:** [sales@st-electron.ru](mailto:sales@st-electron.ru)

**Адрес:** 198099, Санкт-Петербург,  
Промышленная ул, дом № 19, литера Н,  
помещение 100-Н Офис 331