

Image Sensor Demo System Kits

Introduction

The Micron[®] Imaging demonstration system family supports the full line of Micron's CMOS image sensor products. The current demonstration system is called the DEMO2, which uses the USB 2 interface to transport raw digital video data from the sensor to the host PC. Several software applications are provided with the demonstration system to enable the user to display the data from the sensor on the host computer, and to change some basic settings of the sensor for evaluation purposes. A software development kit (SDK) is also provided to customers who wish to write their own software applications to access the sensor on the demo system.

The front board contains the lens and the imaging sensor. The back board contains the USB 2 controller and is called the DEMO2 board (shown in Figure 1).

Figure 1: Demo Board and Sensor Headboard

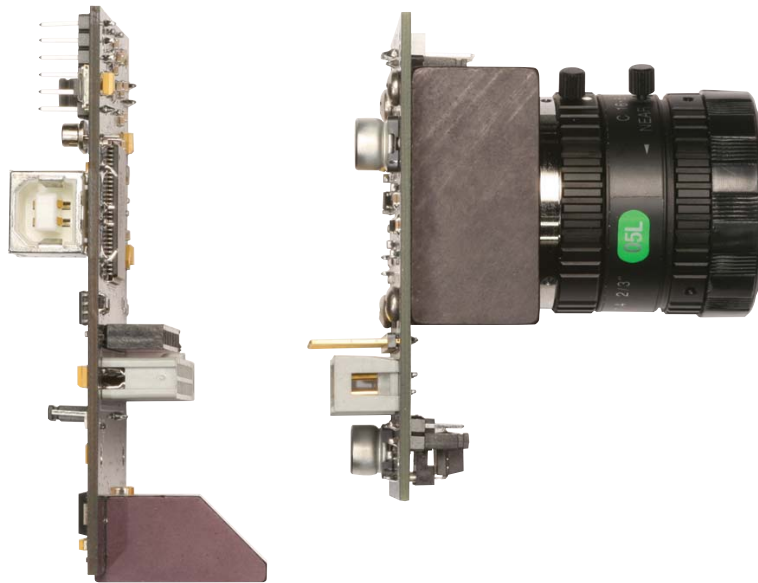

Hardware Requirements

- Pentium III 450 MHz or higher (a faster processor will improve the displayed frame rate on the PC)
- 128MB RAM
- USB 2.0 Host controller (we recommend Adaptec's "USB 2 CONNECT" PCI USB2 adapter and their part number is AUA-3100LP and AUA-1420A for notebook PCs)

Software Requirements

- Windows 2000 with a minimum of Service Pack 2 or Windows XP with a minimum of Service Pack 1
- The latest drivers for the USB 2.0 host controller

Note: We do not recommend Windows 2000 with built-in USB2 controllers.

Demonstration System Contents

- Micron Imaging demo camera board
- Micron sensor head with lens
- USB 2.0 cable
- Software CD
- Demo user manual
- Camera tripod

Figure 2: C-Mount, S-Mount, and Mini Lens with a Lens Evaluation Adapter

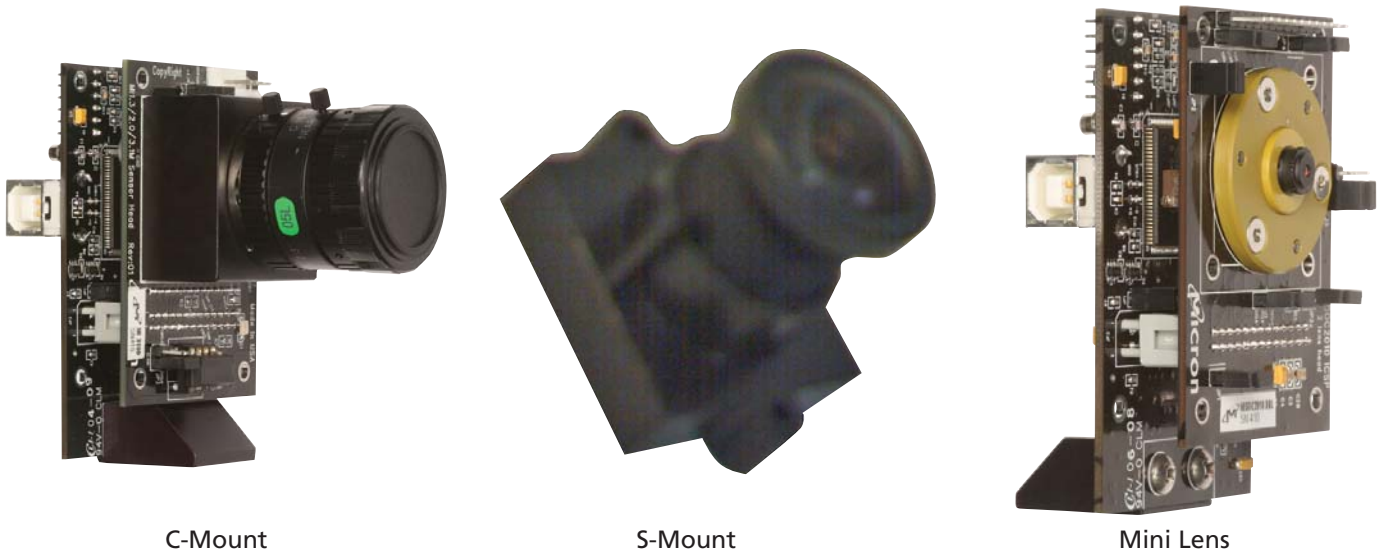

Product Matrix

Below is a list of our products with their available lens type. Note that the DEMO2 board is able to run at the full clock speed for each sensor, although it is also possible to run at slower clock speeds. Refer to the ordering info for part numbers and ordering information.

Table 1: Product Matrix

Sensor	Lens Type			
	SOC	C-Mount	S-Mount	Mini Lens with a Lens Evaluation Adapter
MT9V011		√		
MT9M011		√		
MT9T012		√		
MT9V111				
MT9V131				
MT9V112				√
MT9V125			√	
MT9V135			√	
MT9M111 ¹		√		√
MT9M131		√		√
MT9M112				√
MT9D111				√
MT9D131				√
MT9D112				√
Non-SOC	C-Mount	S-Mount	Mini Lens with a Lens Evaluation Adapter	
MT9V011	√			
MT9V022	√			
MT9V032	√			
MT9M001	√			
MT9M011	√			
MT9D011	√		√	
MT9T001	√			
MT9T031	√			
MT9T012			√	
MT9P001	√		√	
MT9P031	√		√	

Notes: 1. DEMO2 can only support a maximum of 47 MHz oscillators even though the nominal clock for the MT9M111 is 54 MHz.

Operational Description

Board Functionality

The USB board provides centralized communication between the image sensor and the host PC. The system receives firmware programming from a serial EEPROM that configures the board into a synchronous slave FIFO mode. The sensor data fills up an internal FIFO with data when the elimination of handshake is taking place. The firmware automatically sends data through the USB 2.0 interface whenever the FIFO becomes full and the FRAME_VALID is polled to determine when a frame is complete. When the FRAME_VALID drops, the host computer is signaled through the USB interface with a frame end packet. The firmware also supplies the necessary code to implement USB vendor commands that allow the host computer to query and modify the system configuration data.

Vendor commands are used to communicate with the image sensor through the serial host interface protocol built into the sensor head interface.

Figure 3: DEMO2 Board Block Diagram

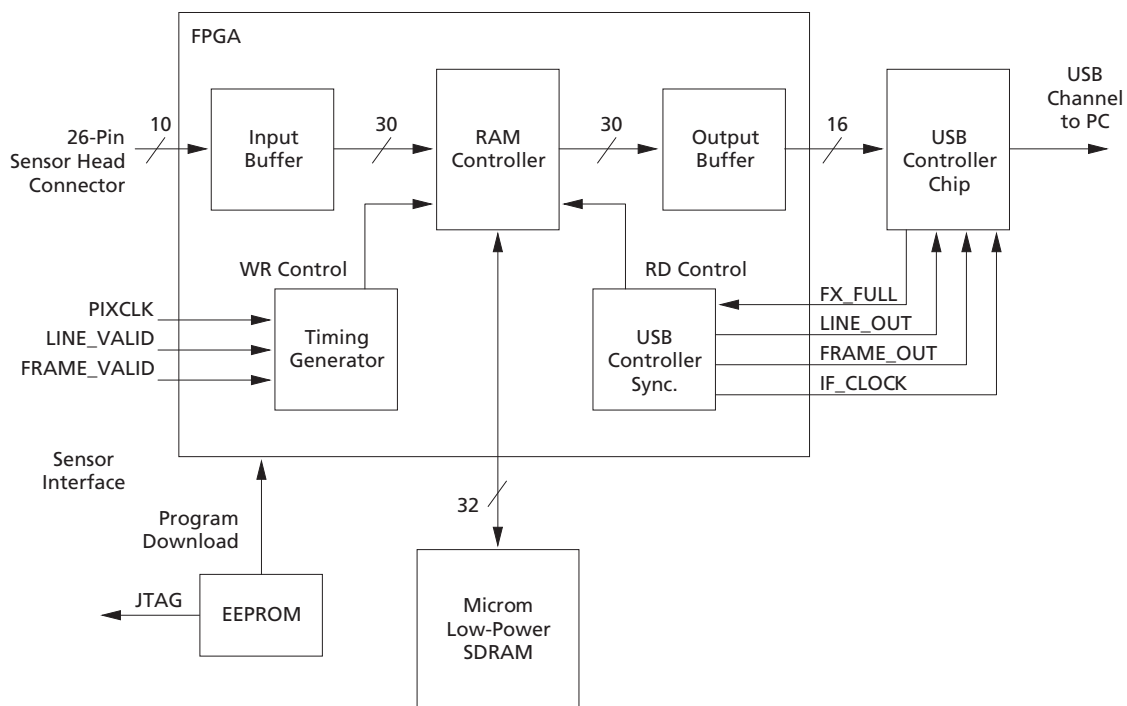

DEMO2

Micron's DEMO2 board comes equipped with the addition of an FPGA and memory controller. This allows the hardware to store up to three entire frames of data on the board prior to USB 2 transport, which is important for large resolution sensors to avoid dropping frames. The DEMO2 baseboards are common to all sensor configurations. The FPGA optimizes the data flow through the USB, such that the FIFOs never overflow and complete frames are guaranteed even for large sensors.

Ordering Information

For ordering information, contact your local sales representative at micron.com/purchasing.

Table 2: Part Number Ordering

SOC	Part Numbers	Kit Description
MT9V111	MT9V111I99STCD ES MT9V111I99STCH ES	MT9V111 color VGA complete demo kit MT9V111 color VGA demo head board
MT9V112	MT9V112I2ASTCD ES MT9V112I2ASTCH ES	MT9V112 color VGA complete demo kit MT9V112 color VGA demo head board
MT9V125	MT9V125IA7XTCD ES MT9V125IA7XTCH ES	MT9V125 color VGA complete demo kit (auto) MT9V125 color VGA demo head board (auto)
MT9M111 ¹	MT9M111P12STCD ES MT9M111P12STCH ES	MT9M111 color 1.3Mp complete demo kit MT9M111 color 1.3Mp demo head board
MT9M112	MT9M112PA3STCD ES MT9M112PA3STCH ES	MT9M112 color 1.3Mp complete demo kit MT9M112 color 1.3Mp demo head board
MT9M113	MT9M113PACSTCD ES MT9M113PACSTCH ES	MT9M113 color 1.3Mp complete demo kit MT9M113 color 1.3Mp demo head board
MT9D111	MT9D111I93STCD ES MT9D111I93STCH ES	MT9D111 color 2Mp complete demo kit MT9D111 color 2Mp demo head board
MT9D112	MT9D112I93STCD ES MT9D112I93STCH ES	MT9D112 color 2Mp complete demo kit MT9D112 color 2Mp demo head board
MT9D131	MT9D131C12STCD ES MT9D131C12STCH ES	MT9D131 color 2Mp complete demo kit MT9D131 color 2Mp demo head board
MT9M131	MT9M131C12STCD ES MT9M131C12STCH ES	MT9M131 color 1.3Mp complete demo kit MT9M131 color 1.3Mp demo head board
MT9V135	MT9V135C12STCD ES MT9V135C12STCH ES	MT9V135 color VGA complete demo kit MT9V135 color VGA demo head board
MT9V131	MT9V131C12STCD ES MT9V131C12STCH ES	MT9V131 color VGA complete demo kit MT9V131 color VGA demo head board
MT9V113	MT9V113PACSTCD ES MT9V113PACSTCH ES	MT9V113 color VGA complete demo kit MT9V113 color VGA demo head board
Non-SOC	Part Numbers	Kit Description
MT9V011	MT9V011P11STCD ES:B MT9V011P11STCH ES:B	MT9V011 color VGA complete demo kit MT9V011 color VGA demo head board
MT9V013	MT9V013PACSTCDM ES MT9V013PACSTCHM ES MT9V013PACSTCDP ES MT9V013PACSTCHP ES	MT9V013 color VGA complete demo kit (MIPI added) MT9V013 color VGA demo head board (MIPI added) MT9V013 color VGA complete demo kit (CCP added) MT9V013 color VGA demo head board - (CCP added)
MT9V022	MT9V022I77ATMD ES MT9V022I77ATMH ES MT9V022I77ATCD ES MT9V022I77ATCH ES	MT9V022 monochrome VGA complete demo kit (auto) MT9V022 monochrome VGA demo head board (auto) MT9V022 color VGA complete demo kit (auto) MT9V022 color VGA demo head board (auto)
MT9M001	MT9M001C12STMD ES MT9M001C12STMH ES	MT9M001 monochrome SXGA complete demo kit MT9M001 monochrome SXGA demo head board
MT9M019	MT9M019IA9STCD ES MT9M019IA9STCH ES	MT9M019 color 1.3Mp complete demo kit MT9M019 color 1.3Mp demo head board
MT9D011	MT9D011I29STCD ES MT9D011I29STCH ES	MT9D011 color 2Mp complete demo kit MT9D011 color 2Mp demo head board
MT9D012	MT9D012IA3STCD ES MT9D012IA3STCH ES	MT9D012 color 2Mp complete demo kit MT9D012 color 2Mp demo head board

Table 2: Part Number Ordering (continued)

MT9T001	MT9T001P12STCD ES MT9T001P12STCH ES	MT9T001 color 3Mp complete demo kit MT9T001 color 3Mp demo head board
MT9T012	MT9T012IA3STCD ES:C MT9T012IA3STCH ES:C	MT9T012 color 3.1Mp complete demo kit MT9T012 color 3.1Mp demo head board
MT9P011	MT9P011112STCD ES MT9P011112STCH ES	MT9P011 color 5Mp complete demo kit - 22° shift MT9P011 color 5Mp demo head board - 22° shift
MT9P001	MT9P001112STCD ES:B MT9P001112STCH ES:B	MT9P001 color 5Mp complete demo kit - 7° shift MT9P001 color 5Mp demo head board - 7° shift
MT9P031	MT9P031112STCD ES MT9P031112STCH ES	MT9P031 color 5Mp complete demo kit - 7° shift MT9P031 color 5Mp demo head board - 7° shift
MT9T013	MT9T013PACSTCDM ES MT9T013PACSTCHM ES MT9T013PACSTCDP ES MT9T013PACSTCHP ES	MT9T013 color 3Mp complete demo kit (MIPI) MT9T013 color 3Mp demo head board (MIPI) MT9T013 color 3Mp complete demo kit (CCP) MT9T013 color 3Mp demo head board (CCP)
MT9T031	MT9T031P12STCD ES MT9T031P12STCH ES	MT9T031 color 3Mp complete demo kit MT9T031 color 3Mp demo head board
MT9P401	MT9P401112STCD ES MT9P401112STCH ES	MT9P401 color 5Mp HD complete demo kit MT9P401 color 5Mp HD demo head board
MT9P012	MT9P012PACSTCDM ES MT9P012PACSTCHM ES MT9P012PACSTCDP ES MT9P012PACSTCHP ES	MT9P012 color 5Mp complete demo kit (MIPI) MT9P012 color 5Mp demo head board (MIPI) MT9P012 color 5Mp complete demo kit (CCP) MT9P012 color 5Mp demo head board (CCP)
MT9V032	MT9V032C12STCD ES MT9V032C12STCH ES MT9V032C12STMD ES MT9V032C12STMH ES	MT9V032 color VGA complete demo kit MT9V032 color VGA demo head board MT9V032 monochrome VGA complete demo kit MT9V032 monochrome VGA demo head board

Notes: 1. DEMO2 can only support a maximum of 47 MHz oscillators even though the nominal clock for the MT9M111 is 54 MHz.



8000 S. Federal Way, P.O. Box 6, Boise, ID 83707-0006, Tel: 208-368-3900
 prodmtg@micron.com www.micron.com Customer Comment Line: 800-932-4992

Micron, the M logo, the Micron logo, and DigitalClarity are trademarks of Micron Technology, Inc. All other trademarks are the property of their respective owners. Micron Technology, Inc. All rights reserved. All information is provided "AS IS," without warranties of any kind, and is subject to change without notice.



Стандарт Электрон Связь

Мы молодая и активно развивающаяся компания в области поставок электронных компонентов. Мы поставляем электронные компоненты отечественного и импортного производства напрямую от производителей и с крупнейших складов мира.

Благодаря сотрудничеству с мировыми поставщиками мы осуществляем комплексные и плановые поставки широчайшего спектра электронных компонентов.

Собственная эффективная логистика и склад в обеспечивает надежную поставку продукции в точно указанные сроки по всей России.

Мы осуществляем техническую поддержку нашим клиентам и предпродажную проверку качества продукции. На все поставляемые продукты мы предоставляем гарантию .

Осуществляем поставки продукции под контролем ВП МО РФ на предприятия военно-промышленного комплекса России , а также работаем в рамках 275 ФЗ с открытием отдельных счетов в уполномоченном банке. Система менеджмента качества компании соответствует требованиям ГОСТ ISO 9001.

Минимальные сроки поставки, гибкие цены, неограниченный ассортимент и индивидуальный подход к клиентам являются основой для выстраивания долгосрочного и эффективного сотрудничества с предприятиями радиоэлектронной промышленности, предприятиями ВПК и научно-исследовательскими институтами России.

С нами вы становитесь еще успешнее!

Наши контакты:

Телефон: +7 812 627 14 35

Электронная почта: sales@st-electron.ru

Адрес: 198099, Санкт-Петербург,
Промышленная ул, дом № 19, литера Н,
помещение 100-Н Офис 331