

1 The AS5045 Adapter PCB

The AS5045 adapter PCB is a simple circuit allowing customers to test and evaluate the AS5045 rotary encoder rapidly without having to build their own test fixture or PCB.

The PCB can be used as standalone unit or plugged onto the AS5045 demo board as external encoder. For Standalone operation, it can be supplied with 3.3V, 5V or 7.5...12V DC supply voltages.

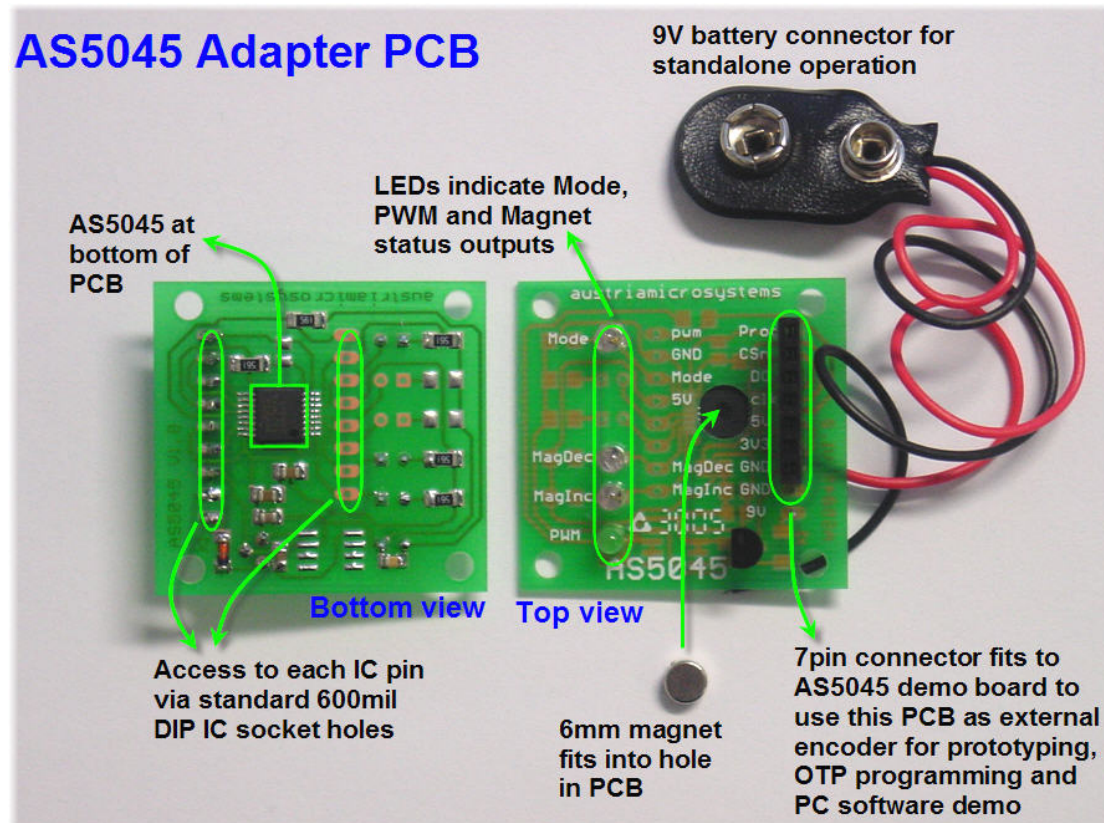

Figure 1: AS5045 Adapter PCB: top and bottom view

Features:

- 100mil connector for direct connection to AS5045 demo board
- Provision for a 600mil DIP socket
- Hole in PCB to center a 6mm magnet at the bottom of the IC
- LED for Mode output
- LED for PWM output
- LEDs for magnet status outputs MagInc, MagDec
- On-board 5V linear voltage regulator for 7.5...12V supplies
- 9V battery connector for standalone operation
- Dimensions: 35mm x 37mm (1.38 x 1.46 inch)

2 General Description

The AS5045 is a system-on-chip, combining integrated Hall elements, analog front end and digital signal processing in a single device. It provides incremental output signals and the absolute angular position of a magnet that is placed either above or below the device.

The AS5045 can be configured to specific customer requirements by programming the integrated OTP (one time programmable) register. An internal voltage regulator allows the AS5045 to operate at either 3.3 V or 5 V supplies.

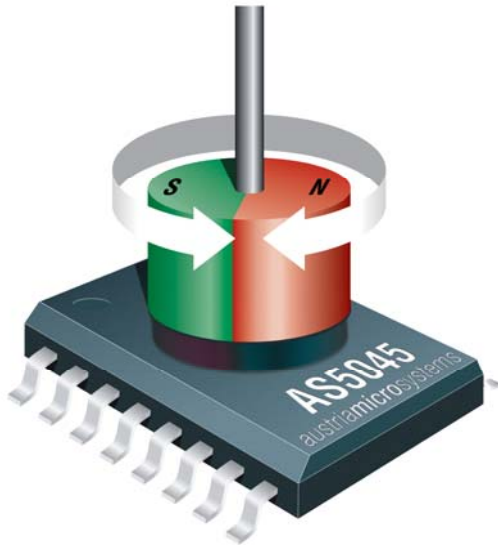

Figure 2: Typical arrangement AS5045 and magnet

3 Pin Configuration

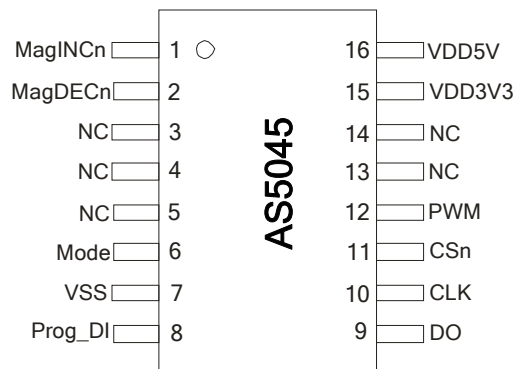

Figure 3: Pin configuration SSOP16

4 Pin Description

Pin	Symbol	Type	Description
1	MagINCn	DO_OD	Magnet Field Magnitude INC rease; active low, indicates a distance reduction between the magnet and the device surface. See Error! Reference source not found.
2	MagDECn	DO_OD	Magnet Field Magnitude DEC rease; active low, indicates a distance increase between the device and the magnet. See Error! Reference source not found.
3	NC	-	must be left unconnected
4	NC	-	must be left unconnected
5	NC	-	must be left unconnected
6	Mode	-	select between slow (open, low :VSS) and fast (high) mode. Internal pull-down resistor.
7	VSS	S	Negative Supply Voltage (GND)
8	Prog_DI	DI_PD	OTP Programming Input and Data Input for Daisy Chain mode. Internal pull-down resistor (~74kΩ). Connect to VSS if not used
9	DO	DO_T	Data Output of Synchronous Serial Interface
10	CLK	DI, ST	Clock Input of Synchronous Serial Interface; Schmitt-Trigger input
11	CSn	DI_PU, ST	Chip Select, active low; Schmitt-Trigger input, internal pull-up resistor (~50kΩ)
12	PWM	DO	Pulse Width Modulation of approx. 1kHz; LSB in <i>Made3.x</i>
13	NC	-	Must be left unconnected
14	NC	-	Must be left unconnected
15	VDD3V3	S	3V-Regulator Output, internally regulated from VDD5V. Connect to VDD5V for 3V supply voltage. Do not load externally.
16	VDD5V	S	Positive Supply Voltage, 3.0 to 5.5 V

Table 1: Pin description

5 Principle of Operation

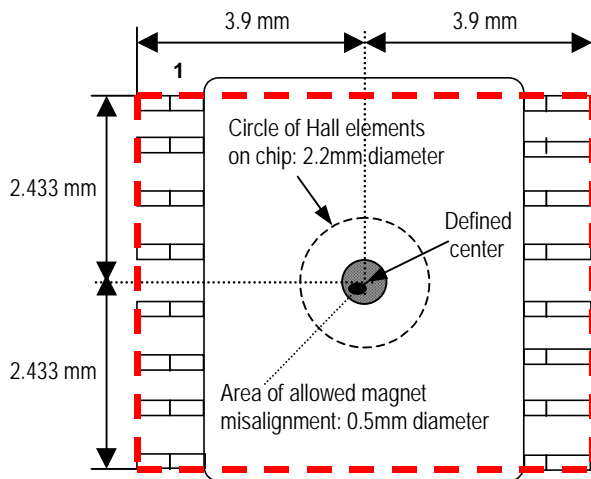

Figure 4: Tolerances of magnet placement

The AS5045 chip consists of a ring of hall elements, placed at the center of the IC at a circle diameter of 2.2mm (86.6mil).

The hall elements pick up the field of a magnet, placed atop this hall array circle. This information is digitized and fed into a digital signal processor (DSP), which calculates the angle of the magnet with a resolution of 0.0879 degrees or 4096 positions per revolution (12bit) at a sampling rate of 96 μ s (10kHz; Default) or 384 μ s (2.6kHz).

The digital angle information is available in several formats: as serial 12-bit data stream, as pulse-width modulated (PWM) signal or as quadrature incremental signal

5.1 Magnet considerations

A magnet, having one north / one south pole in the horizontal axis is placed right above the ring of hall elements (see Figure 2). The magnet does not necessarily need to be circular, it can be rectangular as well, as long as the north and south pole are arranged horizontally over the center of the hall array ring.

The magnetic field strength along this ring should be in the range of $\pm 45 \dots 75$ milliTesla (mT).

5.1.1 Magnet size

The size of the magnet should be at least the size of the hall array ring (2.2mm). Smaller magnets are more critical in terms of misalignment due to the non-linear magnetic field distribution along the circumference of the magnet. The recommended magnet diameter is 4...6mm

5.1.2 Magnet distance and material

To achieve the required field strength at a reasonable distance (~0.5...5mm), it is recommended to use rare-earth magnets, such as Samarium-Cobalt (SmCo) or Neodyme-Iron-Boron (NdFeB) magnets.

5.1.3 Magnet misalignment

In theory, the magnet misalignment is not critical for this type of angular measurement. In practice however, magnets are not perfectly linear. The magnetic field strength does not increase linearly with the radius. As you get towards the boundary of the magnet, the magnetic field comes to a maximum and then weakens as you move further away from the center. Therefore, a magnet should be chosen, that is still in the linear range at a <3mm diameter.

5.1.4 Non-linearity errors

A non-linear magnetic field results in a non-sinusoidal representation of the magnet, which in turn causes non-linearities in the calculated angle (calculated angle differs from actual angle).

With a perfectly centered magnet, the maximum error is $\leq \pm 0,5$ degrees. This error is caused by internal mismatch and gain errors.

With the recommended 4mm magnet (Bomatec BMN-35H), the maximum error of $\leq \pm 1.4$ degrees (including internal errors and temperature related errors) can be achieved while the magnet is off-center by a radius of <0.25mm (see Figure 4).

6 AS5045 Adapter PCB Schematic:

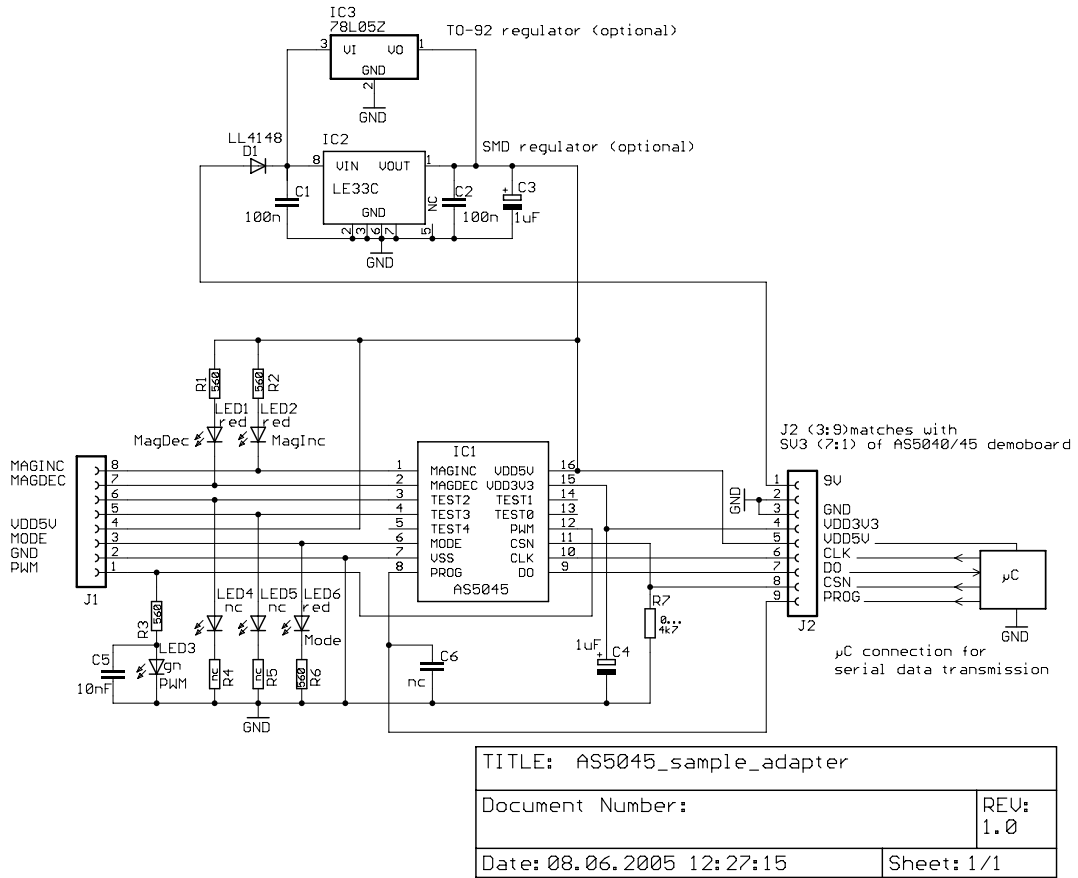

Figure 5: AS5045 Adapter PCB schematic

For normal operation, the only required external components are the buffer cap at VDD3V3 (C4) and the pull-down resistor for CSn (R7; 0Ω...4k7).

The PCB operates at several power supply levels:

Power Supply options:

Supply voltage	apply at	ext. voltage regulator IC2 or IC3	digital I/O level	remark
3.0...3.6V	VDD5V and VDD3V3	not required *)	3.0...3.6V	short VDD5V and VDD3V3
4.5...5.5V	VDD5V	not required *)	4.5...5.5V	short VDD5V and VDD3V3
7.5...20V	ext. voltage regulator (pin 1, J2)	3.3V type, e.g. LE33C (ST Micro)	3.3V	short VDD5V and VDD3V3
7.5...20V	ext. voltage regulator (pin 1, J2)	5.0V type e.g. 75L05	5.0V	PCB delivery status

*) if already installed, external voltage regulator can be left installed.

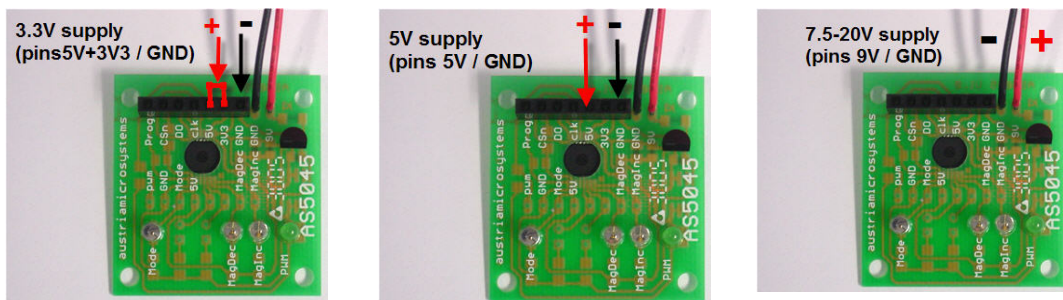

Figure 6: how to connect various power supply levels to the adapter PCB

Output modes:

a) PWM output:

no additional components are necessary. Once the power supply has been applied, the angle information is available at the PWM pin (pin1 of J1)

b) Absolute angle information

To access the 12-bit absolute angle information, an external microcontroller must be connected as shown in Figure 5. Make sure that the controller is able to drive the CSn pin with the connected pulldown resistor (R7). If necessary, remove this resistor.

The clock rate can be as high as 1MHz. There is no minimum clock rate. Data can also be clocked manually. The digital I/O's of the AS5045 are buffered by VDD5V, therefore the digital I/O's of the controller should be at the same voltage level (see power supply options table).

d) Magnetic field strength status; Pushbutton function

no additional components are necessary. The two open-drain outputs MagInc and MagDec (pins 8 and 7 of J1) will turn on/off as the magnetic field (distance between magnet and chip surface) changes. When both outputs are on, the magnetic field is not within the recommended range (see datasheet).

Programming (zapping) the Chip.

For programming the AS5045, 3 digital signals are required: CSn, Prog and CLK (see datasheet). For permanent writing, VPROG must be elevated to 7.5V during the programming cycle.

For immediate programming, this PCB can be connected directly to the AS5045 demo board (available separately), where all the programming timings are generated by the onboard microcontroller.

AS5045 adapter PCB layout and component placement:

The PCB has several connection options. All required pins are accessible via the two 100mil- connectors J1 and J2.

These connectors are 600mil apart, which allows them to be soldered to a wide 16-pin DIL IC socket for easier access or ribbon cable connection.

Furthermore, J2 (pins 3..9) fit to the AS5045 demo board and allow this PCB to be used as external encoder.

The hole in the PCB underneath the chip allows centering of a 6mm diameter magnet.

The 6 LEDs and voltage regulators are optional. Minimum required components are C4 (1µF) and R7 (0...4k7).

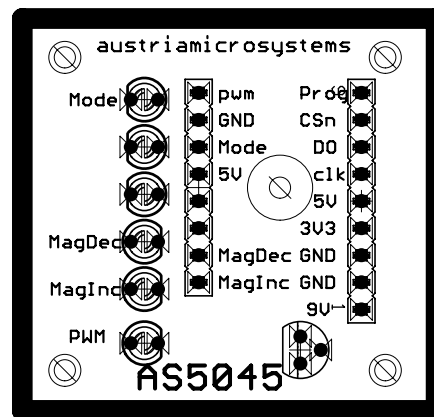

AS5045 adapter board: top view

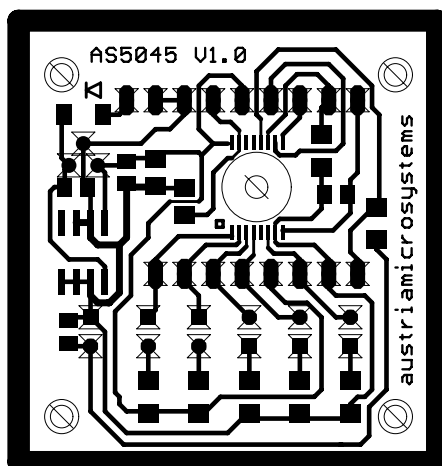

Layout: Bottom View

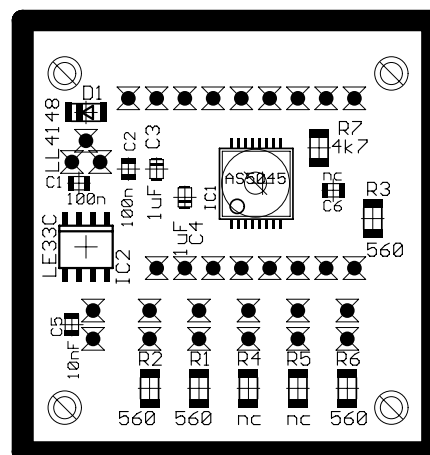

Layout: Bottom Components

AS5045 adapter PCB dimensions:

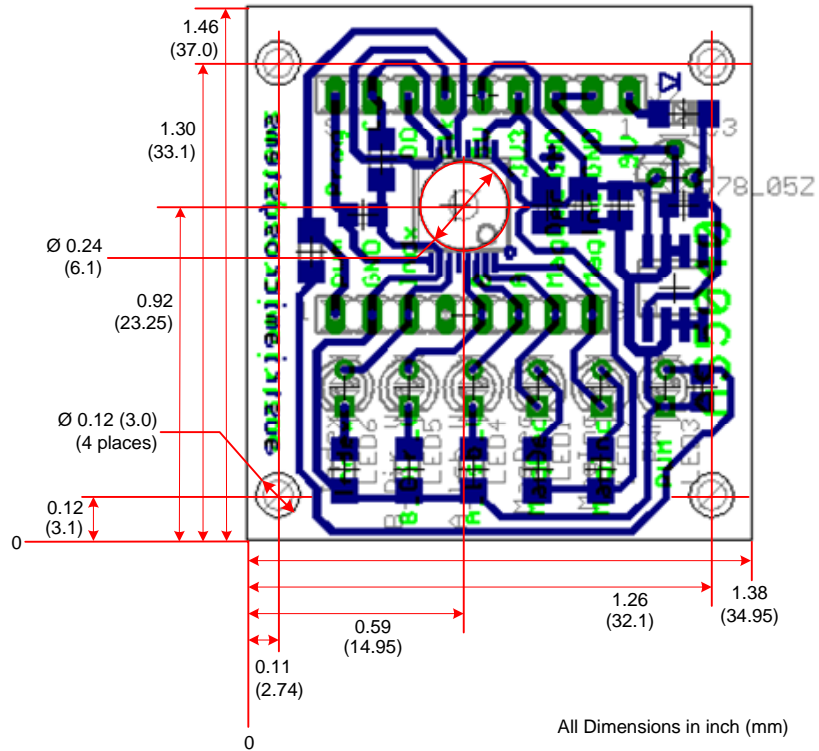

Figure 7: AS5045 adapter board dimensions.

7 Supporting Tools

austriamicrosystems provides the following tools for developments using the AS5045 rotary encoder IC:
AS5045 Demoboard (see Figure 8)
AS5045 Demoboard Operation Manual
AS5045 Demoboard Software
AS5045 Adapter PCB (see Figure 1)

These supporting tools are available at local distributors

http://www.austriamicrosystems.com/06contactcenter/sales_start.htm

or can be ordered online:

http://www.austriamicrosystems.com/03products/products_detail/AS5045/description_AS5045.htm

8 AS5045 Demoboard

The AS5045 Demoboard is a complete rotary encoder system with built-in microcontroller, USB interface, 4-digit 7-segment display, a LED displaying the PWM output and two magnet status LEDs.

It also supports external AS5045 applications, such as the AS5045 adapter PCB or in-system AS5045 customer applications that can be connected to the demoboard and displayed, modified and permanently programmed using the AS5045 Demoboard Software.

The AS5045 demoboard can be used in several ways:

8.1.1 as standalone unit supplied by a 9V-battery

Connect a 7,5V..12V supply to pins "GND" and "+9V" at the right side of the board. No other connections are required

8.1.2 as standalone unit supplied by an USB port

Connect the demoboard to a PC using a USB cable (included in demoboard shipment). The board is supplied by the 5V supply of the USB port. No other connections are required

8.1.3 as input device for the AS5045 demoboard software

This configuration uses the same hardware connection as 8.1.2, but additionally the AS5045 demoboard software is running. All indicators on the demoboard will be displayed on the PC screen as well.

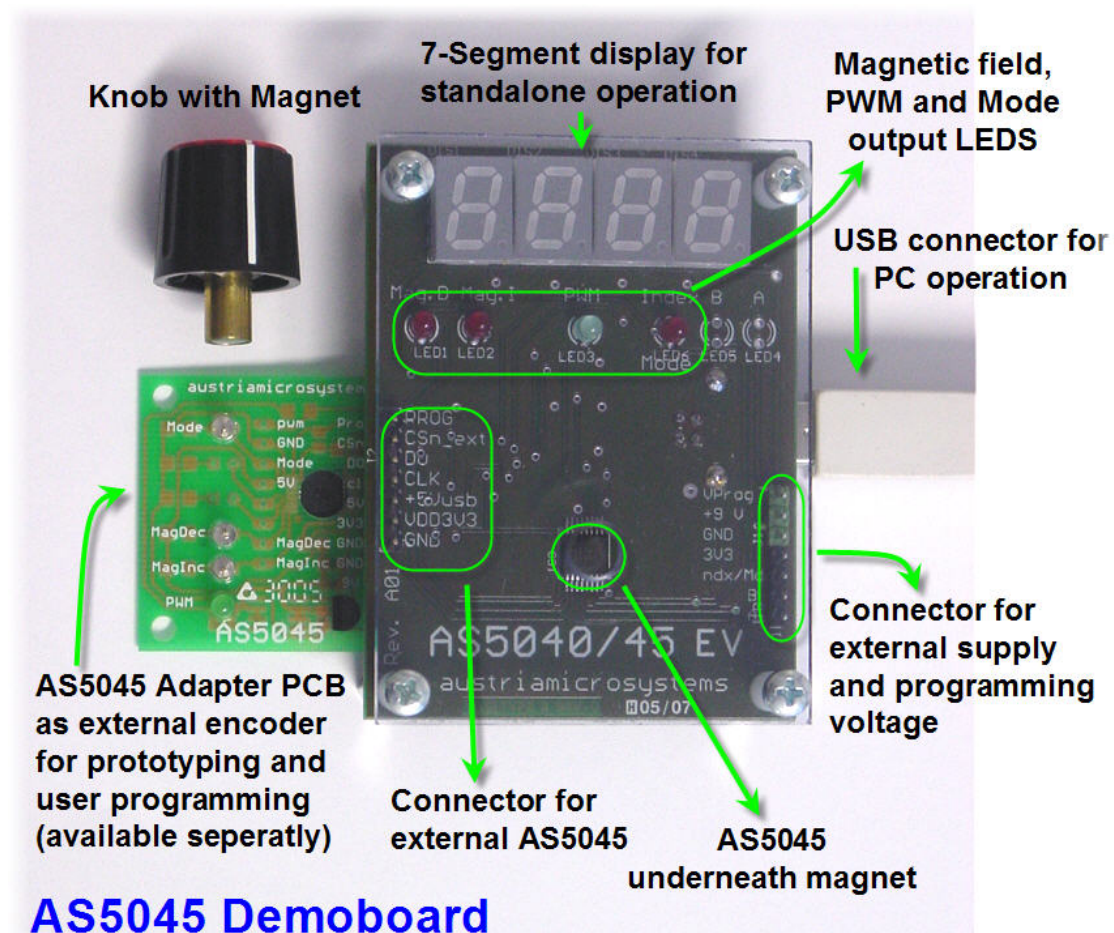

Figure 8: AS5045 demoboard and Adapter PCB

9 AS5045 Demoboard Software

The AS5045 Demoboard Software can be downloaded for free from the Internet at:

http://www.austriamicrosystems.com/03products/products_detail/AS5045/download_AS5045.htm?#software

It has several indicators and extra features, such as:

- Displaying the absolute angle as 12bit-word (0..4095), as absolute angle and as rotary dial
- Displaying the pulse-width-modulated (PWM) output as bar-graph
- Displaying the Push-Button functionality (MagCompEn)
- Putting the AS5045 in Alignment mode
- Permanently programming (OTP) the zero position or CCW bit.
- Reversing the direction of rotation

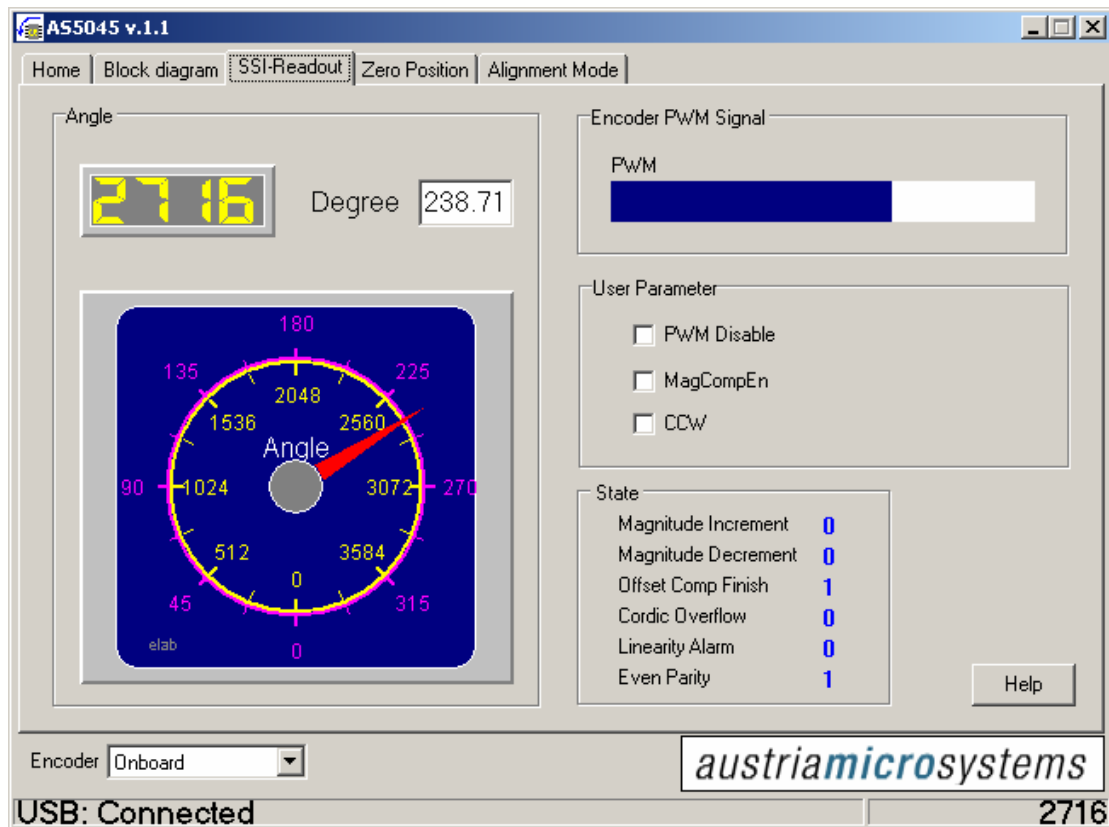

Further information on the AS5045 Demoboard Software is available in the AS5045 Demoboard Operation Manual (see: 7 Supporting Tools)

9.1 Connecting the AS5045 adapter PCB to the demoboard

The AS5045 Adapter PCB is intended as a standalone device that allows easy and quick testing of the AS5045 without the need of having to make your own PCB.

It allows access to each IC pin via a standard 100mil pitch, 600mil Dual-In-Line connector, has LEDs on all digital outputs and comes with an onboard 5V linear voltage regulator (78L05) and a battery clip to supply the board from a 9V battery.

The 7-pin female connector is designed to fit directly onto the AS5045 Demoboard and use the Adapter PCB as external encoder (software setting: Encoder = external).

The demoboard however, runs at 3.3V supply voltage. The Adapter PCB is configured for 5V supply voltage. Connecting both boards without modifications will not harm any of the boards, but may lead to data transmission errors due to the different digital levels, especially when an extension cable is used between demoboard and Adapter PCB.

If you use the Adapter PCB as external encoder for the AS5045 demoboard with an extension cable or experience data transmission errors, it is requested to configure the Adapter PCB for 3.3V supply voltage.

9.1.1 Modifications to operate the adapter board at 3.3V

Perform the following modifications:

- disconnect the 5V supply between Demoboard and Adapter PCB: remove or cut off pin "+5VUSB" at the bottom of the AS5045 demoboard
- connect pins "3V3" and "5V" on the Adapter PCB. Ideally, connect the pins right at the bottom of the 7pin female connector with a piece of wire or solder joint.
- you may also remove the 78L05 voltage regulator from the Adapter PCB to prevent accidental damage of the IC when an input voltage is applied to the regulator (and the 5V output is fed to the VDD3V3 supply pin)

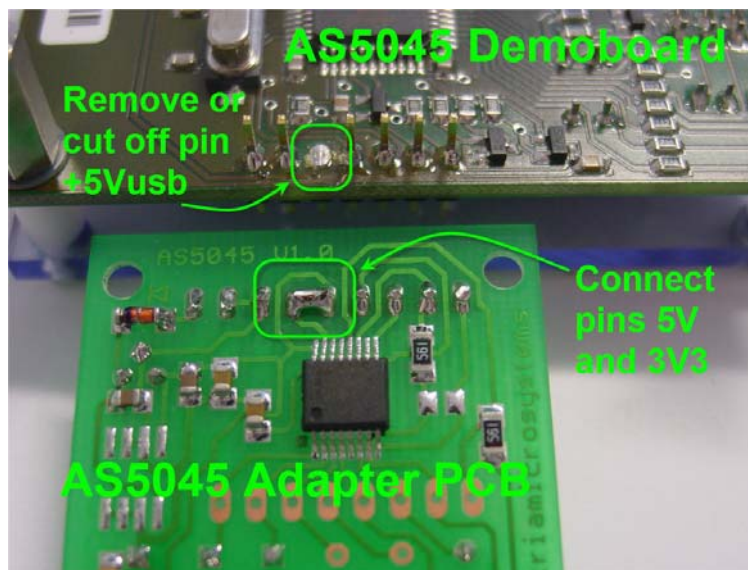

Figure 9: Configuring the Adapter PCB for 3.3V operation (See Figure 10)

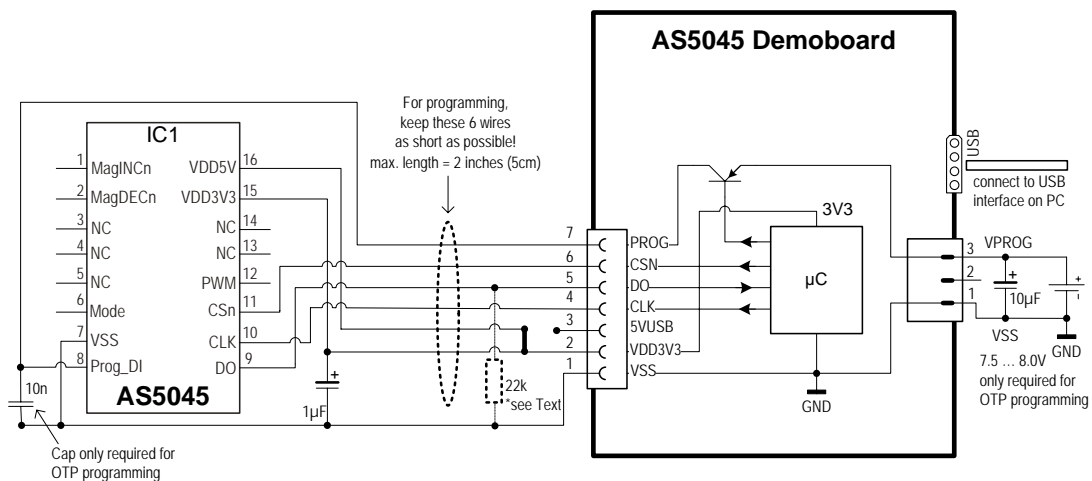

Figure 10: Connecting an external AS5045 application to the demoboard (See Figure 9)

** If longer cables are used, a pull-down resistor at the DO line of 22k - 56k Ohms is recommended to discharge the signal between data transmissions and no static voltage is built up.*

9.2 Reading the Adapter PCB with the AS5045 Demoboard Software:

Further information on the AS5045 Demoboard Software is available in the AS5045 Demoboard Operation Manual (see: 7 Supporting Tools)

The AS5045 Adapter PCB can be read as "external encoder" in the same way as the internal encoder. Switching from internal to external encoder can be done on the bottom left corner of the demoboard software screen : Encoder = onboard / external. Additionally, when Encoder = external is selected, the buttons "Permanent write" and "Read" are enabled in the "Zero Position" and "Incremental Mode" screens to allow OTP programming of the external encoder

Changing the Zero Position:

The programming options zero position and ccw operation can be modified at any time during normal operation. Permanently programming these registers will set the default setting after power-up. Programmed settings can again be modified during normal operation but will be reset to default when the power supply is disconnected.

OTP programming of the external AS5045 encoder:

To program the external AS5045 encoder, a programming voltage of 7.5 to 8V DC (130mA) must be applied to pins Vzapp and GND of the 3-pin connector at the right hand side of the demoboard. A 10 μ F buffer cap is recommended for this voltage (see Figure 10).

Programming is not recommended with long wires between demoboard and external encoder, as the inductance of the cable may generate high voltage spikes, that can cause wrong programming or even harm the IC. The maximum wire length between the demoboard connector and the PROG pin of the external encoder should be 50mm (2"). Additionally, a 10nF ceramic capacitor should be connected close to pin PROG and VSS.

An OTP (one time programming) cycle is automatically initiated, when button "Permanent write" is pressed. The default (non-programmed) logic state is "0" , consequently the programmed logic state is "1". It is possible to write "1"s into the OTP register at subsequent programming cycles. However, a programmed "1" cannot be cleared any more after programming.

Note that the chip will not be programmed, as long as no programming voltage is applied to Vzapp, although the software will issue a warning message that the chip will be permanently programmed.

10 Contact

Headquarters
austriamicrosystems AG
A 8141 Schloss Premstätten, **Austria**
Phone: +43 3136 500 0
Fax: +43 3136 525 01
industry.medical@austriamicrosystems.com
www.austriamicrosystems.com

10.1 Sales Offices

austriamicrosystems Germany GmbH
Tegernseer Landstrasse 85
D-81539 München, **Germany**
Phone: +49 89 69 36 43 0
Fax: +49 89 69 36 43 66

austriamicrosystems Italy S.r.l.
Via A. Volta, 18
I-20094 Corsico (MI), **Italy**
Phone: +39 02 4586 4364
Fax: +39 02 4585 773

austriamicrosystems France S.A.R.L.
124, Avenue de Paris
F-94300 Vincennes, **France**
Phone: +33 1 43 74 00 90
Fax: +33 1 43 74 20 98

austriamicrosystems Switzerland AG
Rietstrasse 4
CH 8640 Rapperswil, **Switzerland**
Phone: +41 55 220 9008
Fax: +41 55 220 9001

austriamicrosystems UK, Ltd.
88, Barkham Ride,
Finchampstead, Wokingham
Berkshire RG40 4ET, **United Kingdom**
Phone: +44 118 973 1797
Fax: +44 118 973 5117

austriamicrosystems AG
Klaavuntie 9 G 55
FI 00910 Helsinki, **Finland**
Phone: +358 9 72688 170
Fax: +358 9 72688 171

austriamicrosystems AG
Bivågen 3B
S 19163 Sollentuna, **Sweden**
Phone: +46 8 6231 710

austriamicrosystems USA, Inc.
8601 Six Forks Road
Suite 400
Raleigh, NC 27615, **USA**
Phone: +1 919 676 5292
Fax: +1 509 696 2713

austriamicrosystems USA, Inc.
4030 Moorpark Ave
Suite 116
San Jose, CA 95117, **USA**
Phone: +1 408 345 1790
Fax: +1 509 696 2713

austriamicrosystems AG
Suite 811, Tsimshatsui Centre
East Wing, 66 Mody Road
Tsim Sha Tsui East, Kowloon, **Hong Kong**
Phone: +852 2268 6899
Fax: +852 2268 6799

austriamicrosystems AG
AIOS Gotanda Annex 5th Fl., 1-7-11,
Higashi-Gotanda, Shinagawa-ku
Tokyo 141-0022, **Japan**
Phone: +81 3 5792 4975
Fax: +81 3 5792 4976

austriamicrosystems AG
#805, Dong Kyung Bldg.,
824-19, Yeok Sam Dong,
Kang Nam Gu, Seoul
Korea 135-080
Phone: +82 2 557 8776
Fax: +82 2 569 9823

austriamicrosystems AG
Singapore Representative Office
83 Clemenceau Avenue, #02-01 UE Square
239920, **Singapore**
Phone: +65 68 30 83 05
Fax: +65 62 34 31 20

11 Revision History

Revision	Date	Description
A02	Jul. 04, 2006	Figure 7: AS5045 adapter board dimensions.
A01	Jan.16, 2006	Creation

12 Copyright

Devices sold by austriamicrosystems are covered by the warranty and patent indemnification provisions appearing in its Term of Sale. austriamicrosystems makes no warranty, express, statutory, implied, or by description regarding the information set forth herein or regarding the freedom of the described devices from patent infringement. austriamicrosystems reserves the right to change specifications and prices at any time and without notice. Therefore, prior to designing this product into a system, it is necessary to check with austriamicrosystems for current information. This product is intended for use in normal commercial applications.

Copyright © 2006 austriamicrosystems. Trademarks registered ®. All rights reserved. The material herein may not be reproduced, adapted, merged, translated, stored, or used without the prior written consent of the copyright owner. To the best of its knowledge, austriamicrosystems asserts that the information contained in this publication is accurate and correct. However, austriamicrosystems shall not be liable to recipient or any third party for any damages, including but not limited to personal injury, property damage, loss of profits, loss of use, interruption of business or indirect, special, incidental or consequential damages, of any kind, in connection with or arising out of the furnishing, performance or use of the technical data herein. No obligation or liability to recipient or any third party shall arise or flow out of austriamicrosystems rendering of technical or other services.

austriamicrosystems
a leap ahead



Стандарт Электрон Связь

Мы молодая и активно развивающаяся компания в области поставок электронных компонентов. Мы поставляем электронные компоненты отечественного и импортного производства напрямую от производителей и с крупнейших складов мира.

Благодаря сотрудничеству с мировыми поставщиками мы осуществляем комплексные и плановые поставки широчайшего спектра электронных компонентов.

Собственная эффективная логистика и склад в обеспечивает надежную поставку продукции в точно указанные сроки по всей России.

Мы осуществляем техническую поддержку нашим клиентам и предпродажную проверку качества продукции. На все поставляемые продукты мы предоставляем гарантию .

Осуществляем поставки продукции под контролем ВП МО РФ на предприятия военно-промышленного комплекса России , а также работаем в рамках 275 ФЗ с открытием отдельных счетов в уполномоченном банке. Система менеджмента качества компании соответствует требованиям ГОСТ ISO 9001.

Минимальные сроки поставки, гибкие цены, неограниченный ассортимент и индивидуальный подход к клиентам являются основой для выстраивания долгосрочного и эффективного сотрудничества с предприятиями радиоэлектронной промышленности, предприятиями ВПК и научно-исследовательскими институтами России.

С нами вы становитесь еще успешнее!

Наши контакты:

Телефон: +7 812 627 14 35

Электронная почта: sales@st-electron.ru

Адрес: 198099, Санкт-Петербург,
Промышленная ул, дом № 19, литера Н,
помещение 100-Н Офис 331