

Applications

- Commercial and Military Radar
- Communications
- Electronic Warfare
- Test Instruments
- General Purpose
- High Power Switching

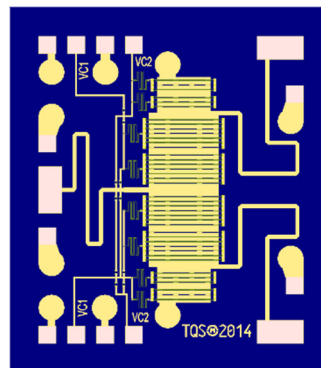

Product Features

- Frequency Range: 0.5 - 6 GHz
- Insertion Loss: ≤ 0.8 dB
- Power Handling: 46 dBm (P.1dB)
- Return Loss: > 15 dB
- Isolation: > 26 dB
- Control Voltages: 0 V/-40 V (from either side of the MMIC)
- Switching Speed: < 50 ns
- Reflective Switch
- Die Dimensions: 1.397 mm x 1.580 mm x 0.10 mm

Functional Block Diagram

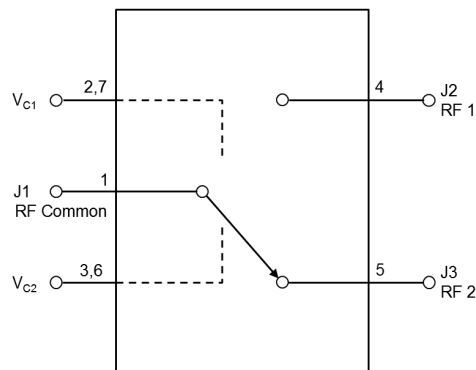

General Description

The TriQuint TGS2354 is a Single-Pole, Double-Throw (SPDT) reflective switch fabricated on TriQuint's TQGaN25 0.25um GaN on SiC production process.

Operating from 0.5 to 6GHz, the TGS2354 typically supports up to 40W input power handling at control voltages of 0/-40 V. This switch maintains low insertion loss of 0.8 dB or less, and greater than 25dB isolation making it ideal for high power switching applications across both defense and commercial platforms..

The TGS2354 is available in a small 1.397 x 1.58 mm die size and allows control voltage input from either side of the die. This, along with the minimal DC power consumption, allows for easy system integration.

Lead-free and RoHS compliant.

Evaluation boards available on request.

Pad Configuration

Pad No.	Symbol
1	RFC
2, 7	VC1
3, 6	VC2
4	RF1
5	RF2

Ordering Information

Part	ECCN	Description
TGS2354	EAR99	0.5-6 GHz 40 Watt GaN Switch

Absolute Maximum Ratings

Parameter	Value
Control Voltage (V _c)	-50 V
Control Current (I _c)	-1.0 / +1.0 mA
Power Dissipation (CW)	15 W
RF Input Power (CW)	46.5 dBm
Channel Temperature, T _{CH}	275 °C
Mounting Temperature (30 sec)	320 °C
Storage Temperature	-55 to 150 °C

Operation of this device outside the parameter ranges given above may cause permanent damage. These are stress ratings only, and functional operation of the device at these conditions is not implied.

Recommended Operating Conditions

Parameter	Min	Typ	Max	Units
Frequency	0.5		6	GHz
Input Power Handling (CW)		≤ 46		dBm
Control Voltage		-40		V
Channel Temp., T _{ch}		≤ 225		°C

Electrical specifications are measured at specified test conditions. Specifications are not guaranteed over all recommended operating conditions.

Electrical Specifications

Test conditions unless otherwise noted: T_{BASE} = 25 °C, CW Input Power

Parameter	Min	Typical	Max	Units
Operational Frequency Range	0.5		6.0	GHz
P-0.1dB (CW)		46		dBm
Control Current (I _c)		0.1		mA
Insertion Loss (On-State, 0.5-4 GHz)		< 0.5		dB
Insertion Loss (On-State, 4-8 GHz)		< 0.8		dB
Input Return Loss – On-State (Common Port RL)		> 15		dB
Output Return Loss – On-State (Switched Port RL)		> 15		dB
Isolation (Off-State)		> 26		dB
Output Return Loss – Off-State (Isolated Port RL)		2.3		dB
Third Order IM Distortion (V _c =-40V)		< -48		dBc
Switching Speed (10%-90/90-10%, V _c =-20V)		< 50		ns
Control Voltage		-40	-48	V
Insertion Loss Temperature Coefficient		0.003		dB/ °C

Thermal and Reliability Information

Parameter	Test Conditions	Value	Units
Thermal Resistance (θ_{JC}) ⁽¹⁾	$T_{BASE} = 85^\circ\text{C}$, $V_{C1} = 0\text{ V}$, $V_{C2} = -40\text{ V}$, $P_{IN} = 40\text{ W}$, $P_{DISS} = 12\text{ W}$	7.92	$^\circ\text{C/W}$
Channel Temperature (T_{CH})		180	$^\circ\text{C}$
Median Lifetime (T_M)		8.00E07	Hrs

Notes:

- MMIC soldered to 40 mil thick Cu-Mo carrier plate using 1.5 mil thick AuSn solder. Thermal resistance is determined from the channel to the back of the carrier plate (fixed 85 $^\circ\text{C}$ temp.).

Median Lifetime

Test Conditions: 40 V; Failure Criteria = 10% reduction in $I_{D\text{ MAX}}$

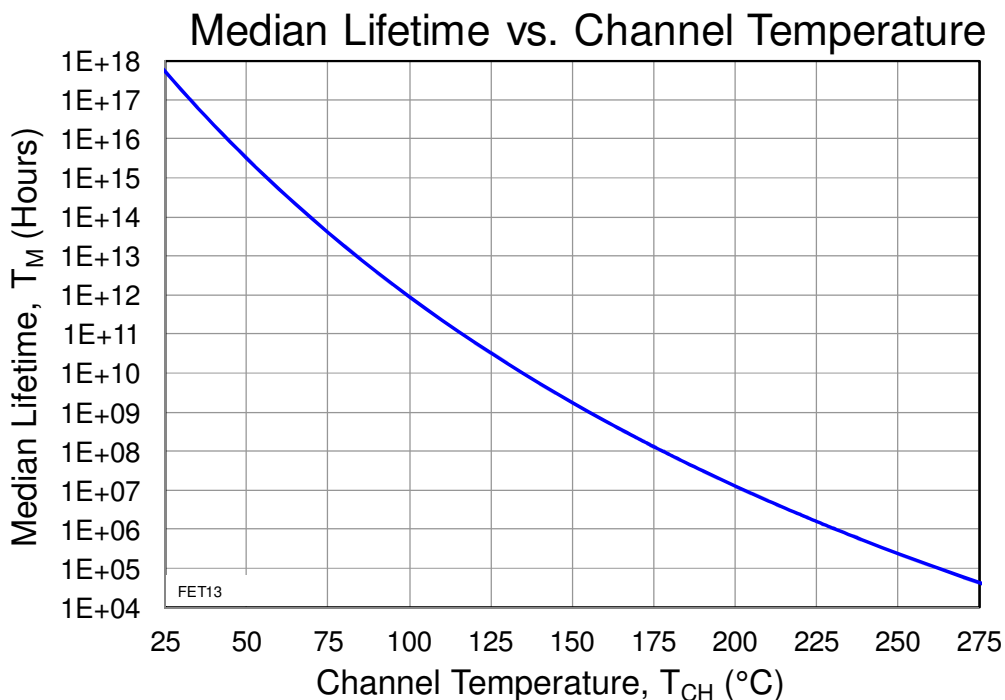

Typical Performance

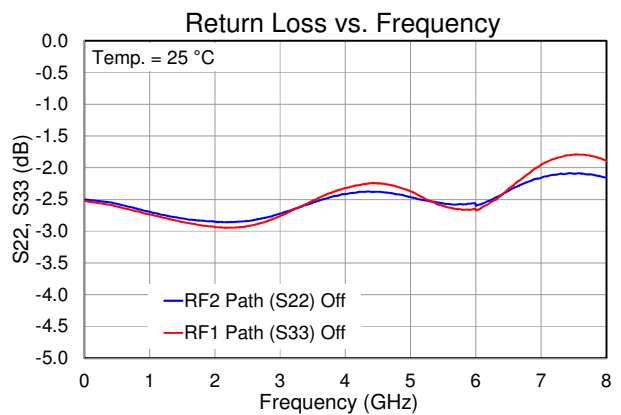
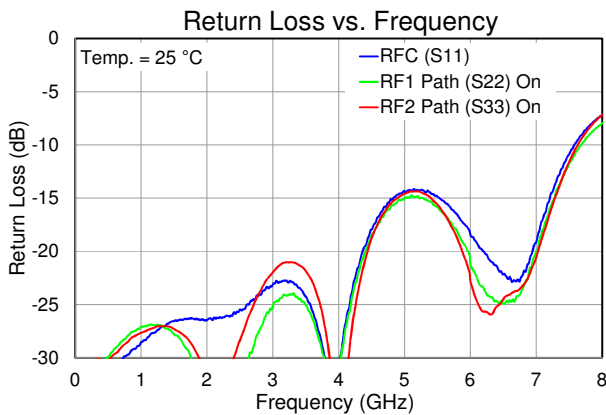
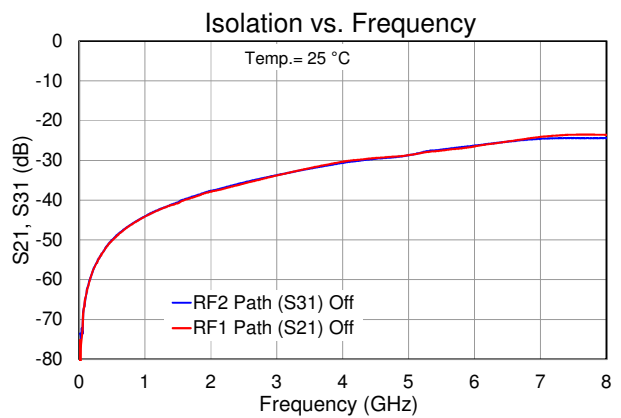
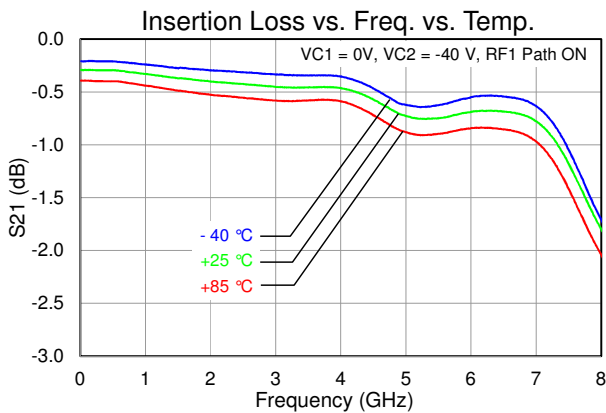
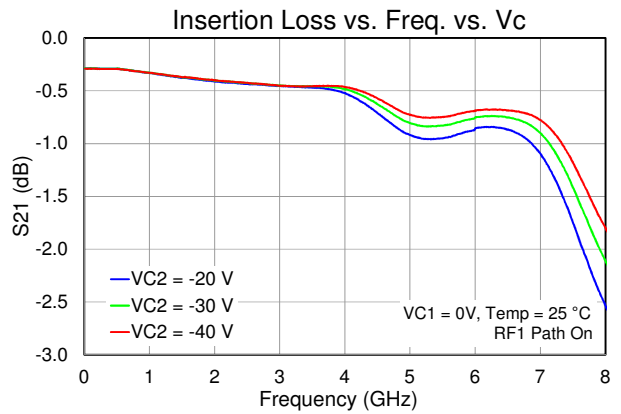
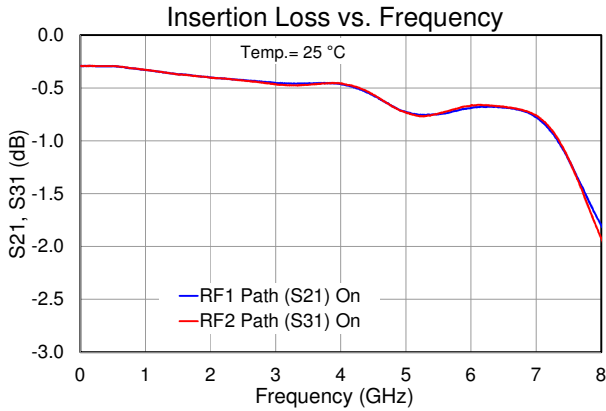

Typical Performance

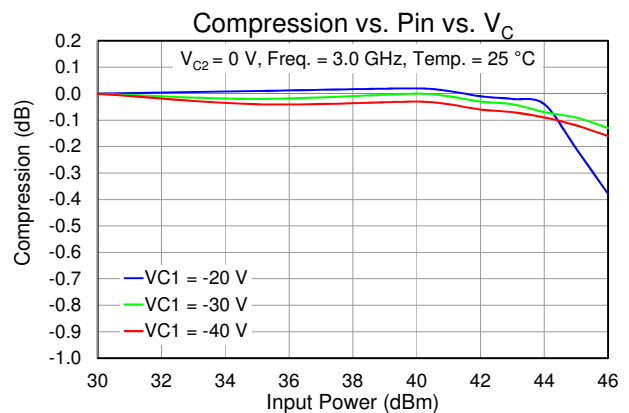
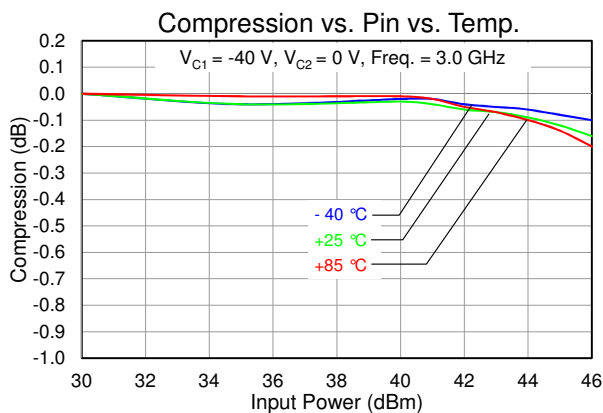
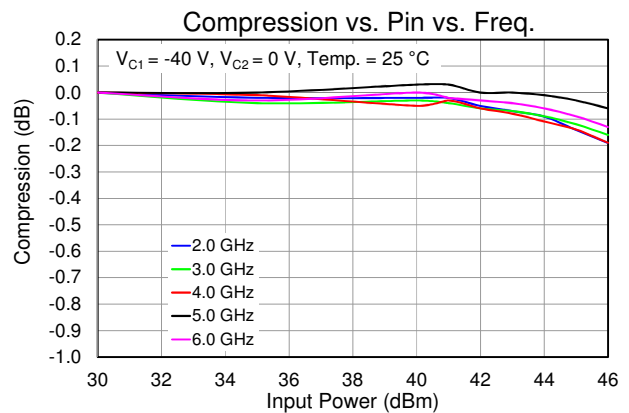
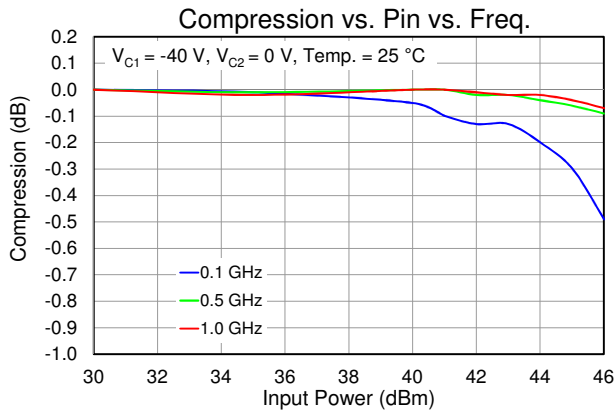

Typical Performance

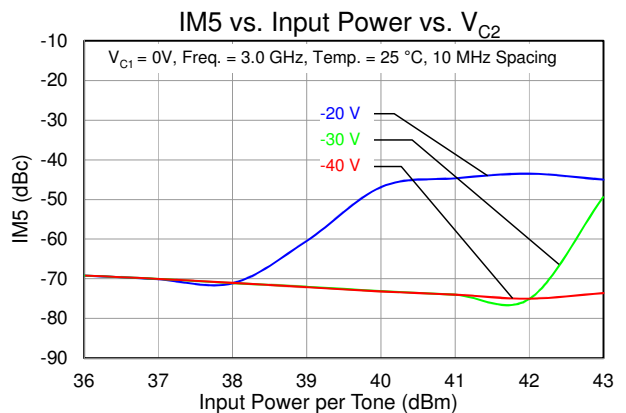
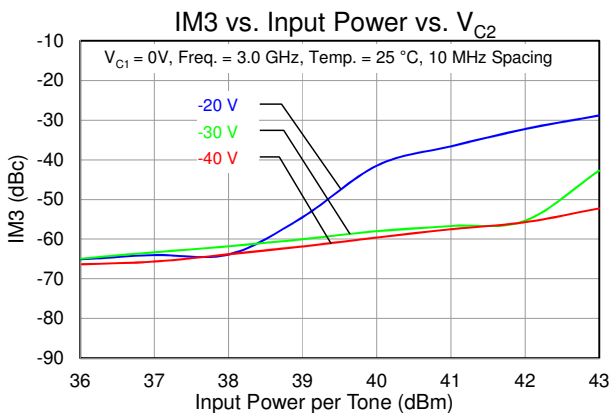
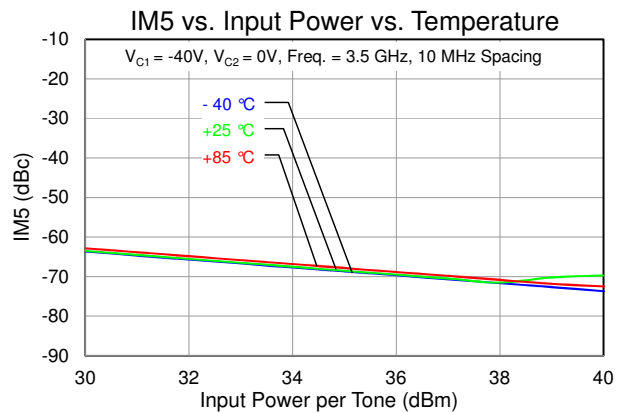
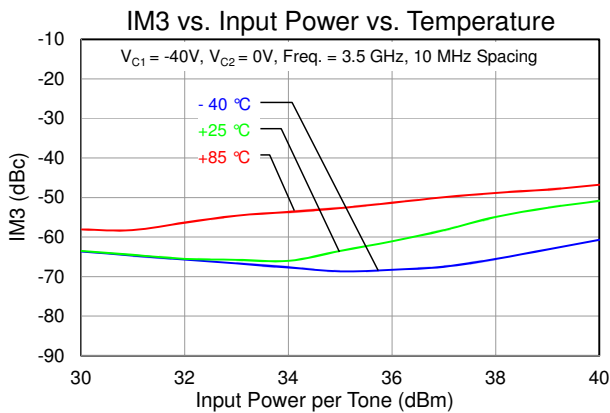
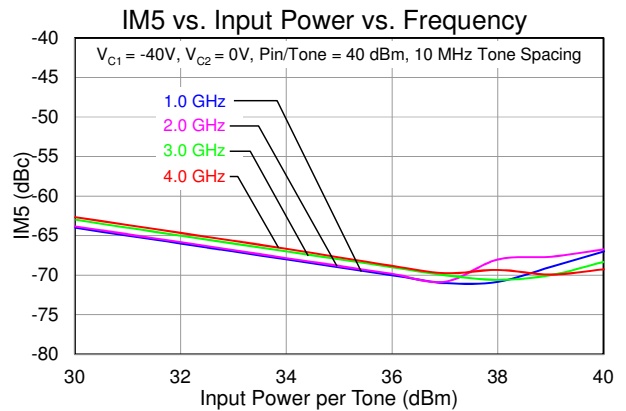
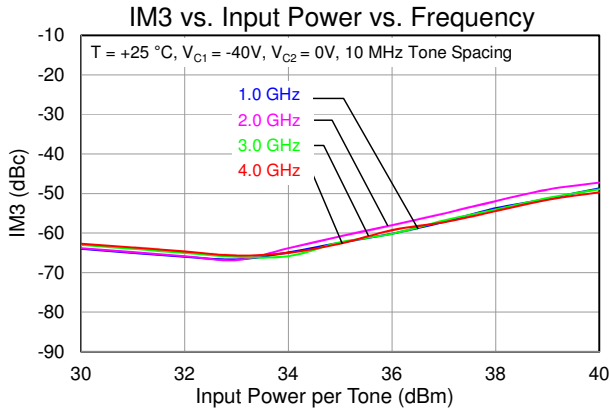

Application Circuit

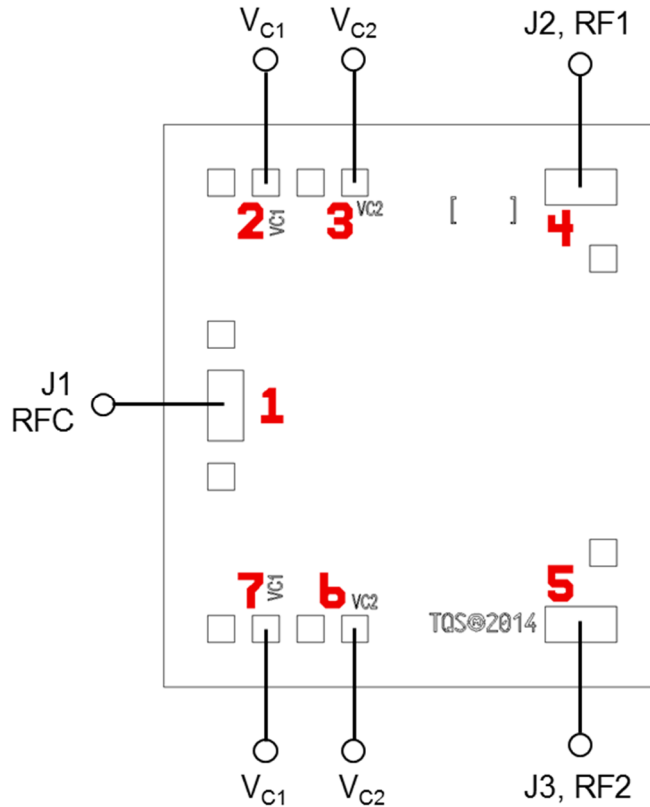

Notes:

DC blocking capacitors are required on all RF ports.

VC1 can be biased from either bond pad 2 or 7, and the non-biased bond pad can be left open. VC2 can be biased from either bond pad 3 or 6, and the non-biased bond pad can be left open.

This switch can be configured as a Single Pole, Single Throw (SPST) by terminating one unused RF switched port with a 50 Ohm load.

Function Table

RF Path	State	V _{c1}	V _{c2}
RFC to RF1	On-State (Insertion Loss)	0 V	-40 V
	Off-State (Isolation)	-40 V	0 V
RFC to RF2	On-State (Insertion Loss)	-40 V	0 V
	Off-State (Isolation)	0 V	-40 V

Evaluation Board

RF Layer is 0.010" thick Rogers Corp. RO4350B, $\epsilon_r = 3.48$. Metal layers are 0.5 oz. copper. The microstrip line at the connector interface is optimized for the Southwest Microwave end launch connector 1092-02A-5.

The pad pattern shown has been developed and tested for optimized assembly at TriQuint Semiconductor. The PCB land pattern has been developed to accommodate lead and package tolerances. Since surface mount processes vary from company to company, careful process development is recommended.

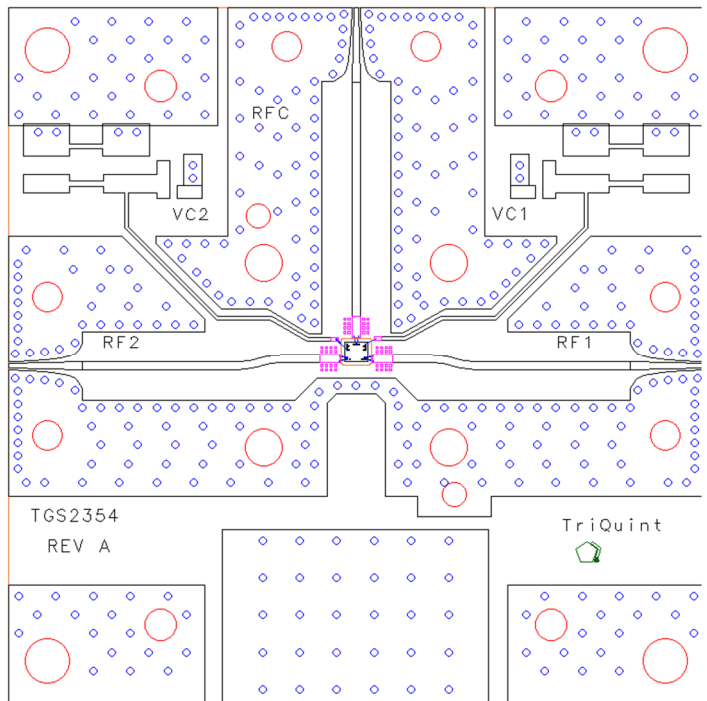

Mounting Detail

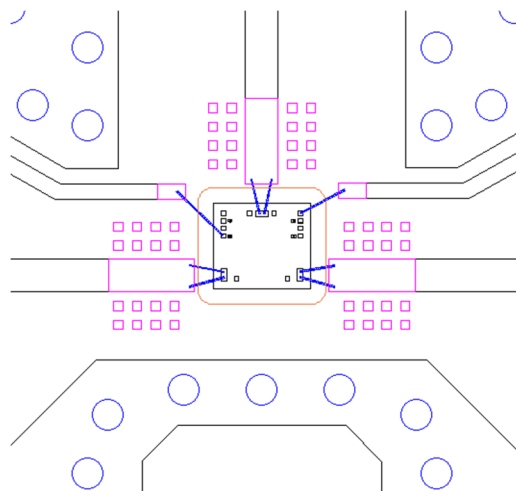

Note: MMIC die is mounted directly to carrier plate in the cutout of the EVB.

Mechanical Drawing & Bond Pad Description

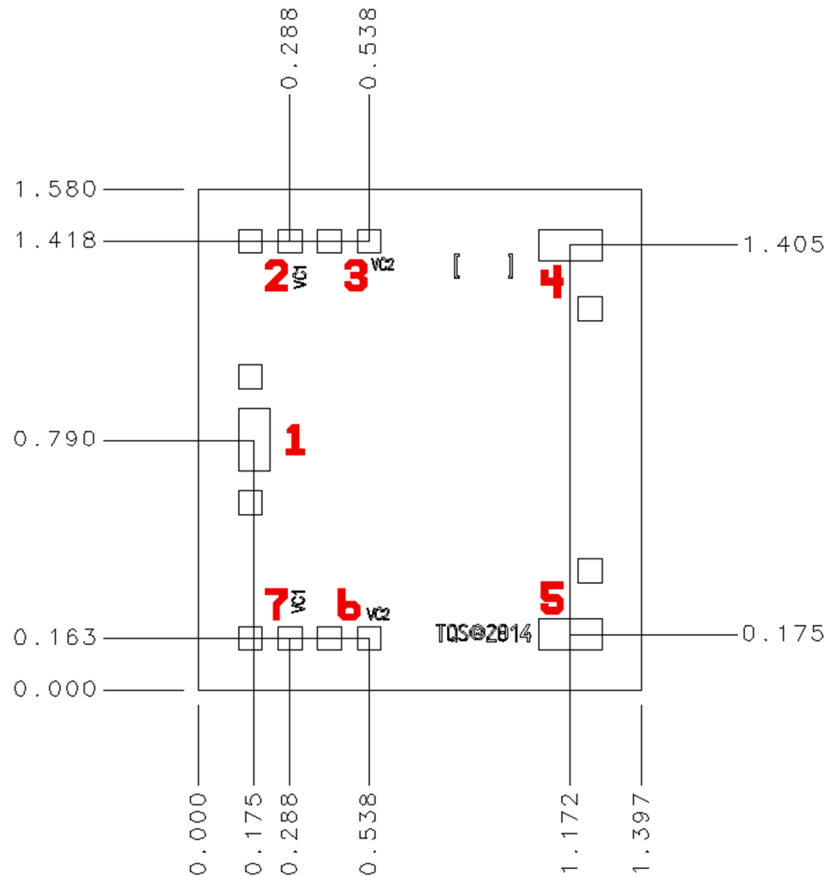

Unit: millimeters
 Thickness: 0.10
 Die x, y size tolerance: +/- 0.050
 Chip edge to bond pad dimensions are shown to center of pad
 Ground is backside of die

Bond Pad	Symbol	Description
1	RF1	RF common port; matched to 50 Ω; DC coupled
2, 7	VC1	Control voltage 1
3, 6	VC2	Control voltage 2
4	RF2	RF switched port 1; matched to 50 Ω; DC coupled
5	RF2	RF switched port 2; matched to 50 Ω; DC coupled

Assembly Notes

Component placement and adhesive attachment assembly notes:

- Vacuum pencils and/or vacuum collets are the preferred method of pick up.
- Air bridges must be avoided during placement.
- The force impact is critical during auto placement.
- Organic attachment (i.e., conductive epoxy) can be used in low-power applications.
- Curing should be done in a convection oven; proper exhaust is a safety concern.

Reflow process assembly notes:

- Use AuSn (80/20) solder and limit exposure to temperatures above 300°C to 3-4 minutes, maximum.
- An alloy station or conveyor furnace with reducing atmosphere should be used.
- Do not use any kind of flux.
- Coefficient of thermal expansion matching is critical for long-term reliability.
- Devices must be stored in a dry nitrogen atmosphere.

Interconnect process assembly notes:

- Thermosonic ball bonding is the preferred interconnect technique.
- Force, time, and ultrasonics are critical parameters.
- Aluminum wire should not be used.
- Devices with small pad sizes should be bonded with 0.0007-inch wire.

Product Compliance Information

ESD Sensitivity Ratings



Caution! ESD-Sensitive Device

ESD Rating: TBD
Value: TBD
Test: Human Body Model (HBM)
Standard: JEDEC Standard JESD22-A114

ECCN

US Department of Commerce: EAR99

Solderability

Use only AuSn (80/20) solder and limit exposure to temperatures above 300 °C to 3-4 minutes, maximum.

RoHS-Compliance

This part is compliant with EU 2002/95/EC RoHS directive (Restrictions on the Use of Certain Hazardous Substances in Electrical and Electronic Equipment).

This product also has the following attributes:

- Lead Free
- Halogen Free (Chlorine, Bromine)
- Antimony Free
- TBBP-A (C₁₅H₁₂Br₄O₂) Free
- PFOS Free
- SVHC Free

Contact Information

For the latest specifications, additional product information, worldwide sales and distribution locations, and information about TriQuint:

Web: www.triquint.com
Email: info-sales@triquint.com

Tel: +1.972.994.8465
Fax: +1.972.994.8504

For technical questions and application information: Email: info-products@triquint.com

Important Notice

The information contained herein is believed to be reliable. TriQuint makes no warranties regarding the information contained herein. TriQuint assumes no responsibility or liability whatsoever for any of the information contained herein. TriQuint assumes no responsibility or liability whatsoever for the use of the information contained herein. The information contained herein is provided "AS IS, WHERE IS" and with all faults, and the entire risk associated with such information is entirely with the user. All information contained herein is subject to change without notice. Customers should obtain and verify the latest relevant information before placing orders for TriQuint products. The information contained herein or any use of such information does not grant, explicitly or implicitly, to any party any patent rights, licenses, or any other intellectual property rights, whether with regard to such information itself or anything described by such information.

TriQuint products are not warranted or authorized for use as critical components in medical, life-saving, or life-sustaining applications, or other applications where a failure would reasonably be expected to cause severe personal injury or death.



Стандарт Электрон Связь

Мы молодая и активно развивающаяся компания в области поставок электронных компонентов. Мы поставляем электронные компоненты отечественного и импортного производства напрямую от производителей и с крупнейших складов мира.

Благодаря сотрудничеству с мировыми поставщиками мы осуществляем комплексные и плановые поставки широчайшего спектра электронных компонентов.

Собственная эффективная логистика и склад в обеспечивает надежную поставку продукции в точно указанные сроки по всей России.

Мы осуществляем техническую поддержку нашим клиентам и предпродажную проверку качества продукции. На все поставляемые продукты мы предоставляем гарантию .

Осуществляем поставки продукции под контролем ВП МО РФ на предприятия военно-промышленного комплекса России , а также работаем в рамках 275 ФЗ с открытием отдельных счетов в уполномоченном банке. Система менеджмента качества компании соответствует требованиям ГОСТ ISO 9001.

Минимальные сроки поставки, гибкие цены, неограниченный ассортимент и индивидуальный подход к клиентам являются основой для выстраивания долгосрочного и эффективного сотрудничества с предприятиями радиоэлектронной промышленности, предприятиями ВПК и научно-исследовательскими институтами России.

С нами вы становитесь еще успешнее!

Наши контакты:

Телефон: +7 812 627 14 35

Электронная почта: sales@st-electron.ru

Адрес: 198099, Санкт-Петербург,
Промышленная ул, дом № 19, литера Н,
помещение 100-Н Офис 331