

Low power GPS RF front-end

Data brief

Features

- Integrated LNA
- Low power consumption (< 25 mW)
- 1.8 V supply voltage
- GPS and Galileo compliant
- Minimum external components
- Serial interface
- 3 bits A/D converter
- CMOS 65 nm technology
- 2 kV HBM ESD protected
- Standard QFN-32 package

Description

The chip is a fully integrated RF front-end able to down-convert either the GPS L1 signal from 1575.42 MHz to 4.092 MHz.

The STA5630 embeds high performance LNA minimizing external component count. The chip uses state of the art CMOS 65 nm technology.

A 3-bit ADC converts the IF signal to Sign (SIGN) and Magnitude (MAG0 and MAG1). The magnitude bits are internally integrated in order to control the variable gain amplifiers. The VGA gain can be also set by the SPI interface.

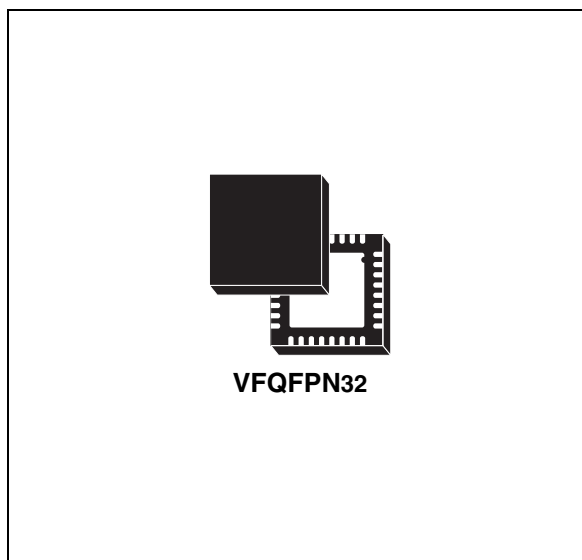

The STA5630 accepts a range of reference clocks (10 to 52 MHz) and generates a 16.368 MHz sampling clock (GPS_CLK) for the baseband. The STA5630 embeds LDO to supply the internal core of the device facilitating requirements to external power supply.

High performance low power and cost effective device, the STA5630 is the ideal solution for automotive, cellular and consumer battery powered applications.

Table 1. Device summary

Order code	Marking	Package	Packing
STA5630	STA5630	VFQFPN32	Tray
STA5630TR	STA5630	VFQFPN32	Tape and reel

Contents

1	Applications	3
	1.1 Block diagram	3
2	Pin description	4
3	Package information	5
4	Revision history	6

1 Applications

Three main applications cases are considered and described hereafter.

The first uses a passive antenna and only a single RF SAW in front of the internal LNA. It targets low cost and medium performance applications. In this case LNA is ON and RFA is set at minimum gain.

The second uses a passive antenna and two RF SAWs. It maximizes the performances in presence of severe blockers. In this case LNA is ON and RFA is set at maximum gain.

The third case uses an active antenna. This solution targets applications where the GPS antenna is far from the RF front-end. In this case the signal can be fed into either LNA or RFA input depending on the application conditions.

STA5630 is suitable for baseband requiring 16.368/4.092 clock/RF interface and one, two or three bits samples. It accepts reference clocks (TCXO) in the range of 10-52 MHz and delivers a TCXO buffered copy to the baseband.

The STA5630 has two default modes selectable by an external pin (MODE):

- MODE 0: the chip is configured to use 16.368 MHz as reference frequency,
- MODE 1: the chip is configured to use 26 MHz as reference frequency.

Other modes are programmed through the serial interface

1.1 Block diagram

Figure 1. Block diagram

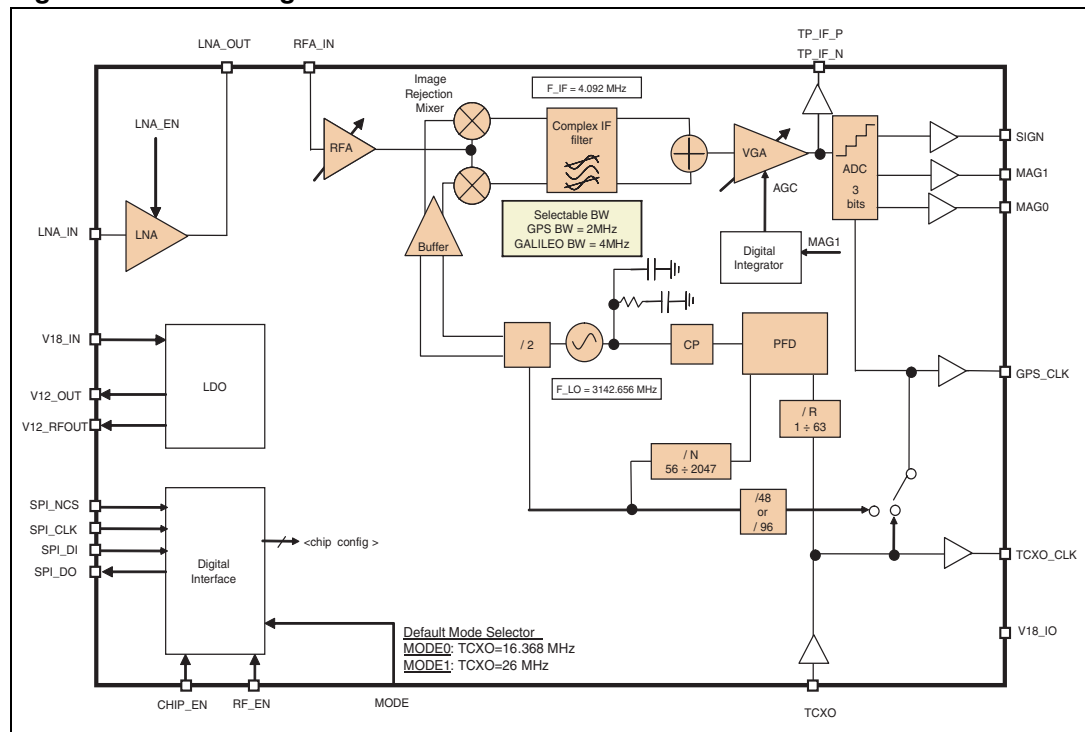

2 Pin description

Table 2. Pin list description

Pin #	Pin name	Description	Type
1	TP_IF_P	RF/IF receiver chain test positive output	Analog output
2	V12_RFA	RF amplifier (RFA) power supply (1.2V)	Supply pin
3	RFA_IN	RFA input, DC coupled	Analog input
4	V12_IF	IF section power supply (1.2V)	Supply pin
5	V12_OUT	LDO IF/DIG output. Power supply (1.2V) delivered for IF/ADC/DIG_TCXO/VCO/VDD_IO VCC	Output
6	V12_RF_OUT	LDO RF output: Power supply (1.2V) delivered for LNA/RFA/MIXER VCC	Output
7	V18_IN	LDOs power supply (1.8V)	Supply pin
8	V12_LNA	Low noise amplifier (LNA) power supply (1.2V)	Supply pin
9	LNA_OUT	LNA output	Analog output
10	GND	Ground	Ground
11	LNA_IN	LNA input, DC coupled	Analog input
12	GND	Ground	Ground
13	CHIP_EN	Chip Enable	Digital input
14	MODE	Power-On Default Configuration Selector	Digital input
15	V18_IO	I/Os power supply (1.8V)	Supply pin
16	GPS_CLK	GPS clock (16.368MHz)	Digital output
17	MAG0	Mag0 data (Last significant bit)	Digital output
18	MAG1	Mag1 data	Digital output
19	SIGN	Sign data (most significant bit)	Digital output
20	SPI_CLK	Serial Parallel Interface Clock	Digital input
21	SPI_NCS	Serial Parallel Interface Chip Select (Active Low - 1.8V domain)	Digital input
22	SPI_DI	Serial Parallel Interface Data Input	Digital input
23	SPI_DO	Serial Parallel Interface Data Output	Digital output
24	TCXO_CLK	TCXO Buffered Output	Digital output
25	V12_IO	Power supply for I/Os digital section (1.2V)	Supply pin
26	GND_IO	I/Os Ground	Ground
27	TCXO_IN	TCXO Input, DC coupled	Analog input
28	V12_DIG	Digital section and TCXO buffer input power supply (1.2V)	Supply pin
29	V12_VCO	VCO power supply (1.2V)	Supply pin
30	V12_ADC	ADC section power supply (1.2V)	Supply pin
31	V12_MIX	Mixer power supply (1.2V)	Supply pin
32	TP_IF_N	RF/IF receiver chain test negative output	Analog output
EP	GND	Ground	Ground

3 Package information

In order to meet environmental requirements, ST offers these devices in different grades of ECOPACK® packages, depending on their level of environmental compliance. ECOPACK® specifications, grade definitions and product status are available at: www.st.com.

ECOPACK® is an ST trademark.

Figure 2. VFQFPN32 (5x5x1.0 mm) mechanical data and package dimensions

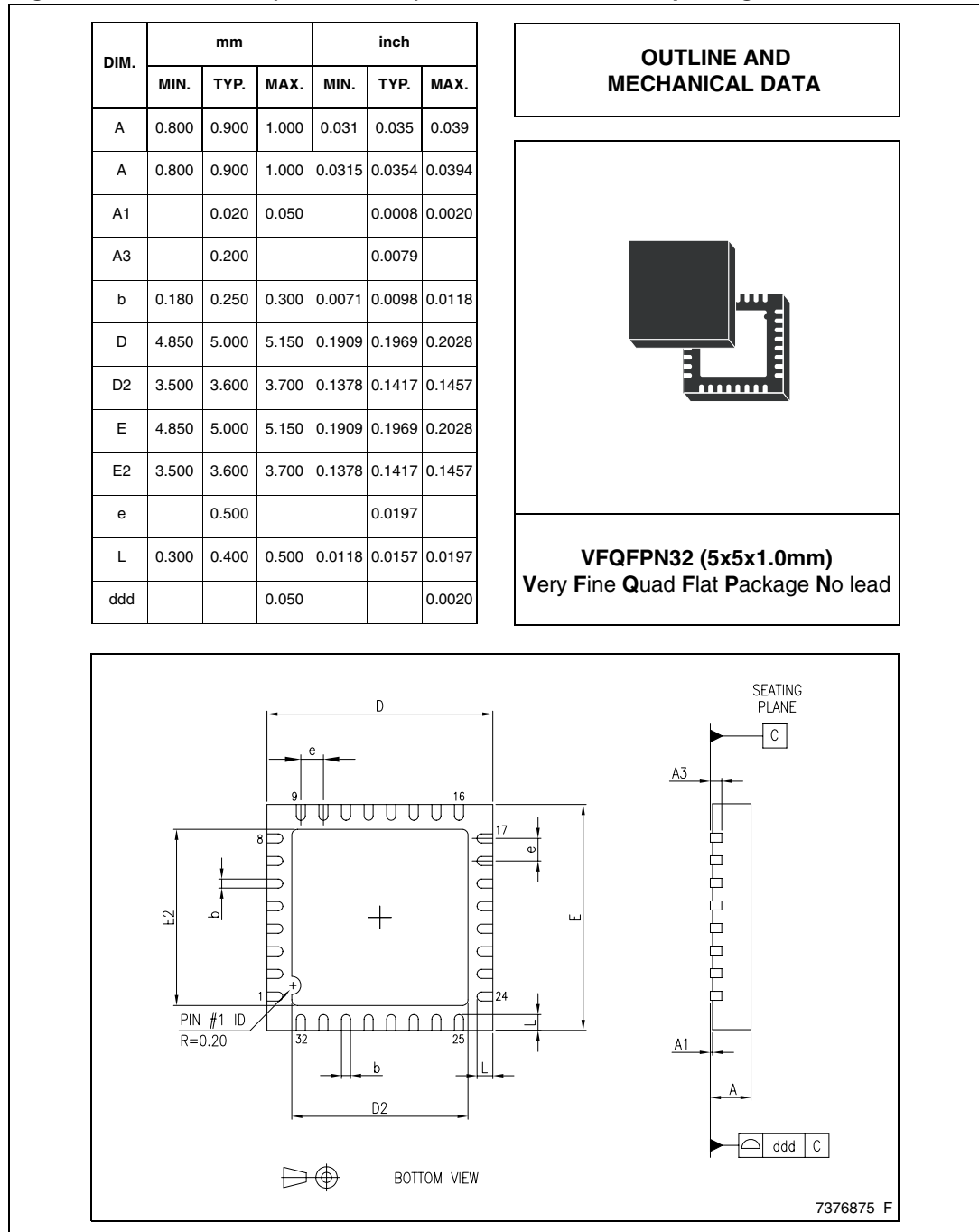

4 Revision history

Table 3. Document revision history

Date	Revision	Changes
22-Jul-2009	1	Initial release.

Please Read Carefully:

Information in this document is provided solely in connection with ST products. STMicroelectronics NV and its subsidiaries ("ST") reserve the right to make changes, corrections, modifications or improvements, to this document, and the products and services described herein at any time, without notice.

All ST products are sold pursuant to ST's terms and conditions of sale.

Purchasers are solely responsible for the choice, selection and use of the ST products and services described herein, and ST assumes no liability whatsoever relating to the choice, selection or use of the ST products and services described herein.

No license, express or implied, by estoppel or otherwise, to any intellectual property rights is granted under this document. If any part of this document refers to any third party products or services it shall not be deemed a license grant by ST for the use of such third party products or services, or any intellectual property contained therein or considered as a warranty covering the use in any manner whatsoever of such third party products or services or any intellectual property contained therein.

UNLESS OTHERWISE SET FORTH IN ST'S TERMS AND CONDITIONS OF SALE ST DISCLAIMS ANY EXPRESS OR IMPLIED WARRANTY WITH RESPECT TO THE USE AND/OR SALE OF ST PRODUCTS INCLUDING WITHOUT LIMITATION IMPLIED WARRANTIES OF MERCHANTABILITY, FITNESS FOR A PARTICULAR PURPOSE (AND THEIR EQUIVALENTS UNDER THE LAWS OF ANY JURISDICTION), OR INFRINGEMENT OF ANY PATENT, COPYRIGHT OR OTHER INTELLECTUAL PROPERTY RIGHT.

UNLESS EXPRESSLY APPROVED IN WRITING BY AN AUTHORIZED ST REPRESENTATIVE, ST PRODUCTS ARE NOT RECOMMENDED, AUTHORIZED OR WARRANTED FOR USE IN MILITARY, AIR CRAFT, SPACE, LIFE SAVING, OR LIFE SUSTAINING APPLICATIONS, NOR IN PRODUCTS OR SYSTEMS WHERE FAILURE OR MALFUNCTION MAY RESULT IN PERSONAL INJURY, DEATH, OR SEVERE PROPERTY OR ENVIRONMENTAL DAMAGE. ST PRODUCTS WHICH ARE NOT SPECIFIED AS "AUTOMOTIVE GRADE" MAY ONLY BE USED IN AUTOMOTIVE APPLICATIONS AT USER'S OWN RISK.

Resale of ST products with provisions different from the statements and/or technical features set forth in this document shall immediately void any warranty granted by ST for the ST product or service described herein and shall not create or extend in any manner whatsoever, any liability of ST.

ST and the ST logo are trademarks or registered trademarks of ST in various countries.

Information in this document supersedes and replaces all information previously supplied.

The ST logo is a registered trademark of STMicroelectronics. All other names are the property of their respective owners.

© 2009 STMicroelectronics - All rights reserved

STMicroelectronics group of companies

Australia - Belgium - Brazil - Canada - China - Czech Republic - Finland - France - Germany - Hong Kong - India - Israel - Italy - Japan - Malaysia - Malta - Morocco - Philippines - Singapore - Spain - Sweden - Switzerland - United Kingdom - United States of America

www.st.com



Стандарт Электрон Связь

Мы молодая и активно развивающаяся компания в области поставок электронных компонентов. Мы поставляем электронные компоненты отечественного и импортного производства напрямую от производителей и с крупнейших складов мира.

Благодаря сотрудничеству с мировыми поставщиками мы осуществляем комплексные и плановые поставки широчайшего спектра электронных компонентов.

Собственная эффективная логистика и склад в обеспечивает надежную поставку продукции в точно указанные сроки по всей России.

Мы осуществляем техническую поддержку нашим клиентам и предпродажную проверку качества продукции. На все поставляемые продукты мы предоставляем гарантию .

Осуществляем поставки продукции под контролем ВП МО РФ на предприятия военно-промышленного комплекса России , а также работаем в рамках 275 ФЗ с открытием отдельных счетов в уполномоченном банке. Система менеджмента качества компании соответствует требованиям ГОСТ ISO 9001.

Минимальные сроки поставки, гибкие цены, неограниченный ассортимент и индивидуальный подход к клиентам являются основой для выстраивания долгосрочного и эффективного сотрудничества с предприятиями радиоэлектронной промышленности, предприятиями ВПК и научно-исследовательскими институтами России.

С нами вы становитесь еще успешнее!

Наши контакты:

Телефон: +7 812 627 14 35

Электронная почта: sales@st-electron.ru

Адрес: 198099, Санкт-Петербург,
Промышленная ул, дом № 19, литера Н,
помещение 100-Н Офис 331