

General Description

The IDT6V31021 is a 4-output low- power differential buffer. Each output has its own OE# pin. It has a maximum operating frequency of 167 MHz and supports all SERDES clock frequencies for Freescale QorIQ CPUs.

Recommended Application

PCIe Gen1/2/3 or Ethernet Fanout Buffer, or any application requiring low additive phase jitter.

Output Features

- 4 - low power differential output pairs
- Individual OE# control of each output pair

Features/Benefits

- Low power differential outputs; power efficient
- Power down mode when all OE# are high; reduces system standby power
- Industrial temperature range; can be used in demanding environments
- 20-pin MFL; space savings

Key Specifications

- Output cycle-cycle jitter <15ps additive
- Output to Output skew: <50ps
- PCIe Gen3 additive phasejitter <0.3ps rms
- 10.3125G/64 additive phase jitter <100fs rms

Block Diagram

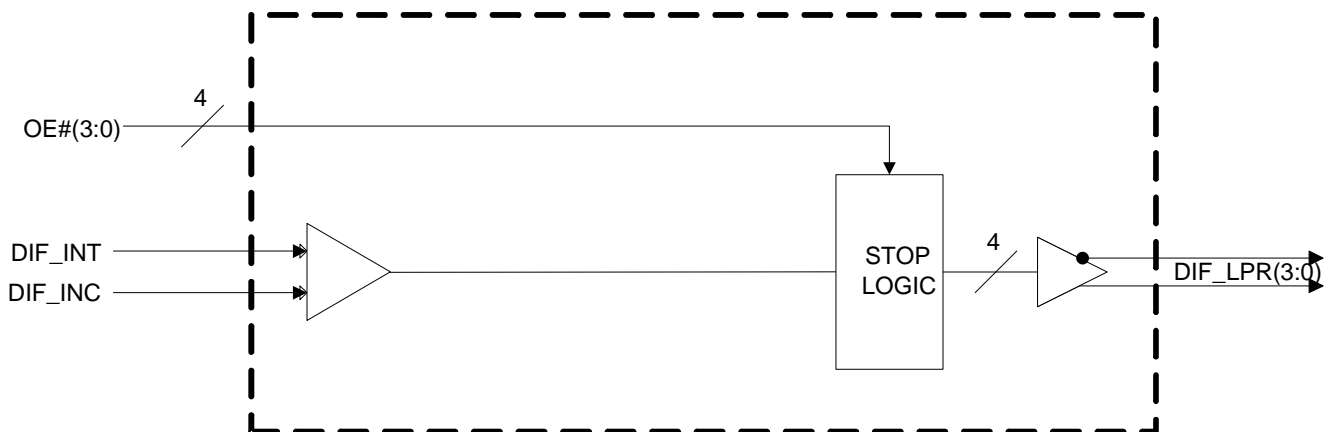

Pin Configuration

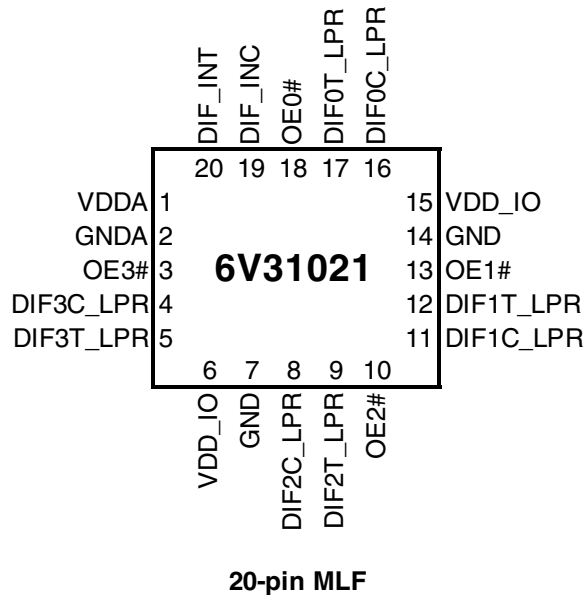

Power Connections

Pin Number (MLF)		Description
VDD	GND	
6,15	7,14	VDD_IO for DIF(3:0)
1	2	3.3V Analog VDD & GND

Terminations

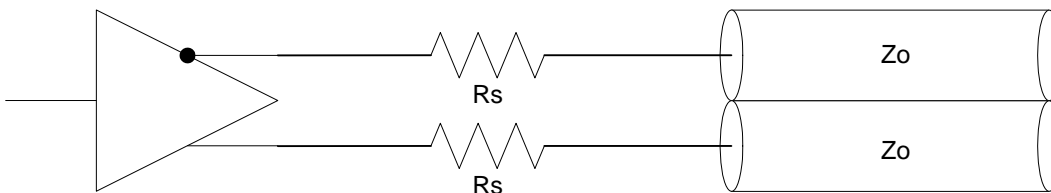

$Z_o - 17 = R_s$ (ohms), where Z_o is the single-ended intrinsic impedance of the board transmission line. Single-ended intrinsic impedance is $\frac{1}{2}$ that of the differential impedance.

Single Ended Impedance (Z_o)	R_s 5% tolerance	R_s 2% tolerance	Notes
50	33	33.2	In general, 5% resistors may be used. All values are in ohms.
45	27	27.4	
42.5	24 or 27	24.9	

Pin Descriptions

PIN #	PIN NAME	PIN TYPE	DESCRIPTION
1	VDDA	PWR	3.3V Power for the Analog Core
2	GND	GND	Ground for the Analog Core
3	OE3#	IN	Output Enable for DIF3 output. Control is as follows: 0 = enabled, 1 = Low-Low
4	DIF3C_LPR	OUT	Complement clock of low power differential clock pair. (no 50ohm shunt resistor to GND needed)
5	DIF3T_LPR	OUT	True clock of low power differential clock pair. (no 50ohm shunt resistor to GND needed)
6	VDD_IO	PWR	Power supply for low power differential outputs, nominal 1.05V to 3.3V
7	GND	GND	Ground pin
8	DIF2C_LPR	OUT	Complement clock of low power differential clock pair. (no 50ohm shunt resistor to GND needed)
9	DIF2T_LPR	OUT	True clock of low power differential clock pair. (no 50ohm shunt resistor to GND needed)
10	OE2#	IN	Output Enable for DIF2 output. Control is as follows: 0 = enabled, 1 = Low-Low
11	DIF1C_LPR	OUT	Complement clock of low power differential clock pair. (no 50ohm shunt resistor to GND needed)
12	DIF1T_LPR	OUT	True clock of low power differential clock pair. (no 50ohm shunt resistor to GND needed)
13	OE1#	IN	Output Enable for DIF1 output. Control is as follows: 0 = enabled, 1 = Low-Low
14	GND	GND	Ground pin
15	VDD_IO	PWR	Power supply for low power differential outputs, nominal 1.05V to 3.3V
16	DIF0C_LPR	OUT	Complement clock of low power differential clock pair. (no 50ohm shunt resistor to GND needed)
17	DIF0T_LPR	OUT	True clock of low power differential clock pair. (no 50ohm shunt resistor to GND needed)
18	OE0#	IN	Output Enable for DIF0 output. Control is as follows: 0 = enabled, 1 = Low-Low
19	DIF_INC	IN	Complement side of differential input clock
20	DIF_INT	IN	True side of differential input clock

Absolute Maximum Ratings

Stresses above the ratings listed below can cause permanent damage to the IDT6V31021. These ratings, which are standard values for IDT commercially rated parts, are stress ratings only. Functional operation of the device at these or any other conditions above those indicated in the operational sections of the specifications is not implied. Exposure to absolute maximum rating conditions for extended periods can affect product reliability. Electrical parameters are guaranteed only over the recommended operating temperature range.

PARAMETER	SYMBOL	CONDITIONS	MIN	TYP	MAX	UNITS	Notes
Maximum Supply Voltage	VDDA	Core Supply Voltage			4.6	V	1,7
Maximum Supply Voltage	VDD_IO	Low-Voltage Differential I/O	0.99		3.8	V	1,7
Maximum Input Voltage	V _{IH}	3.3V LVCMOS Inputs			4.6	V	1,7,8
Minimum Input Voltage	V _{IL}	Any Input	V _{SS} - 0.5			V	1,7
Ambient Operating Temp	T _{amb} IND	Industrial Range	-40		85	°C	1
Storage Temperature	T _s	-	-65		150	°C	1,7
Input ESD protection	ESD prot	Human Body Model	2000			V	1,7

Electrical Characteristics—Input/Supply/Common Output Parameters

PARAMETER	SYMBOL	CONDITIONS	MIN	TYP	MAX	UNITS	Notes
Supply Voltage	VDDA	Supply Voltage	3.000	3.3	3.600	V	1
Supply Voltage	VDD _{xx} _IO	Low-Voltage Differential I/O Supply	0.99	1.05-3.3	3.600	V	1
Input High Voltage	V _{IHSE}	Single-ended inputs	2		V _{DD} + 0.3	V	1
Input Low Voltage	V _{ILSE}	Single-ended inputs	V _{SS} - 0.3		0.8	V	1
Differential Input High Voltage	V _{IHDIF}	Differential inputs (single-ended measurement)	600		1.15	V	1
Differential Input Low Voltage	V _{ILDIF}	Differential inputs (single-ended measurement)	V _{SS} - 0.3		300	V	1
Input Slew Rate - DIF_IN	dv/dt	Measured differentially	0.4		8	V/ns	2
Input Leakage Current	I _{IN}	V _{IN} = V _{DD} , V _{IN} = GND	-5		5	uA	1
Operating Supply Current	I _{DD_3.3V}	VDDA supply current		15	20	mA	1
	I _{DD_IO_133M}	VDD_IO supply @ fOP = 133MHz		12	20	mA	1
Power Down Current (All OE# pins High)	I _{DD_SB_3.3V}	VDDA supply current, Input stopped, OE# pins all high		500	750	uA	1
	I _{DD_SBio}	VDD_IO supply, Input stopped, OE# pins all high		100	150	uA	1
Input Frequency	F _i	V _{DD} = 3.3 V	15		167	MHz	2
Pin Inductance	L _{pin}				7	nH	1
Input Capacitance	C _{IN}	Logic Inputs	1.5		5	pF	1
	C _{OUT}	Output pin capacitance			6	pF	1
OE# latency (at least one OE# is low)	T _{OE#LAT}	Number of clocks to enable or disable output from assertion/deassertion of OE#	1	2	3	periods	1
Clock stabilization time (from all OE# high to first OE# low).	T _{STAB}	Delay from assertion of first OE# to first clock out (assumes input clock running and device in power down state))			150	ns	1
Tdrive_OE#	T _{DROE#}	Output enable after OE# de-assertion			10	ns	1
Tfall_OE#	T _{FALL}	Fall/rise time of OE# inputs			5	ns	1
Trise_OE#	T _{RISE}				5	ns	1

AC Electrical Characteristics–DIF Low Power Differential Outputs

PARAMETER	SYMBOL	CONDITIONS	MIN	TYP	MAX	UNITS	NOTES
Rising/Falling Edge Slew Rate	t_{SLR}	Differential Measurement	1.5	2.2	4	V/ns	1,2
Slew Rate Variation	t_{SLVAR}	Single-ended Measurement		13	20	%	1
Maximum Output Voltage	V_{HIGH}	Includes overshoot		783	1150	mV	1
Minimum Output Voltage	V_{LOW}	Includes undershoot	-300	-22		mV	1
Differential Voltage Swing	V_{SWING}	Differential Measurement	1200			mV	1
Crossing Point Voltage	V_{XABS}	Single-ended Measurement	250	336	550	mV	1,3,4
Crossing Point Variation	$V_{XABSVAR}$	Single-ended Measurement		14	140	mV	1,3,5
Duty Cycle Distortion	$D_{CYCDISO}$	Differential Measurement, $f_{IN} \leq 133.33\text{MHz}$		1.6	3	%	1,6
Additive Cycle-to-Cycle Jitter	$DIFJ_{C2CADD}$	Differential Measurement, Additive		2.1	7	ps	1
DIF[3:0] Skew	DIF_{SKEW}	Differential Measurement		19	50	ps	1, 11
Propagation Delay	t_{PD}	Input to output Delay	2.5	3.3	3.8	ns	1
Additive Phase Jitter - PCIe Gen1	$t_{phase_addPCIG1}$	1.5MHz < 22MHz		1.6	6	ps Pk-Pk	1,9
Additive Phase Jitter - PCIe Gen2 High Band	$t_{phase_addPCIG2HI}$	High Band is 1.5MHz to Nyquist (50MHz)		0.1	0.3	ps rms	1,9
Additive Phase Jitter - PCIe Gen2 Low Band	$t_{phase_addPCIG2LO}$	Low Band is 10KHz to 1.5MHz		0.5	0.8	ps rms	1,9
Additive Phase Jitter - PCIe Gen3	$t_{phase_addPCIG3}$	2MHz - 4MHz, 2MHz - 5MHz		0.19	0.3	ps rms	1,9
Additive Phase Jitter 161.1328125MHz = 10.3125G/64	$t_{phase_add10G/64}$	12KHz to 100MHz		60	100	fs rms	1,10

Notes on Electrical Characteristics (all measurements use $R_S=33\text{ohms}/C_L=2\text{pF}$ test load):

¹ Guaranteed by design and characterization, not 100% tested in production.

² Slew rate measured through V_{swing} centered around differential zero

³ V_{xabs} is defined as the voltage where $CLK = CLK\#$

⁴ Only applies to the differential rising edge (CLK rising and CLK# falling)

⁵ Defined as the total variation of all crossing voltages of CLK rising and CLK# falling. Matching applies to rising edge rate of CLK and falling edge of CLK#. It is measured using a +/-75mV window centered on the average cross point where CLK meets CLK#.

⁶ This figure refers to the maximum distortion of the input wave form.

⁷ Operation under these conditions is neither implied, nor guaranteed.

⁸ Maximum input voltage is not to exceed maximum VDD

⁹ The 6V31021 has no PLL, so the part itself contributes very little jitter to the input clock. But this also means that the 9DBL411 cannot 'de-jitter' a noisy input clock. Values calculated per PCI SIG and per Intel Clock Jitter tool version 1.6.6. For PCIe RMS figures, additive jitter is calculated by solving the following equation: Additive jitter = $\text{SQRT}[(\text{total jitter})^2 - (\text{input jitter})^2]$

¹⁰ Calculated from Agilent E5052A phase noise machine.

¹¹ Mean value not including cycle-to-cycle jitter

Marking Diagram

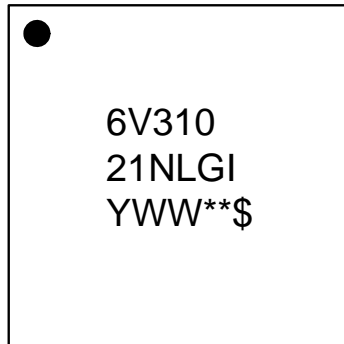

Notes:

1. '**' is the lot sequence.
2. '\$' is the mark code.
3. 'YWW' is the year and week that the part was assembled.
4. 'G' denotes RoHS compliant package.
5. 'I' denotes industrial temperature range.
6. Bottom marking: country of origin if not USA.

Revision History

Rev.	Originator	Issue Date	Description	Page #
0.1	RDW	10/18/2011	Initial Release	
A	RDW	12/12/2011	1. Updated General Description and Key Specifications 2. Added Mark Spec 3. Moved to Final	1, 6

Innovate with IDT and accelerate your future networks. Contact:

www.IDT.com

For Sales

800-345-7015
408-284-8200
Fax: 408-284-2775

For Tech Support

www.idt.com/go/clockhelp
pcclockhelp@idt.com

Corporate Headquarters

Integrated Device Technology, Inc.
www.idt.com





Стандарт Электрон Связь

Мы молодая и активно развивающаяся компания в области поставок электронных компонентов. Мы поставляем электронные компоненты отечественного и импортного производства напрямую от производителей и с крупнейших складов мира.

Благодаря сотрудничеству с мировыми поставщиками мы осуществляем комплексные и плановые поставки широчайшего спектра электронных компонентов.

Собственная эффективная логистика и склад в обеспечивает надежную поставку продукции в точно указанные сроки по всей России.

Мы осуществляем техническую поддержку нашим клиентам и предпродажную проверку качества продукции. На все поставляемые продукты мы предоставляем гарантию .

Осуществляем поставки продукции под контролем ВП МО РФ на предприятия военно-промышленного комплекса России , а также работаем в рамках 275 ФЗ с открытием отдельных счетов в уполномоченном банке. Система менеджмента качества компании соответствует требованиям ГОСТ ISO 9001.

Минимальные сроки поставки, гибкие цены, неограниченный ассортимент и индивидуальный подход к клиентам являются основой для выстраивания долгосрочного и эффективного сотрудничества с предприятиями радиоэлектронной промышленности, предприятиями ВПК и научно-исследовательскими институтами России.

С нами вы становитесь еще успешнее!

Наши контакты:

Телефон: +7 812 627 14 35

Электронная почта: sales@st-electron.ru

Адрес: 198099, Санкт-Петербург,
Промышленная ул, дом № 19, литера Н,
помещение 100-Н Офис 331