

EDM1-CF-iMX6



EDM Type 1 Compact Form Factor Freescale i.MX6 System on Module



ARM Cortex-A9 Freescale i.MX6 scalable single/dual/quad core EDM type 1 compact System-on-Module

Communication by gigabit LAN, WiFi 802.11 b/g/n and Bluetooth v.4.0

Targeting multimedia applications with LVDS, TTL, HDMI, S/PDIF, I²S, MIPI camera and display.

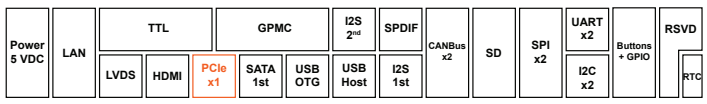

Core System

Signalling CPU
EDM Type 1 compliant Freescale i.MX6Quad @1.0GHz
Freescale i.MX6Dual @1.0 GHz
Freescale i.MX6DualLite @1.0 GHz
Freescale i.MX6Solo @1.0 GHz

System Memory Storage
up to 2GB DDR3
eMMC / iNAND
or optional NAND Flash

Debug Interface
JTAG Interface
FPC Connector
MIPI interface camera
MIPI interface DSI display

Connectivity

Network
Atheros AR8031 Gigabit LAN
Wireless LAN
Broadcom BCM4330
802.11 b/g/n @ 2.4 Ghz
Bluetooth
Bluetooth v. 4.0

Audio

Interface
I²S (2 channel), S/PDIF
Audio Codec
on EDM Carrier Board

Video

	Solo / DualLite	Dual / Quad
GPU 3D	Vivante GC880 35Mtri/s 266Mpxl/s Open GL ES 2.0	Vivante GC2000 200Mtri/s 1000Mpxl/s, OpenGL ES 2.0 & Haulti, CL EP
GPU 2D (Vector Graphics)	emulated on GPU 3D	Vivante GC355 300Mpxl/s, OpenVG 1.1
GPU 2D (Composition)	Vivante GC320 600Mpxl/s, BLIT	Vivante GC320 600Mpxl/s, BLIT
Video Decode	1080p30 + D1	1080p60 H.264
Video Encode	1080p30 H.264 BP/ Dual 720p	1080p30 H.264 BP/ Dual 720p

I/O

Storage
1x SATA 2.0 (Dual / Quad only)
1x SDIO/ MMC
Expansion
1x PCIe 2.0
Display
HDMI v1.4
1 channel LVDS 18/24 bit
24 bit RGB TTL

USB
USB Host 2.0
USB OTG 2.0

CAN Bus
2x Flex CAN
version 2.0B compliant

Serial Port
2x UART

Other
SPI, I²C, GPIO, Local Bus

Power Specifications

Input Power 5 VDC

Operating Systems

Standard Support
Linux
Android

Extended Support
Commercial Linux
Windows Embedded Compact 7
Real Time OS



Mechanical and Environmental

Temperature
Commercial: 0° to 60° C
Extended: -20° to 70° C
* Industrial: -40° to 85° C
(* = no wifi, no eMMC)
10-90%

Humidity
Module Connector
Form Factor
Dimensions
314 pins MXM3
EDM Compact Form Factor
82 x 60 mm
(3 1/8 x 2 3/8 inch)
>100,000 hours

MTBF
Weight
Shock
Vibration
20 grams
50G / 25ms
20G / 0-600 Hz

Dimensions

units in mm

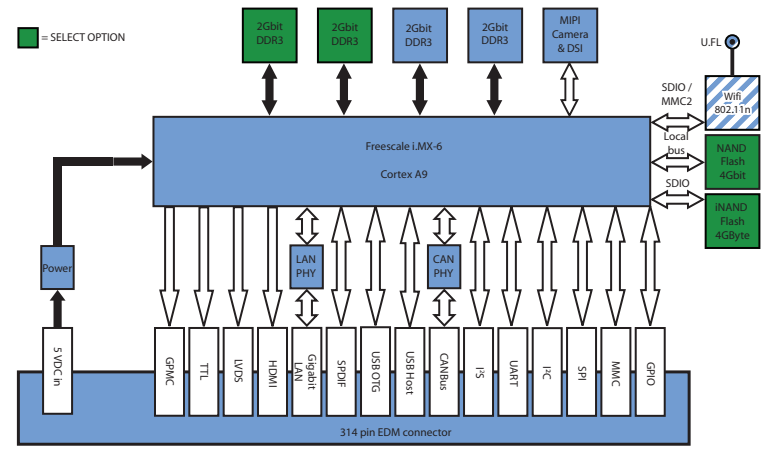
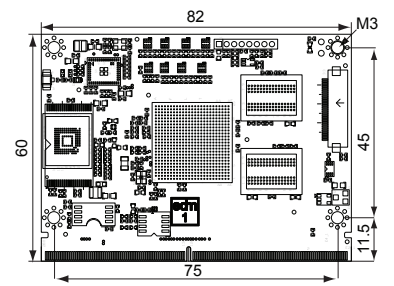

Ordering Information

EDM1-CF-iMX6Q10-BW	Freescale i.MX6 Quad core EDM Compact Type 1 with WiFi and Bluetooth
EDM1-CF-iMX6Q10	Freescale i.MX6 Quad core EDM Compact Type 1
EDM1-CF-iMX6D10-BW	Freescale i.MX6 Dual core EDM Compact Type 1 with WiFi and Bluetooth
EDM1-CF-iMX6D10	Freescale i.MX6 Dual core EDM Compact Type 1
EDM1-CF-iMX6U10-BW	Freescale i.MX6 DualLite core EDM Compact Type 1 with WiFi and Bluetooth
EDM1-CF-iMX6U10	Freescale i.MX6 DualLite core EDM Compact Type 1
EDM1-CF-iMX6S10-BW	Freescale i.MX6 Single core EDM Compact Type 1 with WiFi and Bluetooth
EDM1-CF-iMX6S10	Freescale i.MX6 Single core EDM Compact Type 1

Optional Accessories

EDM-C-Bracket	EDM compact Carrier Board mount bracket
HSP-EDM-C-10W	EDM passive heatsink
HS-EDM-CF-iMX6	EDM-CF-i.MX6 compatible heatspreader

Feel free to contact us for custom tailored Carrier Board request for your projects.



Start Kits

EDM1-CF-iMX6S10-START EDM1-CF-iMX6U10-START EDM1-CF-iMX6D10-START	EDM Compact Type 1 Freescale i.MX6 Solo 1Ghz + 512MB RAM + 4GB iNAND + Gigabit LAN + 2 CAN (EDM1-CF-iMX6S10-R512-Ni4G-L-2C) EDM Compact Type 1 Freescale i.MX6 Duallite 1Ghz + 1GB RAM + 4GB iNAND + Gigabit LAN + 2 CAN (EDM1-CF-iMX6U10-R1GB-Ni4G-L-2C) EDM Compact Type 1 Freescale i.MX6 Dual 1Ghz + 1GB RAM + 4GB iNAND + Gigabit LAN + 2 CAN + SATA & EDM Compact passive heatsink (EDM1-CF-iMX6D10-R1GB-Ni4G-L-S-2C + EDM-HS-CP12-20-05-01)
EDM1-CF-iMX6Q10-START	EDM Compact Type 1 Freescale i.MX6 Quad 1Ghz + 2GB RAM + 4GB iNAND + Gigabit LAN + 2 CAN + SATA & EDM Compact passive heatsink (EDM1-CF-iMX6Q10-R2GB-Ni4G-L-S-2C + EDM-HS-CP12-20-05-01)
EDM1-CF-iMX6S10-BW-START	EDM Compact Type 1 Freescale i.MX6 Solo 1Ghz + 512MB RAM + 4GB iNAND + Gigabit LAN + 2 CAN + 802.11bgn + Bluetooth 4.0 & EDM antenna kit (EDM1-CF-iMX6S10-R512-Ni4G-BW-L-2C + EDM-ANT-P150-A138-045D-2450-BK)
EDM1-CF-iMX6U10-BW-START	EDM Compact Type 1 Freescale i.MX6 Duallite 1Ghz + 1GB RAM + 4GB iNAND + Gigabit LAN + 2 CAN + 802.11bgn + Bluetooth 4.0 & EDM antenna kit (EDM1-CF-iMX6U10-R1GB-Ni4G-BW-L-2C + EDM-ANT-P150-A138-045D-2450-BK)
EDM1-CF-iMX6D10-BW-START	EDM Compact Type 1 Freescale i.MX6 Dual 1Ghz + 1GB RAM + 4GB iNAND + Gigabit LAN + 2 CAN + SATA + 802.11bgn + Bluetooth 4.0 & EDM antenna kit & EDM Compact passive heatsink (EDM1-CF-iMX6D10-R1GB-Ni4G-BW-L-S-2C + EDM-ANT-P150-A138-045D-2450-BK + EDM-HS-CP12-20-05-01)
EDM1-CF-iMX6Q10-BW-START	EDM Compact Type 1 Freescale i.MX6 Quad 1Ghz + 2GB RAM + 4GB iNAND + Gigabit LAN + 2 CAN + SATA + 802.11bgn + Bluetooth 4.0 & EDM antenna kit & EDM Compact passive heatsink (EDM1-CF-iMX6Q10-R2GB-Ni4G-BW-L-S-2C + EDM-ANT-P150-A138-045D-2450-BK + EDM-HS-CP12-20-05-01)

Standard Partnumbers

EDM1-CF-iMX6S10-R512-Ni4G-L-2C EDM1-CF-iMX6U10-R1GB-Ni4G-L-2C EDM1-CF-iMX6D10-R1GB-Ni4G-L-S-2C EDM1-CF-iMX6Q10-R2GB-Ni4G-L-S-2C	EDM Compact Type 1 Freescale i.MX6 Solo 1Ghz + 512MB RAM + 4GB iNAND + Gigabit LAN + 2 CAN EDM Compact Type 1 Freescale i.MX6 Duallite 1Ghz + 1GB RAM + 4GB iNAND + Gigabit LAN + 2 CAN EDM Compact Type 1 Freescale i.MX6 Dual 1Ghz + 1GB RAM + 4GB iNAND + Gigabit LAN + 2 CAN + SATA EDM Compact Type 1 Freescale i.MX6 Quad 1Ghz + 2GB RAM + 4GB iNAND + Gigabit LAN + 2 CAN + SATA
EDM1-CF-iMX6S10-R512-Ni4G-BW-L-2C EDM1-CF-iMX6U10-R1GB-Ni4G-BW-L-2C EDM1-CF-iMX6D10-R1GB-Ni4G-BW-L-S-2C EDM1-CF-iMX6Q10-R2GB-Ni4G-BW-L-S-2C	EDM Compact Type 1 Freescale i.MX6 Solo 1Ghz + 512MB RAM + 4GB iNAND + Gigabit LAN + 2 CAN + 802.11bgn + Bluetooth 4.0 EDM Compact Type 1 Freescale i.MX6 Duallite 1Ghz + 1GB RAM + 4GB iNAND + Gigabit LAN + 2 CAN + 802.11bgn + Bluetooth 4.0 EDM Compact Type 1 Freescale i.MX6 Dual 1Ghz + 1GB RAM + 4GB iNAND + Gigabit LAN + 2 CAN + SATA + 802.11bgn + Bluetooth 4.0 EDM Compact Type 1 Freescale i.MX6 Quad 1Ghz + 2GB RAM + 4GB iNAND + Gigabit LAN + 2 CAN + SATA + 802.11bgn + Bluetooth 4.0

Optional Accessories

EDM-ANT-P150-A138-045D-2450-BK EDM-HS-CP12-20-05-01 EDMCONNECTORKIT	EDM antenna kit containing U.FL to SMA patch cable + 4.5 dB, 2.4/5 GHz, black color antenna. EDM Compact 12 mm passive heatsink + 20*20 mm thermopad with 0.5 mm thickness for Lidded Freescale CPUs + mylar. 10 EDM AS0B821-S78B-7H connectors + 40 standoff's + 40 screws.
---	--

How to create a Custom Partnumber (MOQ's apply)

EDM-CF1-iMX6Q10-R1GB-Ni4G-BW-L-S-2C-TE-xxxx

EDM	Embedded Design Module
EDM Type	Pin definition of EDM Type 1 or Type 2
Formfactor of Module	C = Compact; S = Standard; X = Extended
Chipvendor	F = Freescale
CPU type	for example : i.MX6
CPU cores	S = Single core; U = DualLite; D = Dualcore; Q = Quadcore
CPU speed	10 = 1GHz; 08 = 800MHz
Memory	R512 = 512MB; R1GB = 1GB; R2GB = 2GB
Storage	Ni4G = iNAND 4GB; N512 = 512 NAND Flash (iNAND is only possible in Commercial and Extended temperature. For Industrial Temperature only NAND Flash is possible.
Wireless LAN	None = no wireless communication; W = WiFi; BW = Bluetooth + WiFi (only available in commercial and extended temperature)
Network LAN	None = no Ethernet; L = 1000Gbps Ethernet LAN
SATA	None = no SATA; S = SATA (only on i.MX6 Dual or i.MX6 Quad)
CANbus	None = no CANbus; 1C = 1 CANbus; 2C = 2 CANbus
Temperature	None = Commercial Temp (0~60C); TE = Extended Temp (-20~70C); TI = Industrial Temp (-40~85C); TEC = Extended Temperature Certified; TIC = Industrial Temperature Certified
Customer ID code	xxxx = special order code for custom softwrae loading or BOM option



Стандарт Электрон Связь

Мы молодая и активно развивающаяся компания в области поставок электронных компонентов. Мы поставляем электронные компоненты отечественного и импортного производства напрямую от производителей и с крупнейших складов мира.

Благодаря сотрудничеству с мировыми поставщиками мы осуществляем комплексные и плановые поставки широчайшего спектра электронных компонентов.

Собственная эффективная логистика и склад в обеспечивает надежную поставку продукции в точно указанные сроки по всей России.

Мы осуществляем техническую поддержку нашим клиентам и предпродажную проверку качества продукции. На все поставляемые продукты мы предоставляем гарантию .

Осуществляем поставки продукции под контролем ВП МО РФ на предприятия военно-промышленного комплекса России , а также работаем в рамках 275 ФЗ с открытием отдельных счетов в уполномоченном банке. Система менеджмента качества компании соответствует требованиям ГОСТ ISO 9001.

Минимальные сроки поставки, гибкие цены, неограниченный ассортимент и индивидуальный подход к клиентам являются основой для выстраивания долгосрочного и эффективного сотрудничества с предприятиями радиоэлектронной промышленности, предприятиями ВПК и научно-исследовательскими институтами России.

С нами вы становитесь еще успешнее!

Наши контакты:

Телефон: +7 812 627 14 35

Электронная почта: sales@st-electron.ru

Адрес: 198099, Санкт-Петербург,
Промышленная ул, дом № 19, литера Н,
помещение 100-Н Офис 331