

VI Chip® Remote Sense PRM Evaluation Board

Written by: Ankur Patel
Applications Engineer
June 2014



| | |
|---|-------------|
| Contents | Page |
| <i>Introduction</i> | 1 |
| <i>Considerations for Remote Sense only PRM</i> | 3 |
| <i>Contents</i> | 3 |
| <i>Features</i> | 4 |
| <i>Board Description</i> | 5 |
| <i>General Components</i> | 6 |
| <i>Test Points</i> | 8 |
| <i>Sockets</i> | 9 |
| <i>Schematic</i> | 10 |
| <i>Assembly Drawings</i> | 12 |
| <i>Bill of Materials</i> | 14 |
| <i>VTM Evaluation Boards</i> | 17 |
| <i>Recommended Test Equipment</i> | 18 |
| <i>Board Operating Modes</i> | 19 |
| <i>Common Features</i> | 20 |
| <i>Remote Sense</i> | 21 |
| <i>Operating Mode: PRM</i> | 21 |
| <i>Remote Sense</i> | 22 |
| <i>Operating Mode: PRM & VTM</i> | 22 |
| <i>Trim and Soft Start Adjustment</i> | 23 |
| <i>Current Limit Adjustment</i> | 24 |
| <i>Slave Operating Mode</i> | 24 |
| <i>Paralleling</i> | 25 |
| <i>Conclusion</i> | 25 |

Introduction

The Remote Sense PRM evaluation boards described in this document are designed to use with the PRM family of PRM regulators and demonstrate the benefits of the Factorized Power Architecture™. These evaluation boards are not designed for installation in end user equipment. The system demonstrates the use of a PRM (the pre-regulator module) and a VTM (the current multiplier or the voltage transformation module) for general laboratory evaluation only.

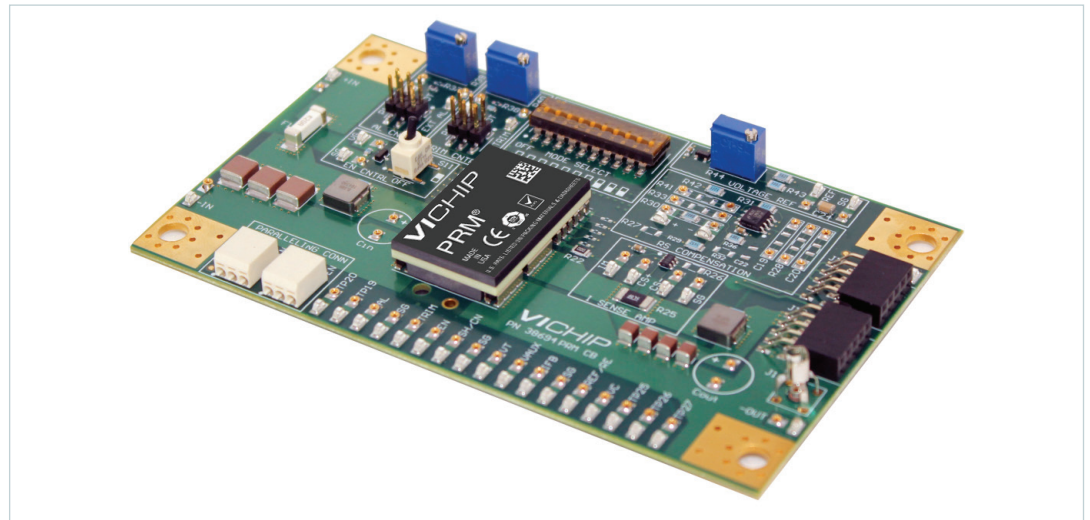

IMPORTANT NOTICE:

Be sure to read this design guide manual thoroughly before using this product. Pay attention to all cautions and warnings.

This user guide is not comprehensive and is not substitute for common sense and good practice. For example:

- When testing electronic product always use approved safety glasses.
- Provide a strain relief for wires and place the system on the bench in such a way as to prevent accidental displacement from bench top.
- Remove the power and use caution when connecting and disconnecting test probes and interface lines to avoid unintentional short circuits and contact with hot surfaces.
- Never use a jumper in place of the fuse. Replace the fuse only with its equivalent type and rating.
- Never attempt to disconnect the evaluation board from a VTM® evaluation board while power is applied. This system is not designed to demonstrate the hot plug capability.

The Remote Sense PRM evaluation board can be used to demonstrate a stand-alone buck-boost regulator or in conjunction with a VTM evaluation board to enable evaluation of a Factorized Power Architecture™ (FPA) system. There are many combinations possible using PRM and VTM evaluation boards, but the focus in this user guide is using one PRM evaluation board and one VTM evaluation board, with a brief overview of how to parallel boards.

In Remote Sense Operation the internal regulation circuitry is disabled and an external control loop and current sensor maintain regulation. This affords flexibility in the design of both voltage and current compensation loops to optimize performance in the end application. The Remote Sense PRM module evaluation board can be used to configure the PRM in local sense mode or in non-isolated remote sense mode depending on the application.

Table 1.
Evaluation board numbers
and their ratings

| Remote Sense PRM Part Number (PS10) | Evaluation Board Number | Description | Input Voltage (V) | Output Voltage (V) | Output Power (W) |
|-------------------------------------|-------------------------|---|-------------------|--------------------|------------------|
| PRM48BF480T600A00 | PRD48BF480T600A00 | Full-Chip Remote Sense PRM Evaluation Board | 38 V to 55 V | 5 V to 55 V | 600 W |
| PRM48BF480T400B00 | PRD48BF480T400B00 | Full-Chip Remote Sense PRM Evaluation Board | 38 V to 55 V | 5 V to 55 V | 400 W |
| PRM48BH480T200B00 | PRD48BH480T200B00 | Half-Chip Remote Sense PRM Evaluation Board | 38 V to 55 V | 5 V to 55 V | 200 W |

Refer to the specific PRM data sheet for detail ratings of the device. It is important to remain within the device limits when testing.

These boards make it convenient to evaluate the performance of Vicor's PRM products. All evaluation boards include sockets to allow easy "plug and play" insertion and removal of through-hole components and wires while providing kelvin voltage measurements test points of all pins of the PRM. Evaluation boards are designed to simplify testing of the product by providing test points and sockets for easy connection to standard test-equipment, lugs for input/output connections, connectors to allow easy insertion and removal of the PRM evaluation board and VTM evaluation board.

Please note that Not all evaluation board part numbers have been listed here. Full chip and half chip PRMs of different output power level may be using common full chip and half chip evaluation boards. Design specific components have been arranged in table 6 based on PRM output power level. It is recommended that the user should, first, find out which PRM part number is mounted on evaluation board. Second, please refer to appropriate data sheet for pin functions of PRM and modes of operation. Third, follow the appropriate section of the user guide to use the PRM evaluation board in specific modes of operation.

Considerations for Remote Sense only PRM

This board is designed to accommodate different types of PRMs. Therefore, certain circuitry on the board is not populated and there are additional considerations for using Remote Sense only PRMs.

The Remote Sense PRM Evaluation Board does not operate in default switch S10 setting which has all switches in the OFF position. Switch at position 1 must remain in the OFF position. Putting switch at position 1 in the ON position could short the TM pin which would cause damage. Switch at position 6 must remain in the OFF position as well. Please see appropriate section for switch setting and mode of operation.

The silkscreen may not match the pin names for Remote Sense PRM. Following table maps pin names of the Remote Sense PRM to silkscreen and standard PRM.

Table 2.

| Remote Sense PRM | PRM | Silkscreen on the Board |
|------------------|--------------------|-------------------------|
| PR | SHARE/CONTROL NODE | SH/CN |
| PC | ENABLE | EN |
| TM | TRIM | TRIM |
| NC | NC | TP20 |
| NC | NC | TP19 |
| NC | AL | AL |
| VC | VC | VC |
| RE | REF/REF_EN | RE |
| SG | SGND | SG |
| IF | IFB | IFB |
| VS | VAUX | VAUX |
| NC | VT | VT |

Contents

All Remote Sense PRM evaluation boards arrive with the following contents.
(The user guide can be downloaded from the www.vicorpower.com)

- 1 x Remote Sense PRM evaluation board
- 1 x VI Chip push pin heat sink
- 2 x VI Chip push pins for heat sink installation
- 2 x VI Chip push pin heat sink grounding clips
- 1 x hardware kit
- 1 x through-hole aluminum-electrolytic input capacitor (C_{IN})
- 1 x through hole resistor for default compensation (R28)
- 1 x through hole capacitor for default compensation (C20)
- 2 x jumpers

Features

1. Input and output lugs for source and load connections.
2. Input fuse (appropriately rated).
3. Input filtering and sockets to place through-hole input aluminum-electrolytic capacitor for source decoupling.
4. Output filtering and sockets to place through-hole output aluminum-electrolytic capacitor.
5. Switch for enabling and disabling the PRM through the ENABLE pin.
6. Open drain MOSFET for enabling and disabling the PRM using external source.
7. Mode selection switch for Remote Sense PRM configurations.
8. Trim control selection. (Not applied)
9. Adaptive Loop control selection. (Not applied)
10. Output current sensing for output current measurement and current feedback in Remote Sense Operation.
11. Sockets and circuits to optimize the external control circuits in Remote Sense Operation.
12. Voltage reference to trim pot for adjusting output voltage set point in Remote Sense Operation.
13. Dual output connectors for transferring the power and signal connections to downstream VTM® evaluation board.
14. Oscilloscope probe jack for making accurate output voltage measurements.
15. Dual paralleling connectors for PC, PR and SG signal connections to other PRM evaluation board.
16. Kelvin voltage test points and sockets for all pins of PRM.
17. Test points for current sensing and AC signal injection (RS mode).
18. Provision for installing the heat sink.

Board Description

The following section provides a detailed description of the evaluation board components, test points and sockets.

Figure 1.
Board description

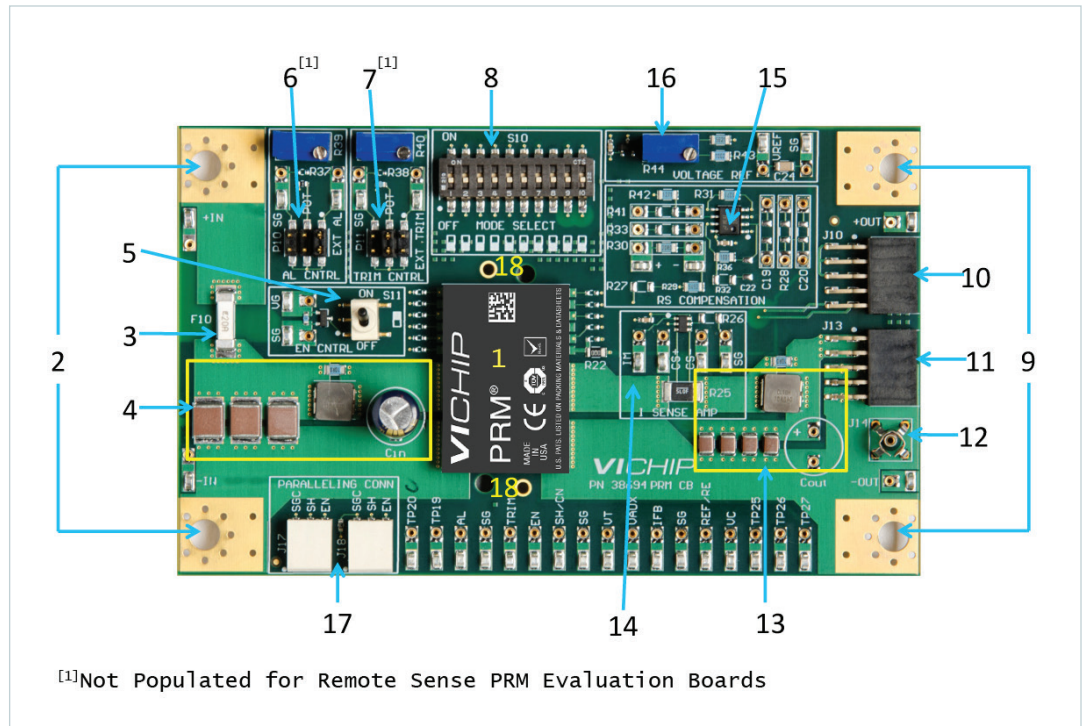
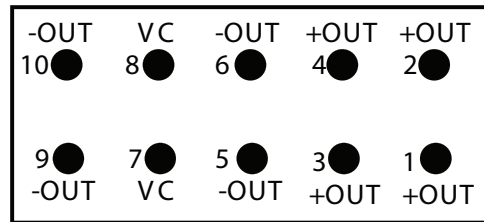
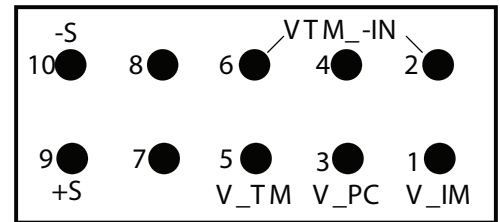

Figure 2.
Power/signal connectors
pinout, front view



J13
Power/signal connector



J10
Signal connector

General Components

1. Remote Sense PRM (PS10)
2. Input lugs: Sized for #10 hardware. Use these for making connection to the input source. This board does not contain reverse polarity protection. Check for proper polarity before applying the power.
3. Input fuse (F10): Appropriately rated.
4. Input filtering: Input capacitor (C_{IN}) and filtering (inductor and ceramic capacitors) allows for stable operation with most input sources. Sockets can be used for easy installation of aluminum-electrolytic input capacitor. It is recommended to place the 22 μ F, 100 V input electrolytic capacitor in the sockets at the input of the PRM®.
5. Enable/Disable switch (S11) and FET switch: When actuator is in top position towards “ON” text on the board, the ENABLE pin will be open and PRM device will be enabled. When actuator is in bottom position towards “OFF” text on the board, the ENABLE pin will be connected to SGND and PRM device will be disabled. When switch S11 is ON, open drain FET can be selected to control the ENABLE pin using external source.
6. Header-jumper for Adaptive Loop control (P10): Provides the option to select and enable Adaptive Loop control.
Note: Not Populated for Remote Sense PRM Evaluation Boards.
7. Header-jumper for trim control (P11): Provides the option to select and enable the trim control.
Note: Not Populated for Remote Sense PRM Evaluation Boards.
8. Operating Mode selection switch (S10): For selecting one of the following operating modes:
 - a. Slave Operation (used in PRM paralleling)
 - b. Remote Sense: Local sensing (single ended)
 - c. Remote Sense: Non-isolated remote sensing (differential)
9. Output lugs: Sized for #10 hardware. Use these lugs to connect the output directly to the load.

General Components (Cont.)

10. Signal connector (J10): Used to transfer VTM® PC, IM, TM, -IN and Output Sense signals between the PRM and VTM boards. TM pin of VTM provides feedback to VT pin of PRM to enable temperature compensation in Adaptive Loop Operation of PRM® and VTM.
11. Power/Signal connector (J13): Used to transfer power (+OUT/-OUT) and VC to downstream VTM board when used.
12. Output oscilloscope probe Jack (J14): Used for making the accurate scope measurements of the output voltage (i.e. ripple). Remove scope grounding lead and insert probe directly into jack ensuring a good connection between the jack and the probe ground barrel. Do not attempt to install while power is applied. May not be compatible with all scope probes.
13. Output capacitor (C_{OUT}) and output filtering (inductor and ceramic capacitors): Helps to minimize the switching ripple of the output voltage. Sockets can be used for easy installation of aluminum-electrolytic output capacitor.
14. High-side current-sense resistor and current-sense IC (R25 and U10): Current-sense shunt monitors the output current and IC provides the feedback to the IFB pin for constant current limit protection in Remote Sense Operation. Gain is programmed using resistor R26. Constant current limit is set at ~10% above the rated output current of the PRM on all boards.
15. Voltage sense and error amplifier: Dual op-amp provides the voltage sensing and error amplifier function. It can be configured for local voltage sensing at the PRM output or a differential amplifier to allow for non-isolated remote sensing at the VTM output or load in Remote Sense Operation. Sockets are provided for compensation components.
16. Voltage reference and output voltage trim pot (R44) for external voltage control loop: Remote Sense Operation trim pot adjusts the output voltage by increasing and decreasing the error amplifier reference voltage (V_{REF}). Turn clockwise to increase the output voltage and counterclockwise to decrease the output voltage. Sockets can be used for easy installation of soft start ceramic capacitor.
17. Dual paralleling wire to board connectors (J17 and J18): Used for transferring signal pins (PC, PR and SG) in parallel operation from one board to other board. Provides simple strip and insert option. Accepts 18-24AWG solid wires. Spring loaded contact will grab solid wire with no need for soldering. Connection requires for parallel regulator operation are grouped together.
18. Push-pin heat sink and grounding clip mounting holes: Use these holes for installing the optional push pin heat sink and grounding clips included with the board. Use of the heat sink with fan is highly recommended for appropriate cooling of the PRM module.

Test Points Description

Each test point has a socket which accepts 0.015 – 0.025 inch diameter leads for easy installation of solid wires and through-hole components. All the test points are brought out to the edge of the board to allow for easy measurement and/or connection to the user's external circuitry. All test points are labeled and routed to the edge of the board. Each test point is accompanied with an adjacent socket for adding a test lead or to facilitate wiring to external circuitry.

Table 3.

Test points description

Note: for RS PRM, silkscreen may not match pin name. See section: Considerations for Remote Sense only PRM

| Reference Designator | Functional Name | Functional Description |
|----------------------|-----------------|--|
| TP30, TP33 | +IN, -IN | Input voltage test points provide kelvin connection to input pins of the PRM®. Use these test points for measuring the input voltage of the PRM to avoid error due to interconnect losses. |
| TP31, TP32 | +OUT, -OUT | Output voltage test points provide kelvin connection to output pins of the PRM. Use these test points for measuring the output voltage of the PRM to avoid error due to interconnect losses. |
| TP34, TP21, TP22 | SG | Signal Ground (SG) test points are the ground reference for all control circuitry and signal pins of the PRM. |
| TP28, TP29 | CS+, CS- | Used to measure the output current of the PRM across shunt resistor R25. |
| TP35, TP36 | IM, SG | Used to measure the output of current sense IC with reference to SG. |
| TP10 | PR | Used to measure the PR signal of the PRM with reference to SG test point. |
| TP11 | NC | No Connect. For internal use only. |
| TP12 | TM | Used to measure the TM signal of the PRM with reference to SG test point. |
| TP13 | VS | Used to measure the VS signal of the PRM with reference to SG test point. |
| TP14 | RE | Used to measure the RE signal of the PRM with reference to SG. |
| TP15 | NC | No Connect. For internal use only. |
| TP16 | PC | Used to measure the PC signal with reference to SG. |
| TP17 | VC | Used to measure the VC signal with reference to SG. |
| TP18 | IF | Used to measure the IF signal of the PRM with external constant current circuit with reference to SG in Remote Sense Operation. |
| TP43, TP44 | VREF | Used to measure the voltage reference signal of the error amplifier with reference to SG in Remote Sense Operation. |
| TP19, TP20 | NC | No connect. For internal use only. |
| TP37, TP38 | | Can be used to inject the isolated signal of network analyzer for bode plot measurement to measure the stability in Remote Sense Operation. |
| TP23, TP24 | VG, SG | Can be used to connect function generator to control the open drain MOSFET in ENABLE control. |
| TP39, TP41 | | Not Applied. |
| TP40, TP42 | | Not Applied. |

Sockets Description

Each socket accepts 0.015 – 0.025 inch diameter leads for easy installation of solid wires and through-hole components for use with external circuit and test equipment.

Table 4.
Sockets description

| Reference Designator | Functional Name | Functional Description |
|----------------------|--------------------------------------|--|
| H57, H58 | Input Capacitor (C _{IN}) | Sockets are used for easy installation of through-hole 100 V rated aluminum-electrolytic capacitor. |
| H32, H33 | Output Capacitor (C _{OUT}) | Sockets are used for easy installation of through-hole 100 V rated aluminum-electrolytic capacitor. Ensure proper polarity with short leads while installing. |
| H49, H53 | | Not Applied. |
| H50, H54 | | Not Applied. |
| H41, H43 | Compensation Capacitor (C20) | Used for easy installation of through-hole compensation capacitor C20 in feedback path of error amplifier. Default through-hole 4700 pf capacitor is added in the box. Used only with Remote Sense Operation. |
| H42, H44 | Compensation Resistor (R28) | Used for easy installation of the through-hole compensation resistor R28 in feedback path of the error amplifier. Default through-hole 20 K resistor is added in the box. Used only with Remote Sense Operation. |
| H39, H40 | Integrator Capacitor (C19) | Used for easy installation of through-hole compensation capacitor C19. |
| H47, H48 | Differential Input Resistor (R33) | Used for easy installation of through-hole resistor R33 for non-isolated differential sensing in Remote Sense Operation. |
| H51, H52 | Differential Input Resistor (R41) | Used for easy installation of through-hole resistor R41 for non-isolated differential sensing in Remote Sense Operation. |
| H55, H56 | Soft-start Capacitor (C24) | Used for easy installation of the through-hole capacitor on top of default 0.1uF to soft-start the PRM output voltage in Remote Sense Operation. |
| H46, H45 | | Used to insert wires to hook up the network analyzer measuring probes to measure stability in Remote Sense Operation. |
| H30, H31 | CS+ CS- | Used to insert test leads to measure the voltage across R25. |

Schematic

Schematic for half-chip and full-chip Remote Sense PRM evaluation board is same.

Figure 3a.
Remoste Sense
PRM evaluation board
schematic

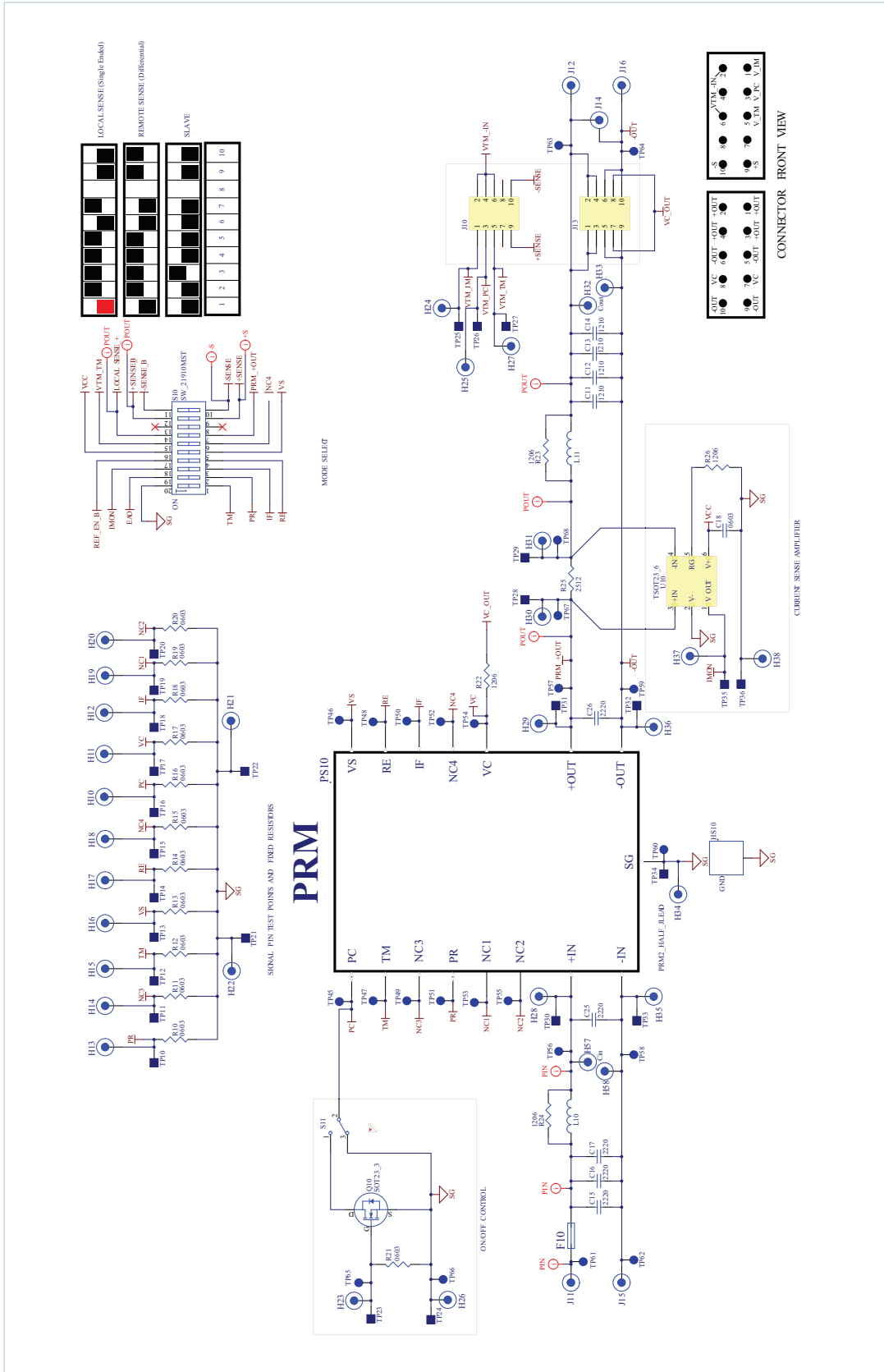

Schematic (Cont.)

Figure 3b.
Remoste Sense
PRM evaluation
board schematic

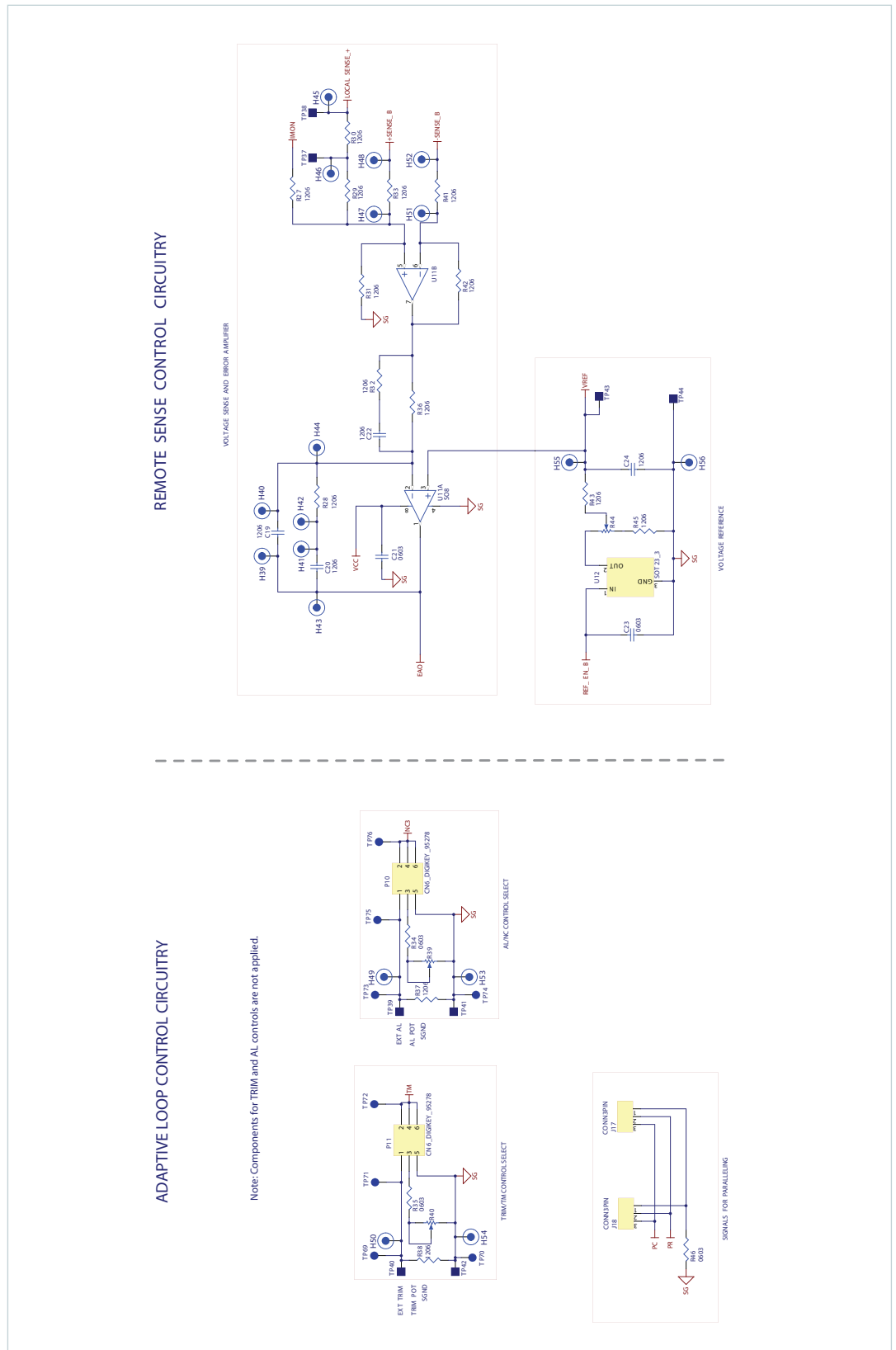

Assembly Drawings

Figure 4a.
Top view: Half-chip
evaluation board
assembly drawing

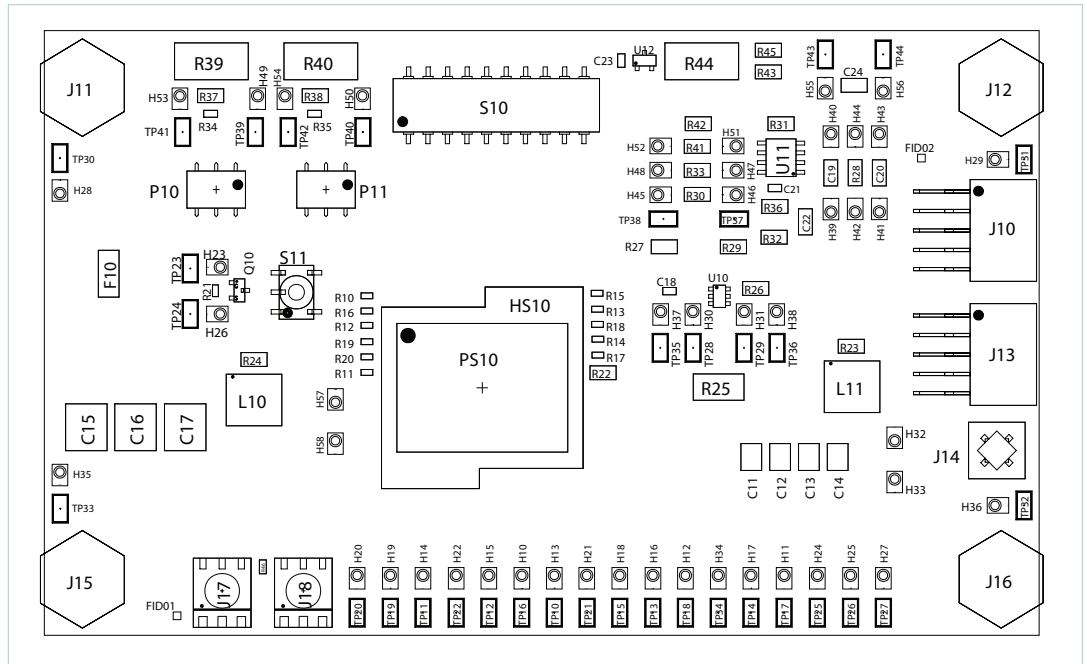
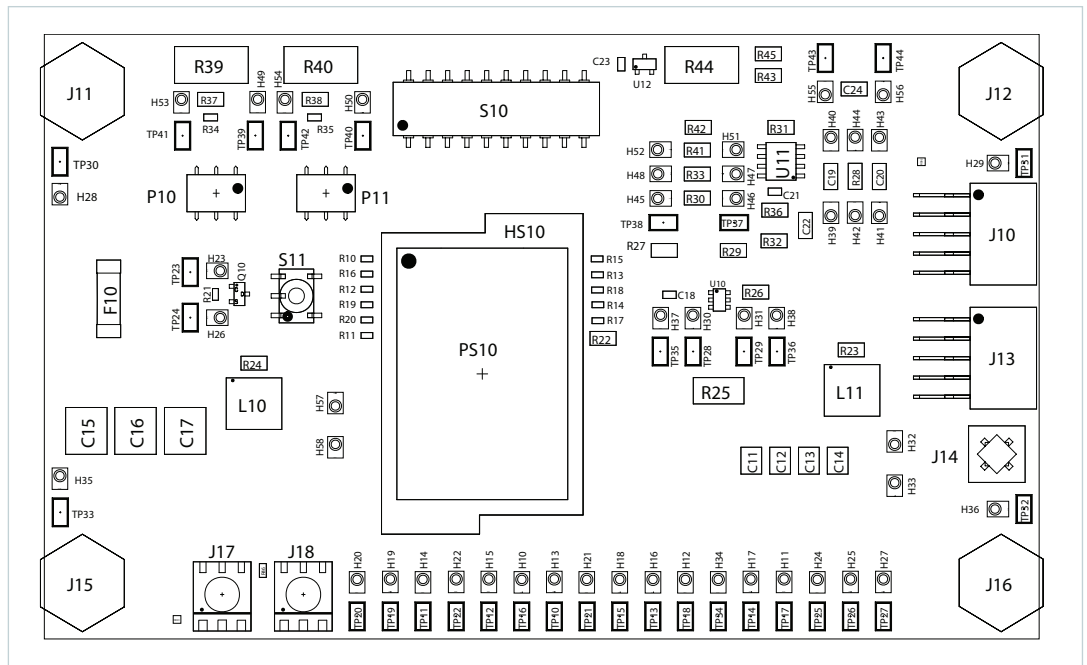
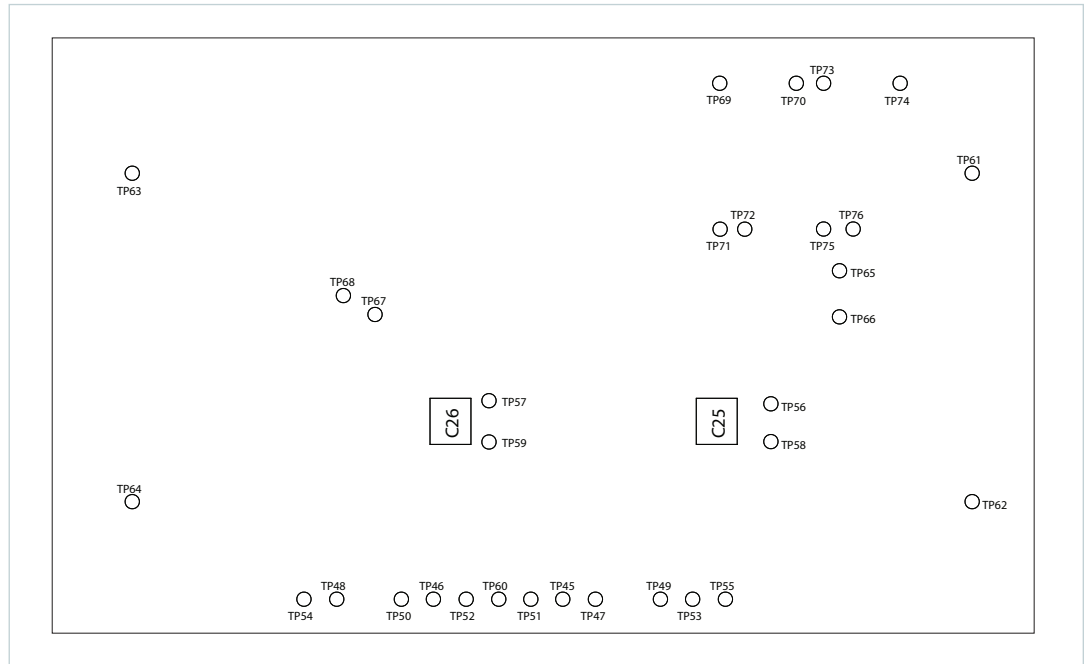

Figure 4b.
Top view: Full-chip
evaluation board
assembly drawing



Assembly Drawings (Cont.)

Figure 4c.
Bottom view: Half-chip/Full-chip
evaluation board
assembly drawing



Bill of Materials

Following table describes the most common components of full chip and half chip Remote Sense PRM evaluation boards.

Table 5.
Common components

| Reference Designator | Description | Manufacturer | Manufacturer Part Number |
|----------------------------------|---|---------------------|--------------------------|
| C11, C12, C13, C14 | CAP X7R 2.2uF 10% 100V 1210 .102 MAX HT | TDK CORP OF AMERICA | C3225X7R2A225KT5LOU |
| C15, C16, C17 | CAP X7R 4.7uF 20% 100V 2220 | TDK | C5750X7R2A475M |
| C18, C21, C23 | CAP X7R .01uF 10% 100V 0603 | MURATA | GRM188R72A103KA01J |
| C20* not applied– use sockets | CAP X7R 4700pF 10% 50V RADIAL | AVX CORP | SR155C472KAR |
| C24 | CAP X7R .10uF 10% 100V 1206 | AVX CORP | 12061C104KATMA |
| CIN | CAP ALEL 22uF 20% 100V RADIAL 8 X 11.5 | PANASONIC | EEU-FC2A220 |
| F10 | Design Specific – see Table 5 | | |
| H10 to H58 | PIN RECPT .015/.025 DIA 0667 SER TH | MILL-MAX MFG CORP | 0667-0-57-15-30-27-10-0 |
| J10, J13 | CONN 10 PINS 2.54MM PITCH DUAL ROW SM HO | GCT | BG225-10-A-N-A |
| J14 | JACK VERTICAL MECH THRU HOLE | TEKTRONIX | 131-5031-00 |
| J17, J18 | CONN 3 POS WIRE TO BOARD SMD | AVX CORP | 478-6170-2-ND |
| JUMPER_HEADER | JUMPER SOCKET XJ8A | OMRON ELECTRONICS | XJ8A-0211 |
| L10, L11 | IND 0.1uH 20% 32.5A 2525 | VISHAY/DALE | IHLP2525CZERR10M01 |
| P10, P11 | Not Applied | | |
| PCB | Design Specific – see Table 5 | | |
| PS10 | Design Specific – see Table 5 | | |
| Q10 | FET 2N7002 SOT-23 | ON SEMICONDUCTOR | 2N7002LT1G |
| R21 | RES 10K OHM 1/10W 1% 0603 | KOA SPEER | RK73H1J1002FTD |
| R22 | RES ZERO OHM JUMPER 2A 1206 | KOA SPEER | RK73Z2BTDD |
| R23, R24 | RES 1 OHM 1/4W 5% 1206 | KOA SPEER | RK73B2BTTE1R0J |
| R25 | Design Specific – see Table 5 | | |

Bill of Materials (Cont.)

Following table describes the most common components of all four versions of PRM® evaluation boards.

Table 5 (Cont.).
Common components

| Reference Designator | Description | Manufacturer | Manufacturer Part Number |
|----------------------------------|---|---------------------------|--------------------------|
| R26 | Design Specific – see Table 5 – Remote Sense Operation – set the constant current limit | | |
| R28* – not applied – use sockets | RES 20K OHM 1/4W 1% AXIAL | KOA SPEER | MF1/4DCT52R2002F |
| R29 | RES 54.9K OHM 1/4W 1% SMD 1206 | KOA SPEER | RK73H2BTTE5492F |
| R30 | RES 20 OHM 1/4W 1% 1206 | KOA SPEER | RK73H2BTDD20R0F |
| R31, R42 | RES 1.27K OHM 1/4W 1 % SMD 1206 | KOA SPEER | RK73H2BTTE1271F |
| R34 | Not Applied | | |
| R35 | Not Applied | | |
| R36 | RES 1K OHM 1/4W 1% 1206 | KOA SPEER | RK73H2BTTE1001F |
| R39, R40 | Not Applied | | |
| R43 | RES 10K OHM 1/4W 1% 1206 | KOA SPEER | RK73H2BTTE1002F |
| R44 | RES TRIM POT 10K OHM 1/2W 10% TH | COPAL ELECTRONIC | CT94EY103 |
| R45 | RES 1K OHM 1/4W 1% SMD 1206 | KOA SPEER | RK73H2BTTE1001F |
| R46 | RES 1 OHM 1/10W 1% 0603 | PANASONIC | ERJ-3RQF1ROV |
| S10 | MECH SMD 10-POS DIP SWITCH | CTS ELECTROCOMPONENTS | 219-10MSTRF |
| S11 | SW TOGGLE SPDT 1 POS SMD | C & K COMPONENTS | GT11MSCBE |
| TP10 to TP44 | TEST POINT, SURFACE MOUNT | KEYSTONE | 5017 |
| U10 | IC HV I SENSE LMP8645HV TSOT-6 | NATIONAL SEMICONDUCTOR | LMP8645HVMKE/NOPB |
| U11 | IC DUAL OPAMP LM6142AIM 8PIN SO | NATIONAL SEMICONDUCTOR | LM6142AIMNOPB |
| U12 | IC VREF 1.25V REF3312 SOT23 3 | TI | REF3312AIDBZT |

Please note that R28 and C20 are through-hole default compensation components required for Remote Sense operation.

Bill of Materials (Cont.)

Following table describes the design specific components of all four versions of PRM® evaluation boards.

Table 6.
Design specific components

| Reference Designator | Description | Manufacturer | Manufacturer Part Number |
|---|-----------------------------------|--------------|--------------------------|
| Evaluation board number: PRD48BF480T400B00 | | | |
| PS10 | REMOTE SENSE PRM FULL CHIP 400W | VICOR | PRM48BF480T400B00 |
| R26 | RES 215K OHM 1/4W 1% 1206 | KOA SPEER | RK73H2BTTE2153F |
| R25 | RES I SENSE 5m OHM 1W 1% 2512 | VISHAY | WSL25125L000FEA |
| F10 | FUSE 20A 125VAC FAST 10.1X3.1 SMD | LITTELFUSE | 0456020.ER |
| PCB | SNGLTD PCB FULL PRM CONFIG CB | VICOR | 39573 |
| Evaluation board number: PRD48BH480T200B00 | | | |
| PS10 | REMOTE SENSE PRM HALF CHIP 200W | VICOR | PRM48BH480T200B00 |
| R26 | RES 215K OHM 1/4W 1% 1206 | KOA SPEER | RK73H2BTTE2153F |
| R25 | RES I SENSE 10m OHM 3W 1% 2512 | BOURNS | CRA2512-FZ-R010ELF |
| F10 | LITTLE FUSE 10 AMP R451010.MRL | LITTELFUSE | 0451010.MRL |
| PCB | SNGLTD PCB HALF PRM CONFIG CB | VICOR | 38693 |
| Evaluation board number: PRD48BF480T600A00 | | | |
| PS10 | REMOTE SENSE PRM FULL CHIP 600W | VICOR | PRM48BF480T600A00 |
| R26 | RES 178K OHM 1/4W 1% 1206 | KOA SPEER | RK73H2BTTE1783F |
| R25 | RES I SENSE 4m OHM 1W 1% 2512 | PANASONIC | ERJM1WSF4M0U |
| F10 | FUSE 25A 125VAC FAST 10.1X3.1 SMD | LITTELFUSE | 0456025.ER |
| PCB | SNGLTD PCB FULL PRM CONFIG CB | VICOR | 39573 |

VTM® Evaluation Boards

The Remote Sense PRM evaluation board is designed to work with all types of VTM® evaluation boards to facilitate testing of virtually any PRM®/VTM combination. The VTM evaluation board contains dual connectors designed to mate with J10 and J13 on PRM evaluation board. The additional signal connector is used to transfer VTM signal pins, as well as S+ and S- signals between boards. The S+ and S- signals are tied to the VTM output using local sense resistors and can be used for implementing non-isolated remote sense as described in a later section. Board also provides the ability to inject an AC signal for measuring the loop response and break the isolation for non-isolated remote sense using PRM and VTM.

Figure 5.
VTM evaluation board

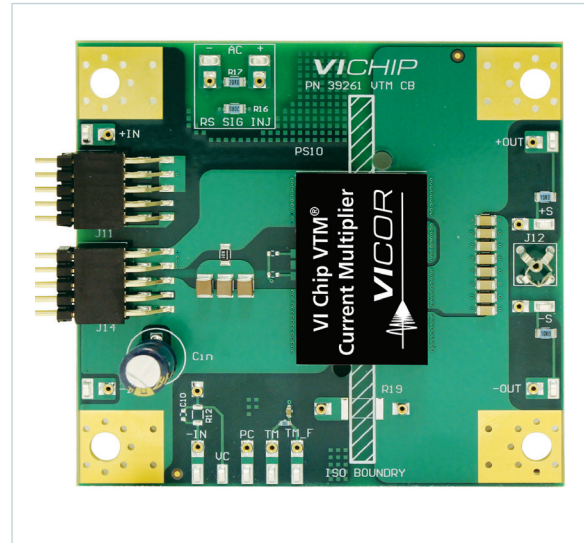

Figure 6.
VTM evaluation board
connector pin out
(front view)

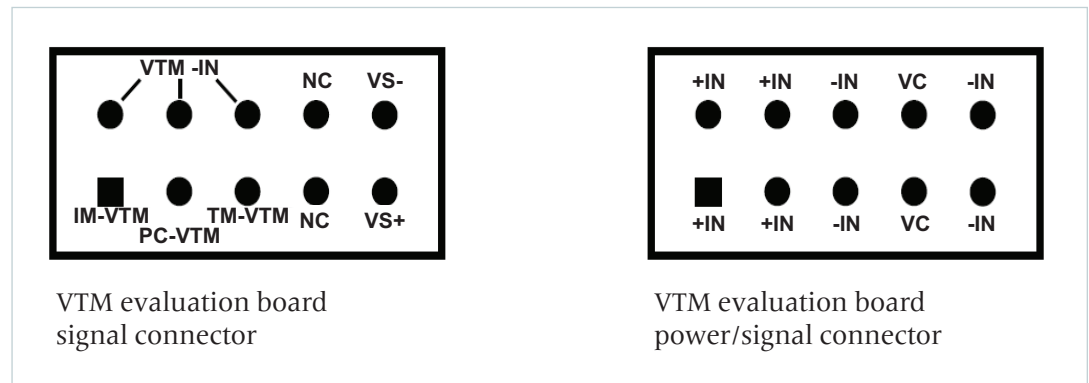
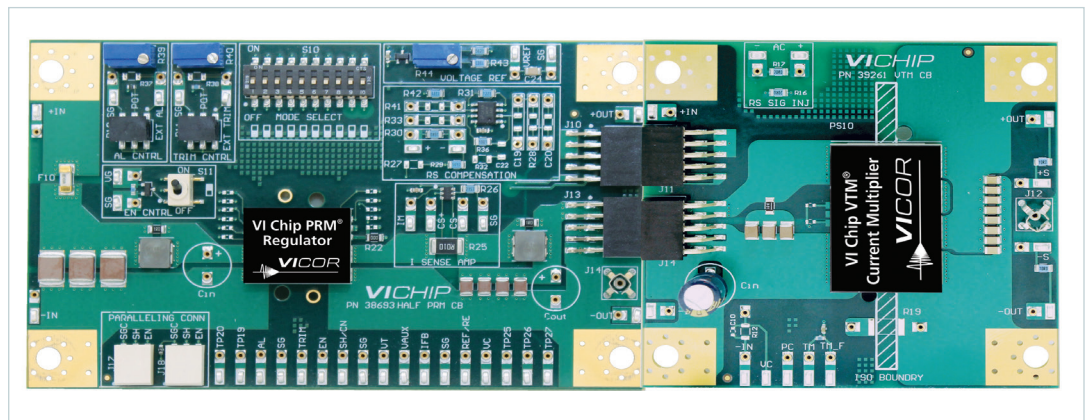

Figure 7.
Remote Sense
PRM evaluation board
connection to
VTM evaluation board



Recommended Test Equipment

The following is a list of recommended test equipment.

1. DC power supply: 0 - 80 V, 600 W minimum
2. Load: Rated appropriately based on output voltage, current and power requirements.
3. Digital multi-meters (DMMs)
4. Oscilloscope + probes
5. Function generator (for external enable/disable)
6. Auxiliary bench voltage supply
7. Network analyzer
8. Interconnect wires, cables and fastening hardware.
9. Calibrated input and output shunts, appropriately rated (for efficiency measurements)
10. Trim pot screwdriver
11. Fan
12. Datasheets of requisite PRM® and VTM® device used.
13. Safety glasses
14. Thin bladed tool for wire extraction from paralleling connectors (AVX part number: 06-9276-7001-01-000)

Push Pin Heat Sink Installation

Each PRM and VTM evaluation board comes with its own heat sink and push pins for installation. Before testing, it is highly recommended that heat sinks be installed in the appropriate location for each board. When installing the push pin heat sink, use caution not to exceed the maximum compressive on the device listed in the data sheet.

Line and Load Connections

- Make sure that input power supply is OFF.
- Connect the input power supply positive lead to the +IN input lug of the evaluation board.
- Connect the input power supply return lead to the -IN input lug of the evaluation board.
- Connect the output lug +OUT to the positive terminal of the electronic load.
- Connect the output lug -OUT to the return terminal of the electronic load.
- Verify proper polarity of the connections.
- Place the input capacitance 22 uF, 100 V.
- Turn the FAN ON.
- Have the latest version of the datasheet.

Board Operating Modes

Remote Sense PRM evaluation board supports different Remote Sense configurations. Therefore, operating mode selection switch S10 is provided on the board for selection of the following operating modes:

- Remote Sense: local sensing (single ended)
- Remote Sense: non-isolated remote sense (differential)
- Slave (for array operation)

Figure 8.
Mode select switch

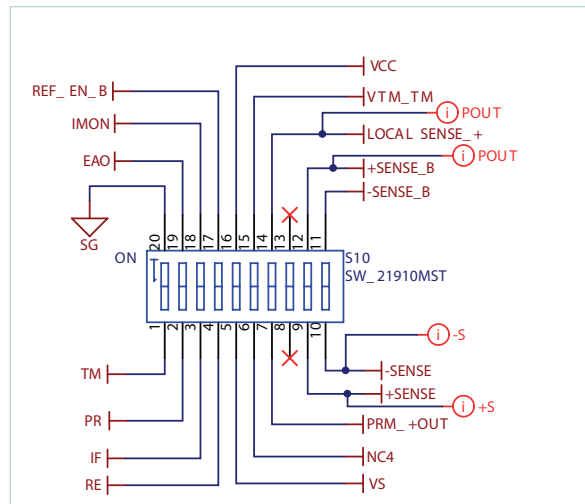

Figure 9.
Switch configuration

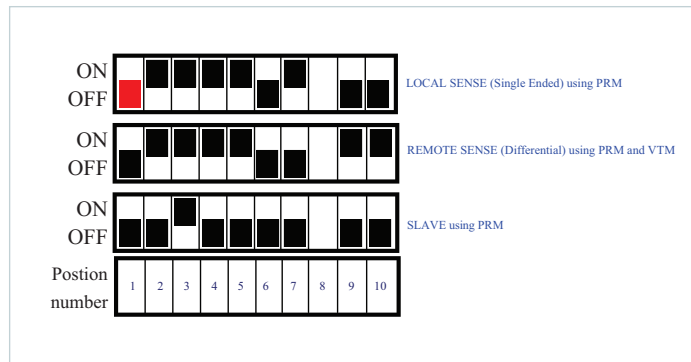
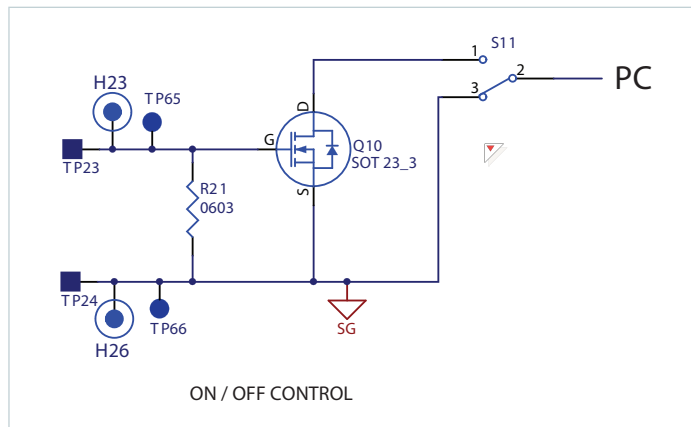

Figure 9 provides the illustration for how to configure the switch for each operating mode.

Common Features in all Modes of Operations

- On / off control to enable and disable the PRM® in the presence of input power.
 - Using switch S11 or
 - Open drain MOSFET using external circuitry or function generator
- Input filtering (inductor and ceramic capacitors)
- Output filtering (inductor and ceramic capacitors)
- Sockets for easy installation of input and output electrolytic capacitor
- Test points for current sensing
- Kelvin test points for measurement of input voltage, output voltage and all signal pins of the PRM.
- Sockets for each test point for easy installation of through-hole components and solid wires to facilitate the wiring to external circuitry and test equipment.

Figure 10.
ON / OFF control



Remote Sense Operating Mode using PRM®: Local Sensing (Single Ended)

Mode select switch S10 setting: keep the switch S10 setting at all positions as shown in following illustration.

Figure 11.
Local Sensing
(single ended)

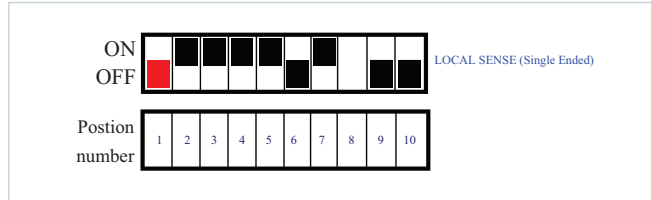

The following table describes the switch configuration.

Table 7.
Switch configuration
in local sensing

| Switch Position Number | ON or OFF | Connection |
|------------------------|------------|--|
| 1 | OFF | TM pin must be left open. This switch position cannot be put in the ON position. |
| 2 | ON | PR pin is connected to output of external error amplifier. |
| 3 | ON | IF pin is connected to output of external current sense amplifier to set constant current limit. |
| 4 | ON | RE pin is connected to input of the external voltage reference circuit to generate voltage reference for external error amplifier. |
| 5 | ON | VS pin is connected to power VCC of the op-amp and current sense IC. |
| 6 | OFF | NC pin must be left open. This switch position cannot be put in the ON position. |
| 7 | ON | PRM +OUT pin is connected to local sense (single ended) of the remote sense control circuitry. |
| 8 | Don't care | |
| 9 | OFF | See next Remote Sense Operation |
| 10 | OFF | See next Remote Sense Operation |

Figure 12.

Remote Sense: local sensing
(single ended) control circuitry
BLUE highlight =
Pre-installed component
GREEN highlight =
user installed component

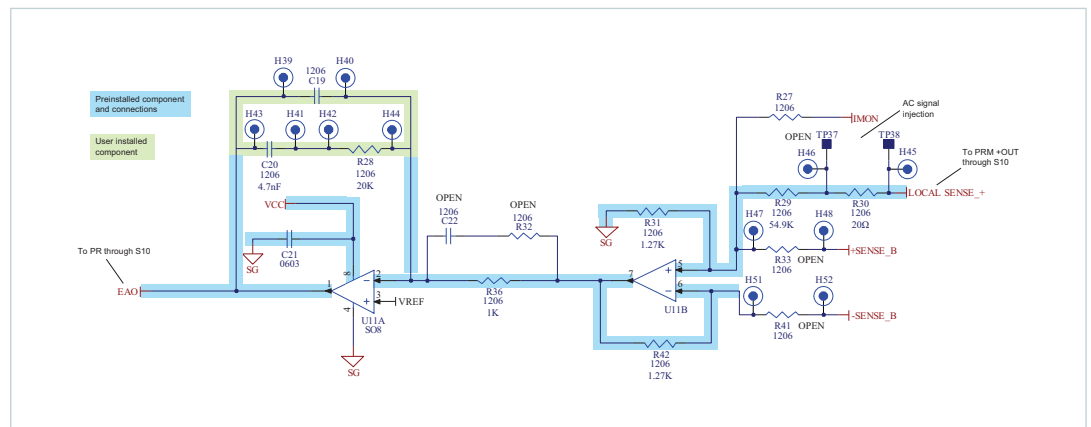

In this configuration, PRM operates in Remote Sense. PRM module output voltage is sensed through divider formed by R29 and R31. U11B is configured as buffer as shown in Figure 11 and provides the sense voltage to error amplifier U11A. R33, R41 and R27 are left open, reserved for differential sensing and current sensing. R29 is set to limit the upper trim range based on a maximum reference voltage of 1.25 V. Note that by default compensation components are not installed and required for operation. Default compensation components are provided with the board as described in a later section.

Remote Sense operating mode using PRM® and VTM®: Non-Isolated Remote Sensing (Differential Sensing)

Mode select switch S10 setting: keep the switch S10 setting at all positions as shown in the following illustration.

Figure 13.
Remote Sense
(differential)

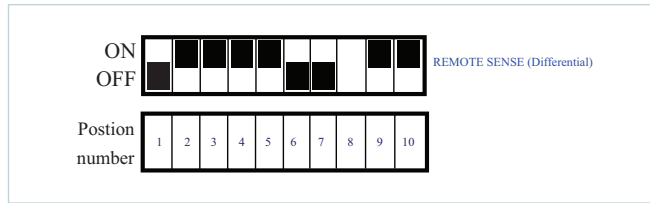

Note: To use this configuration, the VTM isolation must be broken by tying VTM -IN and VTM -OUT together.

The following table describes the switch configuration.

Table 8.
Switch configuration in
differential sensing

| Switch Position Number | ON or OFF | Connection |
|------------------------|------------|--|
| 1 | OFF | TM pin must be left open. This switch position cannot be put in the ON position. |
| 2 | ON | PR pin is connected to output of external error amplifier. |
| 3 | ON | IF pin is connected to output of external current sense amplifier to set the constant current limit. |
| 4 | ON | RE pin is connected to input of the external voltage reference circuit to generate voltage reference for external error amplifier. |
| 5 | ON | VS pin is connected to power VCC of the op-amp and current sense IC. |
| 6 | OFF | NC pin must be left open. This switch position cannot be put in the ON position. |
| 7 | OFF | PRM +OUT pin is NOT connected to local sense (single ended) of the remote sense control circuitry. |
| 8 | Don't care | |
| 9 | ON | VTM +OUT (+SENSE) pin is connected to positive input (+SENSE_B) of the differential buffer of remote sense control circuitry. |
| 10 | ON | VTM -OUT (-SENSE) pin is connected to negative input (-SENSE_B) of the differential buffer of remote sense control circuitry. |

Figure 14.

Remote Sense: non-isolated
remote sensing (differential)
control circuitry
BLUE highlight =
Pre-installed component
GREEN highlight =
user installed component

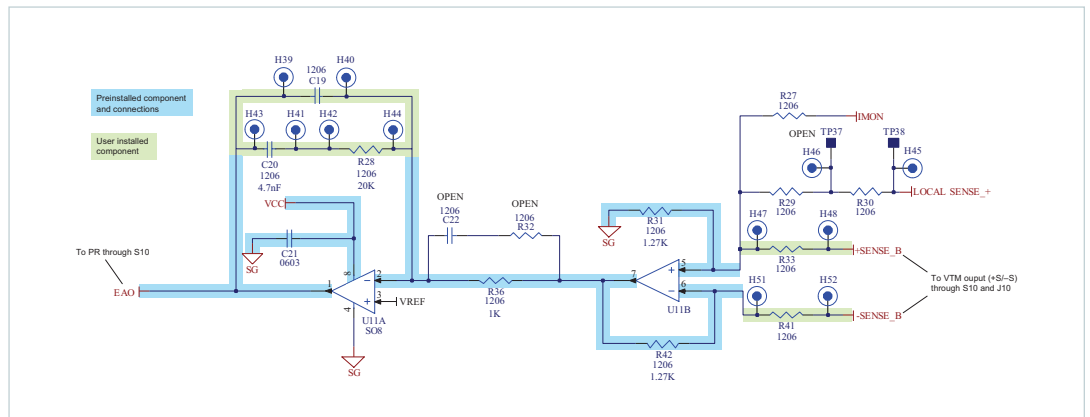

In this configuration, the PRM® and VTM® evaluation boards are connected together to form a PRM / VTM pair and regulation is performed at the VTM module output. The +SENSE and -SENSE connections are made at the VTM output through connector J10. This is a non-isolated configuration and therefore the VTM isolation must be broken by tying the VTM -OUT and VTM -IN pins together. The VTM evaluation board has provisions for easily breaking the isolation. U11B is configured as a differential amplifier with gain set for appropriate output voltage. R33 and R41 set the gain. POT R44 can be used to set the required voltage at the VTM output. Maximum output voltage can be set for maximum 1.25 V reference voltage. R33 and R41 is calculated using following equation.

$$R_{33} = R_{41} = \frac{V_{OUT_SET(MAX)} \cdot 1.27k\Omega}{1.25 V} \quad \text{Equation 1}$$

Where: $V_{OUT_SET(MAX)}$ is the maximum VTM output trim voltage

Please note that R33 and R41 are not populated by default. Sockets can be used to populate through-hole resistors R33 and R41.

In order to configure the evaluation boards for non-isolated remote sense the following steps must be taken:

1. Connect the PRM and VTM evaluation boards together
2. Configure the operating mode switch as described
3. Break the isolation by connecting VTM-IN and -OUT together
4. Calculate and install the appropriate differential sense resistors (R33 and R41)
5. Install compensation components C20 and R28

Remote Sense Compensation Components

By default, compensation components are not populated, and are required for operation. Please note that board comes with default through-hole compensation components C20 and R28 that can be used to get a baseline for Remote Sense operation. Sockets can be used for easy installation of C20 and R28. These components are not optimized and will have low bandwidth response. Transient response can be improved by adjusting the compensation components as outlined in the PRM datasheet.

It is recommended to use a network analyzer to measure the closed loop frequency response when adjusting compensation. The PRM and VTM boards provide test points which can be used to inject the network analyzer AC signal and measure the closed loop response.

For PRM Remote Sense mode (single ended local sense), test points TP37/TP38 and H46/H45 are in series between the PRM +OUT and the voltage sense resistors and should be used.

For PRM-VTM Remote Sense mode (differential sense) test points are provided on the VTM board in series with the +S connections (Labeled "AC Sig Inj +/-") and should be used.

Trim and Soft-start Adjustment in Remote Sense Operation

Trim and soft start adjustment in Remote Sense Operation is set by the reference voltage network shown below. The PRM evaluation board is normally configured for a 20 V to 55 V trim range. Trim POT R44 is used to trim the output voltage in Remote Sense Operation.

The slew rate of the output voltage during startup may be controlled by controlling the rate-of-rise of the voltage at VREF node. This can be achieved using soft-start capacitance C24. By default, C24 is populated with 0.1 uF ceramic capacitance. Sockets H55 and H56 can be used for installation of additional through-hole soft-start capacitance. It is not recommended to extend the soft start beyond 10msec.

Figure 15.
Voltage reference circuit

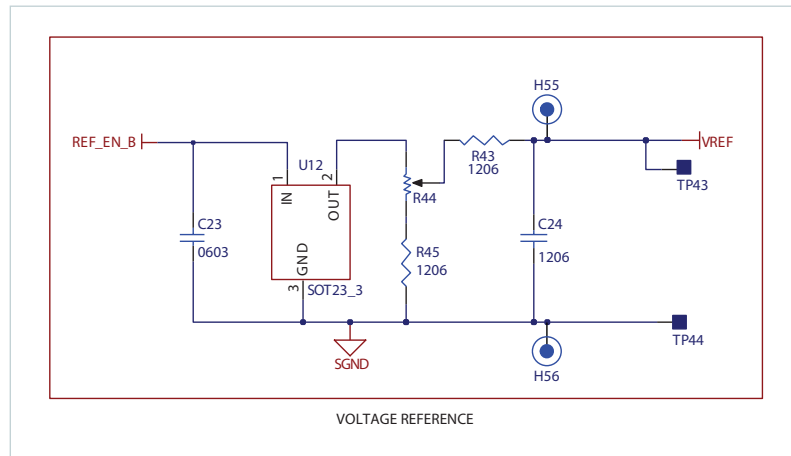

Current Limit Adjustment in Remote Sense Operation

In Remote Sense Operation, current feedback is provided externally. The current limit set point is a function of the current sense amplifier gain, the shunt resistor and the internal current limit threshold of PRM. Full chip PRM evaluation board has 5 mΩ current shunt whereas half chip PRM evaluation board has 10mΩ current shunt. The IFB current limit threshold is fixed at 2.0 V. The gain of the current sense amplifier can be changed per Equation 2 in order to adjust the current limit. Resistor R26 set the gain of the current sense amplifier. R25 is the current shunt.

$$G_{CS} = \frac{V_{IFB_IL}}{I_{LIMIT(SET)} \cdot R_{25}} \quad \text{Equation 2}$$

By default, R26 is installed for the current limit approximately 10% above rated output current.

The current limit setpoint can be changed by adjusting the value of R26 and appropriately setting the gain of the current sense IC.

Slave Operating Mode (Arrays)

Mode select switch S10 setting: keep the switch S10 setting at all positions as shown in the following illustration.

Figure 16.
Slave

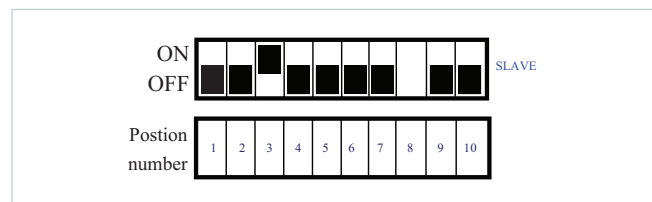

Slave operation is required for constructing arrays of parallel devices as described in the next section. Switch all the positions to OFF, except position #3. Slave PRMs receive their control signal (PR) from an external remote sense circuit. Switch at position #3 is on to enable the constant output current limit. External Remote Sense circuit controls the array of voltage.

Paralleling

The paralleling and current sharing capability of the devices can be demonstrated by stacking multiple evaluation board and interconnecting the inputs and outputs with standoffs of sufficient current rating to create a parallel array. See Figure 17 below. One board should be configured normally for Remote Sense operation and placed on top for easy access to control circuitry. The remaining PRMs should be configured as Slaves and placed underneath.

When paralleling PRMs, the PC, PR and SG pins should be connected together. Dual paralleling wire to board connectors (J17 and J18) are used for transferring signal pins (PC, PR and SG) in parallel operation from board to board. These connectors provide simple strip and insert option and accept 18-24 AWG solid wires. PR and SG wires can be twisted to minimize noise pick-up. Note that when using J17 and J18, SG pins will be connected together through an on board 1 OHM series resistors to decouple signal grounds.

VTM® boards can also be connected in parallel to create high power PRM-VTM arrays. VTM input and outputs need to be connected in parallel using same size standoffs. Each VTM requires a VC signal from a PRM® in order to start and it is recommended to connect one PRM VC to one VTM VC using the connector J13 when possible. If needed a single PRM VC can be used to drive up to two VTMs (will require additional off board connections).

Figure 17.
Paralleling of PRM
evaluation board

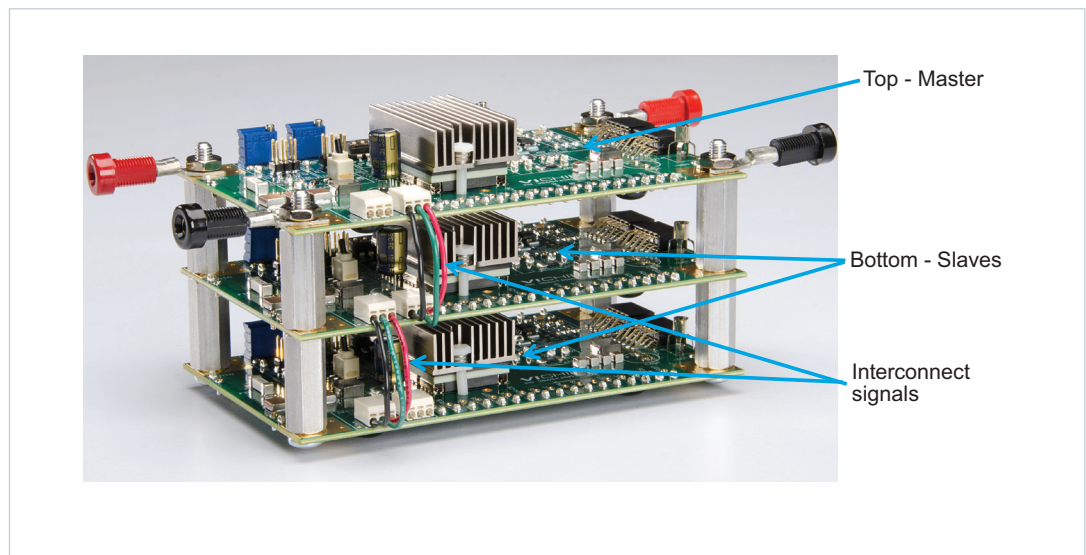

Conclusion

The PRM® evaluation board is a flexible tool which allows users to implement and perform basic testing on various configurations, including PRM-VTM® module combinations. This user guide covers some basic topics; however, it cannot describe every scenario. If additional information required, please contact Vicor Applications Engineering.

The Power Behind Performance



Стандарт Электрон Связь

Мы молодая и активно развивающаяся компания в области поставок электронных компонентов. Мы поставляем электронные компоненты отечественного и импортного производства напрямую от производителей и с крупнейших складов мира.

Благодаря сотрудничеству с мировыми поставщиками мы осуществляем комплексные и плановые поставки широчайшего спектра электронных компонентов.

Собственная эффективная логистика и склад в обеспечивает надежную поставку продукции в точно указанные сроки по всей России.

Мы осуществляем техническую поддержку нашим клиентам и предпродажную проверку качества продукции. На все поставляемые продукты мы предоставляем гарантию .

Осуществляем поставки продукции под контролем ВП МО РФ на предприятия военно-промышленного комплекса России , а также работаем в рамках 275 ФЗ с открытием отдельных счетов в уполномоченном банке. Система менеджмента качества компании соответствует требованиям ГОСТ ISO 9001.

Минимальные сроки поставки, гибкие цены, неограниченный ассортимент и индивидуальный подход к клиентам являются основой для выстраивания долгосрочного и эффективного сотрудничества с предприятиями радиоэлектронной промышленности, предприятиями ВПК и научно-исследовательскими институтами России.

С нами вы становитесь еще успешнее!

Наши контакты:

Телефон: +7 812 627 14 35

Электронная почта: sales@st-electron.ru

Адрес: 198099, Санкт-Петербург,
Промышленная ул, дом № 19, литера Н,
помещение 100-Н Офис 331