



Ramp-RM/LT DVK Hardware

USER'S GUIDE

VERSION 1.0

global solutions: local support™

Americas: +1-800-492-2320 Option 2

Europe: +44-1628-858-940

Hong Kong: +852-2923-0610

wireless.support@lairdtech.com

www.lairdtech.com/ramp

Ramp-RM/LT DVK Hardware

Version 1.0

REVISION HISTORY

Version	Date	Changes
1.0	30 April 2014	Initial Release

Ramp-RM/LT DVK Hardware

Version 1.0

CONTENTS

Contents	3
Introduction	4
Hardware	4
RM/LT Series DVK Board	5
Power Switch	7
Jumper Usage	7
Interfacing the RM DVK to RS232 hardware	8

Ramp-RM/LT DVK Hardware

Version 1.0

INTRODUCTION

The Laird RAMP-RM/LT Development Kit is the standard interface for testing and software development on all Laird RAMP-RM/LT products. The kit includes two RAMP modules and two evaluation boards (EVK) with serial interfaces for programming and test control via the Laird Configuration Utility running on a Windows PC. This application note covers the hardware specifications of the RAMP-RM/LT Development Kit.

HARDWARE

This section details the Development Kit boards for the RM/LT series RAMP modules including the following:

RM024	LT1110		LT2510 (EOL)	
DVK-RM024-FCC DVK-RM024-CE	DVK-PRM210 DVK-PRM211 DVK-PRM220	DVK-PRM221 DVK-PRM240 DVK-PRM241	DVK-PRM110 DVK-PRM111 DVK-PRM112 DVK-PRM113	DVK-PRM120 DVK-PRM121 DVK-PRM122 DVK-PRM123

The RM024 family of modules can be evaluated using one of the two RM024 development kit part numbers. The individual RM024 part numbers that can be evaluated with each DVK-RM024 kit are listed below along with the required configuration.

Table 1: RM024 part numbers for the DVK-RM024-FCC dev kit

DVK-RM024-FCC			
RM024 p/n	Requirements		Settings/Configuration
RM024-S125-C-xx	EEPROM	Enable u.FL for external antenna	Set address 0xC1 bit 5 == 1
	Hardware	Use external antenna (incl.)	Connect external antenna to u.FL
RM024-S125-M-xx	EEPROM	Enable integrated chip antenna	Set address 0xC1 bit 5 == 0
	Hardware	None	N/A
RM024-P125-C-xx	EEPROM	Enable u.FL for external antenna	Set address 0xC1 bit 5 == 1
	Hardware	Use external antenna (incl.)	Connect external antenna to u.FL
RM024-P125-M-xx	EEPROM	Enable integrated chip antenna	Set address 0xC1 bit 5 == 0
	Hardware	None	N/A
RM024-S10-C-xx	EEPROM	Enable u.FL for external antenna	Set address 0xC1 bit 5 == 1
	EEPROM	Set output to low power	Set address 0x63 == 0x03
	Hardware	Use external antenna (incl.)	Connect external antenna to u.FL
RM024-S10-M-xx	EEPROM	Enable integrated chip antenna	Set address 0xC1 bit 5 == 0
	EEPROM	Set output to low power	Set address 0x63 == 0x03
	Hardware	None	N/A
RM024-P10-C-xx	EEPROM	Enable u.FL for external antenna	Set address 0xC1 bit 5 == 1
	EEPROM	Set output to low power	Set address 0x63 == 0x03
	Hardware	Use external antenna (incl.)	Connect external antenna to u.FL
RM024-P10-M-xx	EEPROM	Enable integrated chip antenna	Set address 0xC1 bit 5 == 0
	EEPROM	Set output to low power	Set address 0x63 == 0x03
	Hardware	None	N/A

Ramp-RM/LT DVK Hardware

Version 1.0

Table 2: RM024 part numbers for the DVK-RM024-CE dev kit

DVK-RM024-CE			
RM024 p/n	Requirements		Settings/Configuration
RM024-S10-C-xx	EEPROM	Enable u.FL for external antenna	Set address 0xC1 bit 5 == 1
	Hardware	Use external antenna (incl.)	Connect external antenna to u.FL
RM024-S10-M-xx	EEPROM	Enable integrated chip antenna	Set address 0xC1 bit 5 == 0
	Hardware	None	N/A
RM024-P10-C-xx	EEPROM	Enable u.FL for external antenna	Set address 0xC1 bit 5 == 1
	Hardware	Use external antenna (incl.)	Connect external antenna to u.FL
RM024-P10-M-xx	EEPROM	Enable integrated chip antenna	Set address 0xC1 bit 5 == 0
	Hardware	None	N/A

Note: RM024-x50, 50 mW CE modules have been replaced by the RM024-x10 modules due to changes to CE regulations, see EN 300 328 V1.7.1 for more information.

RM/LT Series DVK Board

The RM and LT series DVK board is provided so the developer can use a standard PC interface to operate the transceivers and to aid in system integration. It uses an RS232 or USB data format to interface to the transceiver.

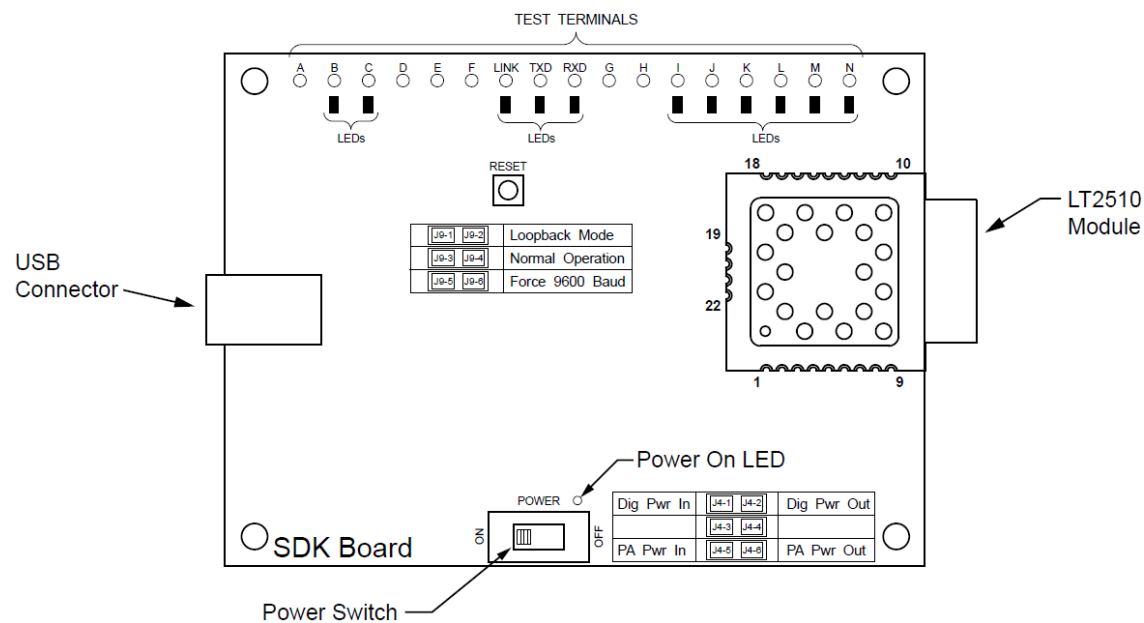

Figure 1: DVK Board with USB Connector

Ramp-RM/LT DVK Hardware

Version 1.0

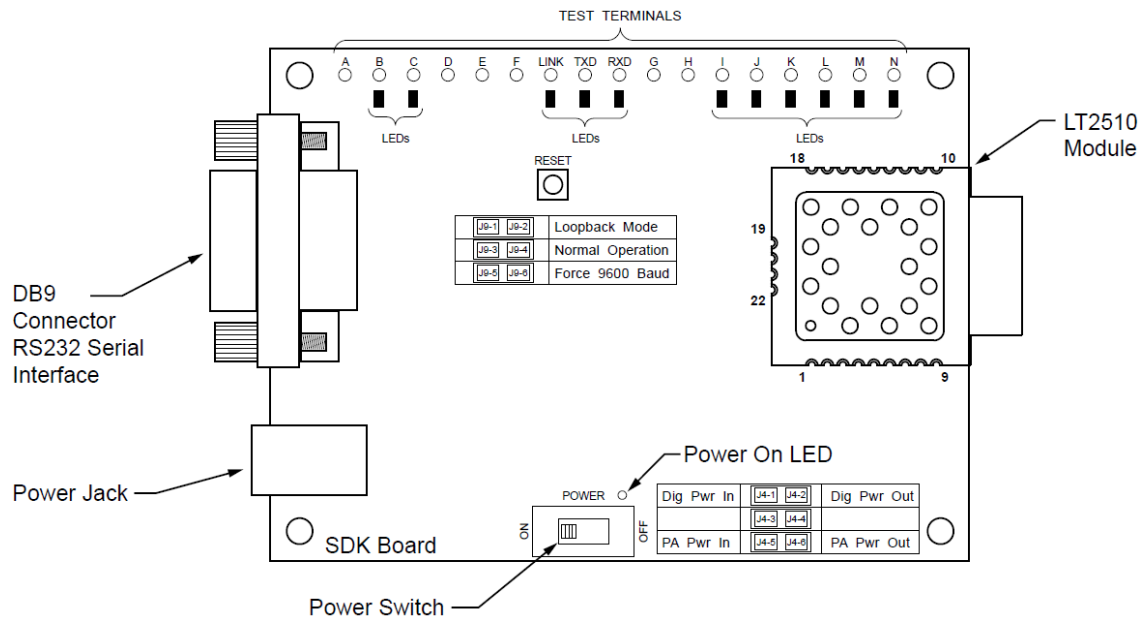

Figure 2: DVK Board with DB9 Connector

Note: The LEDs located on the front edge of the board continuously show the configuration and operation of the DVK board. Refer to [Table 3](#) for definitions of the LEDs, and

Ramp-RM/LT DVK Hardware

Version 1.0

Table 4 for DB9 connector pin assignments.

Table 3: RM024 DVK LEDs

LED	LED Color	Purpose
B	Green	This LED illuminates when GIO_6 is low.
C	Red	This LED illuminates when GIO_4 is low.
I	Green	This LED illuminates when 9600_BAUD is high.
J	Red	This LED illuminates when GIO_7 is low.
K	Red	This LED illuminates when GIO_3 is low.
L	Green	This LED illuminates when GIO_2 is low.
M	Red	This LED illuminates when GIO_1 is low.
N	Green	This LED illuminates when GIO_0 is low.
LINK	Red	This LED illuminates when In_Range is high.
TXD	Green	This LED illuminates when TXD is low.
RXD	Red	This LED illuminates when RXD is low.
Power	Green	This LED illuminates when the POWER switch is turned on and the module is receiving power.

Ramp-RM/LT DVK Hardware

Version 1.0

Table 4: DB9 Pins

DB9 Pin	Signal Name	Description	Direction
1	DCD	Data Carrier Detect	I
2	RXD	Received Data	I
3	TXD	Transmitted Data	O
4	DTR	Data Terminal Ready	O
5	GND	Signal Ground	
6	DSR	Data Set Ready	I
7	RTS	Request to Send	O
8	CTS	Clear to Send	I
9	RI	Ring Indicator	I

Note: I/O direction is relative to the PC.

Power Switch

The RM024 DVK board is equipped with a power switch. Use this switch to turn the power to the board on and off. This power switch should be turned **off** when the USB or power supply cable is connected or disconnected to prevent possible damage to the board. When set to **OFF**, power is removed from the RM series transceiver and the development board.

Jumper Usage

The RM024 DVK board utilizes a set of jumpers to accomplish certain tasks. There are two sets of jumpers, the J4 set and the J9 set.

Jumper Set J4

Use the J4 set of jumpers to complete the circuits that supply power to the radio. There are two jumpers and **both jumpers MUST be properly installed** for the module to operate. A jumper **MUST** be installed on J4-1 and J4-2 to supply power to the radio itself. Another jumper **MUST** also be installed on J4-5 and J4-6 to supply power to the power amplifier.

Jumper Set J9

Use the J9 set of jumpers to control how the development kit board operates. Only one jumper is used with this jumper set. There are three operational modes:

- **Loopback** – Install the jumper on pins J9-1 and J9-2 to operate the unit in loopback mode. This means that the radio receives data and then transmits the same data. The loop is on the serial interface of the module and points back to the radio. This jumper is useful for range testing.
- **Normal Operation** – Install the jumper on pins J9-3 and J9-4 to operate the unit in its normal mode. This means that the radio operates however it is configured using the DVK software application.
- **Force 9600 Baud** – Install the jumper on pins J9-5 and J9-6 to operate the unit only at 9600 Baud. This is a recovery mode that is used when the user is unable to communicate with the radio. This mode places the unit in a known operating state so the user can go in and access the programmed data via the development software.

Ramp-RM/LT DVK Hardware

Version 1.0

Table 5: J4 and J9 Jumper Pins

Jumper ID	Label	Usage
J4-1	Dig Pwr In	A jumper MUST be connected to these two pins for operation. This is the power supply circuit for the radio.
J4-2	Dig Pwr Out	
J4-3	Not Used	Not Used
J4-4	Not Used	Not Used
J4-5	PA Pwr In	A jumper MUST be connected to these two pins for operation. This is the power supply circuit for the power amplifier.
J4-6	PA Pwr Out	
J9-1	Loopback	To configure the radio for loopback operation, connect a jumper to these two pins. Note: You may NOT connect a jumper to the Normal Operation or Force 9600 Baud pins at the same time.
J9-2	Loopback	
J9-3	Normal Operation	During normal operation, connect a jumper to these two pins.
J9-4	Normal Operation	Note: You may NOT connect to the Loopback or Force 9600 Baud pins at the same time.
J9-5	Force 9600 Baud	To force the radio to operate at 9600 Baud, connect a jumper to these two pins. Note: You may NOT connect to the Loopback or Normal Operation pins at the same time.

Interfacing the RM DVK to RS232 Hardware

The development kit serial board is a DCE (Data Communications Equipment) device. A DCE device is wired to the interface directly with a DTE (Data Terminal Equipment) device. Typically, a DTE device is a PC, while a DCE device is a peripheral. To interface a DCE device to other DCE device or a DTE device to another DTE device, a null modem is required. The null modem swaps pins to convert a DCE device to a DTE device, and vice-versa. Normally, a null modem consists of a female and a male DB9 connector. A typical null modem configuration is shown in Table 6.

Table 6: Null modem pin configuration

DB9 Pin	Signal	DCE Direction	DTE Pin	Signal Name	DTE Direction	Null Modem Female DB9
1	DCD	O	1	I	1	4 or NC
2	RXD	O	2	I	2	3
3	TXD	I	3	O	3	2
4	DTR	I	4	O	4	6 and 1 or NC
5	GND	5	GND	5		
6	DSR	O	6	I	6	4 or NC
7	RTS	I	7	O	7	8
8	CTS	O	8	I	8	7
9	RI	O	9	I	9	NC



**Стандарт
Электрон
Связь**

Мы молодая и активно развивающаяся компания в области поставок электронных компонентов. Мы поставляем электронные компоненты отечественного и импортного производства напрямую от производителей и с крупнейших складов мира.

Благодаря сотрудничеству с мировыми поставщиками мы осуществляем комплексные и плановые поставки широчайшего спектра электронных компонентов.

Собственная эффективная логистика и склад в обеспечивает надежную поставку продукции в точно указанные сроки по всей России.

Мы осуществляем техническую поддержку нашим клиентам и предпродажную проверку качества продукции. На все поставляемые продукты мы предоставляем гарантию .

Осуществляем поставки продукции под контролем ВП МО РФ на предприятия военно-промышленного комплекса России , а также работаем в рамках 275 ФЗ с открытием отдельных счетов в уполномоченном банке. Система менеджмента качества компании соответствует требованиям ГОСТ ISO 9001.

Минимальные сроки поставки, гибкие цены, неограниченный ассортимент и индивидуальный подход к клиентам являются основой для выстраивания долгосрочного и эффективного сотрудничества с предприятиями радиоэлектронной промышленности, предприятиями ВПК и научно-исследовательскими институтами России.

С нами вы становитесь еще успешнее!

Наши контакты:

Телефон: +7 812 627 14 35

Электронная почта: sales@st-electron.ru

Адрес: 198099, Санкт-Петербург,
Промышленная ул, дом № 19, литера Н,
помещение 100-Н Офис 331