

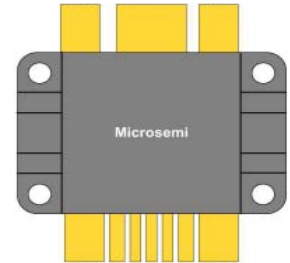

MOSFET Driver Hybrid

The DRF1200 hybrid includes a high power gate driver and the power MOSFET. The driver output can be configured as Inverting and Non-Inverting. It was designed to provide the system designer increased flexibility and lowered cost over a non-integrated solution.

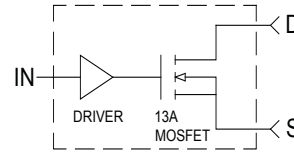

FEATURES

- Switching Frequency: DC TO 30MHz
- Low Pulse Width Distortion
- Single Power Supply
- 1V CMOS Schmitt Trigger Input 1V Hysteresis
- Inverting Non-Inverting Select
- RoHS Compliant 
- Switching Speed 3-4ns
- $B_{V_{ds}} = 1Kv$
- $I_{ds} = 13A$ Max
- $R_{ds(on)} \leq 0.90$ Ohm
- $P_D = 624W$

TYPICAL APPLICATIONS

- Class C, D and E RF Generators
- Switch Mode Power Amplifiers
- Pulse Generators
- Ultrasound Transducer Drivers
- Acoustic Optical Modulators

Driver Absolute Maximum Ratings

Symbol	Parameter	Min	Typ	Max	Unit
V_{DD}	Supply Voltage			15	V
IN, FN	Input Single Voltages			-.7 to +5.5	
$I_{O_{PK}}$	Output Current Peak			8	A
T_{JMAX}	Operating Temperature			175	°C

Driver Specifications

Symbol	Parameter	Min	Typ	Max	Unit
V_{DD}	Supply Voltage	10		15	V
IN	Input Voltage	3		5.5	
$IN_{(R)}$	Input Voltage Rising Edge		3		ns
$IN_{(F)}$	Input Voltage Falling Edge		3		
I_{DDQ}	Quiescent Current		2		mA
I_O	Output Current		8		A
C_{iss}	Input Capacitance		3		
R_{IN}	Input Parallel Resistance		1		MΩ
$V_{TH(on)}$	Input, Voltage Threshold Low (See truth table)	0.8		1.1	V
$V_{TH(off)}$	Input, Voltage Threshold High (See truth table)	1.9		2.2	
T_{DLY}	Time Delay (throughput)		38		ns
t_r	Rise Time		7.5		ns
t_f	Fall Time		7.5		

Driver Output Characteristics

Symbol	Parameter	Min	Typ	Max	Unit
C_{out}	Output Capacitance		2500		pF
R_{out}	Output Resistance		.8		Ω
L_{out}	Output Inductance		3		nH
F_{MAX}	Operating Frequency CL = 3000nF + 50 Ω	30			MHz
F_{MAX}	Operating Frequency RL = 50 Ω	50			

Driver Thermal Characteristics

Symbol	Parameter	Min	Typ	Max	Unit
$R_{\theta JC}$	Thermal Resistance Junction to Case		1.5		$^{\circ}\text{C}/\text{W}$
$R_{\theta JHS}$	Thermal Resistance Junction to Heat Sink		2.5		
T_{JSTG}	Storage Temperature		-55 to 150		$^{\circ}\text{C}$
P_{DJHS}	Maximum Power Dissipation @ $T_{SINK} = 25^{\circ}\text{C}$		60		W
P_{DJC}	Total Power Dissipation @ $T_C = 25^{\circ}\text{C}$		100		

MOSFET Absolute Maximum Ratings

Symbol	Parameter	Min	Typ	Max	Unit
BV_{DSS}	Drain Source Voltage	1000			V
I_D	Continuous Drain Current $T_{HS} = 25^{\circ}\text{C}$			13	A
$R_{DS(on)}$	Drain-Source On State Resistance		0.90		Ω
T_{Jmax}	Operating Temperature			175	$^{\circ}\text{C}$

MOSFET Dynamic Characteristics

Symbol	Parameter	Min	Typ	Max	Unit
C_{iss}	Input Capacitance		2000		pF
C_{oss}	Output Capacitance		165		
C_{rss}	Reverse Transfer Capacitance		75		

MOSFET Thermal Characteristics

Symbol	Parameter	Min	Typ	Max	Unit
$R_{\theta JC}$	Thermal Resistance Junction to Case		0.095		$^{\circ}\text{C}/\text{W}$
$R_{\theta JHS}$	Thermal Resistance Junction to Heat Sink		0.25		
T_{JSTG}	Storage Temperature		-55 to 150		$^{\circ}\text{C}$
P_{DHS}	Maximum Power Dissipation @ $T_{SINK} = 25^{\circ}\text{C}$		600		W
P_{DC}	Total Power Dissipation @ $T_C = 25^{\circ}\text{C}$		1580		

Microsemi reserves the right to change, without notice, the specifications and information contained herein.

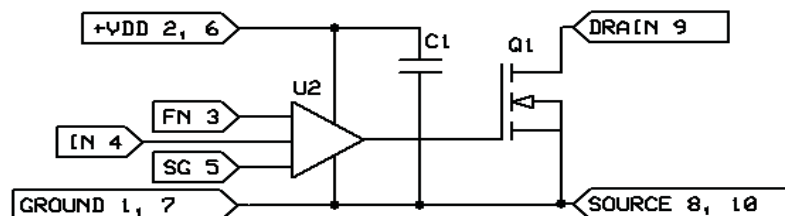

Figure 1, DRF1200 Simplified Circuit Diagram

The Simplified DRF1200 Circuit Diagram is illustrated above. By including the driver high speed by-pass capacitor (C1), the contribution to the internal parasitic loop inductance of the driver output is greatly reduced. This, coupled with the tight geometry of the hybrid, allows optimal gate drive to the MOSFET. This low parasitic approach, coupled with the Schmitt trigger input (IN), Kelvin signal ground (SG) and the Anti-Ring Function, provide improved stability and control in Kilowatt to Multi-Kilowatt, high Frequency applications. Both the FN and IN pins are referenced to the Kelvin ground (SG.) The signal is then applied to the intermediate drivers and level shifters; this section contains proprietary circuitry designed specifically for the ring abatement. The power drivers provide high current to the gate of the MOSFETS.

The Function (FN, pin 3) is the invert or non-invert select Pin, it is Internally held high.

Truth Table *Referenced to SG		
FN (pin 3)*	IN (pin 4)*	MOSFET
HIGH	HIGH	ON
HIGH	LOW	OFF
LOW	HIGH	OFF
LOW	LOW	ON

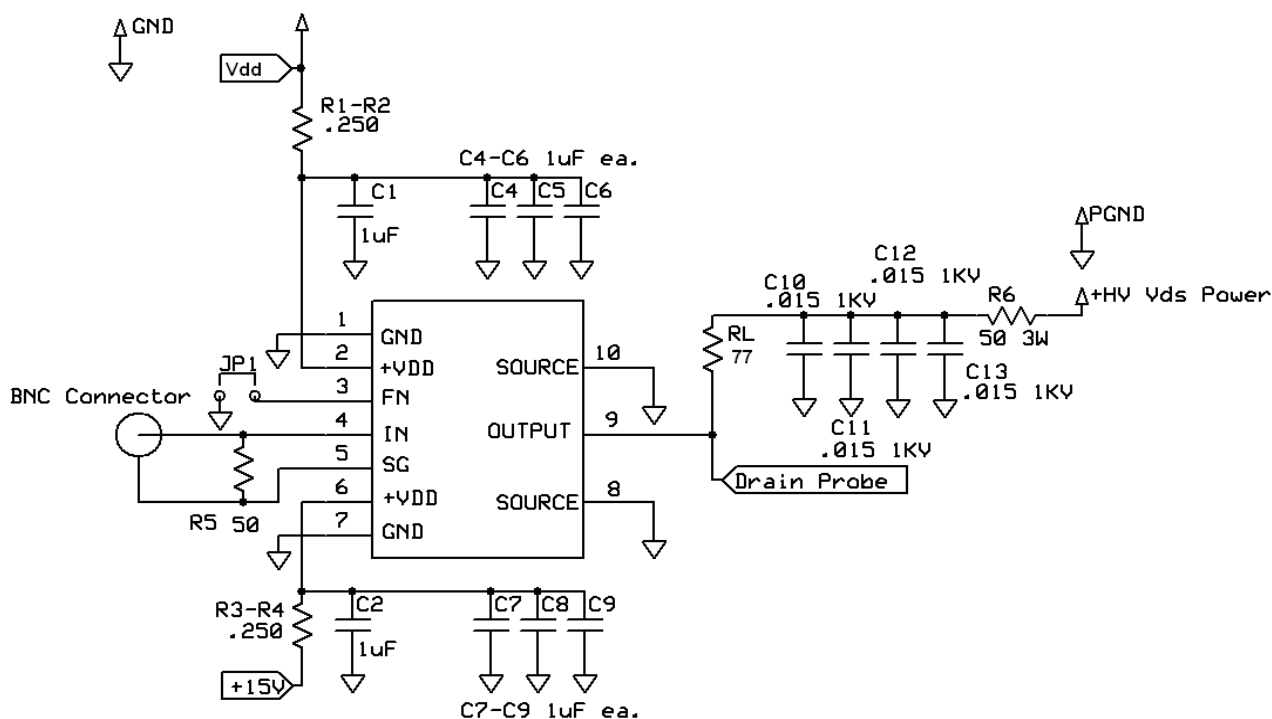
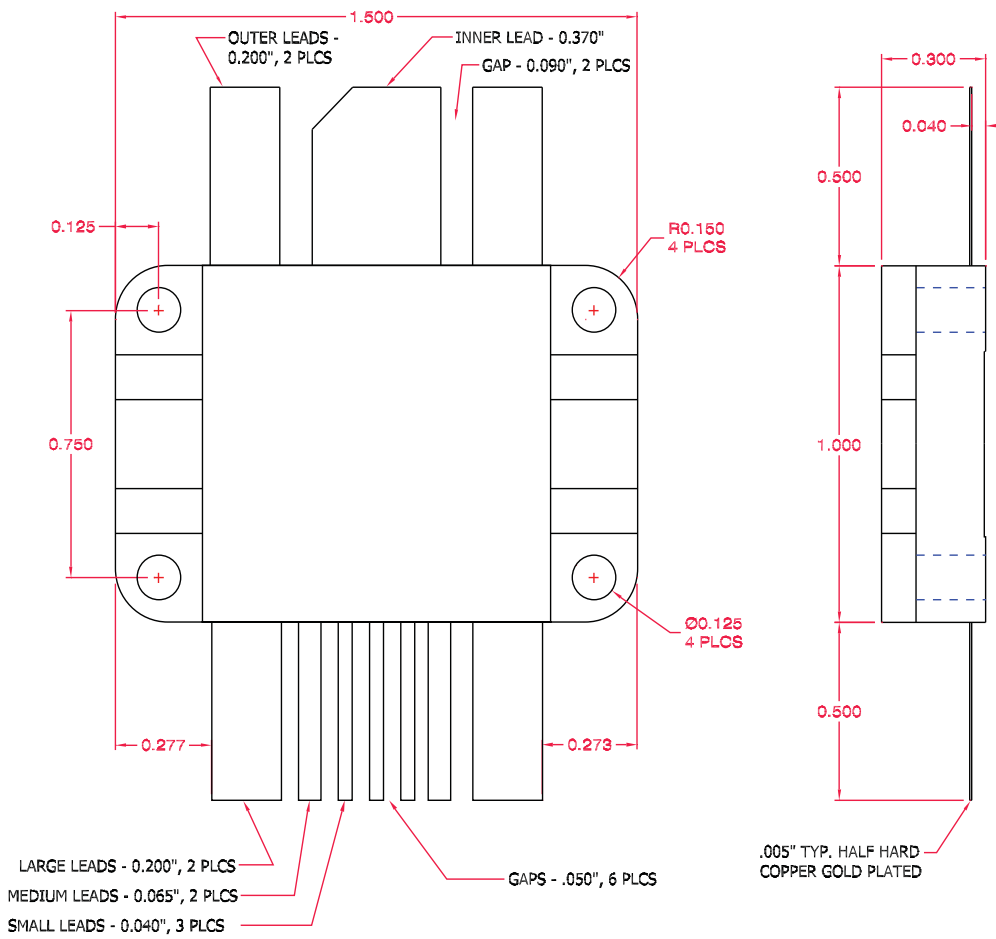

Figure 2, DRF1200 Test Circuit

The Test Circuit illustrated above was used to evaluate the DRF1200 (available as an evaluation Board DRF12XX / EVALSW.) The input control signal is applied to the DRF1200 via IN(4) and SG(5) pins using RG188. This provides excellent noise immunity and control of the signal ground currents.

The $+V_{DD}$ inputs (2,6) are by-passed (C1, C2, C4-C9), this is in addition to the internal by-passing mentioned previously. The capacitors used for this function must be capable of supporting the RMS currents and frequency of the gate load. R_L set for I_{DM} at V_{DS} max this load is used to evaluate the output performance of the DRF1201.

Pin Assignments	
Pin 1	Ground
Pin 2	+Vdd
Pin 3	FN
Pin 4	IN
Pin 5	SG
Pin 6	+Vdd
Pin 7	Ground
Pin 8	Source
Pin 9	Drain
Pin 10	Source



All dimensions are ± .005

Figure 3, DRF1200 Mechanical Outline



Стандарт Электрон Связь

Мы молодая и активно развивающаяся компания в области поставок электронных компонентов. Мы поставляем электронные компоненты отечественного и импортного производства напрямую от производителей и с крупнейших складов мира.

Благодаря сотрудничеству с мировыми поставщиками мы осуществляем комплексные и плановые поставки широчайшего спектра электронных компонентов.

Собственная эффективная логистика и склад в обеспечивает надежную поставку продукции в точно указанные сроки по всей России.

Мы осуществляем техническую поддержку нашим клиентам и предпродажную проверку качества продукции. На все поставляемые продукты мы предоставляем гарантию .

Осуществляем поставки продукции под контролем ВП МО РФ на предприятия военно-промышленного комплекса России , а также работаем в рамках 275 ФЗ с открытием отдельных счетов в уполномоченном банке. Система менеджмента качества компании соответствует требованиям ГОСТ ISO 9001.

Минимальные сроки поставки, гибкие цены, неограниченный ассортимент и индивидуальный подход к клиентам являются основой для выстраивания долгосрочного и эффективного сотрудничества с предприятиями радиоэлектронной промышленности, предприятиями ВПК и научно-исследовательскими институтами России.

С нами вы становитесь еще успешнее!

Наши контакты:

Телефон: +7 812 627 14 35

Электронная почта: sales@st-electron.ru

Адрес: 198099, Санкт-Петербург,
Промышленная ул, дом № 19, литера Н,
помещение 100-Н Офис 331