

Dual-channel HOTLink II™ Transceiver

Features

- Second-generation HOTLink® technology
 - Compliant to multiple standards
 - ESCON, DVB-ASI, Fibre Channel, and Gigabit Ethernet (IEEE 802.3z)
 - CPRI™ compliant
 - 8B/10B encoded or 10-bit unencoded data
- Dual-channel transceiver operates from 195- to 1500-MBd serial data rate
 - Aggregate throughput of 6 Gbps
- Selectable parity check/generate
- Selectable dual-channel bonding option
 - One 16-bit channels
- Skew alignment support for multiple bytes of offset
- Selectable I/O clocking options
- MultiFrame™ receive framer
 - Bit and byte alignment
 - Comma or full K28.5 detect
 - Single- or multi-byte framer for byte alignment
 - Low-latency option
- Synchronous LVTTTL parallel interface
- Internal phase-locked loops (PLLs) with no external PLL components
- Optional phase-align buffer in transmit path
- Optional elasticity buffer in receive path
- Dual differential positive ECL (PECL) compatible serial inputs per channel
 - Internal DC-restoration
- Dual differential PECL-compatible serial outputs per channel
 - Source matched for 50-Ω transmission lines
 - No external bias resistors required
 - Signaling-rate controlled edge-rates
- Compatible with
 - Fiber optic modules
 - Copper cables
 - Circuit board traces
- JTAG boundary scan
- Built-in self-test (BIST) for at-speed link testing
- Per-channel link quality indicator
 - Analog signal detect
 - Digital signal detect
- Low power 1.8 W at 3.3-V typical
- Single 3.3 V supply
- 196-ball BGA
- Pb-free package
- 0.25-μm BiCMOS technology

Functional Description

The CYP15G0201DXB dual-channel HOTLink II™ transceiver is a point-to-point or point-to-multipoint communications building block allowing the transfer of data over high-speed serial links (optical fiber, balanced, and unbalanced copper transmission lines) at signaling speeds ranging from 195- to 1500-MBd per serial link.

Figure 1. HOTLink II™ System Connections

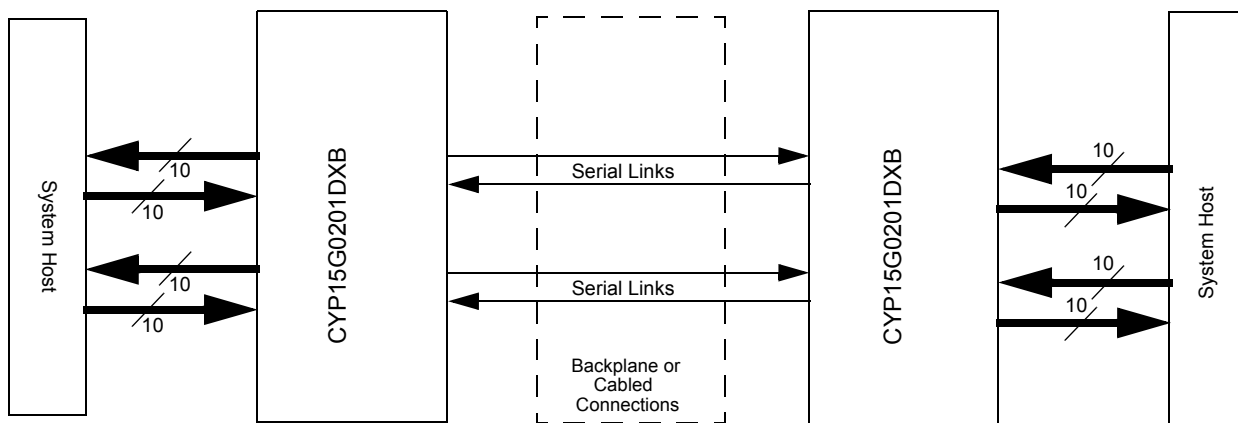

The CYP15G0201DXB operates from 195 to 1500 MBd.

The two channels may be combined to allow transport of wide buses across significant distances with minimal concern for offsets in clock phase or link delay. Each transmit channel accepts parallel characters in an input register, encodes each character for transport, and converts it to serial data. Each receive channel accepts serial data and converts it to parallel data, decodes the data into characters, and presents these characters to an Output Register. Figure 1 on page 1 illustrates typical connections between independent host systems and corresponding CYP15G0201DXB parts. As a second-generation HOTLink device, the CYP15G0201DXB extends the HOTLink family with enhanced levels of integration and faster data rates, while maintaining serial-link compatibility (data, command, and BIST) with other HOTLink devices.

The transmit (TX) section of the CYP15G0201DXB Dual HOTLink II consists of two byte-wide channels that can be operated independently or bonded to form wider buses. Each channel can accept either 8-bit data characters or pre-encoded 10-bit transmission characters. Data characters are passed from the Transmit Input Register to an embedded 8B/10B Encoder to improve their serial transmission characteristics. These encoded characters are then serialized and output from dual Positive ECL (PECL) compatible differential transmission-line drivers at a bit-rate of either 10 or 20 times the input reference clock.

The receive (RX) section of the CYP15G0201DXB Dual HOTLink II consists of two byte-wide channels that can be operated independently or synchronously bonded for greater bandwidth. Each channel accepts a serial bit-stream from one of two PECL-compatible differential line receivers and, using a

completely integrated PLL clock synchronizer, recovers the timing information necessary for data reconstruction. Each recovered bit-stream is deserialized and framed into characters, 8B/10B decoded, and checked for transmission errors. Recovered decoded characters are then written to an internal Elasticity Buffer, and presented to the destination host system. The integrated 8B/10B encoder/decoder may be bypassed for systems that present externally encoded or scrambled data at the parallel interface.

For those systems using buses wider than a single byte, the two independent receive paths can be bonded together to allow synchronous delivery of data across a two-byte-wide (16-bit) path.

The parallel I/O interface may be configured for numerous forms of clocking to provide the highest flexibility in system architecture. In addition to clocking the transmit path interfaces from one of multiple sources, the receive interface may be configured to present data relative to a recovered clock or to a local reference clock.

Each transmit and receive channel contains independent BIST pattern generators and checkers. This BIST hardware allows at-speed testing of the high-speed serial data paths in each transmit and receive section, and across the interconnecting links.

HOTLink II devices are ideal for a variety of applications where parallel interfaces can be replaced with high-speed, point-to-point serial links. Some applications include interconnecting backplanes on switches, routers, base-stations, servers and video transmission systems.

Transceiver Logic Block Diagram

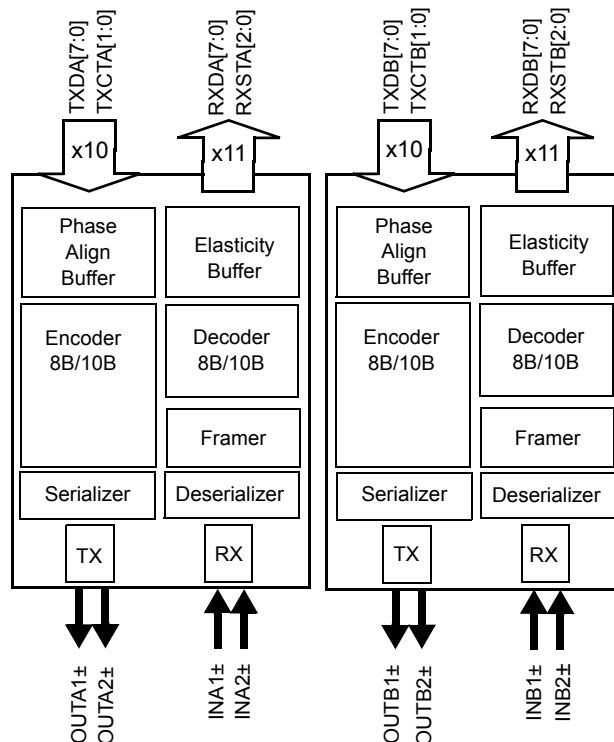

Contents

Pin Configuration	4	AC Test Loads and Waveforms	33
Pin Configuration	5	CYP15G0201DXB AC Characteristics	34
Pin Descriptions	6	Switching Waveforms	36
CYP15G0201DXB HOTLink II Operation	13	Switching Waveforms	37
CYP15G0201DXB Transmit Data Path	13	X3.230 Codes and Notation Conventions	41
Transmit Modes	15	Notation Conventions	41
Transmit BIST	18	8B/10B Transmission Code	41
Serial Output Drivers	18	Transmission Order	41
Transmit PLL Clock Multiplier	19	Valid and Invalid Transmission Characters	41
CYP15G0201DXB Receive Data Path	19	Use of the Tables for Generating Transmission	
Serial Line Receivers	19	Characters	42
Signal Detect/Link Fault	20	Use of the Tables for Checking the Validity of	
Clock/Data Recovery	21	Received Transmission Characters	42
Deserializer/Framer	21	Ordering Information	48
8B/10B Decoder Block	22	Ordering Code Definitions	48
Receive BIST Operation	22	Package Diagram	49
Receive Elasticity Buffer	23	Acronyms	50
Receive Modes	23	Document Conventions	50
Power Control	24	Units of Measure	50
Output Bus	25	Document History Page	51
Parity Generation	25	Sales, Solutions, and Legal Information	53
Receive Synchronization State Machine When		Worldwide Sales and Design Support	53
Channel Bonding is Enabled	26	Products	53
JTAG Support	31	PSoC® Solutions	53
Maximum Ratings	32	Cypress Developer Community	53
Operating Range	32	Technical Support	53
CYP15G0201DXB DC Electrical Characteristics	32		

Pin Configuration

Top View ^[1]

	1	2	3	4	5	6	7	8	9	10	11	12	13	14
A	V _{CC}	INA2+	OUTA2-	V _{CC}	INA1+	OUTA1-	V _{CC}	V _{CC}	INB2+	OUTB2-	V _{CC}	INB1+	OUTB1-	V _{CC}
B	TDO	INA2-	OUTA2+	V _{CC}	INA1-	OUTA1+	NC	NC	INB2-	OUTB2+	V _{CC}	INB1-	OUTB1+	BOE[3]
C	NC	RFEN	V _{CC}	LPEN	RXLE	RXRATE	GND	GND	SPDSEL	PARCTL	RFMODE	V _{CC}	SDASEL	BOE[2]
D	V _{CC}	V _{CC}	NC	TXRATE	RXMODE [1]	RXMODE [0]	GND	GND	TCLK	TDI	INSELB	INSELA	V _{CC}	V _{CC}
E	BISTLE	FRAM CHAR	TXMODE [1]	TXMODE [0]	BOE[0]	BOE[1]	GND	GND	TXOPB	TXPERB	TXCKSEL	RXCKSEL	$\overline{\text{TRSTZ}}$	TMS
F	DECMODE	OELE	RXCLKC+	RXSTA[2]	RXSTA[1]	GND	GND	GND	GND	TXDB[4]	TXDB[3]	TXDB[2]	TXDB[1]	TXDB[0]
G	V _{CC}	NC	GND	GND	GND	GND	GND	GND	GND	GND	GND	GND	NC	V _{CC}
H	V _{CC}	NC	GND	GND	GND	GND	GND	GND	GND	GND	GND	GND	NC	V _{CC}
J	RXSTA[0]	RXOPA	RXDA[0]	RXDA[1]	RXDA[2]	GND	GND	GND	GND	TXCTB[0]	TXCTB[1]	TXDB[7]	TXDB[6]	TXDB[5]
K	RXDA[3]	RXDA[4]	RXDA[5]	RXDA[6]	TXDA[4]	TXCLKA	GND	GND	NC	RXOPB	RXCLKB+	RXCLKB-	$\overline{\text{LFIB}}$	TXCLKB
L	V _{CC}	V _{CC}	RXDA[7]	$\overline{\text{LFIA}}$	TXDA[3]	TXOPA	GND	GND	SCSEL	RXSTB[2]	RXSTB[1]	RXDB[7]	V _{CC}	V _{CC}
M	RXCLKA-	TXCTA[1]	V _{CC}	NC	TXDA[2]	TXPERA	GND	GND	$\overline{\text{TXRST}}$	NC	RXSTB[0]	V _{CC}	RXDB[5]	RXDB[6]
N	RXCLKA+	TXCTA[0]	TXDA[6]	V _{CC}	TXDA[1]	NC	NC	NC	REFCLK-	TXCLKO+	V _{CC}	RXDB[2]	RXDB[3]	RXDB[4]
P	V _{CC}	TXDA[7]	TXDA[5]	V _{CC}	TXDA[0]	NC	V _{CC}	V _{CC}	REFCLK+	TXCLKO-	V _{CC}	RXDB[1]	RXDB[0]	V _{CC}

Note

1. NC = Do not connect.

Pin Configuration

Bottom View^[1]

14	13	12	11	10	9	8	7	6	5	4	3	2	1	
V _{CC}	OUTB1-	INB1+	V _{CC}	OUTB2-	INB2+	V _{CC}	V _{CC}	OUTA1-	INA1+	V _{CC}	OUTA2-	INA2+	V _{CC}	A
BOE[3]	OUTB1+	INB1-	V _{CC}	OUTB2+	INB2-	NC	NC	OUTA1+	INA1-	V _{CC}	OUTA2+	INA2-	TDO	B
BOE[2]	SDASEL	V _{CC}	RFMODE	PARCTL	SPDSEL	GND	GND	RXRATE	RXLE	LPEN	V _{CC}	RFEN	NC	C
V _{CC}	V _{CC}	INSELA	INSELB	TDI	TCLK	GND	GND	RXMODE[0]	RXMODE[1]	TXRATE	NC	V _{CC}	V _{CC}	D
TMS	$\overline{\text{TRSTZ}}$	RXCKSEL	TXCKSEL	TXPERB	TXOPB	GND	GND	BOE[1]	BOE[0]	TXMODE[0]	TXMODE[1]	FRAMCHAR	BISTLE	E
TXDB[0]	TXDB[1]	TXDB[2]	TXDB[3]	TXDB[4]	GND	GND	GND	GND	RXSTA[1]	RXSTA[2]	RXCLKC+	OELE	DECMODE	F
V _{CC}	NC	GND	GND	GND	GND	GND	GND	GND	GND	GND	GND	NC	V _{CC}	G
V _{CC}	NC	GND	GND	GND	GND	GND	GND	GND	GND	GND	GND	NC	V _{CC}	H
TXDB[5]	TXDB[6]	TXDB[7]	TXCTB[1]	TXCTB[0]	GND	GND	GND	GND	RXDA[2]	RXDA[1]	RXDA[0]	RXOPA	RXSTA[0]	J
TXCLKB	$\overline{\text{LFIB}}$	RXCLKB-	RXCLKB+	RXOPB	NC	GND	GND	TXCLKA	TXDA[4]	RXDA[6]	RXDA[5]	RXDA[4]	RXDA[3]	K
V _{CC}	V _{CC}	RXDB[7]	RXSTB[1]	RXSTB[2]	SCSEL	GND	GND	TXOPA	TXDA[3]	$\overline{\text{LFIA}}$	RXDA[7]	V _{CC}	V _{CC}	L
RXDB[6]	RXDB[5]	V _{CC}	RXSTB[0]	NC	$\overline{\text{TXRST}}$	GND	GND	TXPERA	TXDA[2]	NC	V _{CC}	TXCTA[1]	RXCLKA-	M
RXDB[4]	RXDB[3]	RXDB[2]	V _{CC}	TXCLKO+	REFCLK-	NC	NC	NC	TXDA[1]	V _{CC}	TXDA[6]	TXCTA[0]	RXCLKA+	N
V _{CC}	RXDB[0]	RXDB[1]	V _{CC}	TXCLKO-	REFCLK+	V _{CC}	V _{CC}	NC	TXDA[0]	V _{CC}	TXDA[5]	TXDA[7]	V _{CC}	P

Pin Descriptions

CYP15G0201DXB Dual HOTLink II Transceiver

Pin Name	I/O Characteristics	Signal Description
Transmit Path Data Signals		
TXPERA TXPERB	LVTTL Output, changes relative to REFCLK [↑] [2]	<p>Transmit Path Parity Error. Active HIGH. Asserted (HIGH) if parity checking is enabled and a parity error is detected at the Encoder. This output is HIGH for one transmit character clock period to indicate detection of a parity error in the character presented to the Encoder.</p> <p>If a parity error is detected, the character in error is replaced with a C0.7 character to force a corresponding bad-character detection at the remote end of the link. This replacement takes place regardless of the encoded/non-encoded state of the interface.</p> <p>When BIST is enabled for the specific transmit channel, BIST progress is presented on these outputs. Once every 511 character times (plus a 16-character Word Sync Sequence when the receive channels are clocked by a common clock, that is, RXCKSEL = LOW or HIGH), the associated TXPERx signal pulses HIGH for one transmit-character clock period (if RXCKSEL = MID) or seventeen transmit-character clock periods (if RXCKSEL = LOW or HIGH) to indicate a complete pass through the BIST sequence. For RXCKSEL = LOW or HIGH, if TXMODE[1:0] = LL, then no Word Sync Sequence is sent in BIST, and TXPERx pulses HIGH for one transmit-character clock period.</p> <p>These outputs also provide indication of a transmit Phase-Align Buffer underflow or overflow. When the transmit Phase-Align Buffers are enabled (TXCKSEL ≠ LOW, or TXCKSEL = LOW and TXRATE = HIGH), if an underflow or overflow condition is detected, TXPERx for the channel in error is asserted and remains asserted until either an atomic word sync sequence is transmitted or TXRST is sampled LOW to re-center the transmit phase-align buffers.</p>
TXCTA[1:0] TXCTB[1:0]	LVTTL Input, synchronous, sampled by the selected TXCLKx [↑] or REFCLK [↑] [2]	<p>Transmit Control. These inputs are captured on the rising edge of the transmit interface clock as selected by TXCKSEL, and are passed to the Encoder or Transmit Shifter. They identify how the associated TXDx[7:0] characters are interpreted. When the Encoder is bypassed, these inputs are interpreted as data bits. When the Encoder is enabled, these inputs determine if the TXDx[7:0] character is encoded as Data, a Special Character code, or replaced with other Special Character codes. See Table 1 on page 13 for details.</p>
TXDA[7:0] TXDB[7:0]	LVTTL Input, synchronous, sampled by the selected TXCLKx [↑] or REFCLK [↑] [2]	<p>Transmit Data Inputs. These inputs are captured on the rising edge of the transmit interface clock (selected by TXCKSEL) and passed to the Encoder or Transmit Shifter.</p> <p>When the Encoder is enabled (TXMODE[1:0] ≠ LL), TXDx[7:0] specify the specific data or command character to be sent.</p> <p>When the Encoder is bypassed, these inputs are interpreted as data bits of the 10-bit input character. See Table 1 on page 13 for details.</p>
$\overline{\text{TXRST}}$	LVTTL Input, asynchronous, internal pull-up, REFCLK [↑] [2]	<p>Transmit Clock Phase Reset. Transmit Clock Phase Reset. Active LOW. When sampled LOW, the transmit Phase-align Buffers are allowed to adjust their data-transfer timing (relative to the selected input clock) to allow clean transfer of data from the Input Register to the Encoder or Transmit Shifter. When TXRST is sampled HIGH, the internal phase relationship between the associated TXCLKx and the internal character-rate clock is fixed and the device operates normally.</p> <p>When configured for half-rate REFCLK sampling of the transmit character stream (TXCKSEL = LOW and TXRATE = HIGH), assertion of $\overline{\text{TXRST}}$ is only used to clear Phase-align buffer faults caused by highly asymmetric REFCLK periods or REFCLKs with excessive cycle-to-cycle jitter. During this alignment period, one or more characters may be added to or lost from all the associated transmit paths as the transmit Phase-align Buffers are adjusted. TXRST must be sampled LOW by a minimum of two consecutive rising edges of REFCLK to ensure the reset operation is initiated correctly on all channels. This input is ignored when both TXCKSEL and TXRATE are LOW, since the phase align buffer is bypassed. In all other configurations, TXRST should be asserted during device initialization to ensure proper operation of the Phase-align buffer. TXRST should be asserted after presence of a valid TXCLKx and after allowing enough time for the TXPLL to lock to the reference clock (as specified by parameter t_{TXLOCK}).</p>

Note

2. When REFCLK is configured for half-rate operation (TXRATE = HIGH), these inputs are sampled (or the outputs change) relative to both the rising and falling edges of REFCLK.

Pin Descriptions (continued)

CYP15G0201DXB Dual HOTLink II Transceiver

Pin Name	I/O Characteristics	Signal Description
SCSEL	LVTTL Input, synchronous, internal pull-down, sampled by TXCLKA↑ or REFCLK↑ [2]	Special Character Select. Used in some transmit modes along with TXCTx[1:0] to encode special characters or to initiate a Word Sync Sequence. When the transmit paths are configured for independent inputs clocks (TXCKSEL = MID), SCSEL is captured relative to TXCLKA↑.
TXOPA TXOPB	LVTTL Input, synchronous, internal pull-up, sampled by the respective TXCLKx↑ or REFCLK↑ [2]	Transmit Path Odd Parity. When parity checking is enabled (PARCTL ≠ LOW), the parity captured at these inputs is XORed with the data on the associated transmit data TXDx bus to verify the integrity of the captured character.
Transmit Path Clock and Clock Control		
TXCKSEL	3-Level Select ^[3] Static Control Input	Transmit Clock Select. Selects the clock source, used to write data into the Transmit Input Register, of the transmit channel(s). When LOW, both Input Registers are clocked by REFCLK↑ [2]. When MID, TXCLKx↑ is used as the Input Register clock for TXDx[7:0] and TXCTx[1:0]. When HIGH, TXCLKA↑ is used to clock data into the Input Register of each channel. When TXCKSEL = MID or HIGH (TXCLKx or TXCLKA selected to clock input register), configuring TXRATE = HIGH (Half-rate REFCLK) is an invalid mode of operation.
TXRATE	LVTTL Input, Static Control input, internal pull-down	Transmit PLL Clock Rate Select. When TXRATE = HIGH, the Transmit PLL multiplies REFCLK by 20 to generate the serial symbol-rate clock. When TXRATE = LOW, the transmit PLL multiplies REFCLK by 10 to generate the serial symbol-rate clock. See Table 10 on page 19 for a list of operating serial rates. When REFCLK is selected to clock the receive parallel interfaces (RXCKSEL = LOW), the TXRATE input also determines if the clocks on the RXCLKA± and RXCLKC± outputs are full or half-rate. When TXRATE = HIGH (REFCLK is half-rate), the RXCLKA± and RXCLKC± output clocks are also half-rate clocks and follow the frequency and duty cycle of the REFCLK input. When TXRATE = LOW (REFCLK is full-rate), the RXCLKA± and RXCLKC± output clocks are full-rate clocks and follow the frequency and duty cycle of the REFCLK input. When TXCKSEL = MID or HIGH (TXCLKx or TXCLKA selected to clock input register), configuring TXRATE = HIGH (Half-rate REFCLK) is an invalid mode of operation.
TXCLKO±	LVTTL Output	Transmit Clock Output. This true and complement output clock is synthesized by the transmit PLL and operates synchronous to the internal transmit character clock. It operates at either the same frequency as REFCLK (when TXRATE = LOW), or at twice the frequency of REFCLK (when TXRATE = HIGH). This output clock has no direct phase relationship to REFCLK.
TXCLKA TXCLKB	LVTTL Clock Input, internal pull-down	Transmit Path Input Clocks. These clocks must be frequency-coherent to TXCLKO±, but may be offset in phase. The internal operating phase of each input clock (relative to REFCLK or TXCLKO±) is adjusted when TXRST = LOW and locked when TXRST = HIGH.
Transmit Path Mode Control		
TXMODE[1:0]	3-Level Select ^[3] Static Control inputs	Transmit Operating Mode. These inputs are interpreted to select one of nine operating modes of the transmit path. See Table 3 on page 15 for a list of operating modes.

Note

3. 3-Level select inputs are used for static configuration. They are ternary (not binary) inputs that make use of non-standard logic levels of LOW, MID, and HIGH. The LOW level is usually implemented by direct connection to V_{SS} (ground). The HIGH level is usually implemented by direct connection to V_{CC} (power). When not connected or allowed to float, a 3-Level select input self-biases to the MID level.

Pin Descriptions (continued)

CYP15G0201DXB Dual HOTLink II Transceiver

Pin Name	I/O Characteristics	Signal Description
Receive Path Data Signals		
RXDA[7:0] RXDB[7:0]	LVTTL Output, synchronous to the selected RXCLKx [↑] output or REFCLK [↑] [2] input	<p>Parallel Data Output. These outputs change following the rising edge of the selected receive interface clock.</p> <p>When the Decoder is enabled (DECMODE = HIGH or MID), these outputs represent either received data or special characters. The status of the received data is represented by the values of RXSTx[2:0]. When the Decoder is bypassed (DECMODE = LOW), RXDx[7:0] become the higher order bits of the 10-bit received character. See Table 16 on page 25 for details.</p>
RXSTA[2:0] RXSTB[2:0]	LVTTL Output, synchronous to the selected RXCLKx [↑] output or REFCLK [↑] [2] input	<p>Parallel Status Output. These outputs change following the rising edge of the selected receive interface clock.</p> <p>When the Decoder is bypassed (DECMODE = LOW), RXSTx[1:0] become the two low-order bits of the 10-bit received character, while RXSTx[2] = HIGH indicates the presence of a Comma character in the Output Register. See Table 16 on page 25 for details.</p> <p>When the Decoder is enabled (DECMODE = HIGH or MID), RXSTx[2:0] provide status of the received signal. See Table 18 on page 27, Table 19 and Table 20 on page 30 for a list of Receive Character status.</p>
RXOPA RXOPB	3-state, LVTTL Output, synchronous to the selected RXCLKx [↑] output or REFCLK [↑] [2] input	<p>Receive Path Odd Parity. When parity generation is enabled (PARCTL ≠ LOW), the parity output at these pins is valid for the data on the associated RXDx bus bits. When parity generation is disabled (PARCTL = LOW) these output drivers are disabled (High-Z).</p>
Receive Path Clock and Clock Control		
RXRATE	LVTTL Input Static Control Input, internal pull-down	<p>Receive Clock Rate Select. When LOW, the RXCLKx[±] recovered clock outputs are complementary clocks operating at the recovered character rate. Data for the associated receive channels should be latched on the rising edge of RXCLKx⁺ or falling edge of RXCLKx⁻. When HIGH, the RXCLKx[±] recovered clock outputs are complementary clocks operating at half the character rate. Data for the associated receive channels should be latched alternately on the rising edge of RXCLKx⁺ and RXCLKx⁻.</p> <p>When REFCLK[±] is selected to clock the output registers (RXCKSEL = LOW), RXRATE_x is not interpreted. The RXCLKA[±] and RXCLKC[±] output clocks follow the frequency and duty cycle of REFCLK[±].</p>
RXCLKA [±] RXCLKB [±]	Three-state, LVTTL Output clock or Static control input	<p>Receive Character Clock Output or Clock Select Input. When configured such that all output data paths are clocked by the recovered clock (RXCKSEL = MID), these true and complement clocks are the receive interface clocks which are used to control timing of output data (RXDx[7:0], RXSTx[2:0] and RXOPx). These clocks are output continuously at either the dual-character rate (1/20th the serial symbol-rate) or character rate (1/10th the serial symbol-rate) of the data being received, as selected by RXRATE.</p> <p>When configured such that all output data paths are clocked by REFCLK instead of a recovered clock (RXCKSEL = LOW), the RXCLKA[±] and RXCLKC⁺ output drivers present a buffered and delayed form of REFCLK. RXCLKA[±] and RXCLKC⁺ are buffered forms of REFCLK that are slightly different in phase. This phase difference allows the user to select the optimal setup/hold timing for their specific interface.</p> <p>When RXCKSEL = HIGH and dual-channel bonding is enabled, one of the recovered clocks from channels A or B is selected to present bonded data from channels A and B. RXCLKA[±] output the recovered clock from either receive channel A or receive channel B as selected by RXCLKB⁺ to clock the bonded output data from channels A and B. See Table 14 on page 24 for details.</p> <p>When RXCKSEL = LOW and dual-channel bonding is enabled, REFCLK is selected to present bonded data from channels A and B. RXCLKA[±] and RXCLKC⁺ output drivers present a buffered and delayed form of REFCLK. The master channel for bonding is selected by RXCLKB⁺ (which acts as an input in this mode) to clock the bonded output data from channels A and B. See Table 14 on page 24 for details.</p>

Pin Descriptions (continued)

CYP15G0201DXB Dual HOTLink II Transceiver

Pin Name	I/O Characteristics	Signal Description
RXCKSEL	3-Level Select ^[3] Static Control Input	<p>Receive Clock Mode. Selects the receive clock-source used to transfer data to the output registers.</p> <p>When LOW, both Output Registers are clocked by REFCLK. RXCLKB± outputs are disabled (High-Z), and RXCLKA± and RXCLKC+ present buffered and delayed forms of REFCLK.</p> <p>When MID, each RXCLKx± output follows the recovered clock for the respective channel, as selected by RXRATE. When the 8B/10B Decoder and Elasticity Buffer are bypassed (DECMODE = LOW), RXCKSEL must be MID.</p> <p>When HIGH, and channel bonding is enabled in dual-channel mode (RX modes 2 and 3), RXCLKA± outputs the recovered clock from either receive channel A or receive channel B as selected by RXCLKB+. These output clocks may operate at the character-rate or half the character-rate as selected by RXRATE.</p>
DECMODE	3-Level Select ^[3] Static Control Input	<p>Decoder Mode Select. This input selects the behavior of the Decoder block.</p> <p>When LOW, the Decoder is bypassed and raw 10-bit characters are passed to the Output Register. When the Decoder is bypassed, RXCKSEL must be MID.</p> <p>When MID, the Decoder is enabled and the Cypress decoder table for Special Code characters is used. When HIGH, the Decoder is enabled and the alternate Decoder table for Special Code characters is used. See Table 25 on page 47 for a list of the Special Codes supported in both encoded modes.</p>
RXMODE[1:0]	3-Level Select ^[3] Static Control Inputs	<p>Receive Operating Mode. These inputs are interpreted to select one of nine operating modes of the receive path. See Table 13 on page 23 for details.</p>
RFEN	LVTTL input, asynchronous, internal pull-down	<p>Reframe Enable for All Channels. Active HIGH. When HIGH, the framers in both channels are enabled to frame per the presently enabled framing mode and selected framing character.</p>
RFMODE	3-Level Select ^[3] Static Control Input	<p>Reframe Mode Select. Used to control the type of character framing used to adjust the character boundaries (based on detection of one or more framing characters in the received serial bit stream). This signal operates in conjunction with the presently enabled channel bonding mode, and the type of framing character selected.</p> <p>When LOW, the low-latency framer is selected. This frames on each occurrence of the selected framing character(s) in the received data stream. This mode of framing stretches the recovered clock for one or multiple cycles to align that clock with the recovered data.</p> <p>When MID, the Cypress-mode multi-byte parallel framer is selected. This requires a pair of the selected framing character(s), on identical 10-bit boundaries, within a span of 50 bits, before the character boundaries are adjusted. The recovered character clock remains in the same phasing regardless of character offset.</p> <p>When HIGH, the alternate mode multi-byte parallel framer is selected. This requires detection of the selected framing character(s) of the allowed disparities in the received serial bit stream, on identical 10-bit boundaries, on four directly adjacent characters. The recovered character clock remains in the same phasing regardless of character offset.</p>
FRAMCHAR	3-Level Select ^[3] Static Control Input	<p>Framing Character Select. Used to control the character or portion of a character used for character framing of the received data streams.</p> <p>When MID, the framer looks for both positive and negative disparity versions of the 8-bit Comma character. When HIGH, the framer looks for both positive and negative disparity versions of the K28.5 character. Configuring FRAMCHAR to LOW is reserved for component test.</p>

Pin Descriptions (continued)

CYP15G0201DXB Dual HOTLink II Transceiver

Pin Name	I/O Characteristics	Signal Description
Device Control Signals		
PARCTL	3-Level Select ^[3] Static Control Input	<p>Parity Check/Generate Control. Used to control the different parity check and generate functions.</p> <p>When LOW, parity checking is disabled, and the RXOPx outputs are all disabled (High-Z). When MID, and the Encoder/Decoder are enabled (TXMODE[1] ≠ LOW, DECMODE ≠ LOW), TXDx[7:0] inputs are checked (along with TXOPx) for valid ODD parity, and ODD parity is generated for the RXDx[7:0] outputs and presented on RXOPx. When the Encoder and Decoder are disabled (TXMODE[1] = LOW, DECMODE = LOW), the TXDx[7:0] and TXCTx[1:0] inputs are checked (along with TXOPx) for valid ODD parity, and ODD parity is generated for the RXDx[7:0] and RXSTx[1:0] outputs and presented on RXOPx. When HIGH, parity checking and generation are enabled. The TXDx[7:0] and TXCTx[1:0] inputs are checked (along with TXOPx) for valid ODD parity, and ODD parity is generated for the RXDx[7:0] and RXSTx[2:0] outputs and presented on RXOPx.</p>
REFCLK±	Differential LVPECL or single-ended LVTTTL input clock	<p>Reference Clock. This clock input is used as the timing reference for the transmit and receive PLLs. This input clock may also be selected to clock the transmit and receive parallel interfaces. When driven by a single-ended LVCMOS or LVTTTL clock source, connect the clock source to either the true or complement REFCLK input, and leave the alternate REFCLK input open (floating). When driven by an LVPECL clock source, the clock must be a differential clock, using both inputs. When TXCKSEL = LOW, REFCLK is also used as the clock for the parallel transmit data (input) interface. When RXCKSEL = LOW, the Elasticity Buffer is enabled and REFCLK is used as the clock for the parallel receive data (output) interface.</p> <p>If the Elasticity Buffer is used, then the framing characters are inserted or deleted to/from the data stream to compensate frequency differences between the reference clock and recovered clock. When addition happens, a K28.5 is appended immediately after a framing character is detected in the elasticity buffer. When deletion happens, a framing character is removed from the datastream when detected in the elasticity buffer.</p>
RXCLKC+	3-state LVTTTL Output	<p>Delayed REFCLK+ when RXCKSEL = LOW. Delayed form of REFCLK+, used for transfer of recovered data to a host system. This output is only enabled when the receive parallel interface is configured to present data relative to REFCLK (RXCKSEL = LOW).</p>
SPDSEL	3-Level Select ^[3] , static control input	<p>Serial Rate Select. This input specifies the operating bit-rate range of both transmit and receive PLLs. LOW = 195 to 400 MBd, MID = 400 to 800 MBd, HIGH = 800 to 1500 MBd (800–1540 MBd for CYW15G0201DXB). When SPDSEL is LOW, setting TXRATE = HIGH (Half-rate Reference Clock) is invalid.</p>
TRSTZ	LVTTTL Input, internal pull-up	<p>Device Reset. Active LOW. Initializes all state machines and counters in the device.</p> <p>When sampled LOW by the rising edge of REFCLK, this input resets the internal state machines and sets the Elasticity Buffer pointers to a nominal offset. When the reset is removed (TRSTZ sampled HIGH by REFCLK↑), the status and data outputs become deterministic in less than 16 REFCLK cycles.</p> <p>The BISTLE, OELE, and RXLE latches are reset by TRSTZ.</p> <p>If the Elasticity Buffer or the Phase Align Buffer are used, TRSTZ should be applied after power-up to initialize the internal pointers into these memory arrays.</p>
Analog I/O and Control		
OUTA1± OUTB1±	CML Differential Output	<p>Primary Differential Serial Data Outputs. These PECL-compatible CML outputs (+3.3 V referenced) are capable of driving terminated transmission lines or standard fiber-optic transmitter modules.</p>
OUTA2± OUTB2±	CML Differential Output	<p>Secondary Differential Serial Data Outputs. These PECL-compatible CML outputs (+3.3 V referenced) are capable of driving terminated transmission lines or standard fiber-optic transmitter modules.</p>
INA1± INB1±	LVPECL Differential Input	<p>Primary Differential Serial Data Inputs. These inputs accept the serial data stream for deserialization and decoding. The INx1± serial streams are passed to the receiver Clock and Data Recovery (CDR) circuits to extract the data content when INSELx = HIGH.</p>

Pin Descriptions (continued)

CYP15G0201DXB Dual HOTLink II Transceiver

Pin Name	I/O Characteristics	Signal Description
INA2± INB2±	LVPECL Differential Input	Secondary Differential Serial Data Inputs. These inputs accept the serial data stream for deserialization and decoding. The INx2± serial streams are passed to the receiver Clock and Data Recovery (CDR) circuits to extract the data content when INSELx = LOW.
INSELA INSELB	LVTTTL Input, asynchronous	Receive Input Selector. Determines which external serial bit stream is passed to the receiver Clock and Data Recovery circuit. When HIGH, the INx1± input is selected. When LOW, the INx2± input is selected.
SDASEL	3-Level Select ^[3] , static configuration input	Signal Detect Amplitude Level Select. Allows selection of one of three predefined amplitude trip points for a valid signal indication, as listed in Table 11 on page 20 .
LPEN	LVTTTL Input, asynchronous, internal pull-down	All-Port Loop-Back-Enable. Active HIGH. When asserted (HIGH), the transmit serial data from each channel is internally routed to the associated receiver Clock and Data Recovery (CDR) circuit. All serial drivers are forced to differential logic "1". All serial data inputs are ignored.
OELE	LVTTTL Input, asynchronous, internal pull-up	Serial Driver Output Enable Latch Enable. Active HIGH. When OELE = HIGH, the signals on the BOE[3:0] inputs directly control the OUTxy± differential drivers. When the BOE[x] input is HIGH, the associated OUTxy± differential driver is enabled. When the BOE[x] input is LOW, the associated OUTxy± differential driver is powered down. When OELE returns LOW, the last values present on BOE[3:0] are captured in the internal Output Enable Latch. The specific mapping of BOE[3:0] signals to transmit output enables is listed in Table 9 on page 18 . If the device is reset ($\overline{\text{TRSTZ}}$ is sampled LOW), the latch is reset to disable all outputs.
RXLE	LVTTTL Input, asynchronous, internal pull-up	Receive Channel Power-Control Latch Enable. Active HIGH. When RXLE = HIGH, the signals on the BOE[3:0] inputs directly control the power enables for the receive PLLs and analog logic. When the BOE[3:0] input is HIGH, the associated receive channel A and receive channel B PLL and analog logic are active. When the BOE[3:0] input is LOW, the associated receive channel A and receive channel B PLL and analog logic are placed in a non-functional power saving mode. When RXLE returns LOW, the last values present on BOE[3:0] are captured in the internal RX PLL Enable Latch. The specific mapping of BOE[3:0] signals to the associated receive channel enables is listed in Table 9 on page 18 . When the device is reset ($\overline{\text{TRSTZ}}$ is sampled LOW), the latch is reset to disable both receive channels.
BISTLE	LVTTTL Input, asynchronous, internal pull-up	Transmit and Receive BIST Latch Enable. Active HIGH. When BISTLE = HIGH, the signals on the BOE[3:0] inputs directly control the transmit and receive BIST enables. When the BOE[x] input is LOW, the associated transmit or receive channel is configured to generate or compare the BIST sequence. When the BOE[x] input is HIGH, the associated transmit or receive channel is configured for normal data transmission or reception. When BISTLE returns LOW, the last values present on BOE[3:0] are captured in the internal BIST Enable Latch. The specific mapping of BOE[3:0] signals to transmit and receive BIST enables is listed in Table 9 on page 18 . When the latch is closed, if the device is reset ($\overline{\text{TRSTZ}}$ is sampled LOW), the latch is reset to disable BIST on all transmit and receive channels.
BOE[3:0]	LVTTTL Input, asynchronous, internal pull-up	BIST, Serial Output, and Receive Channel Enables. These inputs are passed to and through the Output Enable Latch when OELE = HIGH, and captured in this latch when OELE returns LOW. These inputs are passed to and through the BIST Enable Latch when BISTLE = HIGH, and captured in this latch when BISTLE returns LOW. These inputs are passed to and through the Receive Channel Enable Latch when RXLE = HIGH, and captured in this latch when RXLE returns LOW.
$\overline{\text{LFIA}}$ LFIB	LVTTTL Output, Asynchronous	Link Fault Indication Output. Active LOW. LFIx is the logical OR of four internal conditions: <ol style="list-style-type: none"> 1. Received serial data frequency outside expected range. 2. Analog amplitude below expected levels. 3. Transition density lower than expected. 4. Receive Channel disabled.

Pin Descriptions (continued)

CYP15G0201DXB Dual HOTLink II Transceiver

Pin Name	I/O Characteristics	Signal Description
JTAG Interface		
TMS	LVTTTL Input, internal pull-up	Test Mode Select. Used to control access to the JTAG Test Modes. If maintained HIGH for >5 TCLK cycles, the JTAG test controller is reset. The TAP controller is also reset automatically upon application of power to the device.
TCLK	LVTTTL Input, internal pull-down	JTAG Test Clock.
TDO	3-State LVTTTL Output	Test Data Out. JTAG data output buffer which is High-Z while JTAG test mode is not selected.
TDI	LVTTTL Input, internal pull-up	Test Data In. JTAG data input port.
Power		
V _{CC}		+3.3 V power.
GND		Signal and Power Ground for all internal circuits.

CYP15G0201DXB HOTLink II Operation

The CYP15G0201DXB is a highly configurable device designed to support reliable transfer of large quantities of data, using high-speed serial links, from one or multiple sources to one or multiple destinations. This device supports two single-byte or single-character channels that may be combined to support transfer of wider buses.

CYP15G0201DXB Transmit Data Path

Operating Modes

The transmit path of the CYP15G0201DXB supports two character-wide data paths. These data paths are used in multiple operating modes as controlled by the TXMODE[1:0] inputs.

Input Register

The bits in the input register for each channel support different assignments, based on if the character is unencoded, encoded with two control bits, or encoded with three control bits. These assignments are shown in Table 1.

Each input register captures a minimum of eight data bits and two control bits on each input clock cycle. When the Encoder is bypassed, the TXCTx[1:0] control bits are part of the pre-encoded 10-bit character.

When the encoder is enabled (TXMODE[1] ≠ LOW), the TXCTx[1:0] bits are interpreted along with the associated TXDx[7:0] character to generate the specific 10-bit transmission character. When TXMODE[0] ≠ HIGH, an additional special character select (SCSEL) input is also captured and interpreted. This SCSEL input is used to modify the encoding of the associated characters. When the transmit input registers are clocked by a common clock (TXCLKA↑ or REFCLK↑), this SCSEL input can be changed on a clock-by-clock basis and affects both channels.

Table 1. Input Register Bit Assignments^[4]

Signal Name	Unencoded	Encoded	
		2-bit Control	3-bit Control
TXDx[0] (LSB)	DINx[0]	TXDx[0]	TXDx[0]
TXDx[1]	DINx[1]	TXDx[1]	TXDx[1]
TXDx[2]	DINx[2]	TXDx[2]	TXDx[2]
TXDx[3]	DINx[3]	TXDx[3]	TXDx[3]
TXDx[4]	DINx[4]	TXDx[4]	TXDx[4]
TXDx[5]	DINx[5]	TXDx[5]	TXDx[5]
TXDx[6]	DINx[6]	TXDx[6]	TXDx[6]
TXDx[7]	DINx[7]	TXDx[7]	TXDx[7]
TXCTx[0]	DINx[8]	TXCTx[0]	TXCTx[0]
TXCTx[1] (MSB)	DINx[9]	TXCTx[1]	TXCTx[1]
SCSEL	N/A	N/A	SCSEL

Notes

- The TXOPx inputs are also captured in the associated Input Register, but their interpretation is under the separate control of PARCTL.
- One or more K28.5 characters may be added or lost from the data stream during this reset operation. When used with non-Cypress devices that require a complete 16-character word sync sequence for proper receive elasticity buffer alignment, it is recommend that the sequence be followed by a second word sync sequence to ensure proper operation.

When operated with a separate input clock on each transmit channel, this SCSEL input is sampled synchronous to TXCLKA↑. While the value on SCSEL still affects both channels, it is interpreted when the character containing it is read from the transmit phase-align buffer (where both paths are internally clocked synchronously).

Phase-Align Buffer

Data from the input registers is passed either to the encoder or to the associated phase-align buffer. When the transmit paths are operated synchronous to REFCLK↑ (TXCKSEL = LOW and TXRATE = LOW), the phase-align buffers are bypassed and data is passed directly to the parity check and Encoder blocks to reduce latency.

When an Input-Register clock with an uncontrolled phase relationship to REFCLK is selected (TXCKSEL ≠ LOW) or if data is captured on both edges of REFCLK (TXRATE = HIGH), the phase-align buffers are enabled. These buffers are used to absorb clock phase differences between the presently selected input clock and the internal character clock.

Initialization of these phase-align buffers takes place when the TXRST input is sampled by two consecutive rising edges of REFCLK. When TXRST is returned HIGH, the present input clock phase relative to REFCLK↑ is set. TXRST is an asynchronous input, but is sampled internally to synchronize it to the internal transmit path state machines.

After set, the input clocks are allowed to skew in time up to half a character period in either direction relative to REFCLK↑; that is, ±180°. This time shift allows the delay paths of the character clocks (relative to REFCLK↑) to change due to operating voltage and temperature, while not affecting the design operation.

If the phase offset, between the initialized location of the input clock and REFCLK↑, exceeds the skew handling capabilities of the phase-align buffer, an error is reported on the associated TXPERx output. This output indicates a continuous error until the phase-align buffer is reset. While the error remains active, the transmitter for the associated channel outputs a continuous C0.7 character to indicate to the remote receiver that an error condition is present in the link.

In specific transmit modes, it is also possible to reset the phase-align buffers individually and with minimal disruption of the serial data stream. When the transmit interface is configured for generation of atomic word sync sequences (TXMODE[1] = MID) and a phase-align buffer error is present, the transmission of a word sync sequence recenters the phase align buffer and clears the error condition.^[5]

Parity Support

In addition to the ten data and control bits that are captured at each transmit input register, a TXOPx input is also available on each channel. This allows the CYP15G0201DXB to support ODD parity checking for each channel. This parity checking is available for all operating modes (including encoder bypass). The specific mode of parity checking is controlled by the PARCTL input, and operates per [Table 2](#).

Table 2. Input Register Bits Checked for Parity^[6]

Signal Name	Transmit Parity Check Mode (PARCTL)			
	LOW	MID		HIGH
		TXMODE[1] = LOW	TXMODE[1] ≠ LOW	
TXDx[0]		X ^[7]	X	X
TXDx[1]		X	X	X
TXDx[2]		X	X	X
TXDx[3]		X	X	X
TXDx[4]		X	X	X
TXDx[5]		X	X	X
TXDx[6]		X	X	X
TXDx[7]		X	X	X
TXCTX[0]		X		X
TXCTX[1]		X		X
TXOPx		X	X	X

When PARCTL is MID (open) and the encoders are enabled (TXMODE[1] ≠ L), only the TXDx[7:0] data bits are checked for ODD parity along with the associated TXOPx bit. When PARCTL = HIGH with the Encoder enabled (or MID with the encoder bypassed), the TXDx[7:0] and TXCTX[1:0] inputs are checked for ODD parity along with the associated TXOPx bit. When PARCTL = LOW, parity checking is disabled.

When parity checking and the encoder are both enabled (TXMODE[1] ≠ LOW), the detection of a parity error causes a C0.7 character of proper disparity to be passed to the transmit shifter. When the encoder is bypassed (TXMODE[1] = LOW), detection of a parity error causes a positive disparity version of a C0.7 transmission character to be passed to the transmit shifter.

Encoder

The character, received from the input register or phase-align buffer and parity check logic, is then passed to the encoder logic. This block interprets each character and any associated control bits, and outputs a 10-bit transmission character.

Depending on the configured operating mode, the generated transmission character may be,

- The 10-bit pre-encoded character accepted in the input register
- The 10-bit equivalent of the 8-bit data character accepted in the input register

Notes

6. Transmit path parity errors are reported on the associated TXPERx output.
7. Bits marked as X are XORed together. Result must be a logic-1 for parity to be valid.

- The 10-bit equivalent of the 8-bit special character code accepted in the Input Register
- The 10-bit equivalent of the C0.7 SVS character if parity checking was enabled and a parity error was detected
- The 10-bit equivalent of the C0.7 SVS character if a Phase-Align Buffer overflow or underflow error is present
- A character that is part of the 511-character BIST sequence
- A K28.5 character generated as an individual character or as part of the 16-character Word Sync Sequence.

The selection of the specific characters generated is controlled by the TXMODE[1:0], SCSEL, TXCTX[1:0], and TXDx[7:0] inputs for each character.

Data Encoding

Raw data, as received directly from the Transmit Input Register, is seldom in a form suitable for transmission across a serial link. The characters must usually be processed or transformed to guarantee

- A minimum transition density (to allow the serial receive PLL to extract a clock from the data stream)
- A DC-balance in the signaling (to prevent baseline wander)
- Run-length limits in the serial data (to limit the bandwidth requirements of the serial link)
- The remote receiver a way of determining the correct character boundaries (framing)

When the encoder is enabled (TXMODE[1] ≠ LOW), the characters to be transmitted are converted from data or special character codes to 10-bit transmission characters (as selected by their respective TXCTX[1:0] and SCSEL inputs), using an integrated 8B/10B encoder. When directed to encode that is, the character as a special character code, it is encoded using the special character encoding rules listed in [Table 25 on page 47](#). When directed to encode the character as a data character, it is encoded using the data character encoding rules in [Table 24 on page 43](#).

The 8B/10B Encoder is standards compliant with ANSI/NCITS ASC X3.230-1994 (Fibre Channel), IEEE 802.3z (Gigabit Ethernet), the IBM[®] ESCON[®] and FICON[®] channels, and Digital Video Broadcast DVB-ASI standards for data transport.

Many of the Special Character codes listed in [Table 25 on page 47](#) may be generated by more than one input character. The CYP15G0201DXB is designed to support two independent (but non-overlapping) Special Character code tables. This allows the CYP15G0201DXB to operate in mixed environments with other CYP15G0201DXBs using the enhanced Cypress command code set, and the reduced command sets of other non-Cypress devices. Even when used in an environment that normally uses non-Cypress Special Character codes, the selective use of Cypress command codes can permit operation where running disparity and error handling must be managed.

Following conversion of each input character from eight bits to a 10-bit transmission character, it is passed to the Transmit Shifter and is shifted out LSB first, as required by ANSI and IEEE standards for 8B/10B coded serial data streams.

Transmit Modes

The operating mode of the transmit path is set through the TXMODE[1:0] inputs. These 3-level select inputs allow one of nine transmit modes to be selected. The transmit modes are listed in Table 3.

The encoded modes (TX Modes 3 through 8) support multiple encoding tables. These encoding tables vary by the specific combinations of SCSEL, TXCTx[1], and TXCTx[0] that are used to control the generation of data and control characters. These multiple encoding forms allow maximum flexibility in interfacing to legacy applications, while also supporting numerous extensions in capabilities.

Table 3. Transmit Operating Modes

TX Mode		Operating Mode		
Mode Number	TXMODE [1:0]	Word Sync Sequence Support	SCSEL Control	TXCTx Function
0	LL	None	None	Encoder Bypass
1	LM	None	None	Reserved for test
2	LH	None	None	Reserved for test
3	ML	Atomic	Special character	Encoder Control
4	MM	Atomic	Word Sync	Encoder Control
5	MH	Atomic	None	Encoder Control
6	HL	Interruptible	Special character	Encoder Control
7	HM	Interruptible	Word sync	Encoder Control
8	HH	Interruptible	None	Encoder Control

TX Mode 0—Encoder Bypass

When the Encoder is bypassed, the character captured in the TXDx[7:0] and TXCTx[1:0] inputs is passed directly to the Transmit Shifter without modification. If parity checking is enabled (PARCTL ≠ LOW) and a parity error is detected, the 10-bit character is replaced with the 1001111000 pattern (+C0.7 character).

With the Encoder bypassed, the TXCTx[1:0] inputs are considered part of the data character and do not perform a control function that would otherwise modify the interpretation of the TXDx[7:0] bits. The bit usage and mapping of these control bits when the Encoder is bypassed is shown in Table 4.

Table 4. Encoder Bypass Mode (TXMODE[1:0] = LL)

Signal Name	Bus Weight	10B Name
TXDx[0] (LSb) ^{8]}	2 ⁰	a
TXDx[1]	2 ¹	b
TXDx[2]	2 ²	c
TXDx[3]	2 ³	d
TXDx[4]	2 ⁴	e
TXDx[5]	2 ⁵	i
TXDx[6]	2 ⁶	f
TXDx[7]	2 ⁷	g
TXCTx[0]	2 ⁸	h
TXCTx[1] (MSb)	2 ⁹	j

TX Modes 1 and 2—Factory Test Modes

In Encoder Bypass the SCSEL input is ignored. All clocking modes interpret the data the same, with no internal linking between channels.

These modes enable specific factory test configurations. They are not considered normal operating modes of the device. Entry or configuration into these test modes do not damage the device.

Note

8. LSb is shifted out first.

TX Mode 3—Atomic Word Sync and SCSEL Control of Special Codes

When configured in TX Mode 3, the SCSEL input is captured along with the associated TXCTx[1:0] data control inputs. These bits combine to control the interpretation of the TXDx[7:0] bits and the characters generated by them. These bits are interpreted as listed in Table 5.

Table 5. TX Modes 3 and 6 Encoding

SCSEL	TXCTx[1]	TXCTx[0]	Characters Generated
X	X	0	Encoded data character
0	0	1	K28.5 fill character
1	0	1	Special character code
X	1	1	16-character word sync sequence

When TXCKSEL = MID, both transmit channels capture data into their Input Registers using independent TXCLKx clocks. The SCSEL input is sampled only by TXCLKA↑. When the character (accepted in the Channel-A Input Register) has passed through the Phase-Align Buffer and any selected parity validation, the level captured on SCSEL is passed to the Encoder of Channel-B during this same cycle.

To avoid the possible ambiguities that may arise due to the uncontrolled arrival of SCSEL relative to the characters in the alternate channel, SCSEL is often used as a static control input.

Word Sync Sequence

When TXCTx[1:0] = 11, a 16-character sequence of K28.5 characters, known as a word sync sequence, is generated on the associated channel. This sequence of K28.5 characters may start with either a positive or negative disparity K28.5 (as determined by the current running disparity and the 8B/10B coding rules). The disparity of the second and third K28.5 characters in this sequence are reversed from what normal 8B/10B coding rules would generate. The remaining K28.5 characters in the sequence follow all 8B/10B coding rules. The disparity of the generated K28.5 characters in this sequence would follow a pattern of either

+ + - - + - + - + - + - + - + - or
 - - + + - - + - + - + - + - + - + -

When TXMODE[1] = MID (open, TX modes 3, 4, and 5), the generation of this character sequence is an atomic (non-interruptible) operation. After it has been successfully started, it cannot be stopped until all 16 characters have been generated. The content of the associated Input Register(s) is ignored for the duration of this 16-character sequence.

At the end of this sequence, if the TXCTx[1:0] = 11 condition is sampled again, the sequence restarts and remains uninterruptible for the following 15 character clocks.

If parity checking is enabled, the character used to start the Word Sync Sequence must also have correct ODD parity. After the sequence is started, parity is not checked on the following 15 characters in the Word Sync Sequence.

When TXMODE[1] = HIGH (TX modes 6, 7, and 8), the generation of the word sync sequence becomes an interruptible operation. In TX Mode 6, this sequence is started as soon as the TXCTx[1:0] = 11 condition is detected on a channel. In order for the sequence to continue on that channel, the TXCTx[1:0] inputs must be sampled as 00 for the remaining 15 characters of the sequence.

If at any time a sample period exists where TXCTx[1:0] ≠ 00, the word sync sequence is terminated, and a character representing the associated data and control bits is generated by the Encoder. This resets the word sync sequence state machine such that it starts at the beginning of the sequence at the next occurrence of TXCTx[1:0] = 11.

When parity checking is enabled and TXMODE[1] = HIGH, all characters (including those in the middle of a word sync sequence) must have correct parity. The detection of a character with incorrect parity during a word sync sequence (regardless of the state of TXCTx[1:0]) interrupts that sequence and forces the generation of a C0.7 SVS character. Any interruption of the Word Sync Sequence causes the sequence to terminate.

When TXCKSEL = LOW, the Input Registers for both transmit channels are clocked by REFCLK^[2]. When TXCKSEL = HIGH, the Input Registers for both transmit channels are clocked with TXCLKA↑. In these clock modes both sets of TXCTx[1:0] inputs operate synchronous to the SCSEL input.^[9]

Note
 9. When operated in any condition where receive channels are bonded together, TXCKSEL must be either LOW or HIGH (not MID) to ensure that associated characters are transmitted in the same character cycle.

TX Mode 4—Atomic Word Sync and SCSEL Control of Word Sync Sequence Generation

When configured in TX Mode 4, the SCSEL input is captured along with the associated TXCTx[1:0] data control inputs. These bits combine to control the interpretation of the TXDx[7:0] bits and the characters generated by them. These bits are interpreted as listed in Table 6.

Table 6. TX Modes 4 and 7 Encoding

| SCSEL | TXCTx[1] | TXCTx[0] | Characters Generated |
|-------|----------|----------|---------------------------------|
| X | X | 0 | Encoded data character |
| 0 | 0 | 1 | K28.5 fill character |
| 0 | 1 | 1 | Special character code |
| 1 | X | 1 | 16-character Word Sync Sequence |

When TXCKSEL = MID, both transmit channels operate independently. The SCSEL input is sampled only by TXCLKA↑. When the character accepted in the Channel-A input register has passed any selected validation and is ready to be passed to the encoder, the level captured on SCSEL is passed to the Encoder of Channel-B during this same cycle.

Changing the state of SCSEL changes the relationship of the characters on the alternate channel. SCSEL should either be used as a static configuration input or changed only when the state of TXCTx[1:0] on the alternate channel are such that SCSEL is ignored during the change.

TX Mode 4 also supports an atomic word sync sequence. Unlike TX Mode 3, this sequence is started when both SCSEL and TXCTx[0] are sampled HIGH. With the exception of the combination of control bits used to initiate the sequence, the generation and operation of this word sync sequence is the same as that documented for TX Mode 3.

TX Mode 5—Atomic Word Sync, No SCSEL

When configured in TX Mode 5, the SCSEL signal is not used. In addition to the standard character encodings, both with and

without atomic word sync sequence generation, two additional encoding mappings are controlled by the channel bonding selection made through the RXMODE[1:0] inputs.

For non-bonded operation, the TXCTx[1:0] inputs for each channel control the characters generated by that channel. The specific characters generated by these bits are listed in Table 7 on page 17.

Table 7. TX Modes 5 and 8 Encoding, Non-Bonded (RXMODE[1] = LOW)

| SCSEL | TXCTx[1] | TXCTx[0] | Characters Generated |
|-------|----------|----------|---------------------------------|
| X | 0 | 0 | Encoded data character |
| X | 0 | 1 | K28.5 fill character |
| X | 1 | 0 | Special character code |
| X | 1 | 1 | 16-character Word Sync Sequence |

TX Mode 5 also has the capability of generating an atomic Word Sync Sequence. For the sequence to be started, the TXCTx[1:0] inputs must both be sampled HIGH. With the exception of the combination of control bits used to initiate the sequence, the generation and operation of this Word Sync Sequence is the same as that documented for TX Mode 3.

Two additional encoding maps are provided for use when receive channel bonding is enabled. When dual-channel bonding is enabled (RXMODE[1] = HIGH), the CYP15G0201DXB is configured such that channels A and B are bonded together to form a two-character-wide path.

When operated in this two-channel bonded mode, the TXCTA[0] and TXCTB[0] inputs control the interpretation of the data on both the A and B channels. The characters on each half of these bonded channels are controlled by the associated TXCTx[1] bit. The specific characters generated by these control bit combinations are listed in Table 8.

Table 8. TX Modes 5 and 8, Dual-channel Bonded (RXMODE[1] = HIGH)

| SCSEL | TXCTA[1] | TXCTA[0] | TXCTB[1] | TXCTB[0] | Characters Generated |
|-------|----------|----------|----------|----------|--|
| X | 0 | 0 | X | 0 | Encoded data character on channel A |
| X | 0 | 1 | X | 0 | K28.5 fill character on channel A |
| X | 1 | 0 | X | 0 | Special character code on channel A |
| X | 1 | 1 | X | 0 | 16-character word sync on channel A |
| X | X | 0 | 0 | 0 | Encoded data character on channel B |
| X | X | 1 | 0 | 0 | K28.5 fill character on channel B |
| X | X | 0 | 1 | 0 | Special character code on channel B |
| X | X | 1 | 1 | 0 | 16-character word sync on channel B |
| X | X | X | X | 1 | 16-character word sync on channels A and B |

Note especially that any time TXCTB[0] is sampled HIGH, both channels A and B start generating an Atomic Word Sync Sequence, regardless of the state of any of the other bits in the A or B Input Registers (with the exception of any enabled parity checking).

Transmit BIST

Each transmit channel contains an internal pattern generator that can be used to validate both device and link operation. These generators are enabled by the associated BOE[x] signals listed in Table 9 on page 18 (when the BISTLE latch enable input is HIGH). When enabled, a register in the associated transmit channel becomes a signature pattern generator by logically converting to a linear feedback shift register (LFSR). This LFSR generates a 511-character sequence that includes all Data and Special Character codes, including the explicit violation symbols. This provides a predictable yet pseudo-random sequence that can be matched to an identical LFSR in the attached receiver(s). If the receive channels are configured for common clock operation (RXCKSEL ≠ MID) and Encoder is enabled (TXMODE[1] ≠ LOW) each pass is preceded by a 16-character Word Sync Sequence to allow Elasticity Buffer alignment and management of clock- frequency variations.

When the BISTLE signal is HIGH, any BOE[x] input that is LOW enables the BIST generator in the associated transmit channel (or the BIST checker in the associated receive channel). When BISTLE returns LOW, the values of all BOE[x] signals are captured in the BIST Enable Latch. These values remain in the BIST Enable Latch until BISTLE is returned HIGH to open the latch. A device reset, (TRSTZ sampled LOW) presets the BIST Enable Latch to disable BIST on all channels. All data and data-control information present at the associated TXDx[7:0] and TXCTx[1:0] inputs are ignored when BIST is active on that channel.

Serial Output Drivers

The serial interface output drivers use high-performance differential current mode logic (CML) to provide a source-matched driver for the transmission lines. These drivers accept data from the transmit shifters. these outputs have signal swings equivalent to that of standard PECL drivers, and are capable of driving AC-coupled optical modules or transmission lines.

When configured for local loopback (LPEN = HIGH), all enabled Serial Drivers are configured to drive a static differential logic-1.

Each serial driver can be enabled or disabled separately through the BOE[3:0] inputs, as controlled by the OELE latch-enable signal. When OELE is HIGH, the signals present on the BOE[3:0] inputs are passed through the Serial Output Enable Latch to control the serial output drivers. The BOE[3:0] input associated with a specific OUTxy± driver is listed in Table 9.

Table 9. Output Enable, BIST, and Receive Channel Enable Signal Map

| BOE Input | Output Controlled (OELE) | BIST Channel Enable (BISTLE) | Receive PLL Channel Enable (RXLE) |
|-----------|--------------------------|------------------------------|-----------------------------------|
| BOE[3] | OUTB2± | Transmit B | X |
| BOE[2] | OUTB1± | Receive B | Receive B |
| BOE[1] | OUTA2± | Transmit A | X |
| BOE[0] | OUTA1± | Receive A | Receive A |

When OELE is HIGH and BOE[x] is HIGH, the associated serial driver is enabled. When OELE is HIGH and BOE[x] is LOW, the associated driver is disabled and internally powered down. If both outputs for a channel are in this disabled state, the associated internal logic for that channel is also powered down. When OELE returns LOW, the values present on the BOE[3:0] inputs are latched in the Output Enable Latch, and remain there until OELE returns HIGH to enable the latch. A device reset (TRSTZ sampled LOW) clears this latch and disables all output drivers.

Note. When all transmit channels are disabled (that is, both outputs disabled in all channels) and a channel is re-enabled, the data on the Serial Drivers may not meet all timing specifications for up to 200 μs.

Transmit PLL Clock Multiplier

The transmit PLL clock multiplier accepts a character-rate or half-character-rate external clock at the REFCLK input, and multiplies that clock by 10 or 20 (as selected by TXRATE) to generate a bit-rate clock for use by the Transmit Shifter. It also provides a character-rate clock used by the transmit paths.

The clock multiplier PLL can accept a REFCLK input between 10 MHz and 150 MHz, however, this clock range is limited by the operating mode of the CYP15G0201DXB clock multiplier (controlled by TXRATE) and by the level on the SPDSEL input.

SPDSEL is a 3-level select^[10] (ternary) input that selects one of three operating ranges for the serial data outputs and inputs. The operating serial signaling-rate and allowable range of REFCLK frequencies are listed in Table 10.

Table 10. Operating Speed Settings

| SPDSEL | TXRATE | REFCLK Frequency (MHz) | Signaling Rate (MBd) |
|------------|--------|------------------------|----------------------|
| LOW | 1 | Reserved | 195–400 |
| | 0 | 19.5–40 | |
| MID (Open) | 1 | 20–40 | 400–800 |
| | 0 | 40–80 | |
| HIGH | 1 | 40–75 | 800–1500 |
| | 0 | 80–150 | |

When TXRATE = HIGH (Half-rate REFCLK), TXCKSEL = HIGH or MID (TXCLKx or TXCLKA selected to clock input register) is an invalid mode of operation.

The REFCLK± input is a differential input with each input internally biased to 1.4 V. If the REFCLK+ input is connected to a TTL, LVTTTL, or LVCMOS clock source, the input signal is recognized when it passes through the internally biased reference point.

When both the REFCLK+ and REFCLK– inputs are connected, the clock source must be a differential clock. This can be either a differential LVPECL clock that is DC-or AC-coupled, or a differential LVTTTL or LVCMOS clock.

By connecting the REFCLK– input to an external voltage source or resistive voltage divider, it is possible to adjust the reference point of the REFCLK+ input for alternate logic levels. When doing so it is necessary to ensure that the 0 V differential crossing point remains within the parametric range supported by the input.

CYP15G0201DXB Receive Data Path

Serial Line Receivers

Two differential line receivers, INx1± and INx2±, are available on each channel for accepting serial data streams. The active serial line receiver on a channel is selected using the associated INSELx input. The serial line receiver inputs are differential, and can accommodate wire interconnect and filtering losses or transmission line attenuation greater than 16 dB. For normal operation, these inputs should receive a signal of at least $V_{I_DIFF} \geq 100$ mV, or 200 mV peak-to-peak differential. Each Line Receiver can be DC- or AC-coupled to +3.3 V powered fiber-optic interface modules (any ECL/PECL logic family, not limited to 100 K PECL) or AC-coupled to +5 V powered optical modules. The common-mode tolerance of these line receivers accommodates a wide range of signal termination voltages. Each receiver provides internal DC-restoration, to the center of the receiver's common mode range, for AC-coupled signals.

The local loopback input (LPEN) allows the serial transmit data outputs to be routed internally back to the clock and data recovery circuit associated with each channel. When configured for local loopback, all transmit serial driver outputs are forced to output a differential logic-1. This prevents local diagnostic patterns from being broadcast to attached remote receivers.

Note

10. 3-Level select inputs are used for static configuration. They are ternary (not binary) inputs that make use of non-standard logic levels of LOW, MID, and HIGH. The LOW level is usually implemented by direct connection to V_{SS} (ground). The HIGH level is usually implemented by direct connection to V_{CC} (power). When not connected or allowed to float, a 3-level select input self-biases to the MID level.

Signal Detect/Link Fault

Each selected line receiver (that is, that routed to the clock and data recovery PLL) is simultaneously monitored for

- Analog amplitude above limit specified by SDASEL
- Transition density greater than specified limit
- Range controller reports the received data stream within normal frequency range (± 1500 ppm)^[11]
- Receive channel enabled

All of these conditions must be valid for the signal detect block to indicate a valid signal is present. This status is presented on the link fault indicator (LFIx) output associated with each receive channel, which changes synchronous to the selected receive interface clock.

Table 11. Analog Amplitude Detect Valid Signal Levels^[12]

| SDASEL | Typical signal with peak amplitudes above |
|------------|---|
| LOW | 140 mV p-p differential |
| MID (Open) | 280 mV p-p differential |
| HIGH | 420 mV p-p differential |

Analog Amplitude

While the majority of these signal monitors are based on fixed constants, the analog amplitude level detection is adjustable to allow operation with highly attenuated signals, or in high-noise environments. This adjustment is made through the SDASEL signal, a 3-level select^[13] input, which sets the trip point for the detection of a valid signal at one of three levels, as listed in Table 11. This control input effects the analog monitors for all receive channels.

The analog signal detect monitors are active for the line receiver, selected by the associated INSELx input. When configured for local loopback (LPEN = HIGH), no line receivers are selected, and the LFIx output for each channel reports only the receive VCO frequency out-of-range and transition density status of the associated transmit signal. When local loopback is active, the analog signal detect monitors are disabled.

Transition Density

The transition detection logic checks for the absence of any transitions spanning greater than six transmission characters (60 bits). If no transitions are present in the data received on a channel (within the referenced period), the transition detection logic for that channel asserts LFIx. The LFIx output remains asserted until at least one transition is detected in each of three adjacent received characters.

Range Controls

Notes

11. REFCLK has no phase or frequency relationship with the recovered clock(s) and only acts as a centering reference to reduce clock synchronization time. REFCLK must be within ± 1500 ppm ($\pm 0.15\%$) of the remote transmitter's PLL reference (REFCLK) frequency. Although transmitting to a HOTLink II receiver necessitates the frequency difference between the transmitter and receiver reference clocks to be within ± 1500 ppm, the stability of the crystal needs to be within the limits specified by the appropriate standard when transmitting to a remote receiver that is compliant to that standard. For example, to be IEEE 802.3z Gigabit Ethernet compliant, the frequency stability of the crystal needs to be within ± 100 PPM.
12. The peak amplitudes listed in this table are for typical waveforms that have generally 3–4 transitions for every ten bits. In a worse case environment the signals may have a sign-wave appearance (highest transition density with repeating 0101...). Signal peak amplitudes levels within this environment type could increase the values in the table by approximately 100 mV.
13. 3-Level select inputs are used for static configuration. They are ternary (not binary) inputs that make use of non-standard logic levels of LOW, MID, and HIGH. The LOW level is usually implemented by direct connection to V_{SS} (ground). The HIGH level is usually implemented by direct connection to V_{CC} (power). When not connected or allowed to float, a 3-Level select input self-biases to the MID level.
14. When a disabled receive channel is re-enabled, the status of the associated LFIx output and data on the parallel outputs for the associated channel may be indeterminate for up to 10 ms.

The clock/data recovery (CDR) circuit includes logic to monitor the frequency of the phase-locked loop (PLL) voltage controlled oscillator (VCO) used to sample the incoming data stream. This logic ensures that the VCO operates at, or near the rate of the incoming data stream for two primary cases:

- when the incoming data stream resumes after a time in which it has been “missing”
- when the incoming data stream is outside the acceptable frequency range

To perform this function, the frequency of the VCO is periodically sampled and compared to the frequency of the REFCLK input. If the VCO is running at a frequency beyond ± 1500 ppm^[11] as defined by the reference clock frequency, it is periodically forced to the correct frequency (as defined by REFCLK, SPDSEL, and TXRATE) and then released in an attempt to lock to the input data stream. The sampling and relock period of the Range Control is calculated as follows: RANGE CONTROL SAMPLING PERIOD = (REFCLKPERIOD) × (16000).

During the time that the range control forces the PLL VCO to run at REFCLK×10 (or REFCLK×20 when TXRATE = HIGH) rate, the LFIx output is asserted LOW. While the PLL is attempting to re-lock to the incoming data stream, LFIx may be either HIGH or LOW (depending on other factors such as transition density and amplitude detection) and the recovered byte clock (RXCLKx) may run at an incorrect rate (depending on the quality or existence of the input serial data stream). After a valid serial data stream is applied, it may take up to one RANGE CONTROL SAMPLING PERIOD before the PLL locks to the input data stream, after which LFIx should be HIGH.

Receive Channel Enabled

The CYP15G0201DXB contains two receive channels that can be independently enabled and disabled. Each channel can be enabled or disabled separately through the BOE[3:0] inputs, as controlled by the RXLE latch-enable signal. When RXLE is HIGH, the signals present on the BOE[3:0] inputs are passed through the receive channel enable latch to control the PLLs and logic of the associated receive channel. The BOE[3:0] input associated with a specific receive channel is listed in Table 9.

When RXLE = HIGH and BOE[x] = HIGH, the associated receive channel is enabled to receive and decode a serial stream. When RXLE = HIGH and BOE[x] = LOW, the associated receive channel is disabled and internally configured for minimum power dissipation. If a single channel of a bonded-pair is disabled, the other receive channels may not bind correctly. If the disabled channel is selected as the master channel for insert/delete functions, or recovered clock select, these functions do not work correctly. Any disabled channel indicates an asserted LFIx output. When RXLE returns LOW, the values present on the BOE[3:0] inputs are latched in the receive channel enable latch, and remain there until RXLE returns HIGH to opened the latch again.^[14]

Clock/Data Recovery

The extraction of a bit-rate clock and recovery of bits from each received serial stream is performed by a separate CDR block within each receive channel. The clock extraction function is performed by high-performance embedded PLLs that track the frequency of the transitions in the incoming bit streams and align the phase of their internal bit-rate clocks to the transitions in the selected serial data streams.

Each CDR accepts a character-rate (bit-rate ÷ 10) or half-character-rate (bit rate ÷ 20) reference clock from the REFCLK input. This REFCLK input is used to

- Ensure that the VCO (within each CDR) is operating at the correct frequency (rather than some harmonic of the bit rate)
- Improve PLL acquisition time
- And to limit unlocked frequency excursions of the CDR VCO when no data is present at the selected Serial Line Receiver. Regardless of the type of signal present, the CDR attempts to recover a data stream from it. If the frequency of the recovered data stream is outside the limits set by the range control monitors, the CDR switches to track REFCLK instead of the data stream. After the CDR output (RXCLKx) frequency returns back close to REFCLK frequency, the CDR input is switched back to the input data stream to check its frequency. In case no data is present at the input this switching behavior may result in brief RXCLKx frequency excursions from REFCLK. However, the validity of the input data stream is indicated by the LFIx output. The frequency of REFCLK is required to be within ±1500 ppm^[11] of the frequency of the clock that drives the REFCLK input of the remote transmitter to ensure a lock to the incoming data stream.

For systems using multiple or redundant connections, the LFIx output can be used to select an alternate data stream. When an LFIx indication is detected, external logic can toggle selection of the associated INx1± and INx2± inputs through the associated INSELx input. When a port switch takes place, it is necessary for the receive PLL for that channel to reacquire the new serial stream and frame to the incoming character boundaries. If channel bonding is also enabled, a channel alignment event is also required before the output data may be considered usable.

Deserializer/Framer

Each CDR circuit extracts bits from the associated serial data stream and clocks these bits into the Shifter/Framer at the bit-clock rate. When enabled, the Framer examines the data stream looking for one or more Comma or K28.5 characters at all possible bit positions. The location of this character in the data stream is used to determine the character boundaries of all following characters.

Framing Character

The CYP15G0201DXB allows selection of two combinations of framing characters to support requirements of different interfaces. The selection of the framing character is made through the FRAMCHAR input.

The specific bit combinations of these framing characters are listed in Table 12. When the specific bit combination of the selected framing character is detected by the framer, the boundaries of the characters present in the received data stream are known.

Table 12. Framing Character Selector

| FRAMCHAR | Bits Detected in Framer | |
|------------|-------------------------|---|
| | Character Name | Bits Detected |
| LOW | Reserved for test | |
| MID (Open) | Comma+
Comma- | 00111110XX ^[15]
or 11000001XX |
| HIGH | -K28.5
+K28.5 | 0011111010 or
1100000101 |

Framer

The framer on each channel operates in one of three different modes, as selected by the RFMODE input. In addition, the framer itself may be enabled or disabled through the RFEN input. When RFEN = LOW, the framers in both receive paths are disabled, and no combination of bits in a received data stream alters the character boundaries. When RFEN = HIGH, the framer selected by RFMODE is enabled on both channels.

When RFMODE = LOW, the low-latency framer is selected. This framer operates by stretching the recovered character clock until it aligns with the received character boundaries. In this mode the framer starts its alignment process on the first detection of the selected framing character. To reduce the impact on external circuits that make use of a recovered clock, the clock period is not stretched by more than two bit-periods in any one clock cycle. When operated in with a character-rate output clock (RXRATE = LOW), the output of properly framed characters may be delayed by up to nine character-clock cycles from the detection of the selected framing character. When operated with a half-character-rate output clock (RXRATE = HIGH), the output of properly framed characters may be delayed by up to 14 character-clock cycles from the detection of the selected framing character.^[16]

When RFMODE is MID (open) the Cypress-mode multi-byte framer is selected. The required detection of multiple framing characters makes the associated link much more robust to incorrect framing due to aliased SYNC characters in the data stream. In this mode, the framer does not adjust the character clock boundary, but instead aligns the character to the already recovered character clock. This ensures that the recovered clock does not contain any significant phase changes or hops during normal operation or framing, and allows the recovered clock to be replicated and distributed to other external circuits or components using PLL-based clock distribution elements. In this framing mode the character boundaries are only adjusted if the selected framing character is detected at least twice within a span of 50 bits, with both instances on identical 10-bit character boundaries.

Notes

15. The standard definition of a Comma contains only seven bits. However, since all valid Comma characters within the 8B/10B character set also have the 8th bit as an inversion of the 7th bit, the compare pattern is extended to a full eight bits to reduce the possibility of a framing error.
16. When Receive BIST is enabled on a channel, the Low-latency Framer must not be enabled. The BIST sequence contains an aliased K28.5 framing character, which causes the Receiver to update its character boundaries incorrectly.

When RFMODE = HIGH, the alternate-mode multi-byte framer is enabled. Like the Cypress-mode multi-byte framer, multiple framing characters must be detected before the character boundary is adjusted. In this mode, the data stream must contain a minimum of four of the selected framing characters, received as consecutive characters, on identical 10-bit boundaries, before character framing is adjusted. In this mode, the Framer does not adjust the character clock boundary, but instead aligns the character to the already recovered character clock.

Framing for all channels is enabled when RFEN = HIGH. If RFEN = LOW, the framer for each channel is disabled. When the framers are disabled, no changes are made to the recovered character boundaries on any channel, regardless of the presence of framing characters in the data stream.

8B/10B Decoder Block

The decoder logic block performs three primary functions:

- Decoding the received transmission characters back into data and special character codes,
- Comparing generated BIST patterns with received characters to permit at-speed link and device testing,
- Generation of ODD parity on the decoded characters.

8B/10B Decoder

The framed parallel output of each deserializer shifter is passed to the 8B/10B decoder where, if the decoder is enabled (DECMODE \neq LOW), it is transformed from a 10-bit transmission character back to the original data and special character codes. This block uses the 8B/10B Decoder patterns in [Table 24 on page 43](#) and [Table 25 on page 47](#) of this datasheet. Valid data characters are indicated by a 000b bit-combination on the associated RXSTx[2:0] status bits, and special character codes are indicated by a 001b bit-combination on these same status outputs. Framing characters, invalid patterns, disparity errors, and synchronization status are presented as alternate combinations of these status bits.

The 8B/10B decoder operates in two normal modes, and can also be bypassed. The operating mode for the Decoder is controlled by the DECMODE input.

When DECMODE = LOW, the decoder is bypassed and raw 10-bit characters are passed to the output register. In this mode, channel bonding is not possible, the receive Elasticity Buffers are bypassed, and RXCKSEL must be MID. This clock mode generates separate RXCLKx± outputs for each receive channel.

When DECMODE = MID (or open), the 10-bit transmission characters are decoded using [Table 24 on page 43](#) and [Table 25 on page 47](#). Received Special Code characters are decoded using the Cypress column of [Table 25 on page 47](#).

When DECMODE = HIGH, the 10-bit transmission characters are decoded using [Table 24 on page 43](#) and [Table 25 on page 47](#). received special code characters are decoded using the Alternate column of [Table 25 on page 47](#).

In all settings where the decoder is enabled, the receive paths may be operated as separate channels or bonded to form dual-channel buses.

Receive BIST Operation

The receiver interfaces contain internal pattern generators that can be used to validate both device and link operation. These generators are enabled by the associated BOE[x] signals listed in [Table 9 on page 18](#) (when the BISTLE latch enable input is HIGH). When enabled, a register in the associated receive channel becomes a signature pattern generator and checker by logically converting to a linear feedback shift register (LFSR). This LFSR generates a 511-character sequence that includes all data and special character codes, including the explicit violation symbols. This provides a predictable yet pseudo-random sequence that can be matched to an identical LFSR in the attached transmitter(s). If the receive channels are configured for common clock operation (RXCKSEL \neq MID) each pass is preceded by a 16-character word sync sequence. When synchronized with the received data stream, the associated Receiver checks each character in the decoder with each character generate by the LFSR and indicates compare errors and BIST status at the RXSTx[2:0] bits of the output register. Refer [Table 20 on page 30](#) for details.

When the BISTLE signal is HIGH, any BOE[x] input that is LOW enables the BIST generator/checker in the associated receive channel (or the BIST generator in the associated transmit channel). When BISTLE returns LOW, the values of all BOE[x] signals are captured in the BIST enable latch. These values remain in the BIST Enable Latch until BISTLE is returned HIGH. All captured signals in the BIST Enable Latch are set HIGH (that is, BIST is disabled) following a device reset (TRSTZ is sampled LOW).

When BIST is first recognized as being enabled in the Receiver, the LFSR is preset to the BIST-loop start-code of D0.0 This code D0.0 is sent only once per BIST loop. The status of the BIST progress and any character mismatches is presented on the RXSTx[2:0] status outputs.

Code rule violations or running disparity errors that occur as part of the BIST loop do not cause an error indication. RXSTx[2:0] indicates 010b or 100b for one character period per BIST loop to indicate loop completion. This status can be used to check test pattern progress. These same status values are presented when the decoder is bypassed and BIST is enabled on a receive channel.

The specific status reported by the BIST state machine are listed in [Table 18 on page 27](#). These same codes are reported on the receive status outputs regardless of the state of DECMODE.

The specific patterns checked by each receiver are described in detail in the Cypress application note entitled "HOTLink built-in self-test." The sequence compared by the CYP15G0201DXB when RXCKSEL = MID is identical to that in the CY7B933 and CY7C924DX, allowing interoperable systems to be built when used at compatible serial signaling rates.

If the number of invalid characters received ever exceeds the number of valid characters by 16, the receive BIST state machine aborts the compare operations and resets the LFSR to the D0.0 state to look for the start of the BIST sequence again.

When the receive paths are configured for common clock operation (RXCKSEL \neq MID) each pass must be preceded by a 16-character Word Sync Sequence to allow output buffer alignment and management of clock frequency variations.

This is automatically generated by the transmitter when its local RXCKSEL \neq MID and encoder is enabled.

The BIST state machine requires the characters to be correctly framed for it to detect the BIST sequence. If the Low Latency framer is enabled (RFMODE = LOW), the framer misaligns to an aliased SYNC character within the BIST sequence. If the alternate multi-byte framer is enabled (RFMODE = HIGH) and the Receiver outputs are clocked relative to a recovered clock, it is generally necessary to frame the receiver before BIST is enabled. If the receive outputs are clocked relative to REFCLK (RXCKSEL = LOW), the transmitter precedes every 511 character BIST sequence with a 16-character Word Sync Sequence.

Receive Elasticity Buffer

Each receive channel contains an elasticity buffer that is designed to support multiple clocking modes. These buffers allow data to be read using an elasticity buffer read-clock that is asynchronous in both frequency and phase from the elasticity buffer write clock, or to use a read clock that is frequency coherent but with uncontrolled phase relative to the elasticity buffer write clock.

Each elasticity buffer is a minimum of 10 characters deep, and supports a 12-bit-wide data path. It is capable of supporting a decoded character, three status bits, and a parity bit for each character present in the buffer. The write clock for these buffers is always the recovered clock for the associated read channel.

The read clock for the elasticity buffers may come from one of three selectable sources. It may be a,

- Character-rate REFCLK
- Recovered clock from the same receive channel
- Recovered clock from an alternate receive channel

These elasticity buffers are also used to align the output data streams when both channels are bonded together. More details on how the elasticity buffer is used for independent channel modes and channel bonded modes is discussed in the next section. The elasticity buffers are bypassed whenever the decoders are bypassed (DECMODE = LOW). When the decoders and elasticity buffers are bypassed, RXCKSELx must be set to MID.

Receive Modes

The operating mode of the receive path is set through the RXMODE[1:0] inputs. The 'Reserved for test' settings (RXMODE0=M) is not allowed, even if the receiver is not being used. A[1:0] settings are ignored as long as they are not test modes. It stops normal function of the device. When the decoder is disabled, the RX MODE. These modes determine the type (if any) of channel bonding and status reporting. The different receive modes are listed in Table 13. When RXMODE[1] = MID or RXMODE[0] = MID the resulting modes are reserved for test.

Table 13. Receive Operating Modes

| RX Mode | | Operating Mode | |
|-------------|--------------|-----------------|------------------------|
| Mode Number | RXMODE [1:0] | Channel Bonding | RXSTx Status Reporting |
| 0 | LL | Independent | Status A |
| 1 | LH | Independent | Status B |
| 2 | HL | Dual | Status A |
| 3 | HH | Dual | Status B |

Independent Channel Modes

In independent channel modes (RX Modes 0 and 1, where RXMODE[1] = LOW), both receive paths may be clocked in any clock mode selected by RXCKSEL.

When RXCKSEL = LOW, both channels are clocked by REFCLK. RXCLKB± output is disabled (High-Z), and the RXCLKA± and RXCLKC+ outputs presents buffered and delayed forms of REFCLK. In this mode, the receive elasticity buffers are enabled. For REFCLK clocking, the elasticity buffers must be able to insert K28.5 characters and delete framing characters as appropriate.

The insertion of a K28.5 or deletion of a framing character can occur at any time on any channel, however, the actual timing on these insertions and deletions is controlled in part by the how the transmitter sends its data. Insertion of a K28.5 character can only occur when the receiver has a framing character in the elasticity buffer. Likewise, to delete a framing character, one must also be in the elasticity buffer. To prevent a receive buffer overflow or underflow on a receive channel, a minimum density of framing characters must be present in the received data streams.

When RXCKSEL = MID (or open), each received channel output register is clocked by the recovered clock for that channel. Since no characters may be added or deleted, the receiver elasticity buffer is bypassed.

When RXCKSEL = HIGH, all channels are clocked by the selected recovered clock. This selected clock is always output on RXCLKA±. In this mode the receive elasticity buffers are enabled. When data is output using a recovered clock (RXCKSEL = HIGH), receive channels are not allowed to insert and delete characters, except as necessary for elasticity buffer alignment.

When the elasticity buffer is used, prior to delivery of valid data, a word sync sequence (or at least four framing characters) must be received to center the elasticity buffers. The elasticity buffer may also be centered by a device reset operation initiated through the TRSTZ input, however, following such an event the CYP15G0201DXB normally requires a framing event before it correctly decodes the characters. When RXCKSEL = HIGH,

since the Elasticity buffer is not allowed to insert or delete framing characters, the transmit clocks on all received channels must all be from a common source.

Dual-channel Bonded Modes

In dual-channel bonded modes (RX Modes 2 and 3, where RXMODE[1] = HIGH), the associated receive channel pair Output Registers must be clocked by a common clock. This mode does not operate when RXCKSEL = MID.

Proper operation in this mode requires that the associated transmit data streams are clocked from a common reference with no long-term character slippage between the bonded channels. In dual-channel mode this means that channels A and B must be clocked from a common reference.

Prior to the reception of valid data, a word sync sequence (or that portion of one necessary to align the receive buffers) must be received on the bonded channels (within the allowable inter-channel skew window) to allow the receive elasticity buffers to be centered. While normal characters may be output prior to this alignment event, they are not necessarily aligned within the same word boundaries as when they were transmitted.

When RXCKSEL = LOW, both receive channels are clocked by REFCLK. RXCLKB± outputs are disabled (High-Z), and the RXCLKA± and RXCLKC+ outputs present buffered and delayed forms of REFCLK. In this mode, the receive Elasticity Buffers are enabled. For REFCLK clocking, the elasticity buffers must be able to insert K28.5 characters and delete framing characters as appropriate. While these insertions and deletions can take place at any time, they must occur at the same time on both channels that are bonded together. This is necessary to keep the data in the bonded channel-pair properly aligned. This insert and delete process is controlled by the master channel selected by the RXCLKB+ input as listed in Table 14.

When RXCKSEL = HIGH, the A and B channels are clocked by the selected recovered clock, as shown in Table 14. The output clock for the channel A/B bonded-pair is output continuously on RXCLKA±. The clock source for this output is selected from the recovered clock for channel A or channel B using the RXCLKB+ input.

Table 14. Dual-Channel Bonded Recovered Clock Select and Master Channel Select

| RXCLKB+ | Clock Source |
|---------|--------------|
| | RXCLKA± |
| 0 | RXCLKA |
| 1 | RXCLKB |

When data is output using a recovered clock (RXCKSEL = HIGH), receive channels are not allowed to insert and delete characters, except as necessary for elasticity buffer alignment.

Power Control

The CYP15G0201DXB supports user control of the powered-up or down state of each transmit and receive channel. The receive channels are controlled by the RXLE signal and values present on the BOE [3:0] bus. The transmit channels are controlled by the OELE signal and the values present on the BOE[3:0] bus. Powering down unused channels saves power and reduces system heat generation. Controlling system power dissipation improves the system performance.

Receive Channels

When RXLE = HIGH, the signals on the BOE[3:0] inputs directly control the power enables for the receive PLLs and analog circuits. When a BOE[3:0] input is HIGH, the associated receive channel [A and B] PLL and analog logic are active. When a BOE[3:0] input is LOW, the associated receive channel [A and B] PLL and analog logic are powered down. When RXLE returns LOW, the last values present on the BOE[3:0] inputs are captured. The specific BOE[3:0] input signal associated with a receive channel is listed in Table 9 on page 18.

Any disabled receive channel indicates a constant LFix output.

When a disable receive channel is re-enabled, the status of the associated LFix output and data on the parallel outputs for the associated channel may be indeterminate for up to 10 ms.

Transmit Channels

When OELE is HIGH, the signals on the BOE[3:0] inputs directly control the power enables for the serial drivers. When BOE[3:0] input is HIGH, the associated serial driver is enabled. When BOE[3:0] input is LOW, the associated Serial Driver is disabled and powered down. If both serial drivers of a channel are disabled, the internal logic for that channel is powered down. When OELE returns LOW, the value present on the BOE[3:0] inputs are latched in the output enable latch.

Device Reset State

When the CYP15G0201DXB is reset by the assertion of TRSTZ, the transmit enable and receive enable latches are both cleared, and the BIST enable latch is preset. In this state, all transmit and receive channels are disabled, and BIST is disabled on all channels.

Following a device reset, it is necessary to enable the transmit and receive channels used for normal operation. This can be done by sequencing the appropriate values on the BOE[3:0] inputs while the OELE and RXLE signals are raised and lowered. For systems that do not require dynamic control of power, or want the device to power-up in a fixed configuration, it is also possible to strap the RXLE and OELE control signals HIGH to permanently enable their associated latches. Connection of the associated BOE[3:0] signals HIGH, enables the respective transmit and receive channels as soon as the TRSTZ signal is deasserted.

Output Bus

Each receive channel presents a 12-signal output bus consisting of,

- an 8-bit data bus
- a 3-bit status bus
- a parity bit.

The signals present on this output bus are modified by the present operating mode of the CYP15G0201DXB as selected by DECMODE. The bits are assigned per Table 15.

Table 15. Output Register Bit Assignments^[17]

| Signal Name | DECMODE = LOW | DECMODE = MID or HIGH |
|----------------|---------------|-----------------------|
| RXSTx[2] (LSb) | COMDETx | RXSTx[2] |
| RXSTx[1] | DOUTx[0] | RXSTx[1] |
| RXSTx[0] | DOUTx[1] | RXSTx[0] |
| RxDx[0] | DOUTx[2] | RxDx[0] |
| RxDx[1] | DOUTx[3] | RxDx[1] |
| RxDx[2] | DOUTx[4] | RxDx[2] |
| RxDx[3] | DOUTx[5] | RxDx[3] |
| RxDx[4] | DOUTx[6] | RxDx[4] |
| RxDx[5] | DOUTx[7] | RxDx[5] |
| RxDx[6] | DOUTx[8] | RxDx[6] |
| RxDx[7] (MSb) | DOUTx[9] | RxDx[7] |

When the 8B/10B decoder is bypassed (DECMODE = LOW), the framed 10-bit and a single status bit are presented at the receiver output register. The status output indicates if the character in the output register is one of the selected framing characters. The bit usage and mapping of the external signals to the raw 10B transmission character is shown in Table 16.

Table 16. Decoder Bypass Mode (DECMODE = LOW)

| Signal Name | Bus Weight | 10B Name |
|----------------|----------------|----------|
| RXSTx[2] (LSb) | COMDETx | |
| RXSTx[1] | 2 ⁰ | a |
| RXSTx[0] | 2 ¹ | b |
| RxDx[0] | 2 ² | c |
| RxDx[1] | 2 ³ | d |
| RxDx[2] | 2 ⁴ | e |
| RxDx[3] | 2 ⁵ | i |
| RxDx[4] | 2 ⁶ | f |
| RxDx[5] | 2 ⁷ | g |
| RxDx[6] | 2 ⁸ | h |
| RxDx[7] (MSb) | 2 ⁹ | j |

The COMDETx status outputs operate the same regardless of the bit combination selected for character framing by the FRAMCHAR input. They are HIGH when the character in the Output Register contains the selected framing character at the

Note

17. The RXOPx outputs are also driven from the associated Output Register, but their interpretation is under the separate control of PARCTL.

proper character boundary, and LOW for all other bit combinations.

When the low-latency framer and half-rate receive port clocking are also enabled (RFMODE = LOW, RXRATE = HIGH, and RXCKSEL ≠ LOW), the framer stretches the recovered clock to the nearest 20-bit boundary such that the rising edge of RXCLKx+ occurs when COMDETx is present on the associated output bus.

When the Cypress or Alternate Mode Framer is enabled and half-rate receive port clocking is also enabled (RFMODE ≠ LOW and RXRATE = HIGH), the output clock is not modified when framing is detected, but a single pipeline stage may be added or subtracted from the data stream by the framer logic such that the rising edge of RXCLKx+ occurs when COMDETx is present on the associated output bus.

This adjustment only occurs when the framer is enabled (RFEN = HIGH). When the framer is disabled, the clock boundaries are not adjusted, and COMDETx may be asserted during the rising edge of RXCLKx– (if an odd number of characters were received following the initial framing).

Parity Generation

In addition to the eleven data and status bits that are presented by each channel, an RXOPx parity output is also available on each channel. This allows the CYP15G0201DXB to support ODD parity generation for each channel. To handle a wide range of system environments, the CYP15G0201DXB supports multiple different forms of parity generation including no parity. When the decoders are enabled (DECMODE ≠ LOW), parity can be generated on

- the RxDx[7:0] character
 - the RxDx[7:0] character and RXSTx[2:0] status.
- When the decoders are bypassed (DECMODE = LOW), parity can be generated on
- the RxDx[7:0] and RXSTx[1:0] bits
 - the RxDx[7:0] and RXSTx[2:0] bits.

These modes differ in the number bits which are included in the parity calculation. For all cases, only ODD parity is provided which ensures that at least one bit of the data bus is always a logic-1. Those bits covered by parity generation are listed in Table 17 on page 26.

Parity generation is enabled through the 3-level select PARCTL input. When PARCTL = LOW, parity checking is disabled, and the RXOPx outputs are all disabled (High-Z).

When PARCTL = MID (open) and the decoders are enabled (DECMODE ≠ LOW), ODD parity is generated for the received and decoded character in the RxDx[7:0] signals and is presented on the associated RXOPx output.

When PARCTL = MID (open) and the decoders are bypassed (DECMODE = LOW), ODD parity is generated for the received and decoded character in the RxDx[7:0] and RXSTx[1:0] bit positions.

When PARCTL = HIGH, ODD parity is generated for the RxDx[7:0] and the associated RXSTx[2:0] status bits.

Receive Status Bits

When the 8B/10B decoder is enabled (DECMODE \neq LOW), each character presented at the output register includes three associated status bits. These bits are used to identify

- if The contents of the data bus are valid
- The type of character present
- The state of receive BIST operations (regardless of the state of DECMODE)
- Character violations
- And channel bonding status

These conditions normally overlap; that is, a valid data character received with incorrect running disparity is not reported as a valid data character. It is instead reported as a decoder violation of some specific type. This implies a hierarchy or priority level to the various status bit combinations. The hierarchy and value of each status is listed in [Table 18 on page 27](#) when channel bonding enabled and in [Table 19 on page 30](#) when channel bonding is disabled.

Table 17. Output Register Parity Generation

| Signal Name | Receive Parity Generate Mode (PARCTL) | | | |
|-------------|---------------------------------------|---------------|--------------------|-------------------|
| | LOW ^[18] | MID | | HIGH |
| | | DECMODE = LOW | DECMODE \neq LOW | |
| RXSTx[2] | | | | X ^[19] |
| RXSTx[1] | | X | | X |
| RXSTx[0] | | X | | X |
| RXDx[0] | | X | X | X |
| RXDx[1] | | X | X | X |
| RXDx[2] | | X | X | X |
| RXDx[3] | | X | X | X |
| RXDx[4] | | X | X | X |
| RXDx[5] | | X | X | X |
| RXDx[6] | | X | X | X |
| RXDx[7] | | X | X | X |

Receive Synchronization State Machine When Channel Bonding is Enabled

Each receive channel contains a Receive Synchronization State Machine. This machine handles loss and recovery of bit, channel, and word framing, and part of the control for channel bonding. This state machine is enabled whenever the receive channels are configured for channel bonding (RXMODE[1] \neq LOW). Separate forms of the state machine exist for the two

different types of status reporting. When operated without channel bonding (RXMODE[1] = LOW, RX Modes 0 and 1), these state machines are disabled and characters are decoded directly. In RX Mode 0 the RESYNC (111b) status is never reported. In RX Mode 1, neither the RESYNC (111b) or Channel Lock Detected (010b) status are reported.

Status Type-A Receive State Machine

This machine has four primary states: NO_SYNC, RESYNC, COULD_NOT_BOND, and IN_SYNC, as shown in [Figure 2 on page 28](#). The IN_SYNC state can respond with multiple status types, while others can respond with only one type.

Status Type-B Receive State Machine

This machine has four primary states: NO_SYNC, RESYNC, IN_SYNC, and RESYNC_IN_SYNC, as shown in [Figure 3 on page 29](#). Some of these state can respond with only one status value, while others can respond with multiple status types.

BIST Status State Machine

When a receive path is enabled to look for and compare the received data stream with the BIST pattern, the RXSTx[2:0] bits identify the present state of the BIST compare operation.

Within these status decodes, there are three modes of status reporting. The two normal or data status reporting modes (Type A and Type B) are selectable through the RXMODE[0] input. These status types allow compability with legacy systems, while allowing full reporting in new systems. The third status mode is used for reporting receive BIST status and progress. These status values are generated in part by the Receive Synchronization State Machine, and are listed in [Table 18 on page 27](#). The receive status when the channels are operated independently with channel bonding disabled is shown in [Table 19 on page 30](#). The receive status when Receive BIST is enabled is shown in [Table 20 on page 30](#).

The BIST state machine has multiple states, as shown in [Figure 4 on page 31](#) and [Table 18 on page 27](#). When the receive PLL detects an out-of-lock condition, the BIST state is forced to the Start-of-BIST state, regardless of the present state of the BIST state machine. If the number of detected errors ever exceeds the number of valid matches by greater than 16, the state machine is forced to the WAIT_FOR_BIST state where it monitors the interface for the first character of the next BIST sequence (D0.0). Also, if the Elasticity Buffer ever hits and overflow/underflow condition, the status is forced to the BIST_START until the buffer is re centered (approximately nine character periods).

To ensure compatibility between the source and destination BIST operating modes, the sending and receiving ends of the link must use the same receive clock setup (RXCKSEL = MID or RXCKSEL \neq MID).

Notes

18. Receive path parity output drivers (RXOPx) are disabled (High-Z) when PARCTL = LOW.

19. When the Decoder is bypassed (DECMODE = LOW) and BIST is not enabled (Receive BIST Latch output is HIGH), RXSTx[2] is driven to a logic-0, except when the character in the output buffer is a framing character.

Table 18. Receive Character Status Bits when Channel Bonding is Enabled

| RXSTx[2:0] | Priority | Description | |
|------------|----------|---|---|
| | | Type-A Status | Type-B Status |
| 000 | 7 | Normal Character Received. The valid data character on the output bus meets all the formatting requirements of data characters listed in Table 24 on page 43 . | |
| 001 | 7 | Special Code Detected. The valid special character on the output bus meets all the formatting requirements of special code characters listed in Table 25 on page 47 , but is not the presently selected framing character or a Decoder violation indication. | |
| 010 | 2 | Receive Elasticity Buffer Underrun/Overrun Error. The receive buffer was not able to add/drop a K28.5 or framing character. | Channel Lock Detected. Asserts when the bonded channels have detected RESYNC within the allotted window. Presented only on the last cycle before aligned data is presented. |
| 011 | 5 | Framing Character Detected. This indicates that a character matching the patterns identified as a framing character (as selected by FRAMCHAR) was detected. The decoded value of this character is present in the associated output bus. | |
| 100 | 4 | Codeword Violation. The character on the output bus is a C0.7. This indicates that the received character cannot be decoded into any valid character. | |
| 101 | 1 | Loss of Sync. The character on the bus is invalid, due to an event that has caused the receive channels to lose synchronization. When channel bonding is enabled, this indicates that one or more channels have either lost bit synchronization (loss of character framing), or that the bonded channels are no longer in proper character alignment. When the channels are operated independently (with the Decoder enabled), this indicates a PLL Out of Lock condition. | Loss of Sync. The character on the bus is invalid, due to an event that has caused the receive channels to lose synchronization. When channel bonding is enabled, this indicates that one or more channels have either lost bit synchronization (loss of character framing), or that the bonded channels are no longer in proper character alignment. When the channels are operated independently (with the Decoder enabled), this indicates a PLL Out of lock condition. Also used to indicate receive Elasticity buffer underflow/ overflow errors. |
| 110 | 6 | Running Disparity Error. The character on the output bus is a C4.7, C1.7, or C2.7. | |
| 111 | 3 | Resync. The receiver state machine is in the Resynchronization state. In this state the data on the output bus reflects the presently decoded FRAMCHAR. | |

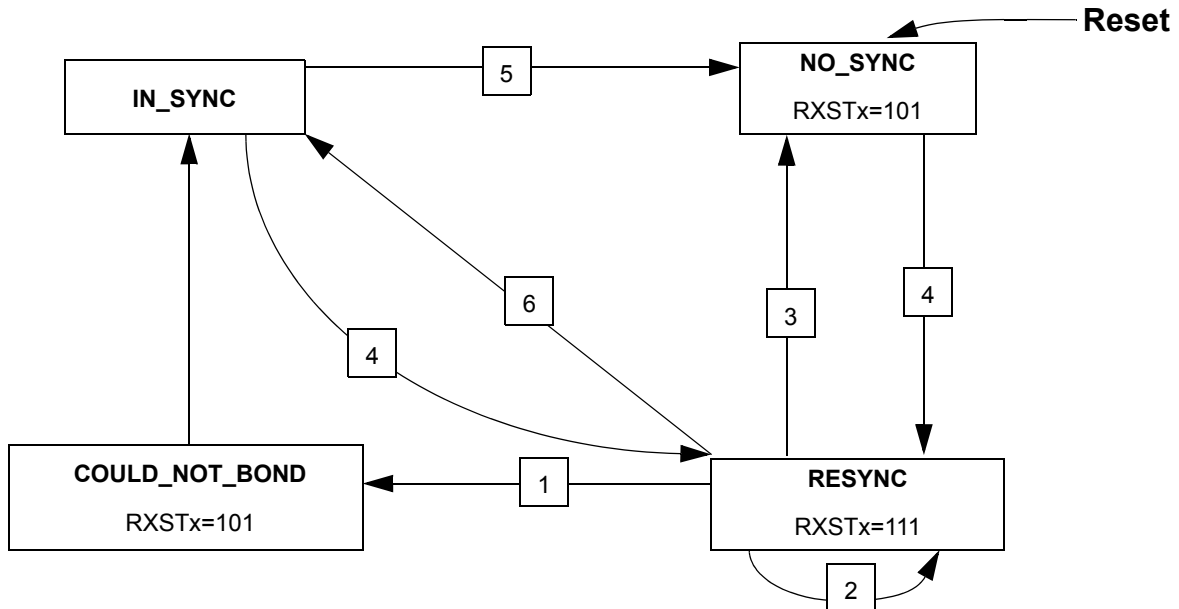
Figure 2. Status Type-A Receive State Machine

| # | State Transition Conditions |
|---|--|
| 1 | Deskew window expired |
| 2 | FRAMCHAR detected |
| 3 | (Elasticity buffer under/overrun) OR (RX PLL Loss of Lock) OR (Any Decoder Error) |
| 4 | Four consecutive FRAMCHAR detected |
| 5 | (Elasticity buffer under/overrun) OR (RX PLL Loss of lock) OR (four consecutive decoder errors) OR (invalid minus valid = 4) |
| 6 | Valid character other than a FRAMCHAR |

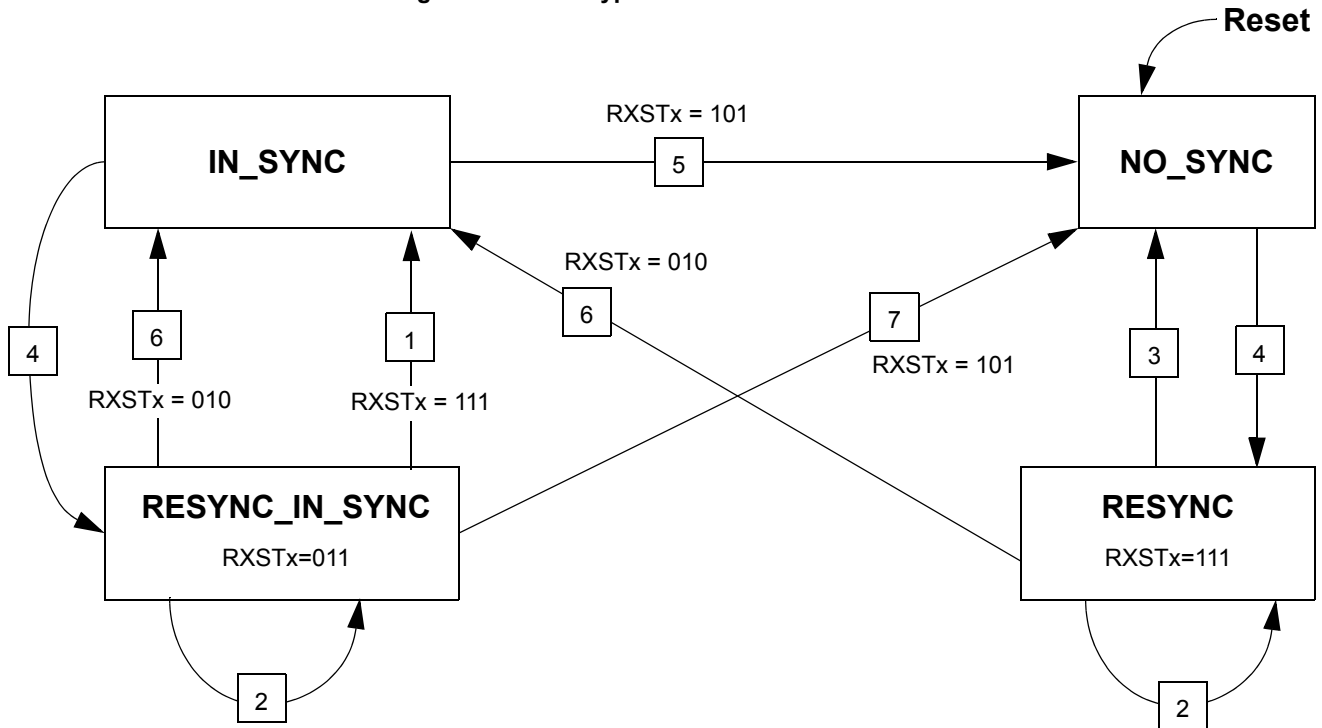
Figure 3. Status Type-B Receive State Machine

| # | Conditions |
|---|---|
| 1 | (Channels did not bond) AND (deskew window expired) OR (decoder error) |
| 2 | FRAMCHAR Detected |
| 3 | (elasticity buffer under/overflow) OR (RX PLL loss of lock) OR (any decoder error) OR ((channels did not bond) and (deskew window expired)) |
| 4 | Four consecutive FRAMCHAR detected |
| 5 | (Elasticity buffer under/overflow) OR (RX PLL loss of lock) OR (four consecutive decoder errors) OR (invalid minus valid = 4) |
| 6 | Last FRAMCHAR before a valid character AND bonded |
| 7 | (Elasticity buffer under/overflow) OR (RX PLL loss of lock) |

Table 19. Receive Character Status when Channels are Operated in Independent Mode (RXMODE[1:0] = LL or H)

| RXSTx[2:0] | Priority | Type-A Status | Type-B Status |
|------------|----------|---|----------------|
| 000 | 7 | Normal Character Received. The valid data character with the correct running disparity received | |
| 001 | 7 | Special Code Detected. Special code other than the selected framing character or decoder violation received | |
| 010 | 2 | Receive Elasticity Buffer underrun/overflow error. The receive elasticity buffer was not able to add/drop a K28.5 or framing character. | INVALID |
| 011 | 5 | Framing Character Detected. This indicates that a character matching the patterns identified as a framing character was detected. The decoded value of this character is present on the associated output bus. | |
| 100 | 4 | Codeword Violation. The character on the output bus is a C0.7. This indicates that the received character cannot be decoded into any valid character. | |
| 101 | 1 | PLL Out Of Lock Indication | |
| 110 | 6 | Running Disparity Error. The character on the output bus is a C4.7, C1.7 or C2.7 | |
| 111 | 3 | INVALID | |

Table 20. Receive Character Status when Channels are Operated to Receive BIST Data

| RXSTx[2:0] | Priority | Receive BIST Status
(Receive BIST = Enabled) |
|------------|----------|--|
| 000 | 7 | BIST Data Compare. Character compared correctly |
| 001 | 7 | BIST Command Compare. Character compared correctly |
| 010 | 2 | BIST Last Good. Last Character of BIST sequence detected and valid. |
| 011 | 5 | RESERVED for TEST |
| 100 | 4 | BIST Last Bad. Last Character of BIST sequence detected invalid. |
| 101 | 1 | BIST Start. Receive BIST is enabled on this channel, but character compares have not yet commenced. This also indicates a PLL Out of Lock condition, and Elasticity Buffer overflow/underflow conditions. |
| 110 | 6 | BIST Error. While comparing characters, a mismatch was found in one or more of the decoded character bits. |
| 111 | 3 | BIST Wait. The receiver is comparing characters. but has not yet found the start of BIST character to enable the LFSR. |

JTAG Support

The CYP15G0201DXB contains a JTAG port to allow system level diagnosis of device interconnect. Of the available JTAG modes, only boundary scan is supported. This capability is present only on the LVTTTL inputs and outputs and the REFCLK± clock input. The high-speed serial inputs and outputs are not part of the JTAG test chain.

JTAG ID

The JTAG device ID for the CYP15G0201DXB is '1C80C069'x.

3-Level Select Inputs

Each 3-Level select input reports as two bits in the scan register. These bits report the LOW, MID, and HIGH state of the associated input as 00, 10, and 11, respectively.

Figure 4. Receive BIST State Machine

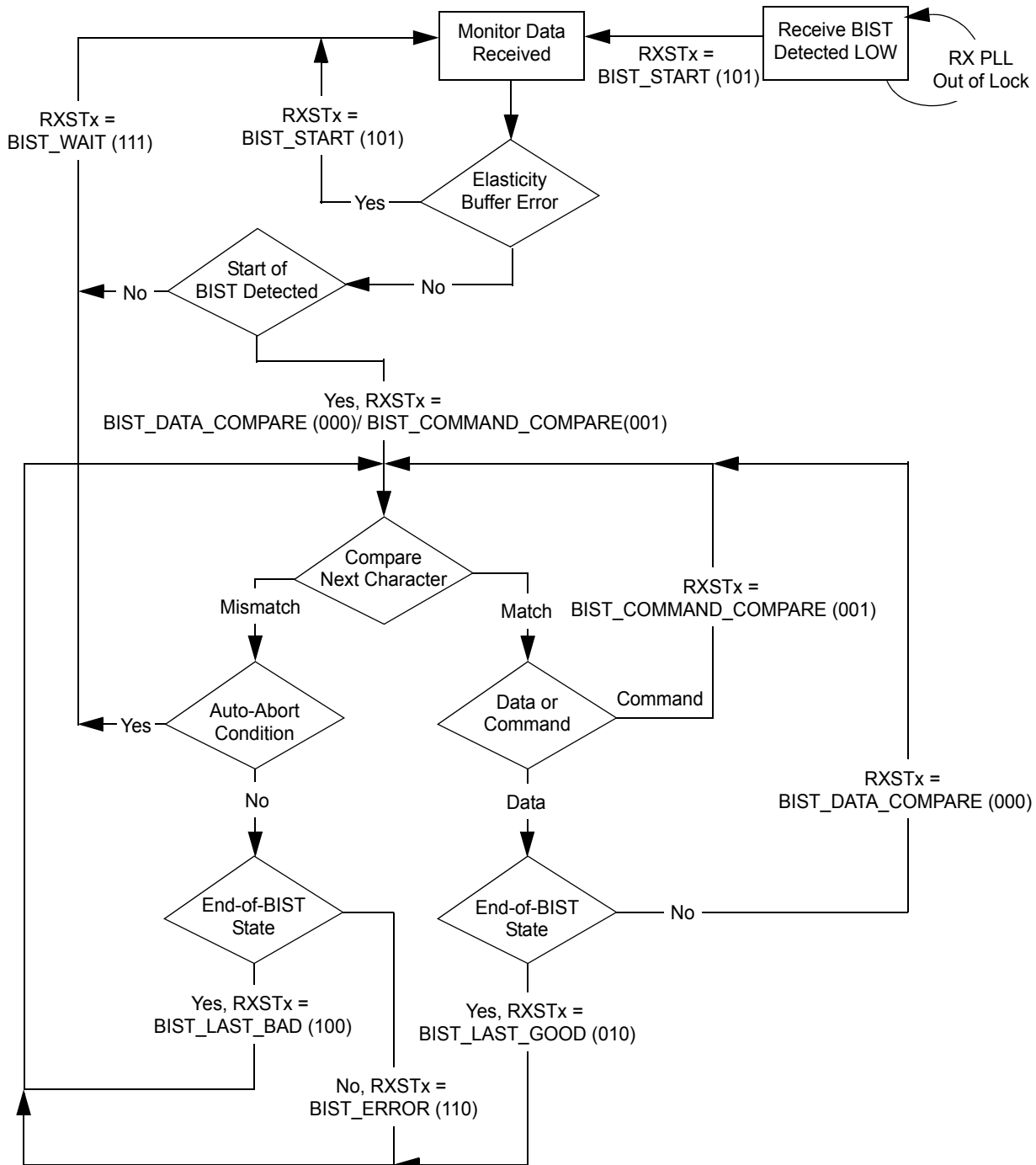

Maximum Ratings

Exceeding maximum ratings may shorten the useful life of the device. User guidelines are not tested.

| | |
|---|----------------------------|
| Storage temperature | -65 °C to +150 °C |
| Ambient temperature with Power applied | -55 °C to +125 °C |
| Supply voltage to ground potential | -0.5 V to +3.8 V |
| DC voltage applied to LVTTL outputs in High-Z state | -0.5 V to $V_{CC} + 0.5 V$ |
| Output current into LVTTL outputs (LOW) | 60 mA |
| DC input voltage | -0.5 V to $V_{CC} + 0.5 V$ |

| | |
|---|----------|
| Static discharge voltage (per MIL-STD-883, Method 3015) | > 2000 V |
| Latch-up current | > 200 mA |

Power-up requirements: The CYP15G0201DXB requires one power-supply. The voltage on any input or I/O pin cannot exceed the power pin during power-up.

Operating Range

| Range | Ambient Temp | V_{CC} |
|------------|------------------|------------------|
| Commercial | 0 °C to +70 °C | +3.3 V $\pm 5\%$ |
| Industrial | -40 °C to +85 °C | +3.3 V $\pm 5\%$ |

CYP15G0201DXB DC Electrical Characteristics

Over the Operating Range

| Parameter | Description | Test Conditions | Min | Max | Unit |
|--|--|---|----------------------|------------------------|---------------|
| LVTTL-compatible Outputs | | | | | |
| V_{OHT} | Output HIGH voltage | $I_{OH} = -4 \text{ mA}, V_{CC} = \text{Min}$ | 2.4 | V_{CC} | V |
| V_{OLT} | Output LOW voltage | $I_{OL} = 4 \text{ mA}, V_{CC} = \text{Min}$ | 0 | 0.4 | V |
| I_{OST} | Output short circuit current | $V_{OUT} = 0 \text{ V}^{[20]}$ | -20 | -100 | mA |
| I_{OZL} | High-Z output leakage current | | -20 | 20 | μA |
| LVTTL-compatible Inputs | | | | | |
| V_{IHT} | Input HIGH voltage | | 2.0 | $V_{CC} + 0.3$ | V |
| V_{ILT} | Input LOW voltage | | -0.5 | 0.8 | V |
| I_{IHT} | Input HIGH current | REFCLK Input, $V_{IN} = V_{CC}$ | - | 1.5 | mA |
| | | Other Inputs, $V_{IN} = V_{CC}$ | - | +40 | μA |
| I_{ILT} | Input LOW current | REFCLK Input, $V_{IN} = 0.0 \text{ V}$ | - | -1.5 | mA |
| | | Other Inputs, $V_{IN} = 0.0 \text{ V}$ | - | -40 | μA |
| I_{IHPDT} | Input HIGH current with internal pull-down | $V_{IN} = V_{CC}$ | - | +200 | μA |
| I_{ILPUT} | Input LOW current with internal pull-up | $V_{IN} = 0.0 \text{ V}$ | - | -200 | μA |
| LVDIFF Inputs: REFCLK\pm | | | | | |
| $V_{DIFF}^{[21]}$ | Input differential voltage | | 400 | V_{CC} | mV |
| V_{IHHP} | Highest input HIGH voltage | | 1.0 | V_{CC} | V |
| V_{ILLP} | Lowest input LOW voltage | | 0.0 | $V_{CC}/2$ | V |
| $V_{COM}^{[22]}$ | Common mode range | | 1.0 | $V_{CC} - 1.2\text{V}$ | V |
| 3-Level Inputs | | | | | |
| V_{IHH} | 3-level input HIGH voltage | $\text{Min} \leq V_{CC} \leq \text{Max}$ | $0.87 \times V_{CC}$ | V_{CC} | V |
| V_{IMM} | 3-level input MID voltage | $\text{Min} \leq V_{CC} \leq \text{Max}$ | $0.47 \times V_{CC}$ | $0.53 \times V_{CC}$ | V |
| V_{ILL} | 3-level input LOW voltage | $\text{Min} \leq V_{CC} \leq \text{Max}$ | 0.0 | $0.13 \times V_{CC}$ | V |
| I_{IHH} | Input HIGH current | $V_{IN} = V_{CC}$ | - | 200 | μA |
| I_{IMM} | Input MID current | $V_{IN} = V_{CC}/2$ | -50 | 50 | μA |
| I_{ILL} | Input LOW current | $V_{IN} = \text{GND}$ | - | -200 | μA |

Notes

20. Tested one output at a time, output shorted for less than one second, less than 10% duty cycle.

21. This is the minimum difference in voltage between the true and complement inputs required to ensure detection of a logic-1 or logic-0. A logic-1 exists when the true (+) input is more positive than the complement (-) input. A logic-0 exists when the complement (-) input is more positive than true (+) input.

22. The common mode range defines the allowable range of REFCLK+ and REFCLK- when REFCLK+ = REFCLK-. This marks the zero-crossing between the true and complement inputs as the signal switches between a logic-1 and a logic-0.

CYP15G0201DXB DC Electrical Characteristics (continued)

Over the Operating Range

| Parameter | Description | Test Conditions | Min | Max | Unit |
|---|--|--|------------------------|------------------------|------|
| Differential CML Serial Outputs: OUTA1±, OUTA2±, OUTB1±, OUTB2± | | | | | |
| V _{OHC} | Output HIGH voltage (V _{CC} referenced) | 100 Ω differential load | V _{CC} - 0.5 | V _{CC} - 0.2 | V |
| | | 150 Ω differential load | V _{CC} - 0.5 | V _{CC} - 0.2 | V |
| V _{OLC} | Output LOW voltage (V _{CC} referenced) | 100 Ω differential load | V _{CC} - 1.4 | V _{CC} - 0.7 | V |
| | | 150 Ω differential load | V _{CC} - 1.4 | V _{CC} - 0.7 | V |
| V _{ODIF} | Output differential voltage (OUT+) - (OUT-) | 100 Ω differential load | 450 | 900 | mV |
| | | 150 Ω differential load | 560 | 1000 | mV |
| Differential Serial Line Receiver Inputs: INA1±, INA2±, INB1±, INB2± | | | | | |
| V _{DIFFS} ^[21] | Input differential voltage (IN+) - (IN-) | | 100 | 1200 | mV |
| V _{IHE} | Highest input HIGH voltage | | - | V _{CC} | V |
| V _{ILE} | Lowest input LOW voltage | | V _{CC} - 2.0 | - | V |
| I _{IHE} | Input HIGH current | V _{IN} = V _{IHE} Max | - | 1350 | μA |
| I _{ILE} | Input LOW current | V _{IN} = V _{ILE} Min | -700 | - | μA |
| V _{COM} ^[23, 24] | Common mode input range | | V _{CC} - 1.95 | V _{CC} - 0.05 | V |

| Power Supply | | | Typ ^[23] | Max ^[22] | Unit |
|-----------------|--|------------|---------------------|---------------------|------|
| I _{CC} | Power supply current
REFCLK = Max | Commercial | 570 | 700 | mA |
| | | Industrial | | 710 | mA |
| I _{CC} | Power supply current
REFCLK = 125 MHz | Commercial | 570 | 700 | mA |
| | | Industrial | | 710 | mA |

AC Test Loads and Waveforms

(a) LVTTTL Output Test Load^[27]

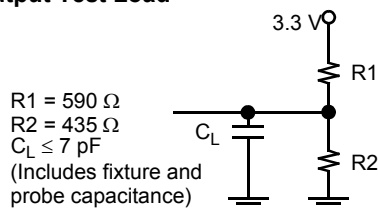

(b) CML Output Test Load^[27]

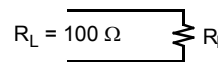

(c) LVTTTL Input Test Waveform^[28]

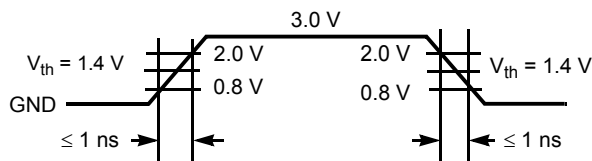

(d) CML/LVPECL Input Test Waveform

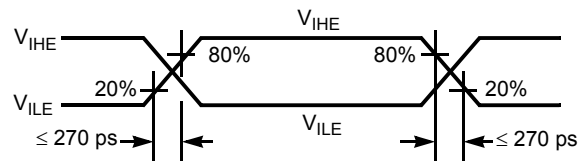

Notes

- 23. The common mode range defines the allowable range of INPUT+ and INPUT- when INPUT+ = INPUT-. This marks the zero-crossing between the true and complement inputs as the signal switches between a logic-1 and a logic-0.
- 24. Not applicable for AC-coupled interfaces. For AC-coupled interfaces, V_{DIFFS} requirement still needs to be satisfied.
- 25. Maximum I_{CC} is measured with V_{CC} = MAX, RXCKSEL = LOW, with all TX and RX channels and Serial Line Drivers enabled, sending a continuous alternating 01 pattern to the associated receive channel, and outputs unloaded.
- 26. Typical I_{CC} is measured under similar conditions except with V_{CC} = 3.3 V, T_A = 25 °C, RXCKSEL = LOW, with all TX and RX channels enabled and one Serial Line Driver per transmit channel sending a continuous alternating 01 pattern to the associated receive channel. The redundant outputs on each channel are powered down and the parallel outputs are unloaded.
- 27. Cypress uses constant current (ATE) load configurations and forcing functions. This figure is for reference only. 5 pF differential load reflects tester capacitance, and is recommended at low data rates only.
- 28. The LVTTTL switching threshold is 1.4 V. All timing references are made relative to the point where the signal edges crosses this threshold voltage.

CYP15G0201DXB AC Characteristics

Over the Operating Range

| Parameter | Description | Min | Max | Unit |
|---|---|----------------------|--------|------|
| Transmitter LVTTTL Switching Characteristics | | | | |
| f_{TS} | TXCLKx Clock Frequency | 19.5 | 150 | MHz |
| t_{TXCLK} | TXCLKx Period | 6.66 | 51.28 | ns |
| $t_{TXCLKH}^{[29]}$ | TXCLKx HIGH Time | 2.2 | – | ns |
| $t_{TXCLKL}^{[29]}$ | TXCLKx LOW Time | 2.2 | – | ns |
| $t_{TXCLKR}^{[29, 30, 31]}$ | TXCLKx Rise Time | 0.2 | 1.7 | ns |
| $t_{TXCLKF}^{[29, 30, 31]}$ | TXCLKx Fall Time | 0.2 | 1.7 | ns |
| t_{TXDS} | Transmit Data Setup Time to TXCLKx \uparrow (TXCKSEL \neq LOW) | 1.7 | – | ns |
| t_{TXDH} | Transmit Data Hold Time from TXCLKx \uparrow (TXCKSEL \neq LOW) | 0.8 | – | ns |
| f_{TOS} | TXCLKO Clock Frequency = 1x or 2x REFCLK Frequency | 19.5 | 150 | MHz |
| t_{TXCLKO} | TXCLKO Period | 6.66 | 51.28 | ns |
| $t_{TXCLKOD+}$ | TXCLKO+ Duty Cycle with 60% HIGH time | –1.0 | +0.5 | ns |
| $t_{TXCLKOD-}$ | TXCLKO– Duty Cycle with 40% HIGH time | –0.5 | +1.0 | ns |
| Receiver LVTTTL Switching Characteristics | | | | |
| f_{RS} | RXCLKx Clock Output Frequency | 9.75 | 150 | MHz |
| t_{RXCLKP} | RXCLKx Period | 6.66 | 102.56 | ns |
| t_{RXCLKH} | RXCLKx HIGH Time (RXRATE = LOW) | 2.33 ^[29] | 26.64 | ns |
| | RXCLKx HIGH Time (RXRATE = HIGH) | 5.66 | 52.28 | ns |
| t_{RXCLKL} | RXCLKx LOW Time (RXRATE = LOW) | 2.33 ^[29] | 26.64 | ns |
| | RXCLKx LOW Time (RXRATE = HIGH) | 5.66 | 52.28 | ns |
| t_{RXCLKD} | RXCLKx Duty Cycle centered at 50% | –1.0 | +1.0 | ns |
| $t_{RXCLKR}^{[29]}$ | RXCLKx Rise Time | 0.3 | 1.2 | ns |
| $t_{RXCLKF}^{[29]}$ | RXCLKx Fall Time | 0.3 | 1.2 | ns |
| $t_{RXDV-}^{[32]}$ | Status and Data Valid Time to RXCLKx (RXCKSEL = HIGH or MID) | 5UI – 1.5 | – | ns |
| | Status and Data Valid Time to RXCLKx (Half Rate Recovered Clock) | 5UI – 1.0 | – | ns |
| $t_{RXDV+}^{[32]}$ | Status and Data Valid Time From RXCLKx (RXCKSEL = HIGH or MID) | 5UI – 1.8 | – | ns |
| | Status and Data Valid Time From RXCLKx (Half Rate Recovered Clock) | 5UI – 2.3 | – | ns |
| REFCLK Switching Characteristics | | | | |
| Over the Operating Range | | | | |
| f_{REF} | REFCLK Clock Frequency | 19.5 | 150 | MHz |
| t_{REFCLK} | REFCLK Period | 6.66 | 51.28 | ns |
| t_{REFH} | REFCLK HIGH Time (TXRATE = HIGH) | 5.9 | – | ns |
| | REFCLK HIGH Time (TXRATE = LOW) | 2.9 ^[29] | – | ns |
| t_{REFL} | REFCLK LOW Time (TXRATE = HIGH) | 5.9 | – | ns |
| | REFCLK LOW Time (TXRATE = LOW) | 2.9 ^[29] | – | ns |

Notes

29. Tested initially and after any design or process changes that may affect these parameters, but not 100% tested.

30. The ratio of rise time to falling time must not vary by greater than 2:1.

31. For an operating frequency, neither rise or fall specification can be greater than 20% of the clock-cycle period or the datasheet maximum time.

32. Parallel data output specifications are only valid if all inputs or outputs are loaded with similar DC and AC loads.

CYP15G0201DXB AC Characteristics (continued)

Over the Operating Range

| Parameter | Description | Min | Max | Unit | |
|---|---|---|-------|--------------------|----|
| $t_{REFD}^{[33]}$ | REFCLK duty cycle | 30 | 70 | % | |
| $t_{REFR}^{[29, 30, 31]}$ | REFCLK rise time (20% to 80%) | – | 2 | ns | |
| $t_{REFF}^{[29, 30, 31]}$ | REFCLK fall time (20% to 80%) | – | 2 | ns | |
| t_{TREFDS} | Transmit data setup time to REFCLK (TXCKSEL = LOW) | 1.7 | – | ns | |
| t_{TREFDH} | Transmit data hold time from REFCLK (TXCKSEL = LOW) | 0.8 | – | ns | |
| $t_{RREFDA}^{[34]}$ | Receive data access time from REFCLK (RXCKSEL = LOW) | – | 9.5 | ns | |
| t_{RREFDV} | Receive data valid time from REFCLK (RXCKSEL = LOW) | 2.5 | – | ns | |
| $t_{REFADV-}$ | Received data valid time to RXCLKA (RXCKSEL = LOW) | 10UI – 4.7 | – | ns | |
| $t_{REFADV+}$ | Received data valid time from RXCLKA (RXCKSEL = LOW) | 0.5 | – | ns | |
| $t_{REFCDV-}$ | Received data valid time to RXCLKC (RXCKSEL = LOW) | 10UI – 4.3 | – | ns | |
| $t_{REFCDV+}$ | Received data valid time from RXCLKC (RXCKSEL = LOW) | –0.2 | – | ns | |
| $t_{REFRX}^{[29, 31]}$ | REFCLK frequency referenced to extracted received clock frequency | –0.02 | +0.02 | % | |
| Transmit Serial Outputs and TX PLL Characteristics | | | | | |
| t_B | Bit Time | | 5100 | 666 | ps |
| $t_{RISE}^{[29]}$ | CML Output Rise Time 20% to 80% (CML test load) | SPDSEL = HIGH | 60 | 270 | ps |
| | | SPDSEL = MID | 100 | 500 | ps |
| | | SPDSEL = LOW | 180 | 1000 | ps |
| $t_{FALL}^{[29]}$ | CML Output Fall Time 80% to 20% (CML test load) | SPDSEL = HIGH | 60 | 270 | ps |
| | | SPDSEL = MID | 100 | 500 | ps |
| | | SPDSEL = LOW | 180 | 1000 | ps |
| $t_{DJ}^{[29, 35, 37]}$ | Deterministic Jitter (peak-peak) | IEEE 802.3z | – | 25 | ps |
| $t_{RJ}^{[29, 36, 37]}$ | Random jitter (σ) | IEEE 802.3z | – | 11 | ps |
| t_{TXLOCK} | Transmit PLL lock to REFCLK | – | 200 | us | |
| Receive Serial Inputs and CDR PLL Characteristics | | | | | |
| t_{RXLOCK} | Receive PLL lock to input data stream (cold start) | – | 376K | UI ^[39] | |
| | Receive PLL lock to input data stream | – | 376K | UI | |
| $t_{RXUNLOCK}$ | Receive PLL unlock rate | – | 46 | UI | |
| $t_{JTOL}^{[37]}$ | Total jitter tolerance | IEEE 802.3z ^[38] | 600 | – | ps |
| $t_{DJTOL}^{[37]}$ | Deterministic jitter tolerance | IEEE 802.3z ^[38] | 370 | – | ps |
| Capacitance^[29] | | | | | |
| Parameter | Description | Test Conditions | Max | Unit | |
| C_{INTTL} | TTL Input Capacitance | $T_A = 25^\circ\text{C}$, $f_0 = 1\text{ MHz}$, $V_{CC} = 3.3\text{ V}$ | 7 | pF | |
| C_{INPECL} | PECL input Capacitance | $T_A = 25^\circ\text{C}$, $f_0 = 1\text{ MHz}$, $V_{CC} = 3.3\text{ V}$ | 4 | pF | |

Notes

33. The duty cycle specification is a simultaneous condition with the t_{REFH} and t_{REFL} parameters. This means that at faster character rates the REFCLK duty cycle cannot be as large as 30% to 70%.
34. Since this timing parameter is greater than the minimum time period of REFCLK it sets an upper limit to the frequency in which REFCLKx can be used to clock the receive data out of the output register. For predictable timing, users can use this parameter only if REFCLK period is greater than sum of t_{RREFDA} and setup time of the upstream device. When this condition is not true, RXCLKC± or RXCLKA± (a buffered or delayed version of REFCLK when RXCKSELx = LOW) could be used to clock the receive data out of the device.
35. While sending continuous K28.5 s, outputs loaded to a balanced 100 Ω load, measured at the cross point of the differential outputs over the operating range.
36. While sending continuous K28.7 s, after 100,000 samples measured at the cross point of differential outputs, time referenced to REFCLK input, over the operating range.
37. Total jitter is calculated at an assumed BER of 1E–12. Hence: Total Jitter (t_j) = $(t_{RJ} \times 14) + t_{DJ}$.
38. Also meets all Jitter Generation and Jitter Tolerance requirements as specified by CPRI, ESCON, FICON, Fibre Channel and DVB-ASI.
39. Receiver UI (Unit Interval) is calculated as $1/(f_{REF} \times 20)$ (when RXRATE = HIGH) or $1/(f_{REF} \times 10)$ (when RXRATE = LOW) if no data is being received, or $1/(f_{REF} \times 20)$ (when RXRATE = HIGH) or $1/(f_{REF} \times 10)$ (when RXRATE = LOW) of the remote transmitter if data is being received. In an operating link this is equivalent to t_B .

Switching Waveforms

For CYP15G0201DXB HOTLink II Transmitter

Transmit Interface Write Timing TXCKSEL ≠ LOW

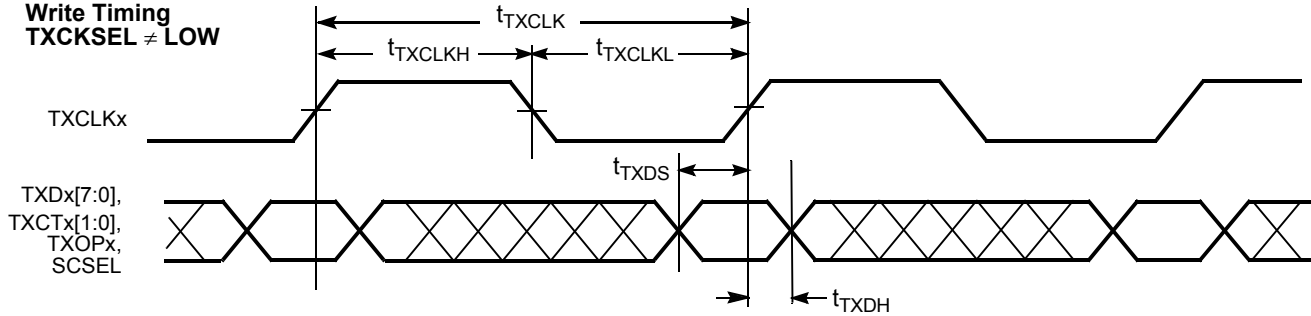

Transmit Interface Write Timing TXCKSEL = LOW TXRATE = LOW

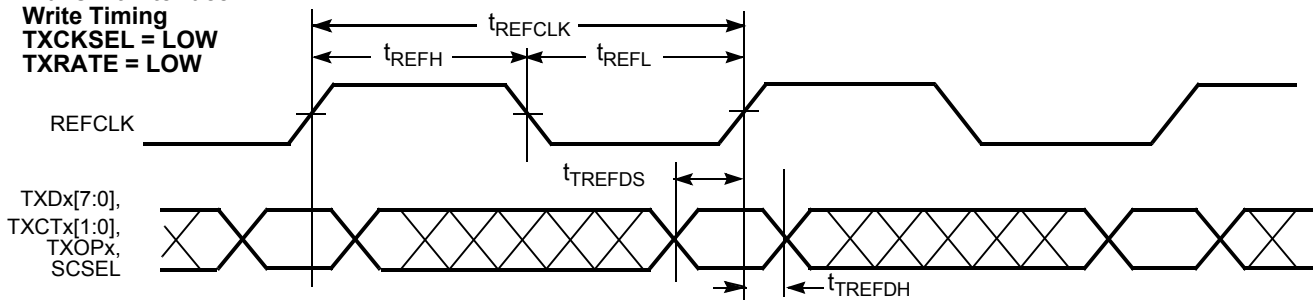

Transmit Interface Write Timing TXCKSEL = LOW TXRATE = HIGH

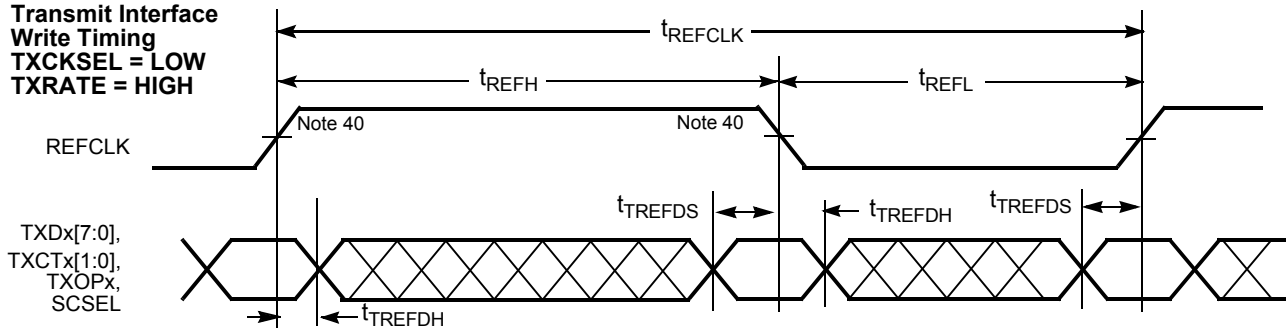

Transmit Interface TXCLKO Timing TXCKSEL = LOW TXRATE = HIGH

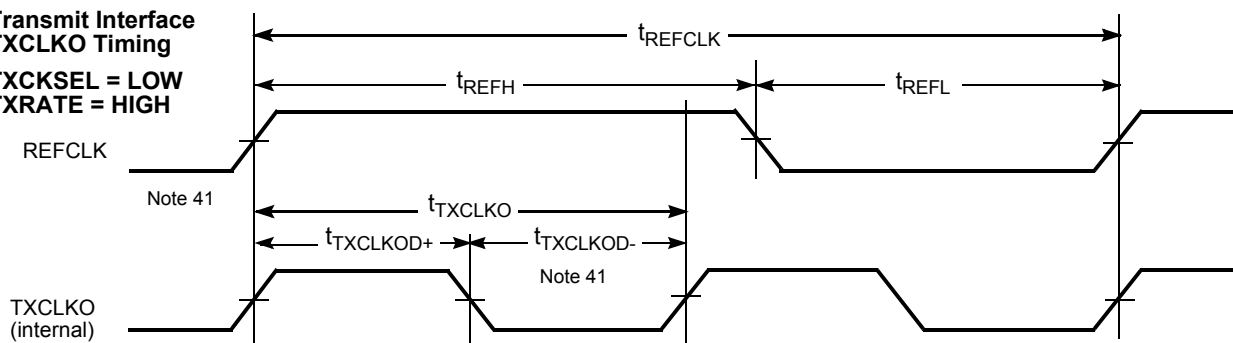

Notes

40. When REFCLK is configured for half-rate operation (TXRATE = HIGH) and data is captured using REFCLK instead of a TXCLKx clock (TXCKSEL = LOW), data is captured using both the rising and falling edges of REFCLK.
41. The TXCLKO output is at twice the rate of REFCLK when TXRATE = HIGH and same rate as REFCLK when TXRATE = LOW. TXCLKO does not follow the duty cycle of REFCLK.
42. The TXCLKO output remains at the character rate regardless of the state of TXRATE and does not follow the duty cycle of REFCLK.

Switching Waveforms (continued)

For CYP15G0201DXB HOTLink II Transmitter

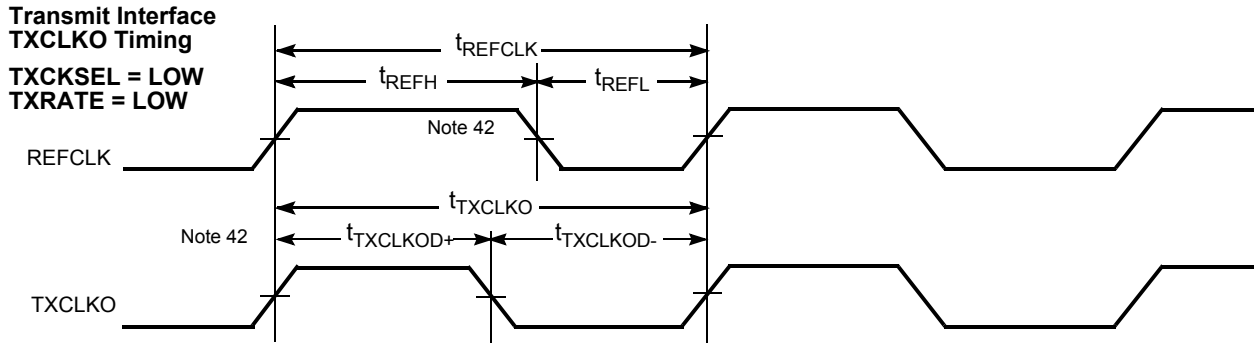

Switching Waveforms

For CYP15G0201DXB HOTLink II Receiver

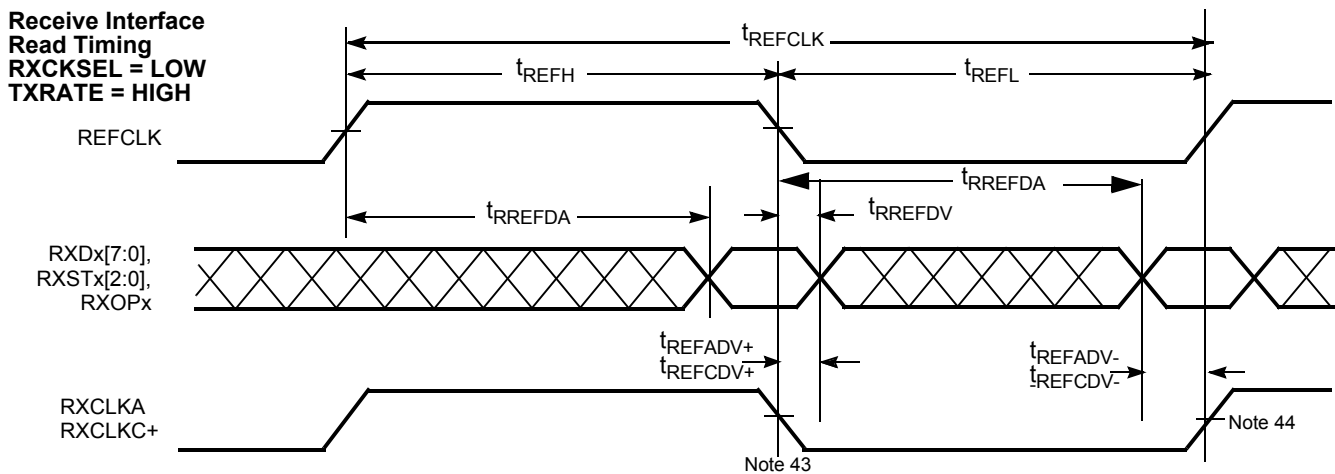
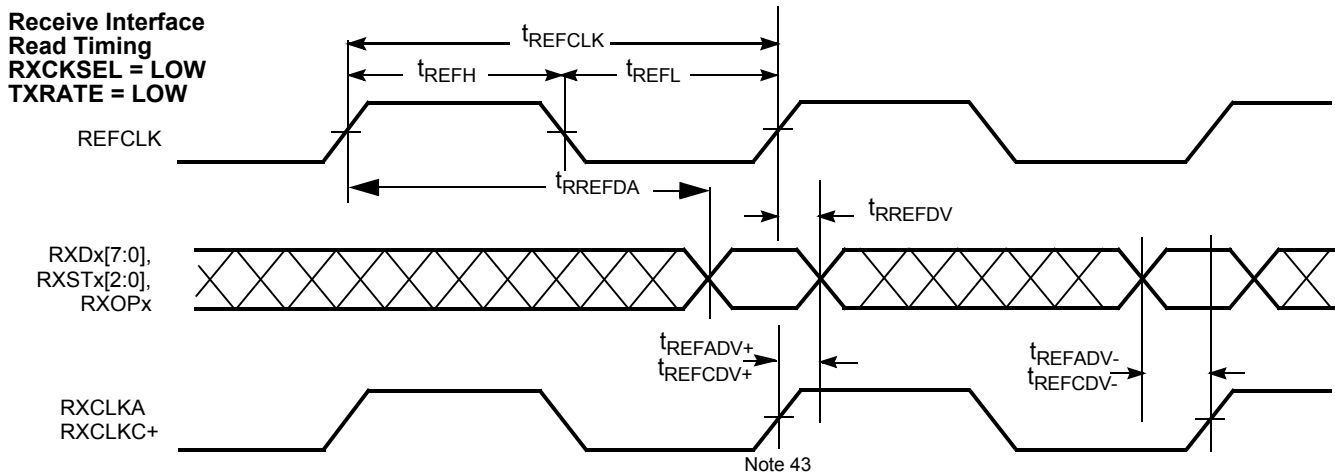

Notes

43. RXCLKA is delayed in phase from REFCLK, and are different in phase from each other.

44. When operated with a half-rate REFCLK, the setup and hold specifications for data relative to RXCLKA are relative to both rising and falling edges of the respective clock output.

Switching Waveforms (continued)

For CYP15G0201DXB HOTLink II Receiver

**Receive Interface
Read Timing
RXCKSEL = HIGH or MID
RXRATE = LOW**

**Receive Interface
Read Timing
RXCKSEL = HIGH or MID
RXRATE = HIGH**

Table 21. Package Coordinate Signal Allocation

| Ball ID | Signal Name | Signal Type | Ball ID | Signal Name | Signal Type | Ball ID | Signal Name | Signal Type |
|---------|-----------------|----------------|---------|-----------------|----------------|---------|-----------------|----------------|
| A1 | V _{CC} | POWER | C5 | RXLE | LVTTTL IN PU | E9 | TXOPB | LVTTTL IN PU |
| A2 | INA2+ | CML IN | C6 | RXRATE | LVTTTL IN PD | E10 | TXPERB | LVTTTL OUT |
| A3 | OUTA2- | CML OUT | C7 | GND | GROUND | E11 | TXCKSEL | 3-LEVEL SEL |
| A4 | V _{CC} | POWER | C8 | GND | GROUND | E12 | RXCKSEL | 3-LEVEL SEL |
| A5 | INA1+ | CML IN | C9 | SPDSEL | 3-LEVEL SEL | E13 | TRSTZ | LVTTTL IN PU |
| A6 | OUTA1- | CML OUT | C10 | PARCTL | 3-LEVEL SEL | E14 | TMS | LVTTTL IN PU |
| A7 | V _{CC} | POWER | C11 | RFMODE | 3-LEVEL SEL | F1 | DECMODE | 3-LEVEL SEL |
| A8 | V _{CC} | POWER | C12 | V _{CC} | POWER | F2 | OELE | LVTTTL IN PU |
| A9 | INB2+ | CML IN | C13 | SDASEL | 3-LEVEL SEL | F3 | RXCLKC+ | LVTTTL 3-S OUT |
| A10 | OUTB2- | CML OUT | C14 | BOE[2] | LVTTTL IN PU | F4 | RXSTA[2] | LVTTTL OUT |
| A11 | V _{CC} | POWER | D1 | V _{CC} | POWER | F5 | RXSTA[1] | LVTTTL OUT |
| A12 | INB1+ | CML IN | D2 | V _{CC} | POWER | F6 | GND | GROUND |
| A13 | OUTB1- | CML OUT | D3 | NC | Not Connected | F7 | GND | GROUND |
| A14 | V _{CC} | POWER | D4 | TXRATE | LVTTTL IN PD | F8 | GND | GROUND |
| B1 | TDO | LVTTTL 3-S OUT | D5 | RXMODE[1] | 3-LEVEL SEL | F9 | GND | GROUND |
| B2 | INA2- | CML IN | D6 | RXMODE[0] | 3-LEVEL SEL | F10 | TXDB[4] | LVTTTL IN |
| B3 | OUTA2+ | CML OUT | D7 | GND | GROUND | F11 | TXDB[3] | LVTTTL IN |
| B4 | V _{CC} | POWER | D8 | GND | GROUND | F12 | TXDB[2] | LVTTTL IN |
| B5 | INA1- | CML IN | D9 | TCLK | LVTTTL IN PD | F13 | TXDB[1] | LVTTTL IN |
| B6 | OUTA1+ | CML OUT | D10 | TDI | LVTTTL IN PU | F14 | TXDB[0] | LVTTTL IN |
| B7 | NC | Not Connected | D11 | INSELB | LVTTTL IN | G1 | V _{CC} | POWER |
| B8 | NC | Not Connected | D12 | INSELA | LVTTTL IN | G2 | NC | Not Connected |
| B9 | INB2- | CML IN | D13 | V _{CC} | POWER | G3 | GND | GROUND |
| B10 | OUTB2+ | CML OUT | D14 | V _{CC} | POWER | G4 | GND | GROUND |
| B11 | V _{CC} | POWER | E1 | BISTLE | LVTTTL IN PU | G5 | GND | GROUND |
| B12 | INB1- | CML IN | E2 | FRAMCHAR | 3-LEVEL SEL | G6 | GND | GROUND |
| B13 | OUTB1+ | CML OUT | E3 | TXMODE[1] | 3-LEVEL SEL | G7 | GND | GROUND |
| B14 | BOE[3] | LVTTTL IN PU | E4 | TXMODE[0] | 3-LEVEL SEL | G8 | GND | GROUND |
| C1 | NC | Not Connected | E5 | BOE[0] | LVTTTL IN PU | G9 | GND | GROUND |
| C2 | RFEN | LVTTTL IN PD | E6 | BOE[1] | LVTTTL IN PU | G10 | GND | GROUND |
| C3 | V _{CC} | POWER | E7 | GND | GROUND | G11 | GND | GROUND |
| C4 | LPEN | LVTTTL IN PD | E8 | GND | GROUND | G12 | GND | GROUND |
| G13 | NC | Not Connected | K4 | RXDA[6] | LVTTTL OUT | M9 | TXRSTn | LVTTTL IN PU |
| G14 | V _{CC} | POWER | K5 | TXDA[4] | LVTTTL OUT | M10 | NC | Not Connected |
| H1 | V _{CC} | POWER | K6 | TXCLKA | LVTTTL IN PD | M11 | RXSTB[0] | LVTTTL OUT |
| H2 | NC | Not Connected | K7 | GND | GROUND | M12 | V _{CC} | POWER |
| H3 | GND | GROUND | K8 | GND | GROUND | M13 | RXDB[5] | LVTTTL OUT |
| H4 | GND | GROUND | K9 | NC | Not Connected | M14 | RXDB[6] | LVTTTL OUT |
| H5 | GND | GROUND | K10 | RXOPB | LVTTTL 3-S OUT | N1 | RXCLKA+ | LVTTTL I/O PD |
| H6 | GND | GROUND | K11 | RXCLKB+ | LVTTTL I/O PD | N2 | TXCTA[0] | LVTTTL IN |
| H7 | GND | GROUND | K12 | RXCLKB- | LVTTTL I/O PD | N3 | TXDA[6] | LVTTTL IN |
| H8 | GND | GROUND | K13 | LFIB | LVTTTL OUT | N4 | V _{CC} | POWER |

Table 21. Package Coordinate Signal Allocation (continued)

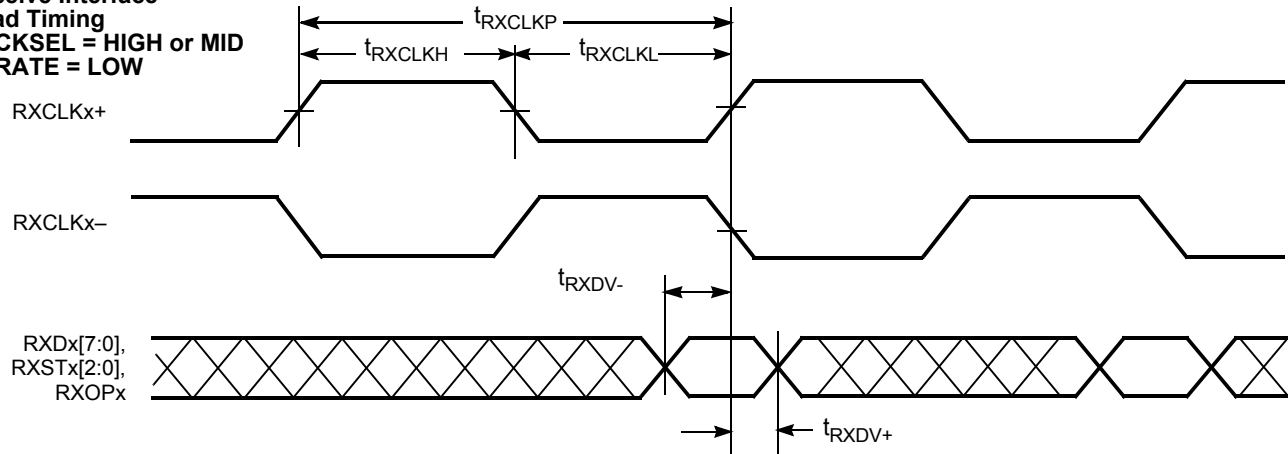
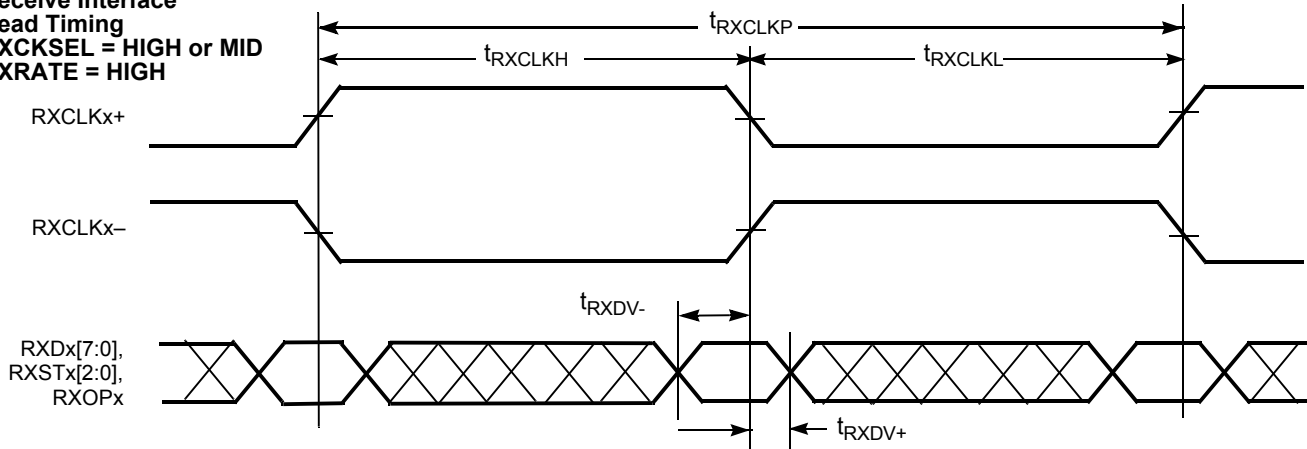
| Ball ID | Signal Name | Signal Type | Ball ID | Signal Name | Signal Type | Ball ID | Signal Name | Signal Type |
|---------|-----------------|----------------|---------|-----------------|---------------|---------|-----------------|---------------|
| H9 | GND | GROUND | K14 | TXCLKB | LVTTTL IN PD | N5 | TXDA[1] | LVTTTL IN |
| H10 | GND | GROUND | L1 | V _{CC} | POWER | N6 | NC | Not Connected |
| H11 | GND | GROUND | L2 | V _{CC} | POWER | N7 | NC | Not Connected |
| H12 | GND | GROUND | L3 | RXDA[7] | LVTTTL OUT | N8 | NC | Not Connected |
| H13 | NC | Not Connected | L4 | LFIA | LVTTTL OUT | N9 | REFCLK- | PECL IN |
| H14 | V _{CC} | POWER | L5 | TXDA[3] | LVTTTL IN | N10 | TXCLKO+ | LVTTTL OUT |
| J1 | RXSTA[0] | LVTTTL OUT | L6 | TXOPA | LVTTTL IN | N11 | V _{CC} | POWER |
| J2 | RXOPA | LVTTTL 3-S OUT | L7 | GND | GROUND | N12 | RXDB[2] | LVTTTL OUT |
| J3 | RXDA[0] | LVTTTL OUT | L8 | GND | GROUND | N13 | RXDB[3] | LVTTTL OUT |
| J4 | RXDA[1] | LVTTTL OUT | L9 | SCSEL | LVTTTL IN | N14 | RXDB[4] | LVTTTL OUT |
| J5 | RXDA[2] | LVTTTL OUT | L10 | RXSTB[2] | LVTTTL OUT | P1 | V _{CC} | POWER |
| J6 | GND | GROUND | L11 | RXSTB[1] | LVTTTL OUT | P2 | TXDA[7] | LVTTTL IN |
| J7 | GND | GROUND | L12 | RXDB[7] | LVTTTL OUT | P3 | TXDA[5] | LVTTTL IN |
| J8 | GND | GROUND | L13 | V _{CC} | POWER | P4 | V _{CC} | POWER |
| J9 | GND | GROUND | L14 | V _{CC} | POWER | P5 | TXDA[0] | LVTTTL IN |
| J10 | TXCTB[0] | LVTTTL IN | M1 | RXCLKA- | LVTTTL I/O PD | P6 | NC | Not Connected |
| J11 | TXCTB[1] | LVTTTL IN | M2 | TXCTA[1] | LVTTTL IN | P7 | V _{CC} | POWER |
| J12 | TXDB[7] | LVTTTL IN | M3 | V _{CC} | POWER | P8 | V _{CC} | POWER |
| J13 | TXDB[6] | LVTTTL IN | M4 | NC | Not Connected | P9 | REFCLK+ | PECL IN |
| J14 | TXDB[5] | LVTTTL IN | M5 | TXDA[2] | LVTTTL IN | P10 | TXCLKO- | LVTTTL OUT |
| K1 | RXDA[3] | LVTTTL OUT | M6 | TXPERA | LVTTTL OUT | P11 | V _{CC} | POWER |
| K2 | RXDA[4] | LVTTTL OUT | M7 | GND | GROUND | P12 | RXDB[1] | LVTTTL OUT |
| K3 | RXDA[5] | LVTTTL OUT | M8 | GND | GROUND | P13 | RXDB[0] | LVTTTL OUT |
| P14 | V _{CC} | POWER | | | | | | |

X3.230 Codes and Notation Conventions

Information to be transmitted over a serial link is encoded eight bits at a time into a 10-bit transmission character and then sent serially, bit by bit. Information received over a serial link is collected ten bits at a time, and those transmission characters that are used for data (data characters) are decoded into the correct eight-bit codes. The 10-bit transmission code supports all 256 8-bit combinations. Some of the remaining transmission characters (special characters) are used for functions other than data transmission.

The primary rationale for use of a transmission code is to improve the transmission characteristics of a serial link. The encoding defined by the transmission code ensures that sufficient transitions are present in the serial bit stream to make clock recovery possible at the receiver. Such encoding also greatly increases the likelihood of detecting any single or multiple bit errors that may occur during transmission and reception of information. In addition, some special characters of the transmission code selected by fibre channel standard contain a distinct and easily recognizable bit pattern (the special character COMMA) that assists a receiver in achieving character alignment on the incoming bit stream.

Notation Conventions

The documentation for the 8B/10B transmission code uses letter notation for the bits in an 8-bit byte. Fibre Channel Standard notation uses a bit notation of A, B, C, D, E, F, G, H for the 8-bit byte for the raw 8-bit data, and the letters a, b, c, d, e, i, f, g, h, j for encoded 10-bit data. There is a correspondence between bit A and bit a, B and b, C and c, D and d, E and e, F and f, G and g, and H and h. Bits i and j are derived, respectively, from (A,B,C,D,E) and (F,G,H).

The bit labeled A in the description of the 8B/10B transmission code corresponds to bit 0 in the numbering scheme of the FC-2 specification, B corresponds to bit 1, as shown in the following.

FC-2 bit designation—76543210
 HOTLink D/Q designation—76543210
 8B/10B bit designation—HGFEDCBA

To clarify this correspondence, the following example shows the conversion from an FC-2 valid data byte to a transmission character (using 8B/10B transmission code notation)

```
FC-2  45
      Bits: 7654 3210
           0100 0101
```

Converted to 8B/10B notation (note carefully that the order of bits is reversed):

```
Data Byte Name  D5.2
      Bits: ABCDEFGH
           10100 010
```

Translated to a transmission Character in the 8B/10B Transmission Code:

```
Bits: abcdeifghj
      1010010101
```

Each valid transmission character of the 8B/10B transmission code has been given a name using the following convention: cxx.y, where c is used to show whether the transmission character is a data character (c is set to D, and SC/D = LOW) or a special character (c is set to K, and SC/D = HIGH). When c is

set to D, xx is the decimal value of the binary number composed of the bits E, D, C, B, and A in that order, and the y is the decimal value of the binary number composed of the bits H, G, and F in that order. When c is set to K, xx and y are derived by comparing the encoded bit patterns of the special character to those patterns derived from encoded valid data bytes and selecting the names of the patterns most similar to the encoded bit patterns of the special character.

Under the above conventions, the transmission character used for previous examples, is referred to by the name D5.2. The special character K29.7 is so named because the first six bits (abcdei) of this character make up a bit pattern similar to that resulting from the encoding of the unencoded 11101 pattern (29), and because the second four bits (fghj) make up a bit pattern similar to that resulting from the encoding of the unencoded 111 pattern (7). This definition of the 10-bit transmission code is based on the following references.

A.X. Widmer and P.A. Franaszek. "A DC-Balanced, Partitioned-Block, 8B/10B Transmission Code" *IBM Journal of Research and Development*, 27, No. 5: 440–451 (September, 1983).

U.S. Patent 4,486,739. Peter A. Franaszek and Albert X. Widmer. "Byte-Oriented DC Balanced (0.4) 8B/10B Partitioned Block Transmission Code" (December 4, 1984).

Fibre Channel Physical and Signaling Interface (ANSI X3.230–1994 ANSI FC–PH Standard).

IBM Enterprise Systems Architecture/390 ESCON I/O Interface (document number SA22–7202).

8B/10B Transmission Code

The following information describes how the tables shall be used for both generating valid transmission characters (encoding) and checking the validity of received transmission characters (decoding). It also specifies the ordering rules to be followed when transmitting the bits within a character and the characters within any higher-level constructs specified by the standard.

Transmission Order

Within the definition of the 8B/10B transmission code, the bit positions of the transmission characters are labeled a, b, c, d, e, i, f, g, h, j. Bit "a" is transmitted first followed by bits b, c, d, e, i, f, g, h, and j in that order.

Note that bit i is transmitted between bit e and bit f, rather than in alphabetical order.

Valid and Invalid Transmission Characters

The following tables define the valid data characters and valid special characters (K characters), respectively. The tables are used for both generating valid transmission characters (encoding) and checking the validity of received transmission characters (decoding). In the tables, each valid-data-byte or special-character-code entry has two columns that represent two (not necessarily different) transmission characters. The two columns correspond to the current value of the running disparity ("Current RD–" or "Current RD+"). Running disparity is a binary parameter with either a negative (–) or positive (+) value.

After powering on, the transmitter may assume either a positive or negative value for its initial running disparity. Upon transmission of any transmission character, the transmitter selects the proper version of the transmission character based

on the current running disparity value, and the transmitter calculates a new value for its running disparity based on the contents of the transmitted character. Special character codes C1.7 and C2.7 can be used to force the transmission of a specific special character with a specific running disparity as required for some special sequences in X3.230.

After powering on, the receiver may assume either a positive or negative value for its initial running disparity. Upon reception of any transmission character, the receiver decides whether the transmission character is valid or invalid according to the following rules and tables and calculates a new value for its running disparity based on the contents of the received character.

The following rules for running disparity are used to calculate the new running-disparity value for transmission characters that have been transmitted and that have been received.

Running disparity for a transmission character is calculated from sub-blocks, where the first six bits (abcdei) form one sub-block and the second four bits (fghj) form the other sub-block. Running disparity at the beginning of the 6-bit sub-block is the running disparity at the end of the previous transmission character. Running disparity at the beginning of the 4-bit sub-block is the running disparity at the end of the 6-bit sub-block. Running disparity at the end of the transmission character is the running disparity at the end of the 4-bit sub-block.

Running disparity for the sub-blocks is calculated as follows:

1. Running disparity at the end of any sub-block is positive if the sub-block contains more ones than zeros. It is also positive at the end of the 6-bit sub-block if the 6-bit sub-block is 000111, and it is positive at the end of the 4-bit sub-block if the 4-bit sub-block is 0011
2. Running disparity at the end of any sub-block is negative if the sub-block contains more zeros than ones. It is also negative at the end of the 6-bit sub-block if the 6-bit sub-block is 111000, and it is negative at the end of the 4-bit sub-block if the 4-bit sub-block is 1100
3. Otherwise, running disparity at the end of the sub-block is the same as at the beginning of the sub-block

Use of the Tables for Generating Transmission Characters

The appropriate entry in [Table 24 on page 43](#) for the valid data byte or [Table 25 on page 47](#) for the special character byte for which transmission character is to be generated (encoded). The current value of the transmitter's running disparity is used to select the transmission character from its corresponding column. For each transmission character transmitted, a new value of the running disparity is calculated. This new value shall be used as

the transmitter's current running disparity for the next valid data byte or special character byte to be encoded and transmitted. [Table 22](#) shows naming notations and examples of valid transmission characters.

Use of the Tables for Checking the Validity of Received Transmission Characters

The column corresponding to the current value of the receiver's running disparity is searched for the received transmission character. If the received transmission character is found in the proper column, then the transmission character is valid and the associated data byte or special character code is determined (decoded). If the received transmission character is not found in that column, then the transmission character is invalid. This is called a code violation. Independent of the transmission character's validity, the received transmission character is used to calculate a new value of running disparity. The new value is used as the receiver's current running disparity for the next received transmission character.

Table 22. Valid Transmission Characters

| Byte Name | Data | | Hex Value |
|-----------|-------------------------------------|--------|-----------|
| | D _{IN} or Q _{OUT} | | |
| | 765 | 43210 | |
| D0.0 | 000 | 00000 | 00 |
| D1.0 | 000 | 00001 | 01 |
| D2.0 | 000 | 00010 | 02 |
| .g | . | . | . |
| . | . | . | . |
| D5.2 | 010 | 000101 | 45 |
| . | . | . | . |
| . | . | . | . |
| D30.7 | 111 | 11110 | FE |
| D31.7 | 111 | 11111 | FF |

Detection of a code violation does not necessarily show that the transmission character in which the code violation was detected is in error. Code violations may result from a prior error that altered the running disparity of the bit stream which did not result in a detectable error at the Transmission Character in which the error occurred. [Table 23](#) shows an example of this behavior.

Table 23. Code Violations Resulting from Prior Errors

| | RD | Character | RD | Character | RD | Character | RD |
|----------------------------|----|-------------|----|-------------|----|----------------|----|
| Transmitted data character | - | D21.1 | - | D10.2 | - | D23.5 | + |
| Transmitted bit stream | - | 101010 1001 | - | 010101 0101 | - | 111010 1010 | + |
| Bit stream after error | - | 101010 1011 | + | 010101 0101 | + | 111010 1010 | + |
| Decoded data character | - | D21.0 | + | D10.2 | + | Code Violation | + |

Table 24. Valid Data Characters (TXCTx[0] = 0, RXSTx[2:0] = 000)

| Data Byte Name | Bits | Current RD- | Current RD+ | Data Byte Name | Bits | Current RD- | Current RD+ |
|----------------|-----------|-------------|-------------|----------------|-----------|-------------|-------------|
| | HGF EDCBA | abcdei fghj | abcdei fghj | | HGF EDCBA | abcdei fghj | abcdei fghj |
| D0.0 | 000 00000 | 100111 0100 | 011000 1011 | D0.1 | 001 00000 | 100111 1001 | 011000 1001 |
| D1.0 | 000 00001 | 011101 0100 | 100010 1011 | D1.1 | 001 00001 | 011101 1001 | 100010 1001 |
| D2.0 | 000 00010 | 101101 0100 | 010010 1011 | D2.1 | 001 00010 | 101101 1001 | 010010 1001 |
| D3.0 | 000 00011 | 110001 1011 | 110001 0100 | D3.1 | 001 00011 | 110001 1001 | 110001 1001 |
| D4.0 | 000 00100 | 110101 0100 | 001010 1011 | D4.1 | 001 00100 | 110101 1001 | 001010 1001 |
| D5.0 | 000 00101 | 101001 1011 | 101001 0100 | D5.1 | 001 00101 | 101001 1001 | 101001 1001 |
| D6.0 | 000 00110 | 011001 1011 | 011001 0100 | D6.1 | 001 00110 | 011001 1001 | 011001 1001 |
| D7.0 | 000 00111 | 111000 1011 | 000111 0100 | D7.1 | 001 00111 | 111000 1001 | 000111 1001 |
| D8.0 | 000 01000 | 111001 0100 | 000110 1011 | D8.1 | 001 01000 | 111001 1001 | 000110 1001 |
| D9.0 | 000 01001 | 100101 1011 | 100101 0100 | D9.1 | 001 01001 | 100101 1001 | 100101 1001 |
| D10.0 | 000 01010 | 010101 1011 | 010101 0100 | D10.1 | 001 01010 | 010101 1001 | 010101 1001 |
| D11.0 | 000 01011 | 110100 1011 | 110100 0100 | D11.1 | 001 01011 | 110100 1001 | 110100 1001 |
| D12.0 | 000 01100 | 001101 1011 | 001101 0100 | D12.1 | 001 01100 | 001101 1001 | 001101 1001 |
| D13.0 | 000 01101 | 101100 1011 | 101100 0100 | D13.1 | 001 01101 | 101100 1001 | 101100 1001 |
| D14.0 | 000 01110 | 011100 1011 | 011100 0100 | D14.1 | 001 01110 | 011100 1001 | 011100 1001 |
| D15.0 | 000 01111 | 010111 0100 | 101000 1011 | D15.1 | 001 01111 | 010111 1001 | 101000 1001 |
| D16.0 | 000 10000 | 011011 0100 | 100100 1011 | D16.1 | 001 10000 | 011011 1001 | 100100 1001 |
| D17.0 | 000 10001 | 100011 1011 | 100011 0100 | D17.1 | 001 10001 | 100011 1001 | 100011 1001 |
| D18.0 | 000 10010 | 010011 1011 | 010011 0100 | D18.1 | 001 10010 | 010011 1001 | 010011 1001 |
| D19.0 | 000 10011 | 110010 1011 | 110010 0100 | D19.1 | 001 10011 | 110010 1001 | 110010 1001 |
| D20.0 | 000 10100 | 001011 1011 | 001011 0100 | D20.1 | 001 10100 | 001011 1001 | 001011 1001 |
| D21.0 | 000 10101 | 101010 1011 | 101010 0100 | D21.1 | 001 10101 | 101010 1001 | 101010 1001 |
| D22.0 | 000 10110 | 011010 1011 | 011010 0100 | D22.1 | 001 10110 | 011010 1001 | 011010 1001 |
| D23.0 | 000 10111 | 111010 0100 | 000101 1011 | D23.1 | 001 10111 | 111010 1001 | 000101 1001 |
| D24.0 | 000 11000 | 110011 0100 | 001100 1011 | D24.1 | 001 11000 | 110011 1001 | 001100 1001 |
| D25.0 | 000 11001 | 100110 1011 | 100110 0100 | D25.1 | 001 11001 | 100110 1001 | 100110 1001 |
| D26.0 | 000 11010 | 010110 1011 | 010110 0100 | D26.1 | 001 11010 | 010110 1001 | 010110 1001 |
| D27.0 | 000 11011 | 110110 0100 | 001001 1011 | D27.1 | 001 11011 | 110110 1001 | 001001 1001 |
| D28.0 | 000 11100 | 001110 1011 | 001110 0100 | D28.1 | 001 11100 | 001110 1001 | 001110 1001 |
| D29.0 | 000 11101 | 101110 0100 | 010001 1011 | D29.1 | 001 11101 | 101110 1001 | 010001 1001 |
| D30.0 | 000 11110 | 011110 0100 | 100001 1011 | D30.1 | 001 11110 | 011110 1001 | 100001 1001 |
| D31.0 | 000 11111 | 101011 0100 | 010100 1011 | D31.1 | 001 11111 | 101011 1001 | 010100 1001 |

Table 24. Valid Data Characters (TXCTx[0] = 0, RXSTx[2:0] = 000) (continued)

| Data Byte Name | Bits | Current RD- | Current RD+ | Data Byte Name | Bits | Current RD- | Current RD+ |
|----------------|-----------|-------------|-------------|----------------|-----------|-------------|-------------|
| | HGF EDCBA | abcdei fghj | abcdei fghj | | HGF EDCBA | abcdei fghj | abcdei fghj |
| D0.2 | 010 00000 | 100111 0101 | 011000 0101 | D0.3 | 011 00000 | 100111 0011 | 011000 1100 |
| D1.2 | 010 00001 | 011101 0101 | 100010 0101 | D1.3 | 011 00001 | 011101 0011 | 100010 1100 |
| D2.2 | 010 00010 | 101101 0101 | 010010 0101 | D2.3 | 011 00010 | 101101 0011 | 010010 1100 |
| D3.2 | 010 00011 | 110001 0101 | 110001 0101 | D3.3 | 011 00011 | 110001 1100 | 110001 0011 |
| D4.2 | 010 00100 | 110101 0101 | 001010 0101 | D4.3 | 011 00100 | 110101 0011 | 001010 1100 |
| D5.2 | 010 00101 | 101001 0101 | 101001 0101 | D5.3 | 011 00101 | 101001 1100 | 101001 0011 |
| D6.2 | 010 00110 | 011001 0101 | 011001 0101 | D6.3 | 011 00110 | 011001 1100 | 011001 0011 |
| D7.2 | 010 00111 | 111000 0101 | 000111 0101 | D7.3 | 011 00111 | 111000 1100 | 000111 0011 |
| D8.2 | 010 01000 | 111001 0101 | 000110 0101 | D8.3 | 011 01000 | 111001 0011 | 000110 1100 |
| D9.2 | 010 01001 | 100101 0101 | 100101 0101 | D9.3 | 011 01001 | 100101 1100 | 100101 0011 |
| D10.2 | 010 01010 | 010101 0101 | 010101 0101 | D10.3 | 011 01010 | 010101 1100 | 010101 0011 |
| D11.2 | 010 01011 | 110100 0101 | 110100 0101 | D11.3 | 011 01011 | 110100 1100 | 110100 0011 |
| D12.2 | 010 01100 | 001101 0101 | 001101 0101 | D12.3 | 011 01100 | 001101 1100 | 001101 0011 |
| D13.2 | 010 01101 | 101100 0101 | 101100 0101 | D13.3 | 011 01101 | 101100 1100 | 101100 0011 |
| D14.2 | 010 01110 | 011100 0101 | 011100 0101 | D14.3 | 011 01110 | 011100 1100 | 011100 0011 |
| D15.2 | 010 01111 | 010111 0101 | 101000 0101 | D15.3 | 011 01111 | 010111 0011 | 101000 1100 |
| D16.2 | 010 10000 | 011011 0101 | 100100 0101 | D16.3 | 011 10000 | 011011 0011 | 100100 1100 |
| D17.2 | 010 10001 | 100011 0101 | 100011 0101 | D17.3 | 011 10001 | 100011 1100 | 100011 0011 |
| D18.2 | 010 10010 | 010011 0101 | 010011 0101 | D18.3 | 011 10010 | 010011 1100 | 010011 0011 |
| D19.2 | 010 10011 | 110010 0101 | 110010 0101 | D19.3 | 011 10011 | 110010 1100 | 110010 0011 |
| D20.2 | 010 10100 | 001011 0101 | 001011 0101 | D20.3 | 011 10100 | 001011 1100 | 001011 0011 |
| D21.2 | 010 10101 | 101010 0101 | 101010 0101 | D21.3 | 011 10101 | 101010 1100 | 101010 0011 |
| D22.2 | 010 10110 | 011010 0101 | 011010 0101 | D22.3 | 011 10110 | 011010 1100 | 011010 0011 |
| D23.2 | 010 10111 | 111010 0101 | 000101 0101 | D23.3 | 011 10111 | 111010 0011 | 000101 1100 |
| D24.2 | 010 11000 | 110011 0101 | 001100 0101 | D24.3 | 011 11000 | 110011 0011 | 001100 1100 |
| D25.2 | 010 11001 | 100110 0101 | 100110 0101 | D25.3 | 011 11001 | 100110 1100 | 100110 0011 |
| D26.2 | 010 11010 | 010110 0101 | 010110 0101 | D26.3 | 011 11010 | 010110 1100 | 010110 0011 |
| D27.2 | 010 11011 | 110110 0101 | 001001 0101 | D27.3 | 011 11011 | 110110 0011 | 001001 1100 |
| D28.2 | 010 11100 | 001110 0101 | 001110 0101 | D28.3 | 011 11100 | 001110 1100 | 001110 0011 |
| D29.2 | 010 11101 | 101110 0101 | 010001 0101 | D29.3 | 011 11101 | 101110 0011 | 010001 1100 |
| D30.2 | 010 11110 | 011110 0101 | 100001 0101 | D30.3 | 011 11110 | 011110 0011 | 100001 1100 |
| D31.2 | 010 11111 | 101011 0101 | 010100 0101 | D31.3 | 011 11111 | 101011 0011 | 010100 1100 |

Table 24. Valid Data Characters (TXCTx[0] = 0, RXSTx[2:0] = 000) (continued)

| Data Byte Name | Bits | Current RD- | Current RD+ | Data Byte Name | Bits | Current RD- | Current RD+ |
|----------------|-----------|-------------|-------------|----------------|-----------|-------------|-------------|
| | HGF EDCBA | abcdei fghj | abcdei fghj | | HGF EDCBA | abcdei fghj | abcdei fghj |
| D0.4 | 100 00000 | 100111 0010 | 011000 1101 | D0.5 | 101 00000 | 100111 1010 | 011000 1010 |
| D1.4 | 100 00001 | 011101 0010 | 100010 1101 | D1.5 | 101 00001 | 011101 1010 | 100010 1010 |
| D2.4 | 100 00010 | 101101 0010 | 010010 1101 | D2.5 | 101 00010 | 101101 1010 | 010010 1010 |
| D3.4 | 100 00011 | 110001 1101 | 110001 0010 | D3.5 | 101 00011 | 110001 1010 | 110001 1010 |
| D4.4 | 100 00100 | 110101 0010 | 001010 1101 | D4.5 | 101 00100 | 110101 1010 | 001010 1010 |
| D5.4 | 100 00101 | 101001 1101 | 101001 0010 | D5.5 | 101 00101 | 101001 1010 | 101001 1010 |
| D6.4 | 100 00110 | 011001 1101 | 011001 0010 | D6.5 | 101 00110 | 011001 1010 | 011001 1010 |
| D7.4 | 100 00111 | 111000 1101 | 000111 0010 | D7.5 | 101 00111 | 111000 1010 | 000111 1010 |
| D8.4 | 100 01000 | 111001 0010 | 000110 1101 | D8.5 | 101 01000 | 111001 1010 | 000110 1010 |
| D9.4 | 100 01001 | 100101 1101 | 100101 0010 | D9.5 | 101 01001 | 100101 1010 | 100101 1010 |
| D10.4 | 100 01010 | 010101 1101 | 010101 0010 | D10.5 | 101 01010 | 010101 1010 | 010101 1010 |
| D11.4 | 100 01011 | 110100 1101 | 110100 0010 | D11.5 | 101 01011 | 110100 1010 | 110100 1010 |
| D12.4 | 100 01100 | 001101 1101 | 001101 0010 | D12.5 | 101 01100 | 001101 1010 | 001101 1010 |
| D13.4 | 100 01101 | 101100 1101 | 101100 0010 | D13.5 | 101 01101 | 101100 1010 | 101100 1010 |
| D14.4 | 100 01110 | 011100 1101 | 011100 0010 | D14.5 | 101 01110 | 011100 1010 | 011100 1010 |
| D15.4 | 100 01111 | 010111 0010 | 101000 1101 | D15.5 | 101 01111 | 010111 1010 | 101000 1010 |
| D16.4 | 100 10000 | 011011 0010 | 100100 1101 | D16.5 | 101 10000 | 011011 1010 | 100100 1010 |
| D17.4 | 100 10001 | 100011 1101 | 100011 0010 | D17.5 | 101 10001 | 100011 1010 | 100011 1010 |
| D18.4 | 100 10010 | 010011 1101 | 010011 0010 | D18.5 | 101 10010 | 010011 1010 | 010011 1010 |
| D19.4 | 100 10011 | 110010 1101 | 110010 0010 | D19.5 | 101 10011 | 110010 1010 | 110010 1010 |
| D20.4 | 100 10100 | 001011 1101 | 001011 0010 | D20.5 | 101 10100 | 001011 1010 | 001011 1010 |
| D21.4 | 100 10101 | 101010 1101 | 101010 0010 | D21.5 | 101 10101 | 101010 1010 | 101010 1010 |
| D22.4 | 100 10110 | 011010 1101 | 011010 0010 | D22.5 | 101 10110 | 011010 1010 | 011010 1010 |
| D23.4 | 100 10111 | 111010 0010 | 000101 1101 | D23.5 | 101 10111 | 111010 1010 | 000101 1010 |
| D24.4 | 100 11000 | 110011 0010 | 001100 1101 | D24.5 | 101 11000 | 110011 1010 | 001100 1010 |
| D25.4 | 100 11001 | 100110 1101 | 100110 0010 | D25.5 | 101 11001 | 100110 1010 | 100110 1010 |
| D26.4 | 100 11010 | 010110 1101 | 010110 0010 | D26.5 | 101 11010 | 010110 1010 | 010110 1010 |
| D27.4 | 100 11011 | 110110 0010 | 001001 1101 | D27.5 | 101 11011 | 110110 1010 | 001001 1010 |
| D28.4 | 100 11100 | 001110 1101 | 001110 0010 | D28.5 | 101 11100 | 001110 1010 | 001110 1010 |
| D29.4 | 100 11101 | 101110 0010 | 010001 1101 | D29.5 | 101 11101 | 101110 1010 | 010001 1010 |
| D30.4 | 100 11110 | 011110 0010 | 100001 1101 | D30.5 | 101 11110 | 011110 1010 | 100001 1010 |
| D31.4 | 100 11111 | 101011 0010 | 010100 1101 | D31.5 | 101 11111 | 101011 1010 | 010100 1010 |

Table 24. Valid Data Characters (TXCTx[0] = 0, RXSTx[2:0] = 000) (continued)

| Data Byte Name | Bits | Current RD- | Current RD+ | Data Byte Name | Bits | Current RD- | Current RD+ |
|----------------|-----------|-------------|-------------|----------------|-----------|-------------|-------------|
| | HGF EDCBA | abcdei fghj | abcdei fghj | | HGF EDCBA | abcdei fghj | abcdei fghj |
| D0.6 | 110 00000 | 100111 0110 | 011000 0110 | D0.7 | 111 00000 | 100111 0001 | 011000 1110 |
| D1.6 | 110 00001 | 011101 0110 | 100010 0110 | D1.7 | 111 00001 | 011101 0001 | 100010 1110 |
| D2.6 | 110 00010 | 101101 0110 | 010010 0110 | D2.7 | 111 00010 | 101101 0001 | 010010 1110 |
| D3.6 | 110 00011 | 110001 0110 | 110001 0110 | D3.7 | 111 00011 | 110001 1110 | 110001 0001 |
| D4.6 | 110 00100 | 110101 0110 | 001010 0110 | D4.7 | 111 00100 | 110101 0001 | 001010 1110 |
| D5.6 | 110 00101 | 101001 0110 | 101001 0110 | D5.7 | 111 00101 | 101001 1110 | 101001 0001 |
| D6.6 | 110 00110 | 011001 0110 | 011001 0110 | D6.7 | 111 00110 | 011001 1110 | 011001 0001 |
| D7.6 | 110 00111 | 111000 0110 | 000111 0110 | D7.7 | 111 00111 | 111000 1110 | 000111 0001 |
| D8.6 | 110 01000 | 111001 0110 | 000110 0110 | D8.7 | 111 01000 | 111001 0001 | 000110 1110 |
| D9.6 | 110 01001 | 100101 0110 | 100101 0110 | D9.7 | 111 01001 | 100101 1110 | 100101 0001 |
| D10.6 | 110 01010 | 010101 0110 | 010101 0110 | D10.7 | 111 01010 | 010101 1110 | 010101 0001 |
| D11.6 | 110 01011 | 110100 0110 | 110100 0110 | D11.7 | 111 01011 | 110100 1110 | 110100 1000 |
| D12.6 | 110 01100 | 001101 0110 | 001101 0110 | D12.7 | 111 01100 | 001101 1110 | 001101 0001 |
| D13.6 | 110 01101 | 101100 0110 | 101100 0110 | D13.7 | 111 01101 | 101100 1110 | 101100 1000 |
| D14.6 | 110 01110 | 011100 0110 | 011100 0110 | D14.7 | 111 01110 | 011100 1110 | 011100 1000 |
| D15.6 | 110 01111 | 010111 0110 | 101000 0110 | D15.7 | 111 01111 | 010111 0001 | 101000 1110 |
| D16.6 | 110 10000 | 011011 0110 | 100100 0110 | D16.7 | 111 10000 | 011011 0001 | 100100 1110 |
| D17.6 | 110 10001 | 100011 0110 | 100011 0110 | D17.7 | 111 10001 | 100011 0111 | 100011 0001 |
| D18.6 | 110 10010 | 010011 0110 | 010011 0110 | D18.7 | 111 10010 | 010011 0111 | 010011 0001 |
| D19.6 | 110 10011 | 110010 0110 | 110010 0110 | D19.7 | 111 10011 | 110010 1110 | 110010 0001 |
| D20.6 | 110 10100 | 001011 0110 | 001011 0110 | D20.7 | 111 10100 | 001011 0111 | 001011 0001 |
| D21.6 | 110 10101 | 101010 0110 | 101010 0110 | D21.7 | 111 10101 | 101010 1110 | 101010 0001 |
| D22.6 | 110 10110 | 011010 0110 | 011010 0110 | D22.7 | 111 10110 | 011010 1110 | 011010 0001 |
| D23.6 | 110 10111 | 111010 0110 | 000101 0110 | D23.7 | 111 10111 | 111010 0001 | 000101 1110 |
| D24.6 | 110 11000 | 110011 0110 | 001100 0110 | D24.7 | 111 11000 | 110011 0001 | 001100 1110 |
| D25.6 | 110 11001 | 100110 0110 | 100110 0110 | D25.7 | 111 11001 | 100110 1110 | 100110 0001 |
| D26.6 | 110 11010 | 010110 0110 | 010110 0110 | D26.7 | 111 11010 | 010110 1110 | 010110 0001 |
| D27.6 | 110 11011 | 110110 0110 | 001001 0110 | D27.7 | 111 11011 | 110110 0001 | 001001 1110 |
| D28.6 | 110 11100 | 001110 0110 | 001110 0110 | D28.7 | 111 11100 | 001110 1110 | 001110 0001 |
| D29.6 | 110 11101 | 101110 0110 | 010001 0110 | D29.7 | 111 11101 | 101110 0001 | 010001 1110 |
| D30.6 | 110 11110 | 011110 0110 | 100001 0110 | D30.7 | 111 11110 | 011110 0001 | 100001 1110 |
| D31.6 | 110 11111 | 101011 0110 | 010100 0110 | D31.7 | 111 11111 | 101011 0001 | 010100 1110 |

Table 25. Valid Special Character Codes and Sequences (TXCTx = special character code or RXSTx[2:0] = 001)^[45, 46]

| S.C. Code Name | S.C. Byte Name | | | | | Current RD–
abcdei fghj | Current RD+
abcdei fghj |
|---|--------------------------------|----------------|--------------------------------|---------------------------|----------------|----------------------------|----------------------------|
| | Cypress | | | Alternate | | | |
| | S.C. Byte Name ^[47] | Bits HGF EDCBA | S.C. Byte Name ^[47] | Bits HGF EDCBA | | | |
| K28.0 | C0.0 (C00) | 000 00000 | C28.0 (C1C) | 000 11100 | 001111 0100 | 110000 1011 | |
| K28.1 ^[48] | C1.0 (C01) | 000 00001 | C28.1 (C3C) | 001 11100 | 001111 1001 | 110000 0110 | |
| K28.2 ^[48] | C2.0 (C02) | 000 00010 | C28.2 (C5C) | 010 11100 | 001111 0101 | 110000 1010 | |
| K28.3 | C3.0 (C03) | 000 00011 | C28.3 (C7C) | 011 11100 | 001111 0011 | 110000 1100 | |
| K28.4 ^[48] | C4.0 (C04) | 000 00100 | C28.4 (C9C) | 100 11100 | 001111 0010 | 110000 1101 | |
| K28.5 ^[48, 49] | C5.0 (C05) | 000 00101 | C28.5 (CBC) | 101 11100 | 001111 1010 | 110000 0101 | |
| K28.6 ^[48] | C6.0 (C06) | 000 00110 | C28.6 (CDC) | 110 11100 | 001111 0110 | 110000 1001 | |
| K28.7 ^[48, 50] | C7.0 (C07) | 000 00111 | C28.7 (CFC) | 111 11100 | 001111 1000 | 110000 0111 | |
| K23.7 | C8.0 (C08) | 000 01000 | C23.7 (CF7) | 111 10111 | 111010 1000 | 000101 0111 | |
| K27.7 | C9.0 (C09) | 000 01001 | C27.7 (CFB) | 111 11011 | 110110 1000 | 001001 0111 | |
| K29.7 | C10.0 (C0A) | 000 01010 | C29.7 (CFD) | 111 11101 | 101110 1000 | 010001 0111 | |
| K30.7 | C11.0 (C0B) | 000 01011 | C30.7 (CFE) | 111 11110 | 011110 1000 | 100001 0111 | |
| End of Frame Sequence | | | | | | | |
| EOFxx ^[51] | C2.1 (C22) | 001 00010 | C2.1 (C22) | 001 00010 | –K28.5,Dn.xxx0 | +K28.5,Dn.xxx1 | |
| Code Rule Violation and SVS Tx Pattern | | | | | | | |
| Exception ^[50, 52] | C0.7 (CE0) | 111 00000 | C0.7 (CE0) | 111 00000 ^[56] | 100111 1000 | 011000 0111 | |
| –K28.5 ^[53] | C1.7 (CE1) | 111 00001 | C1.7 (CE1) | 111 00001 ^[56] | 001111 1010 | 001111 1010 | |
| +K28.5 ^[54] | C2.7 (CE2) | 111 00010 | C2.7 (CE2) | 111 00010 ^[56] | 110000 0101 | 110000 0101 | |
| Running Disparity Violation Pattern | | | | | | | |
| Exception ^[55] | C4.7 (CE4) | 111 00100 | C4.7 (CE4) | 111 00100 ^[56] | 110111 0101 | 001000 1010 | |

Notes

- 45. All codes not shown are reserved.
- 46. Notation for Special Character Code Name is consistent with Fibre Channel and ESCON naming conventions. Special Character Code Name is intended to describe binary information present on I/O pins. Common usage for the name can either be in the form used for describing Data patterns (that is, C0.0 through C31.7), or in hex notation (that is, Cnn where nn = the specified value between 00 and FF).
- 47. Both the Cypress and alternate encodings may be used for data transmission to generate specific Special Character Codes. The decoding process for received characters generates Cypress codes or Alternate codes as selected by the DECMODE configuration input.
- 48. These characters are used for control of ESCON interfaces. They can be sent as embedded commands or other markers when not operating using ESCON protocols.
- 49. The K28.5 character is used for framing operations by the receiver. It is also the pad or fill character transmitted to maintain the serial link when no user data is available.
- 50. Care must be taken when using this Special Character code. When a K28.7(C7.0) or SVS(C0.7) is followed by a D11.x or D20.x, an alias K28.5 sync character is created. These sequences can cause erroneous framing and should be avoided while RFEN = HIGH.
- 51. C2.1 = Transmit either –K28.5+ or +K28.5– as determined by Current RD and modify the Transmission Character that follows, by setting its least significant bit to 1 or 0. If Current RD at the start of the following character is plus (+) the LSB is set to 0, and if Current RD is minus (–) the LSB becomes 1. This modification allows construction of X3.230 “EOF” frame delimiters wherein the second data byte is determined by the Current RD. For example, to send “EOFd” the controller could issue the sequence C2.1–D21.4– D21.4–D21.4, and the HOTLink Transmitter sends either K28.5–D21.4–D21.4–D21.4 or K28.5–D21.5– D21.4–D21.4 based on Current RD. Likewise to send “EOFdti” the controller could issue the sequence C2.1–D10.4–D21.4–D21.4, and the HOTLink Transmitter sends either K28.5–D10.4–D21.4– D21.4 or K28.5–D10.5–D21.4– D21.4 based on Current RD. The receiver, never outputs this Special Character, since K28.5 is decoded as C5.0, C1.7, or C2.7, and the subsequent bytes are decoded as data.
- 52. C0.7 = Transmit a deliberate code rule violation. The code chosen for this function follows the normal Running Disparity rules. The receiver outputs this Special Character, only if the Transmission Character being decoded is not found in the tables.
- 53. C1.7 = Transmit Negative K28.5 (–K28.5+) disregarding Current RD. The receiver outputs this Special Character, only if K28.5 is received with the wrong running disparity. The receiver outputs C1.7, if –K28.5 is received with RD+, otherwise K28.5 is decoded as C5.0 or C2.7.
- 54. C2.7 = Transmit Positive K28.5 (+K28.5–) disregarding Current RD. The receiver outputs this Special Character, only if K28.5 is received with the wrong running disparity. The receiver outputs C2.7, if +K28.5 is received with RD–, otherwise K28.5 is decoded as C5.0 or C1.7.
- 55. C4.7 = Transmit a deliberate code rule violation to indicate a Running Disparity violation. The receiver outputs this Special Character, only if the Transmission Character being decoded is found in the tables, but Running Disparity does not match. This might indicate that an error occurred in a prior byte.
- 56. Supported only for data transmission. The receive status for these conditions are reported by specific combinations of receive status bits.

Ordering Information

| Speed | Ordering Code | Package Name | Package Type | Operating Range |
|----------|--------------------|--------------|-----------------------------|-----------------|
| Standard | CYP15G0201DXB-BBXC | BB196A | Pb-Free 196-Ball Grid Array | Commercial |
| Standard | CYP15G0201DXB-BBXI | BB196A | Pb-Free 196-Ball Grid Array | Industrial |

Ordering Code Definitions

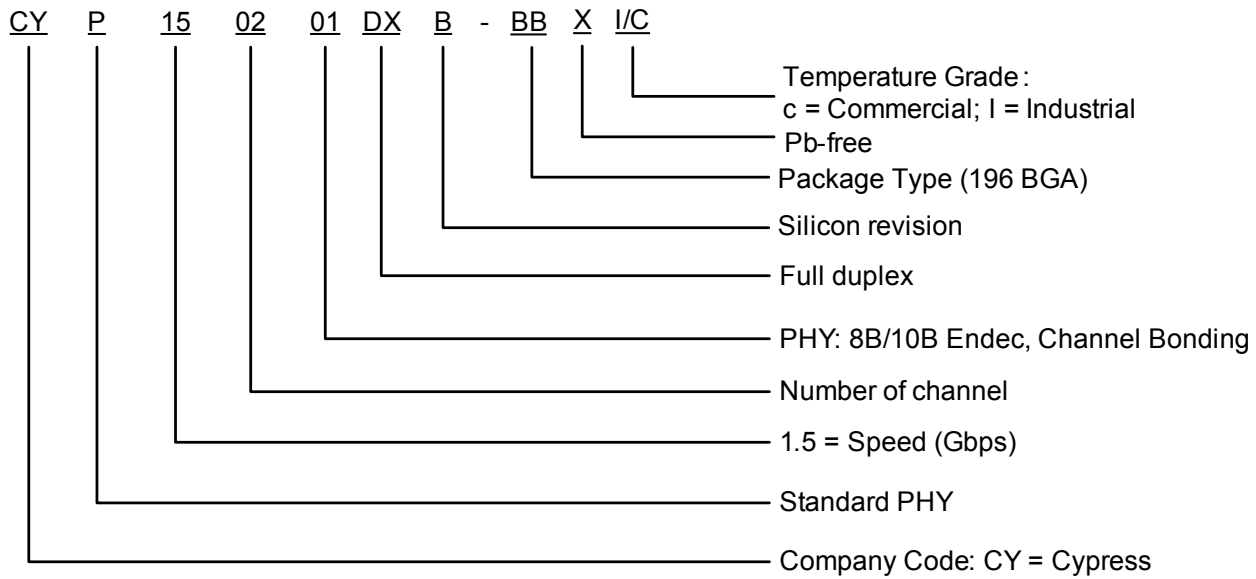

Package Diagram

Figure 5. 196-ball FBGA (15 × 15 × 1.5 mm) BB196A Package Outline, 51-85156

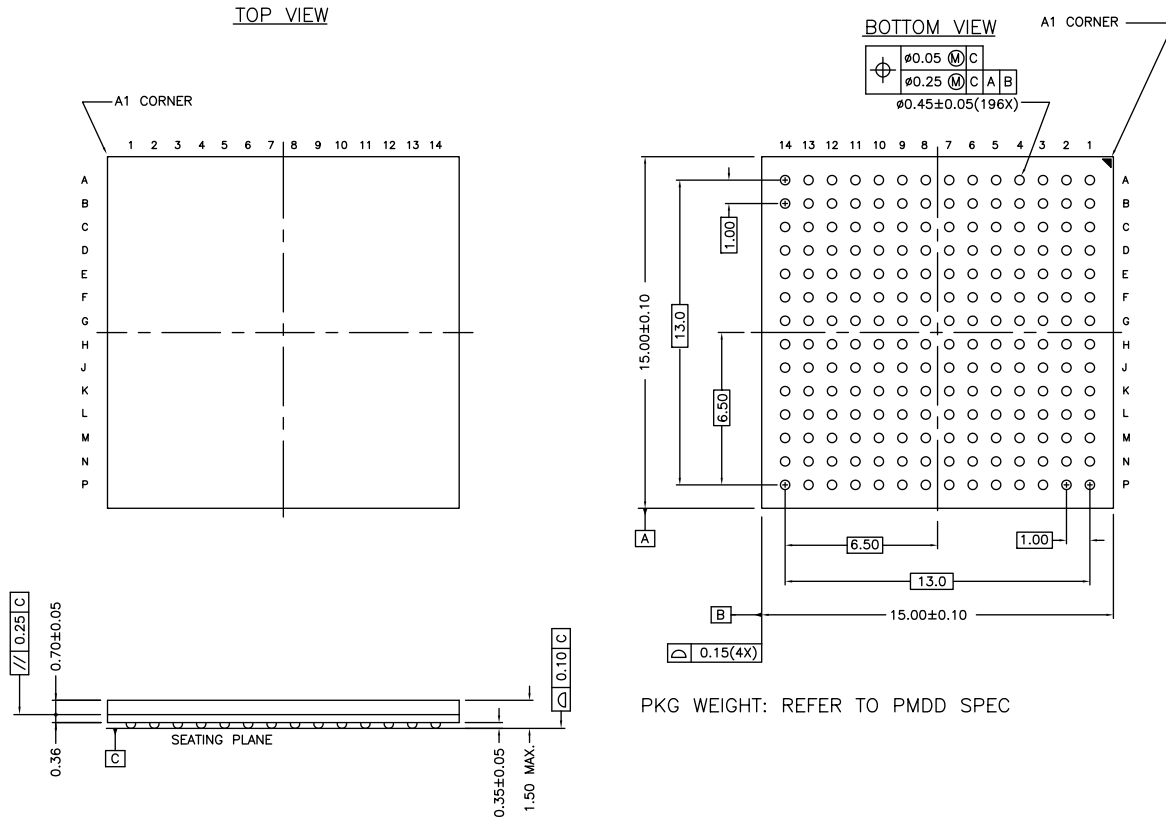

51-85156 *D

Acronyms

Table 26. Acronyms Used in this Document

| Acronym | Description |
|---------|--------------------------------|
| AC | alternating current |
| BIST | built-in self-test |
| CDR | clock/data recovery |
| CML | current mode logic |
| DC | direct current |
| ECL | emitter coupled logic |
| I/O | input/output |
| JTAG | joint test action group |
| LFI | link fault indicator |
| LFSR | linear feedback shift register |
| LFSR | linear feedback shift register |
| LPEN | local loopback input |
| PECL | positive-ECL or pseudo-ECL |
| PLL | phase-locked loop |
| TTL | transistor transistor logic |
| VCO | voltage controlled oscillator |

Document Conventions

Units of Measure

Table 27. Units of Measure

| Symbol | Unit of Measure |
|--------|-----------------|
| °C | degree Celsius |
| Hz | hertz |
| KB | 1024 bytes |
| Kbit | 1024 bits |
| kHz | kilohertz |
| kΩ | kilohm |
| MHz | megahertz |
| MΩ | megaohm |
| μA | microampere |
| μs | microsecond |
| μV | microvolt |
| μW | microwatt |
| mA | milliampere |
| ms | millisecond |
| mV | millivolt |
| nA | nanoampere |
| ns | nanosecond |
| nV | nanovolt |
| Ω | ohm |
| ps | picosecond |

Document History Page

| Document Title: CYP15G0201DXB, Dual-channel HOTLink II™ Transceiver
Document Number: 38-02058 | | | | |
|--|---------|------------------|-----------------|---|
| Revision | ECN | Origin of Change | Submission Date | Description of Change |
| ** | 116633 | SDR | 07/16/02 | New data sheet |
| *A | 119705 | LMN | 10/30/02 | Revised receive block diagram for RXCLKC+ signal
Changed TXPERx description
Changed TXCLKO description
Corrected RXCLKB- description in REFCLK clocking mode to be disabled
Removed reference to ATM support
Removed the LOW setting for FRAMCHAR and related references
Changed the I _{OST} boundary values
Changed V _{ODIF} and V _{OLC} for CML output
Changed the t _{TXCLKR} and t _{TXCLKF} min. values
Changed t _{TXDS} and t _{TXDH} and t _{TREFFDS} and t _{TREFFDH}
Changed t _{REFADV-} , t _{REFCDV-} , and t _{REFCDV+}
Changed the JTAG ID from 0C80C069 to 1C80C069
Added a section for characterization and Standards compliance
Changed I/O type of RXCLKC in I/O coordinates table |
| *B | 122212 | RBI | 12/28/02 | Document Control minor change |
| *C | 122547 | CGX | 12/9/02 | Changed Minimum t _{RISE} /t _{FALL} for CML
Changed t _{RXLOCK}
Changed t _{DJ} , t _{RJ}
Changed t _{JTOL}
Changed t _{TXLOCK}
Changed t _{RXCLKH} , t _{RXCLKL}
Changed t _{TXCLKOD+} , t _{TXCLKOD-}
Changed Power specs
Changed verbiage...Paragraph: Clock/Data Recovery
Changed verbiage...Paragraph: Range Control
Added Power-up Requirements |
| *D | 124548 | LJN | 02/13/03 | Minor Change: Corrected errors and Power-up notes |
| *E | 124995 | POT | 04/15/03 | Changed CYP15G0201DXB to CYP(V)15G0201DXB type corresponding to the Video-compliant parts
Reduced the lower limit of the serial signaling rate from 200 Mbaud to 195 Mbaud and changed the associated specifications accordingly |
| *F | 128368 | PDS | 07/28/03 | Revised the value of t _{RREFDV} , t _{REFADV+} and t _{REFCDV+} |
| *G | 131900 | PDS | 01/30/04 | When TXCKSEL = MID or HIGH, TXRATE = HIGH is an invalid mode. Made appropriate changes to reflect this invalid condition.
Removed requirement of AC coupling for Serial I/Os for interfacing with LVPECL I/Os.
Changed LFIx to Asynchronous output.
Expanded the CDR Range Controller's permissible frequency offset between incoming serial signalling rate and Reference clock from ±200-PPM to ±1500-PPM (changed parameter t _{REFRX}).
Added Table for RXSTx[2:0] status for non-bonded (Independent Channel) mode of operation for clarity. Separated the Receive BIST status to a new Table for clarity. |
| *H | 338721 | SUA | See ECN | Added CYW15G0201DXB part number for OBSAI RP3 compliance to support operating data rate up to 1540 Mbaud. Made changes to reflect OBSAI RP3 and CPR compliance. Added Pb-Free Package option for all parts listed in the datasheet
Changed MBd to Mbaud in SPDSEL pin description |
| *I | 2897032 | CGX | 03/23/10 | Removed inactive parts from Ordering Information.
Updated Package Diagram . |

Document History Page (continued)

| Document Title: CYP15G0201DXB, Dual-channel HOTLink II™ Transceiver
Document Number: 38-02058 | | | | |
|--|---------|------------------|-----------------|--|
| Revision | ECN | Origin of Change | Submission Date | Description of Change |
| *J | 2905908 | CGX | 04/06/10 | Removed CYV and CYW from the title.
Removed CYP15G0201DXB-BBXI, CYV15G0201DXB-BBXC and CYV15G0201DXB-BBXI parts from ordering information.
Updated Package Diagram . |
| *K | 2955995 | CGX | 07/30/10 | Removed references to CYV15G0201DXB and CYW15G0201DXB.
Added Acronyms .
Updated to new template. |
| *L | 3539174 | SAAC | 03/01/2012 | Updated Ordering Information and added Ordering Code Definitions.
Updated Package Diagram .
Added Units of Measure . |
| *M | 4685875 | YLIU | 03/16/2015 | Updated Package Diagram :
spec 51-85156 – Changed revision from *C to *D.
Updated to new template.
Completing Sunset Review. |
| *N | 5564447 | YLIU/ELG | 12/23/2016 | Changed “8-/10-B” references to “8B/10B”.
Corrected typos.
Updated the template. |
| *O | 5962450 | AESATMP8 | 11/09/2017 | Updated logo and Copyright. |

Sales, Solutions, and Legal Information

Worldwide Sales and Design Support

Cypress maintains a worldwide network of offices, solution centers, manufacturer's representatives, and distributors. To find the office closest to you, visit us at [Cypress Locations](#).

Products

| | |
|---|--|
| ARM [®] Cortex [®] Microcontrollers | cypress.com/arm |
| Automotive | cypress.com/automotive |
| Clocks & Buffers | cypress.com/clocks |
| Interface | cypress.com/interface |
| Internet of Things | cypress.com/iot |
| Memory | cypress.com/memory |
| Microcontrollers | cypress.com/mcu |
| PSoC | cypress.com/psoc |
| Power Management ICs | cypress.com/pmhc |
| Touch Sensing | cypress.com/touch |
| USB Controllers | cypress.com/usb |
| Wireless Connectivity | cypress.com/wireless |

PSoC[®] Solutions

[PSoC 1](#) | [PSoC 3](#) | [PSoC 4](#) | [PSoC 5LP](#) | [PSoC 6](#)

Cypress Developer Community

[Forums](#) | [WICED IOT Forums](#) | [Projects](#) | [Video](#) | [Blogs](#) | [Training](#) | [Components](#)

Technical Support

cypress.com/support

© Cypress Semiconductor Corporation, 2002-2017. This document is the property of Cypress Semiconductor Corporation and its subsidiaries, including Spansion LLC ("Cypress"). This document, including any software or firmware included or referenced in this document ("Software"), is owned by Cypress under the intellectual property laws and treaties of the United States and other countries worldwide. Cypress reserves all rights under such laws and treaties and does not, except as specifically stated in this paragraph, grant any license under its patents, copyrights, trademarks, or other intellectual property rights. If the Software is not accompanied by a license agreement and you do not otherwise have a written agreement with Cypress governing the use of the Software, then Cypress hereby grants you a personal, non-exclusive, nontransferable license (without the right to sublicense) (1) under its copyright rights in the Software (a) for Software provided in source code form, to modify and reproduce the Software solely for use with Cypress hardware products, only internally within your organization, and (b) to distribute the Software in binary code form externally to end users (either directly or indirectly through resellers and distributors), solely for use on Cypress hardware product units, and (2) under those claims of Cypress's patents that are infringed by the Software (as provided by Cypress, unmodified) to make, use, distribute, and import the Software solely for use with Cypress hardware products. Any other use, reproduction, modification, translation, or compilation of the Software is prohibited.

TO THE EXTENT PERMITTED BY APPLICABLE LAW, CYPRESS MAKES NO WARRANTY OF ANY KIND, EXPRESS OR IMPLIED, WITH REGARD TO THIS DOCUMENT OR ANY SOFTWARE OR ACCOMPANYING HARDWARE, INCLUDING, BUT NOT LIMITED TO, THE IMPLIED WARRANTIES OF MERCHANTABILITY AND FITNESS FOR A PARTICULAR PURPOSE. To the extent permitted by applicable law, Cypress reserves the right to make changes to this document without further notice. Cypress does not assume any liability arising out of the application or use of any product or circuit described in this document. Any information provided in this document, including any sample design information or programming code, is provided only for reference purposes. It is the responsibility of the user of this document to properly design, program, and test the functionality and safety of any application made of this information and any resulting product. Cypress products are not designed, intended, or authorized for use as critical components in systems designed or intended for the operation of weapons, weapons systems, nuclear installations, life-support devices or systems, other medical devices or systems (including resuscitation equipment and surgical implants), pollution control or hazardous substances management, or other uses where the failure of the device or system could cause personal injury, death, or property damage ("Unintended Uses"). A critical component is any component of a device or system whose failure to perform can be reasonably expected to cause the failure of the device or system, or to affect its safety or effectiveness. Cypress is not liable, in whole or in part, and you shall and hereby do release Cypress from any claim, damage, or other liability arising from or related to all Unintended Uses of Cypress products. You shall indemnify and hold Cypress harmless from and against all claims, costs, damages, and other liabilities, including claims for personal injury or death, arising from or related to any Unintended Uses of Cypress products.

Cypress, the Cypress logo, Spansion, the Spansion logo, and combinations thereof, WICED, PSoC, CapSense, EZ-USB, F-RAM, and Traveo are trademarks or registered trademarks of Cypress in the United States and other countries. For a more complete list of Cypress trademarks, visit cypress.com. Other names and brands may be claimed as property of their respective owners.



Стандарт Электрон Связь

Мы молодая и активно развивающаяся компания в области поставок электронных компонентов. Мы поставляем электронные компоненты отечественного и импортного производства напрямую от производителей и с крупнейших складов мира.

Благодаря сотрудничеству с мировыми поставщиками мы осуществляем комплексные и плановые поставки широчайшего спектра электронных компонентов.

Собственная эффективная логистика и склад в обеспечивает надежную поставку продукции в точно указанные сроки по всей России.

Мы осуществляем техническую поддержку нашим клиентам и предпродажную проверку качества продукции. На все поставляемые продукты мы предоставляем гарантию .

Осуществляем поставки продукции под контролем ВП МО РФ на предприятия военно-промышленного комплекса России , а также работаем в рамках 275 ФЗ с открытием отдельных счетов в уполномоченном банке. Система менеджмента качества компании соответствует требованиям ГОСТ ISO 9001.

Минимальные сроки поставки, гибкие цены, неограниченный ассортимент и индивидуальный подход к клиентам являются основой для выстраивания долгосрочного и эффективного сотрудничества с предприятиями радиоэлектронной промышленности, предприятиями ВПК и научно-исследовательскими институтами России.

С нами вы становитесь еще успешнее!

Наши контакты:

Телефон: +7 812 627 14 35

Электронная почта: sales@st-electron.ru

Адрес: 198099, Санкт-Петербург,
Промышленная ул, дом № 19, литера Н,
помещение 100-Н Офис 331