

EasyPIC PRO^{v7}

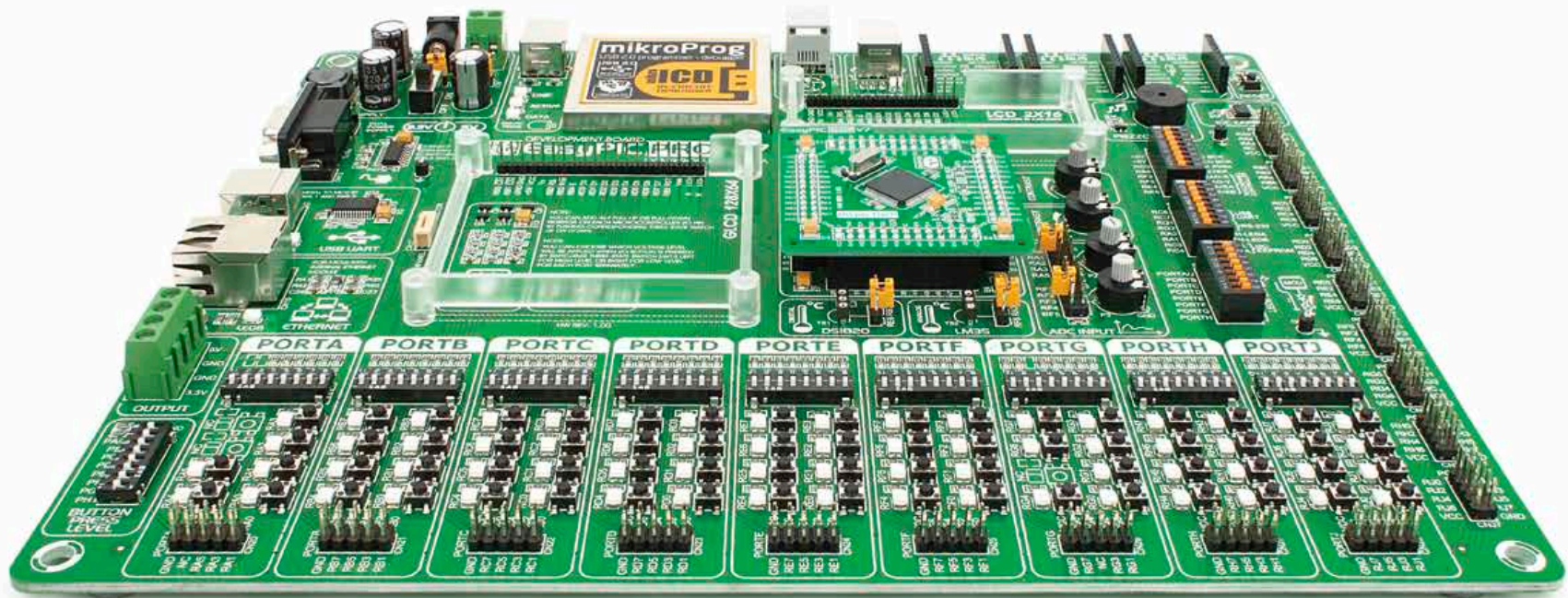

100

microcontrollers supported
The ultimate PIC® board



Supports 3.3V and 5V devices
Dual Power Supply



Easily add extra boards
mikroBUS™ sockets



Four connectors for each port
Amazing Connectivity



Fast USB 2.0 programmer and
In-Circuit Debugger

To our valued customers

From the day one, we in MikroElektronika gave ourselves the highest possible goals in pursuit of excellence. That same day, the idea of EasyPIC™ development board was born. And we all grew together with EasyPIC™. In its each and tiniest piece we had put all of our energy, creativity and sense of what's best for an engineer. I've personally assembled hundreds of early EasyPIC™ boards myself with my home soldering iron.

EasyPIC PRO™ follows the same path. With the new 7th generation of high pin count PIC® boards it emerged as a unified and clear concept, supporting both 5V and 3.3V microcontrollers. Now we proudly say that it's one of a kind in the world - good looking, powerful and easy to use.

You made the right choice. But the fun has only just begun!



Nebojsa Matic,
Owner and General Manager
of MikroElektronika

Table of contents

Introduction

Introduction	04
It's good to know	05

Power Supply

Dual power supply	06
-------------------------	----

Default MCU card

Supported microcontrollers	08
----------------------------------	----

Programmer/debugger

On-board programmer	12
Installing programmer drivers	14
Programming software	15
mikroCD™ - In Circuit Debugger	16

Connectivity

Input/Output Group	18
mikroBUS™ sockets	20
Click Boards™ are plug and play	21

Communication

UART via RS-232	22
UART via USB	23
USB device communication	24
Ethernet communication	25

Displays

LCD 2x16 characters	26
GLCD 128x64px	27
Touchpanel controller	28

Other modules

Piezo Buzzer	29
DS1820 - Digital Temperature Sensor	30
LM35 - Analog Temperature Sensor	31
ADC inputs	32
I ² C EEPROM	33
Output voltages	34
Additional GNDs	35
What's Next?	36

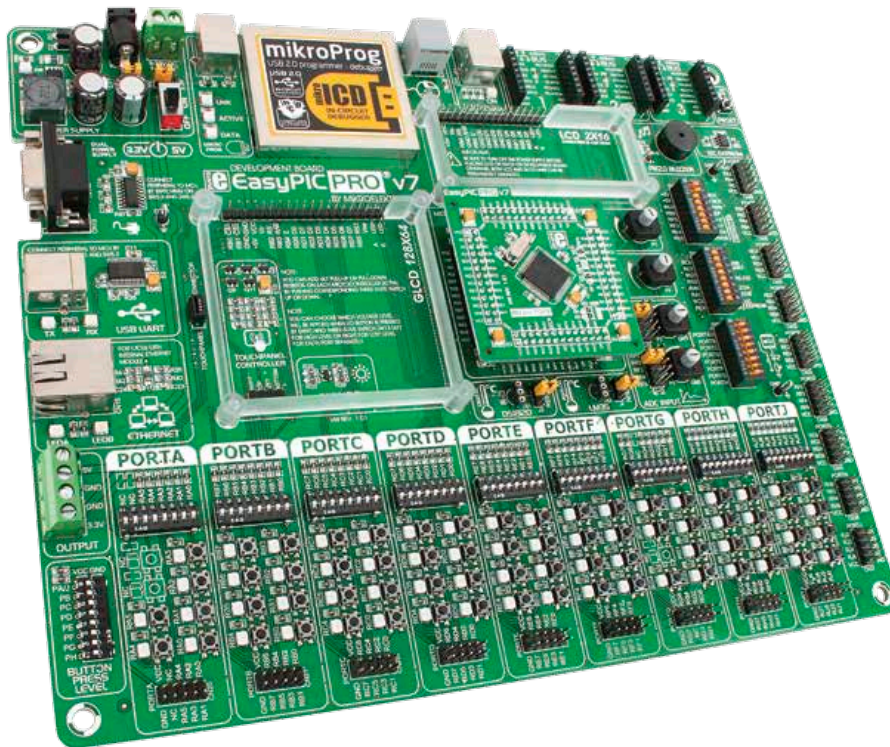

Introduction

For the first time in history we have managed to combine all the features of BIGPIC6 and LV18F v6 boards, which supported high pin count PICs into the unique EasyPIC™ PRO v7. Supporting microcontrollers in both 5V and 3.3V power supply technology, this board is truly fantastic tool for development. We have put a lot of effort into board design, making it easy to use, and we have placed lots of modules that will help you in your work. Newly redesigned MCU sockets are here to stay. They are well organized and cover all high-pin-count PIC® microcontrollers in TQFP packaging. We carefully picked high-quality components and chose a 2.4mm PCB, which makes this board especially durable. We hope you will enjoy it as much as we do.

EasyPIC PRO™ v7 Development Team

Two Connectors for each port Amazing connectivity

EasyPIC PRO™ v7 is all about connectivity. Having two different connectors for each port, you can connect accessory boards, sensors and your custom electronics easier than ever before.



Everything is already here mikroProg™ on board

Powerful on-board mikroProg™ programmer and In-Circuit debugger can program and debug nearly 100 microcontrollers. You will need it, whether you are a professional or a beginner.

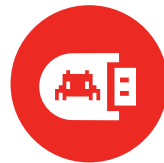

3.3V and 5V power supply Multimedia peripherals

EasyPIC PRO™ v7 is among few development boards which support both 3.3V and 5V microcontrollers. This feature greatly increases the number of supported MCUs. It's like having two boards instead of one!

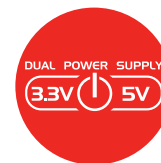

For easier connections mikroBUS™ support

Just plug in your mikroBUS™ board, and it's ready to work. We picked up a set of the most useful pins you need for development and made a pinout standard you will enjoy using.



It's good to know

PIC18F87K22 is the default microcontroller!

PIC18F87K22 is the default chip of EasyPIC PRO™ v7. Featuring nanoWatt XLP™ technology, it has **16 MIPS** operation, **128K bytes** of linear program memory, **3896 bytes** of linear data memory, and support for a wide range of power supply from **1.8V to 5V**. It's loaded with great modules: 69 General purpose **I/O pins**, 24 Analog Input pins (**AD**), internal Real time clock and calendar (**RTCC**), support for Capacitive Touch Sensing using Charge Time Measurement Unit (**CTMU**), six **8-bit timers** and five **16-bit timers**. It also has ten **CCP** modules, three **Comparators** and two **MSSP** modules which can be either **SPI** or **I²C**.

- Great choice for both beginners and professionals
- Rich with modules
- Comes with examples for mikroC, mikroBasic and mikroPascal compilers



System Specification



power supply
7-23V AC or 9-32V DC
or via USB cable (5V DC)



power consumption
~90mA at 5V when all peripheral
modules are disconnected



board dimensions
266 x 220mm (10.47 x 8.66 inch)



weight
475g (1.0472 lbs)

Package contains



1 Damage resistant protective box



2 EasyPIC PRO™ v7 board in antistatic bag



3 USB cable



4 User Manuals and Board schematics

Power supply

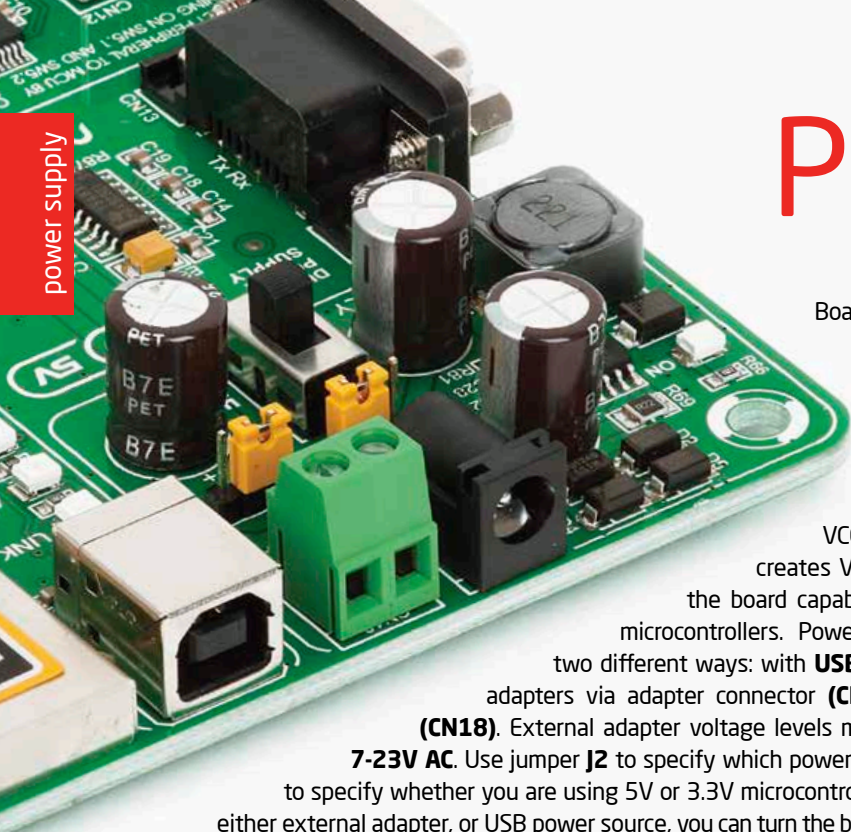

Board contains switching power supply that creates stable voltage and current levels necessary for powering each part of the board. Power supply section contains two power regulators: **MC34063A**, which generates VCC-5V, and **MC33269DT3.3** which creates VCC-3.3V power supply, thus making the board capable of supporting both 5V and 3.3V microcontrollers. Power supply unit can be powered in two different ways: with **USB power supply**, and using external adapters via adapter connector (**CN19**) or additional screw terminals (**CN18**). External adapter voltage levels must be in range of **9-32V DC and 7-23V AC**. Use jumper **J2** to specify which power source you are using, and jumper **J1** to specify whether you are using 5V or 3.3V microcontroller. Upon providing the power using either external adapter, or USB power source, you can turn the board on using **SWITCH 1 (Figure 3-1)**.

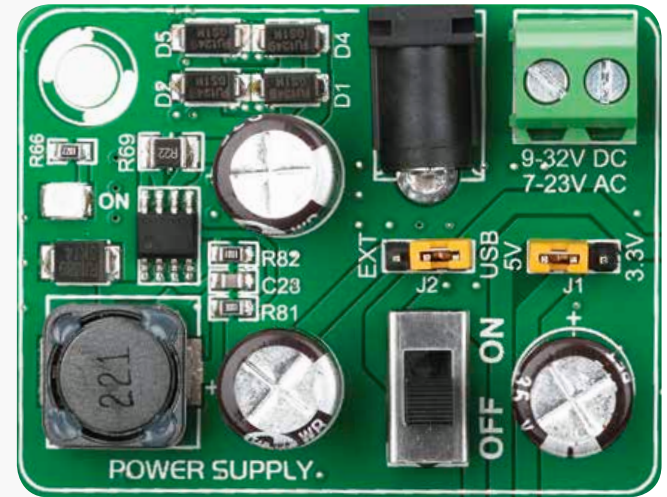

Figure 3-1: Dual power supply unit of EasyPIC PRO™ v7

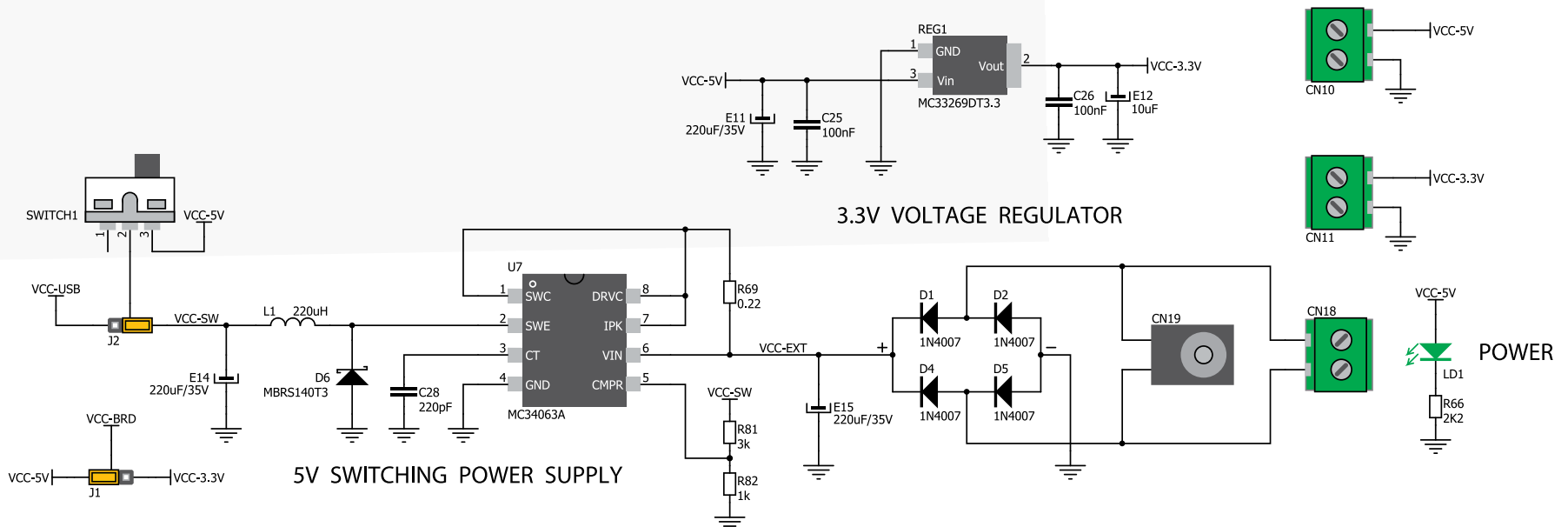

Figure 3-2: Dual power supply unit schematics

DUAL POWER SUPPLY



Smart engineering of EasyPIC PRO™ v7 development board allowed us to support both 3.3V and 5V microcontrollers on a single board, which is almost 100 high pin count PIC® devices.

Power supply:

via DC connector or screw terminals (7V to 23V AC or 9V to 32V DC), or via USB cable (5V DC)

Power consumption:

up to 600mA (depending on how many on-board modules are currently active)

How to power the board?

1. With USB cable



Set J2 jumper to USB position

To power the board with USB cable, place jumper **J2** in USB position, and place jumper **J1** in 5V or 3.3V position, depending on which microcontroller you are using. You can then plug in the USB cable as shown on images **1** and **2**, and turn the power switch ON.

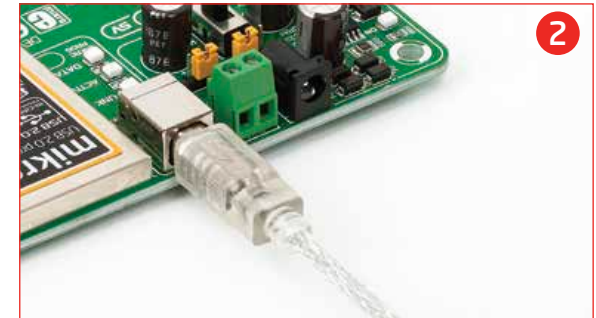

2. Using adapter



Set J2 jumper to EXT position

To power the board via adapter connector, place jumper **J2** in EXT position, and place jumper **J1** in 5V or 3.3V position, depending on which microcontroller you are using. You can then plug in the adapter cable as shown on images **3** and **4**, and turn the power switch ON.

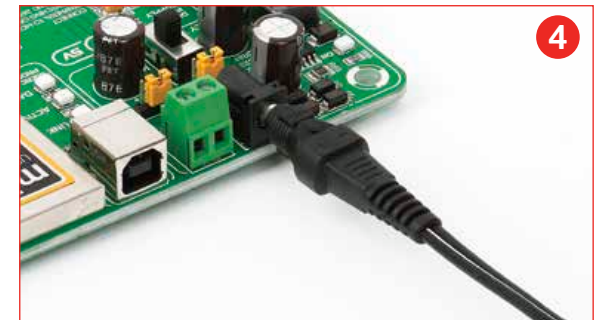

3. With laboratory power supply



Set J2 jumper to EXT position

To power the board using screw terminals, place jumper **J2** in EXT position, and place jumper **J1** in 5V or 3.3V position, depending on which microcontroller you are using. You can then plug in the adapter cable as shown on images **5** and **6**, and turn the power switch ON.

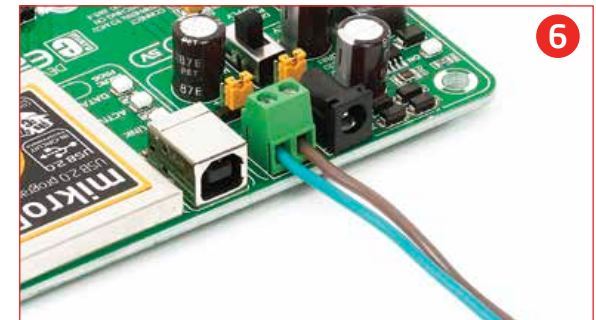
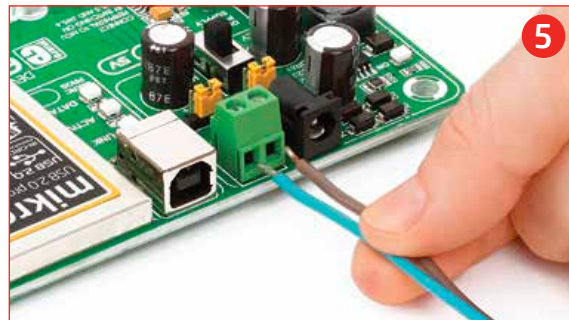

Default MCU card

Microcontrollers are supported using specialized MCU cards containing 104 pins, which are placed into the on-board female MCU socket. Currently, there are three types of cards: **Standard 80-pin TQFP**, **Ethernet 80-pin TQFP card** and **Ethernet 100-pin TQFP PF card**. Standard card supports 80-pin PIC18Fxxxx, PIC18Fxxjxx and PIC18FxxKxx microcontrollers, with or without USB support. It contains several SMD jumpers, which are supposed to be placed or removed, depending on the microcontroller.

Default MCU card that comes with the EasyPIC PRO™ v7 package is shown on **Figure 4-1**. It contains **PIC18F87K22** microcontroller which is loaded with on-chip modules and is a great choice for both beginners and professionals. After testing and building the final program, this card can also be taken out of the board socket and used in your final device.

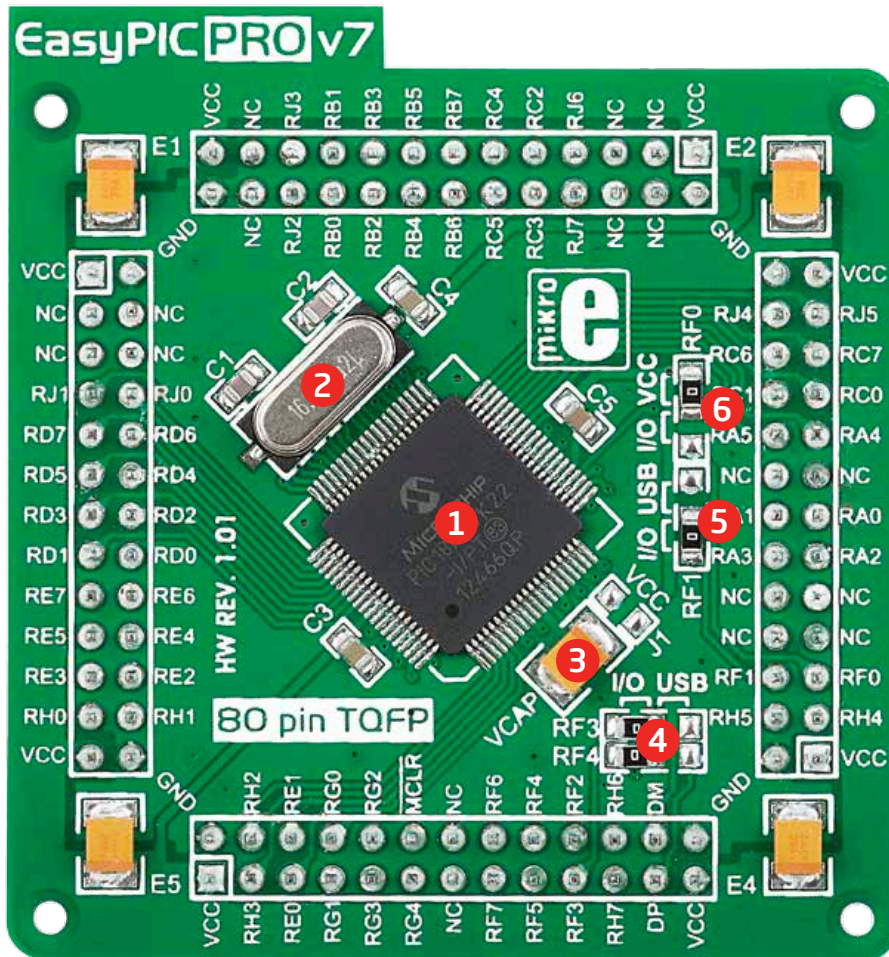

Figure 4-1: Default MCU card with PIC18F87K22

- 1 **PIC18F87K22 microcontroller.** Featuring nanoWatt XLP™ technology, it has 16 MIPS operation, 128K bytes of linear program memory, 3896 bytes of linear data memory, and support for a wide range of power supply from 1.8V to 5V.
- 2 **16MHz crystal oscillator.** We carefully chose the most convenient crystal value that provides clock frequency which can be used directly, or with the PLL multipliers and dividers to create higher MCU clock value.
- 3 **VCAP jumper.** Some PIC18FK and all PIC18FJ microcontrollers have cores that work on 1.8V-2.5V voltage range, and peripherals that work with 3.3V and 5V voltages. Internally, those microcontrollers have power regulators which adjust the core voltage levels. In order for those devices to have a stable operation of the core, manufacturer recommends that decoupling capacitive filters should be provided, and connected between specific microcontroller pins designated with VCAP and GND. This MCU card provides a VCAP jumper which is used for this purpose. **Jumper is removed by default.**
- 4 **USB communication lines.** These two jumpers, when in USB position, connect **D+** and **D-** lines of the on-board USB connector with **RF3** and **RF4** microcontroller pins. Since PIC18F87K22 doesn't support USB, **jumpers are in I/O position.**
- 5 **Vusb line jumper.** For PIC18F8xJ5x devices, this jumper should be connected to VCC for enabling internal USB controller. Since PIC18F87K22 doesn't support USB, **this jumper is in I/O position.**
- 6 **ENVREG selection jumper.** PIC18FJ and PIC18FK microcontrollers are using internal voltage regulator which is enabled by placing this jumper in **VCC position.**

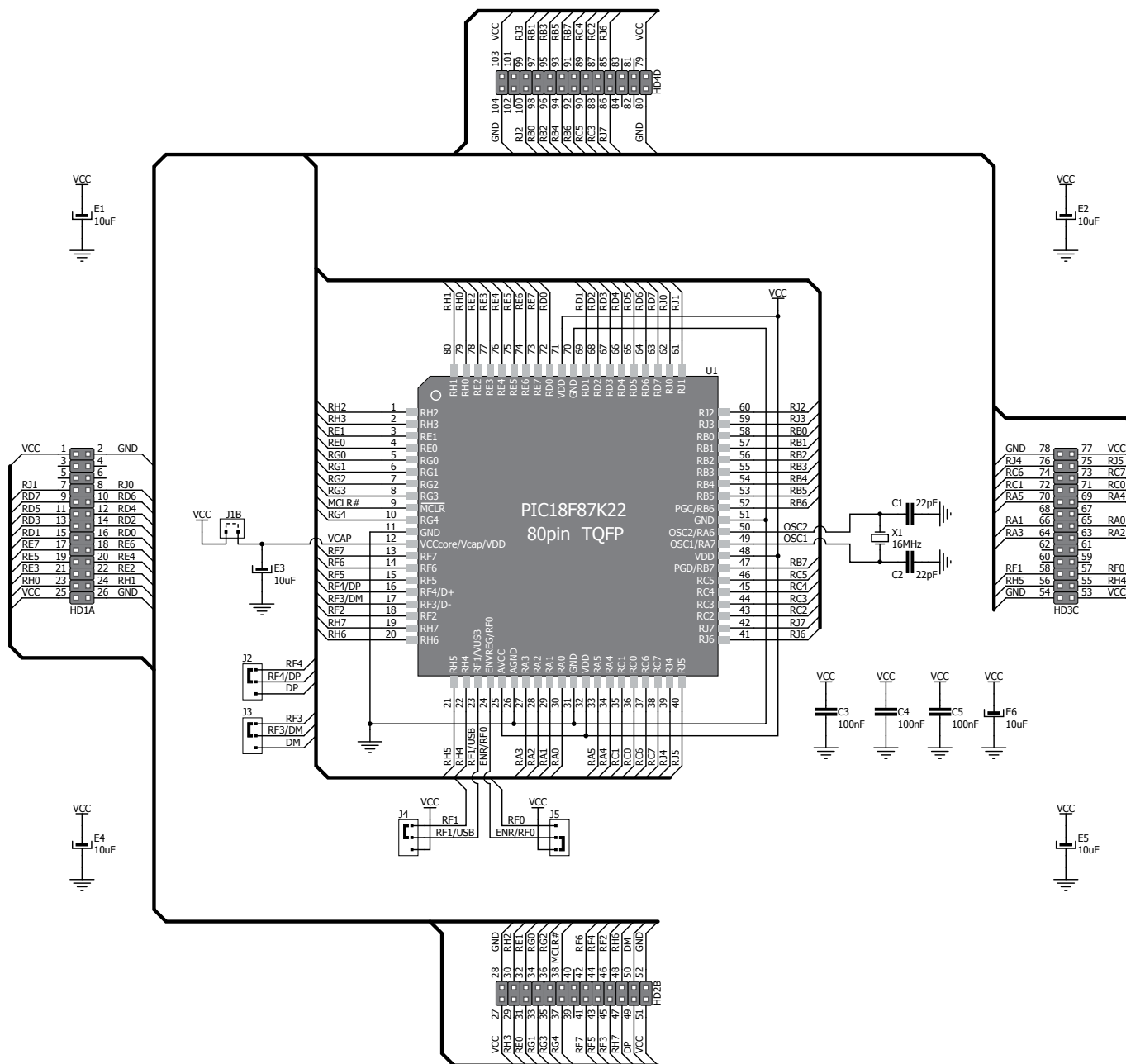

Figure 4-2: Default MCU card schematics

How to properly place your MCU card into the socket?

Before you plug the microcontroller card into the socket, make sure that the **power supply is turned off**. Images below show how to correctly plug the card. First make sure that MCU card orientation matches the silkscreen outline on the

EasyPIC PRO™ v7 board MCU socket. Place the MCU card over the socket, so each male header encloses the right angle with the female socket, as shown in **Figure 4-2**. Then put the MCU card slowly down until all the pins match the socket. Check again if

everything is placed correctly and press the MCU card until it is completely plugged into the socket as shown in **Figure 4-3**. If done correctly, all pins should be fully inserted. Only now you can turn on the power supply.

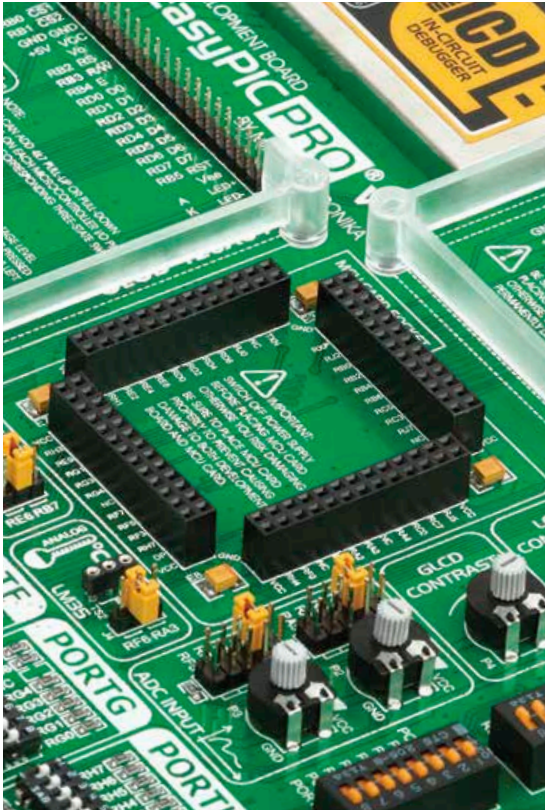

1 Figure 4-2: On-board MCU socket has silkscreen markings which will help you to correctly orient the MCU card before inserting.

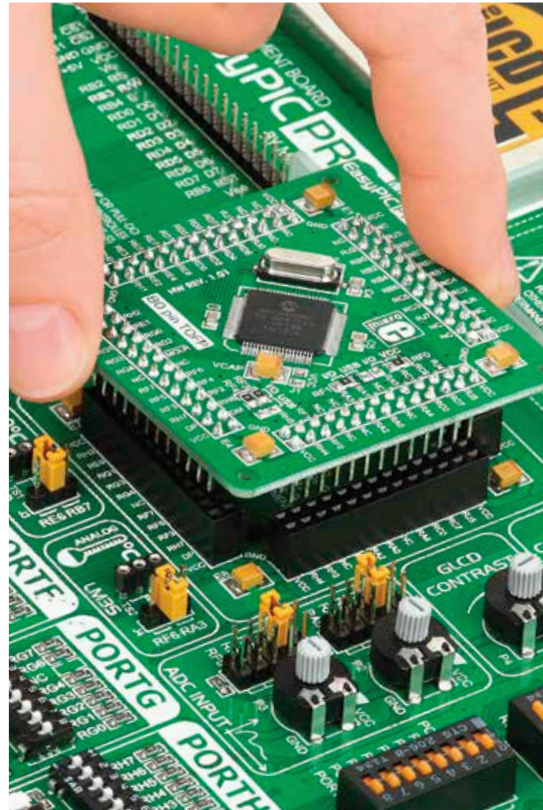

2 Figure 4-3: Place the MCU card on the socket so the pins are aligned correctly.

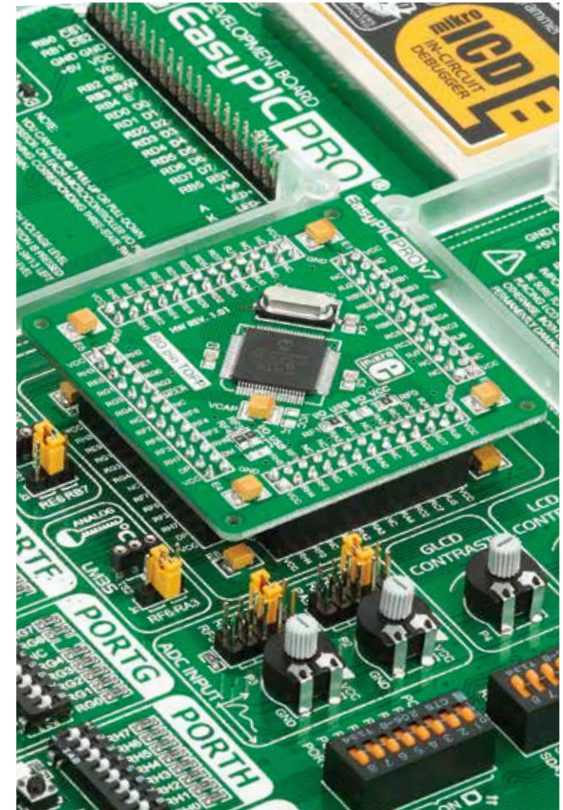

3 Figure 4-4: Properly placed MCU card will have equally leveled pins.

Other supported MCU cards

MikroElektronika currently offers total of five populated MCU cards with different microcontrollers. You can also purchase empty PCB cards that you can populate on your own and solder any supported microcontroller you need in your development. This way your EasyPIC PRO™ v7 board becomes truly flexible and reliable tool for almost any of your PIC® projects. MCU cards can also be used in your final devices. For complete list of currently available MCU cards, please visit the board webpage:

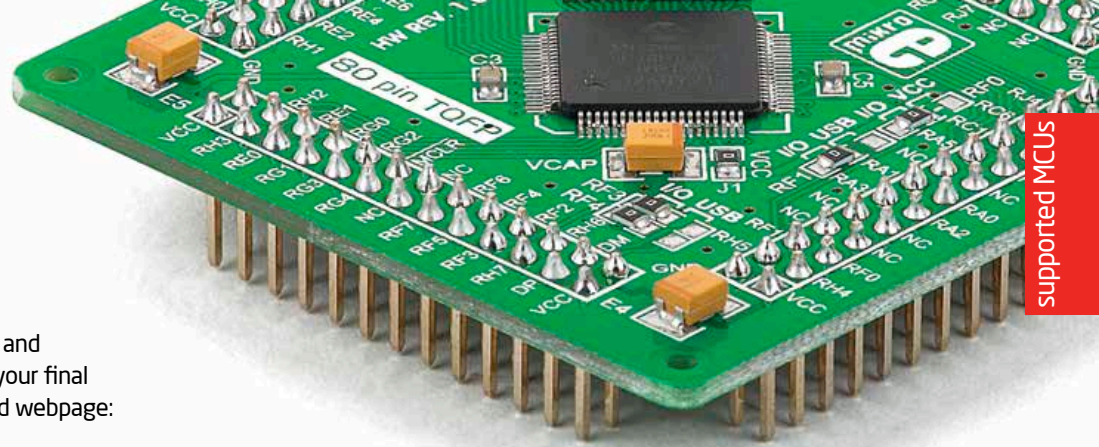

<http://www.mikroe.com/eng/products/view/815/easypic-pro-v7-development-system/>

List of other available populated MCU cards

Besides default MCU card that comes with EasyPIC PRO™ v7, MikroElektronika offers three other **standard 80-pin TQFP cards** with **PIC18F87J50**, **PIC18F8520** and **PIC18F8722** microcontrollers. Additional **80-pin TQFP Ethernet card** with **PIC18F87J60** enables you to utilize the ethernet connector and build ethernet applications easily.

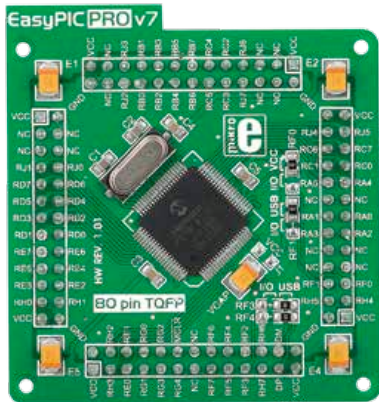

1 Figure 4-5: Standard 80-pin MCU card with **PIC18F87J50**, which supports USB.

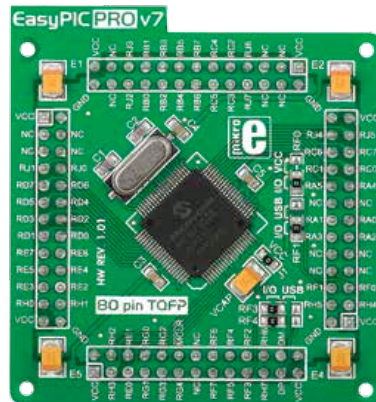

2 Figure 4-6: Standard 80-pin MCU card with **PIC18F8520**.



3 Figure 4-7: Standard 80-pin MCU card with **PIC18F8722**.

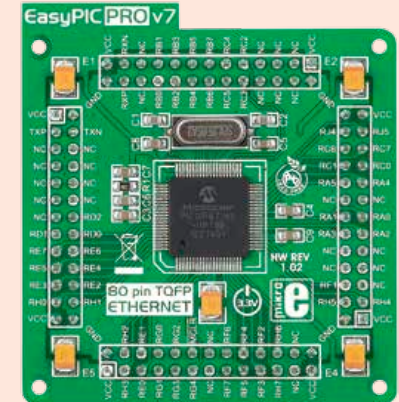

4 Figure 4-8: Ethernet 80-pin MCU card with **PIC18F87J60** microcontroller with internal ethernet module.

with
Ethernet!
support

On-board programmer

What is mikroProg™?

mikroProg™ is a fast USB 2.0 programmer with mikroICD™ hardware In-Circuit Debugger. Smart engineering allows mikroProg™ to support all nearly 100 PIC18 devices in a single programmer. It also features a powerful mikroICD™ debugger which will be of great help in your development. Outstanding performance and easy operation are among its top features.

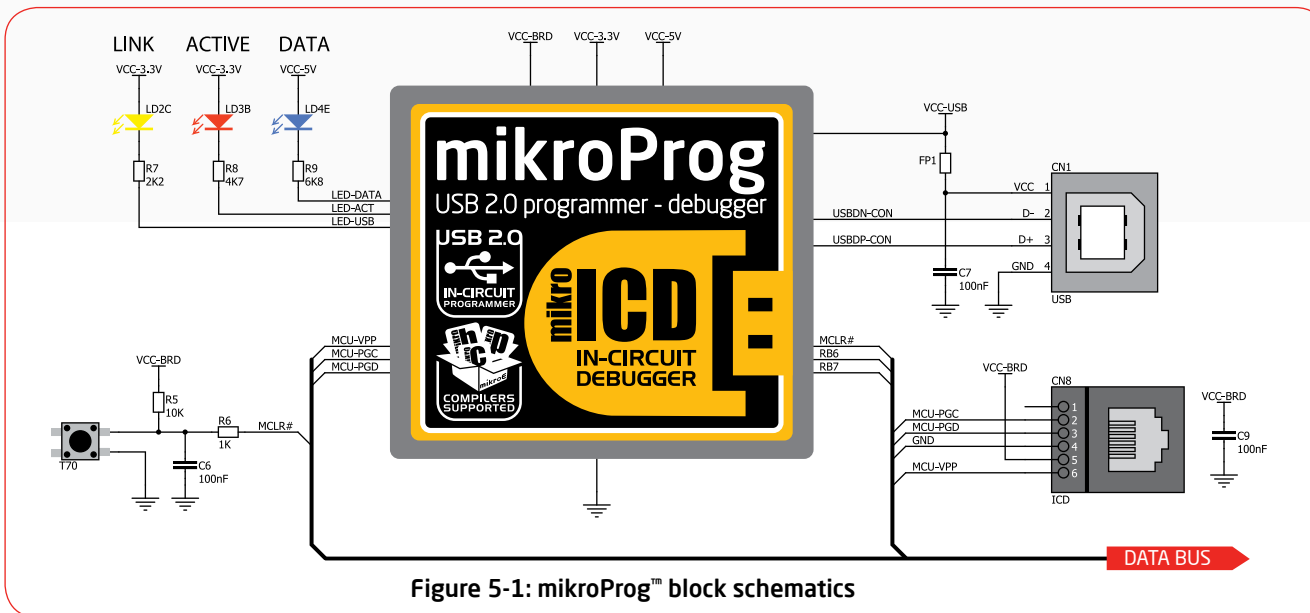

Why so many LEDs?



Three LEDs indicate specific programmer operation. **Link** LED lights up when USB link is established with your PC, **Active** LED lights up when programmer is active. **Data** is on when data is being transferred between the programmer and PC software (compiler or mikroProg Suite™ for PIC®).

How do I start?

In order to start using mikroProg™, and program your microcontroller, you just have to follow two simple steps:

- 1. Install the necessary software**
 - Install USB drivers
 - Install mikroProg Suite™ for PIC® software

- 2. Power up the board, and you are ready to go.**
 - Plug in the programmer USB cable
 - LINK LED should light up.

List of microcontrollers supported with mikroProg™

Here's the list of all microcontrollers which are supported with mikroProg™ programmer and debugger on EasyPIC PRO™ v7 board. The list may grow with each new release of mikroProg Suite™ for PIC® software.

<i>PIC18F83J90</i>	<i>PIC18F87J93</i>	<i>PIC18F8527</i>	<i>PIC18F8490</i>	<i>PIC18F65J15</i>	<i>PIC18F44J11</i>
<i>PIC18F84J90</i>	<i>PIC18F86J50</i>	<i>PIC18F6620</i>	<i>PIC18F8520</i>	<i>PIC18F66J10</i>	<i>PIC18F45J11</i>
<i>PIC18F85J90</i>	<i>PIC18F86J55</i>	<i>PIC18F6720</i>	<i>PIC18F8620</i>	<i>PIC18F66J15</i>	<i>PIC18F46J11</i>
<i>PIC18F83J11</i>	<i>PIC18F87J50</i>	<i>PIC18F6310</i>	<i>PIC18F8720</i>	<i>PIC18F67J10</i>	<i>PIC18F44J50</i>
<i>PIC18F84J11</i>	<i>PIC18F85J50</i>	<i>PIC18F6410</i>	<i>PIC18F8393</i>	<i>PIC18F66J11</i>	<i>PIC18F45J50</i>
<i>PIC18F85J11</i>	<i>PIC18F86J60</i>	<i>PIC18F6390</i>	<i>PIC18F8493</i>	<i>PIC18F66J16</i>	<i>PIC18F46J50</i>
<i>PIC18F85J10</i>	<i>PIC18F86J65</i>	<i>PIC18F6490</i>	<i>PIC18F63J90</i>	<i>PIC18F67J11</i>	<i>PIC18F67J60</i>
<i>PIC18F85J15</i>	<i>PIC18F87J60</i>	<i>PIC18F6585</i>	<i>PIC18F64J90</i>	<i>PIC18F65J50</i>	<i>PIC18LF43K22</i>
<i>PIC18F86J10</i>	<i>PIC18F96J60</i>	<i>PIC18F6680</i>	<i>PIC18F65J90</i>	<i>PIC18F66J55</i>	<i>PIC18F46K22</i>
<i>PIC18F86J15</i>	<i>PIC18F96J65</i>	<i>PIC18F8310</i>	<i>PIC18F63J11</i>	<i>PIC18F67J50</i>	<i>PIC18F45K22</i>
<i>PIC18F87J10</i>	<i>PIC18F97J60</i>	<i>PIC18F8410</i>	<i>PIC18F64J11</i>	<i>PIC18F43K20</i>	<i>PIC18F44K22</i>
<i>PIC18F86J11</i>	<i>PIC18F85K22</i>	<i>PIC18F8585</i>	<i>PIC18F65J11</i>	<i>PIC18F44K20</i>	<i>PIC18F43K22</i>
<i>PIC18F86J16</i>	<i>PIC18F86K22</i>	<i>PIC18F8680</i>	<i>PIC18F66J90</i>	<i>PIC18F45K20</i>	<i>PIC18F66J60</i>
<i>PIC18F87J11</i>	<i>PIC18F87K22</i>	<i>PIC18F8622</i>	<i>PIC18F67J90</i>	<i>PIC18F46K20</i>	<i>PIC18F66J65</i>
<i>PIC18F86J90</i>	<i>PIC18F85K90</i>	<i>PIC18F8627</i>	<i>PIC18F66J93</i>	<i>PIC18LF46K22</i>	
<i>PIC18F87J90</i>	<i>PIC18F86K90</i>	<i>PIC18F8722</i>	<i>PIC18F67J93</i>	<i>PIC18LF45K22</i>	
<i>PIC18F86J93</i>	<i>PIC18F87K90</i>	<i>PIC18F8390</i>	<i>PIC18F65J10</i>	<i>PIC18LF44K22</i>	

Programming with ICD2/ICD3

EasyPIC PRO™ v7 is equipped with RJ-12 connector compatible with Microchip® ICD2® and ICD3® external programmers. This way you can override the on-board mikroProg™ programmer and In-Circuit Debugger, and use other programming tools with the board. Insert your ICD programmer cable into connector **CN8**, as shown in images **1** and **2**.

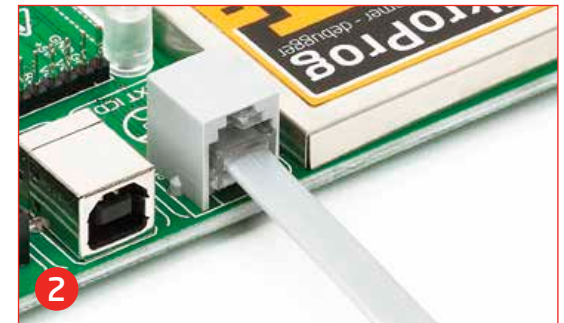
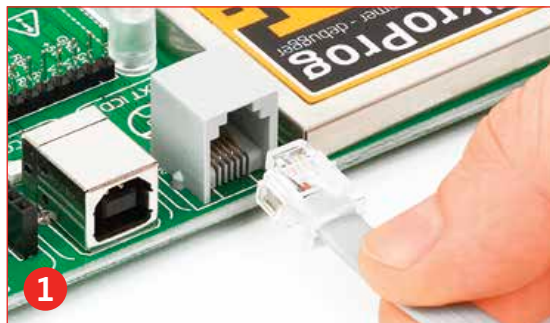

Installing programmer drivers

On-board mikroProg™ requires drivers in order to work. Drivers can be found on the link below:



http://www.mikroe.com/downloads/get/1201/mikroprog_for_pic_drivers_v200.zip

When you locate the drivers, please extract files from the ZIP archive. Folder with extracted files contains sub folders with drivers for different operating systems. Depending on which operating system you use, choose adequate folder and open it.



Vista 32bit, Win
2008 32 bit,
Windows 7 32 bit



Vista 64bit, Win
2008 64 bit,
Windows 7 64 bit



Win 98



Win 2000, XP,
2003 32-bit



Win XP, 2003
64-bit



installing_usb_dri
vers.pdf

In the opened folder you should be able to locate the driver setup file. Double click on setup file to begin installation of the programmer drivers.



USB18PRG-Vista-
x64.EXE

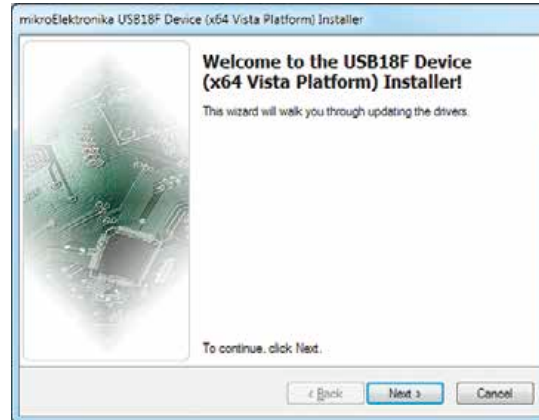

Step 1 - Start Installation

Welcome screen of the installation. Just click on **Next** button to proceed.

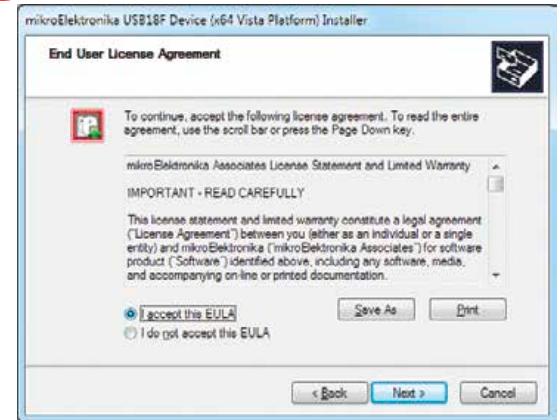

Step 2 - Accept EULA

Carefully read **End User License Agreement**. If you agree with it, click **Next** to proceed.

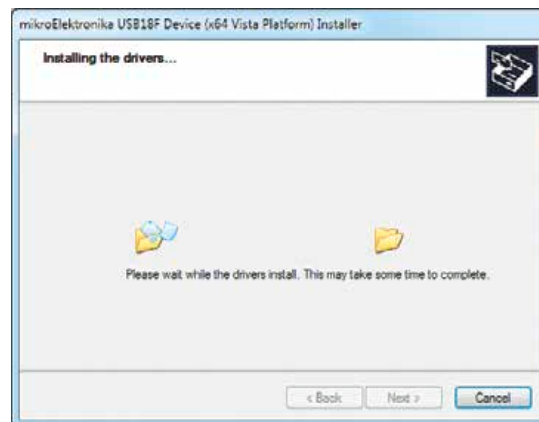

Step 3 - Installing drivers

Drivers are installed automatically in a matter of seconds.



Step 4 - Finish installation

You will be informed if the drivers are installed correctly. Click on **Finish** button to end installation process.

Programming software

mikroProg Suite™ for PIC®

On-board **mikroProg™** programmer requires special programming software called **mikroProg Suite™ for PIC®**. This software is used for programming all of Microchip® microcontroller families, including PIC10, PIC12, PIC16, PIC18, dsPIC30/33, PIC24 and PIC32. Software has intuitive interface and **SingleClick™** programming technology. To begin, first locate the installation archive on our website:



http://www.mikroe.com/downloads/get/1201/mikroprog_suite_for_pic_v229.zip

After downloading, extract the package and double click the executable setup file, to start installation.

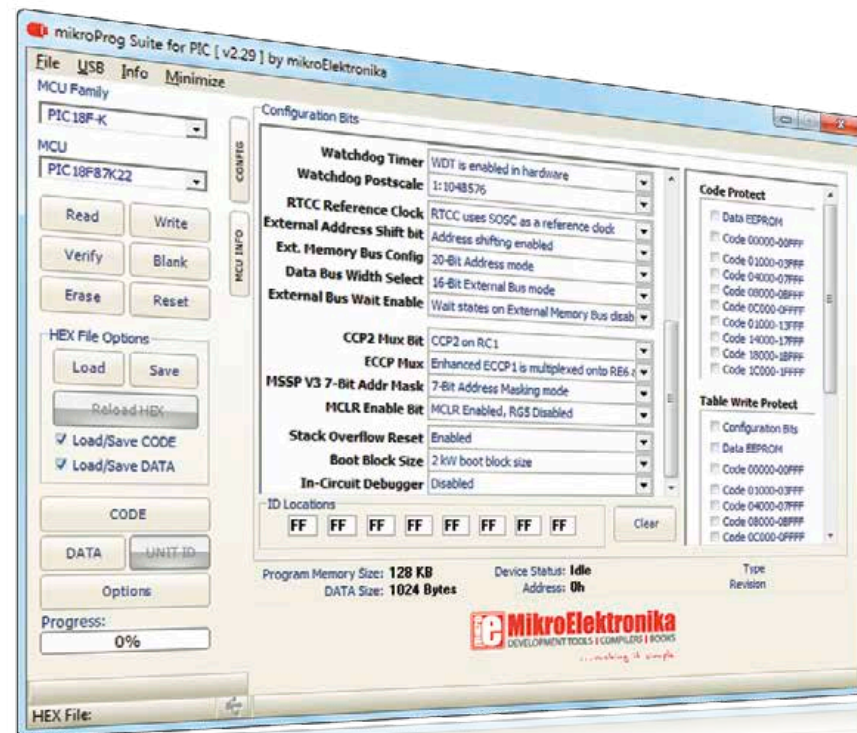

Installation wizard - 6 simple steps



Step 1 - Start Installation



Step 2 - Accept EULA and continue



Step 3 - Install for All users

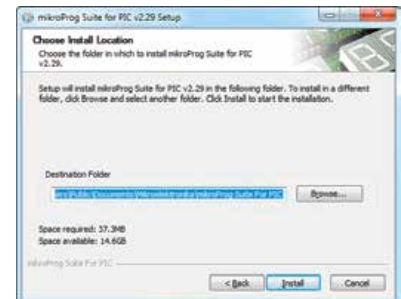

Step 4 - Choose destination folder

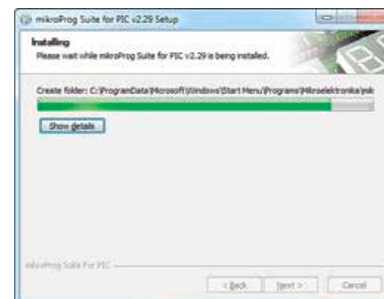

Step 5 - Installation in progress

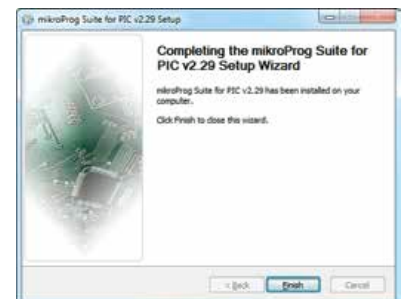

Step 6 - Finish Installation

mikroICD™ - In Circuit Debugger

What is Debugging?

Every developer comes to a point where he has to monitor the code execution in order to find errors in the code, or simply to see if everything is going as planned. This hunt for bugs, or errors in the code is called **debugging**. There are two ways to do this: one is **the software simulation**, which enables you to simulate what is supposed to be happening on the microcontroller as your code lines are executed, and the other, most reliable one, is monitoring the code execution on the chip itself. And this latter one is called **In-Circuit debugging**. "In-Circuit" means that it is the real deal - code executes right on the target device.

What is mikroICD™?

The on-board **mikroProg™** programmer supports **mikroICD™** - a highly effective tool for a **Real-Time debugging** on hardware level. The mikroICD™ debugger enables you to execute your program on the host PIC microcontroller and view variable values, Special Function Registers (SFR), RAM, CODE and EEPROM memory along with the mikroICD™ code execution on hardware. Whether you are a beginner, or a professional, this powerful tool, with intuitive interface and convenient set of commands will enable you to track down bugs quickly. mikroICD™ is one of the fastest, and most reliable debugging tools on the market.

Supported Compilers

All MikroElektronika compilers, **mikroC**, **mikroBasic** and **mikroPascal** for PIC®, dsPIC® and PIC32® natively support mikroICD™. Specialized mikroICD DLL module allows compilers to exploit the full potential of fast hardware debugging. Along with compilers, make sure to install the appropriate **programmer drivers** and **mikroProg Suite for PIC®** programming software, as described on **pages 14 and 15**.

How do I use the debugger?

When you build your project for debugging, and program the microcontroller with this HEX file, you can start the debugger using **[F9]** command. Compiler will change layout to debugging view, and a blue line will mark where code execution is currently paused. Use **debugging toolbar** in the **Watch Window** to guide the program execution, and stop anytime. Add the desired variables to Watch Window and monitor their values. Complete guide to using mikroICD™ with your compiler is provided with the EasyPIC PRO™ v7 package.



Figure 5-2: mikroICD™ manual explains debugging thoroughly

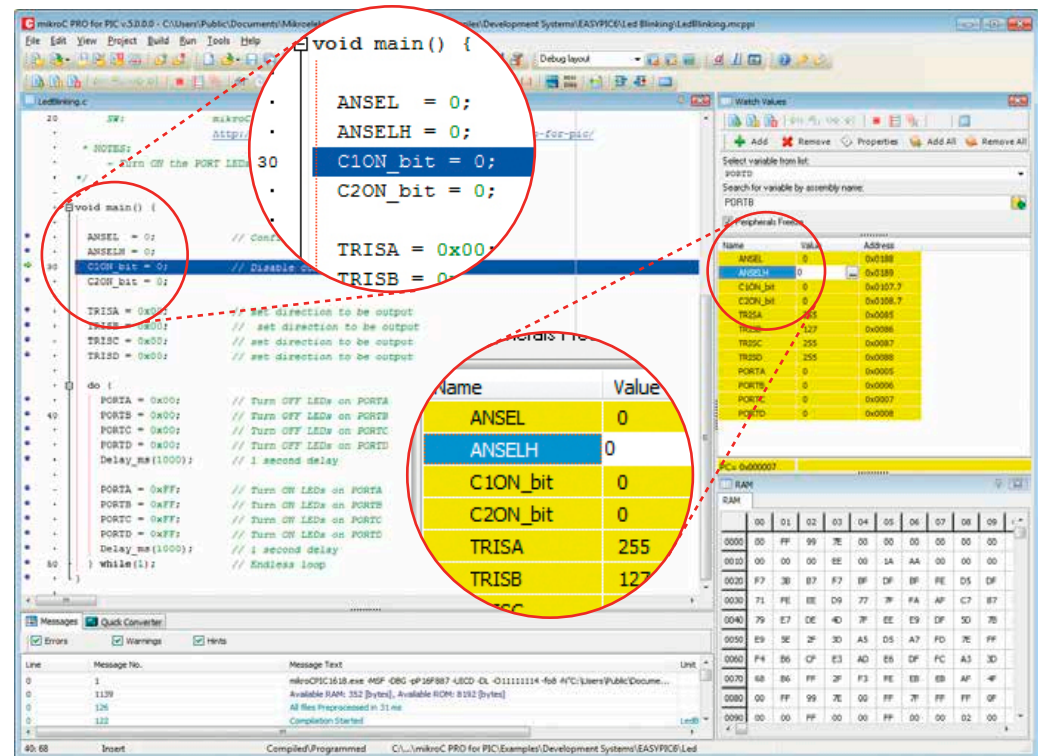
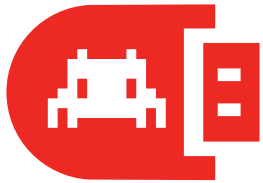













Figure 5-3: mikroC PRO for PIC® compiler in debugging view, with SFR registers in Watch Window



mikroCD™ commands



Here is a short overview of which debugging commands are supported in MikroElektronika compilers. You can see what each command does, and what are their shortcuts when you are in debugging mode. It will give you some general picture of what your debugger can do.

Toolbar Icon	Command Name	Shortcut	Description
	Start Debugger	[F9]	Starts Debugger.
	Run/Pause Debugger	[F6]	Run/Pause Debugger.
	Stop Debugger	[Ctrl + F2]	Stops Debugger.
	Step Into	[F7]	Executes the current program line, then halts. If the executed program line calls another routine, the debugger steps into the routine and halts after executing the first instruction within it.
	Step Over	[F8]	Executes the current program line, then halts. If the executed program line calls another routine, the debugger will not step into it. The whole routine will be executed and the debugger halts at the first instruction following the call.
	Step Out	[Ctrl + F8]	Executes all remaining program lines within the subroutine. The debugger halts immediately upon exiting the subroutine.
	Run To Cursor	[F4]	Executes the program until reaching the cursor position.
	Toggle Breakpoint	[F5]	Toggle breakpoints option sets new breakpoints or removes those already set at the current cursor position.
	Show/Hide breakpoints	[Shift+F4]	Shows/Hides window with all breakpoints
	Clears breakpoints	[Shift+Ctrl+F5]	Delete's selected breakpoints
	Jump to interrupt	[F2]	Opens window with available interrupts (doesn't work in mikroCD™ mode)

Input/Output Group

One of the most distinctive features of EasyPIC PRO™ v7 are its Input/Output PORT groups. They add so much to the connectivity potential of the board.

Everything is grouped together

It took us a while to realize that having PORT **headers**, PORT **buttons** and PORT **LEDs** next to each other, and grouped together, makes development easier, and the entire EasyPIC PRO™ v7 cleaner and well organized. We have also provided an **additional PORT headers** on the right side of the board, so you can access any pin you want from that side of the board too.

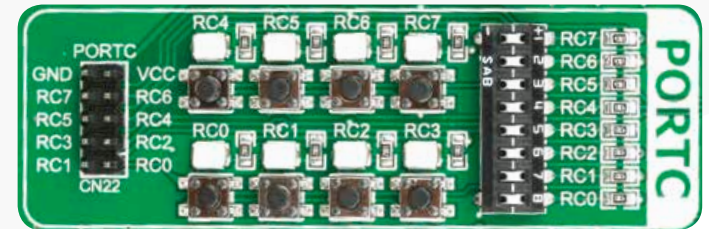

Figure 6-1: I/O group contains PORT headers, tri-state pull up/down DIP switch, buttons and LEDs all in one place

Tri-state pull-up/down DIP switches



Tri-state DIP switches, like **SW3** on **Figure 6-2**, are used to enable 4K7 pull-up or pull-down resistor on any desired port pin. Each of these switches has three states:

1. **middle position** disables both pull-up and pull-down feature from the PORT pin
2. **up position** connects the resistor in pull-up state to the selected pin
3. **down position** connects the resistor in pull-down state to the selected PORT pin.

Figure 6-2: Tri-state DIP switch on PORTC

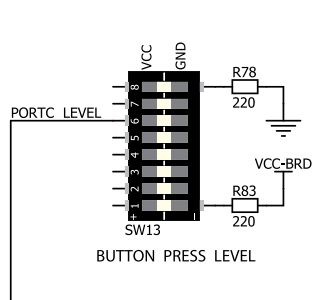

Button press level tri-state DIP switch is used to determine which logic level will be applied to port pins when buttons are pressed

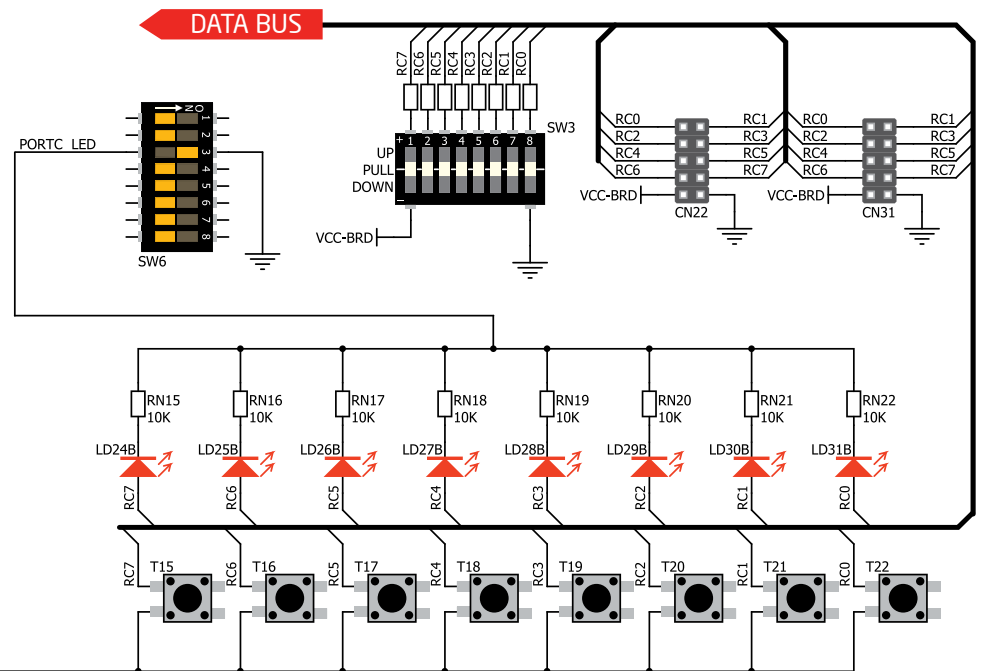
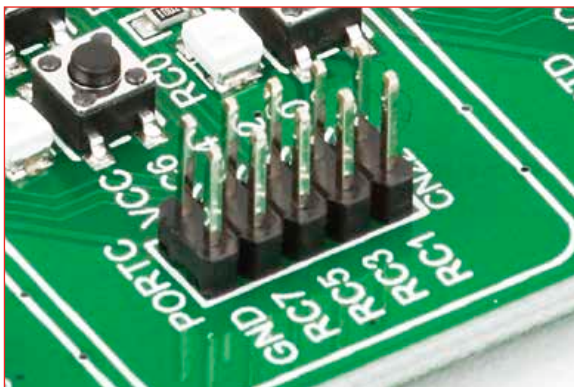

Figure 6-3: Schematic of the single I/O group connected to microcontroller PORTC



Headers

With enhanced connectivity as one of the key features of EasyPIC PRO™ v7, we have provided **two connection headers for each PORT**. I/O PORT group contains one male IDC10 2x5 header (like **CN22 Figure 6-3**). There is **one more IDC10 header** available on the right side of the board, next to DIP switches. These headers are all compatible with over 70 MikroElektronika accessory boards, and enable simple connection.

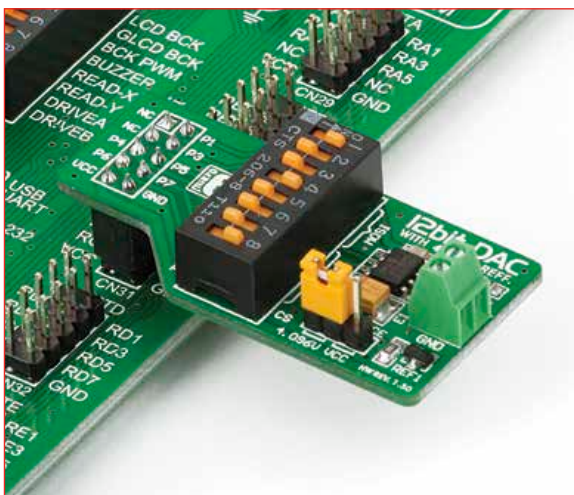
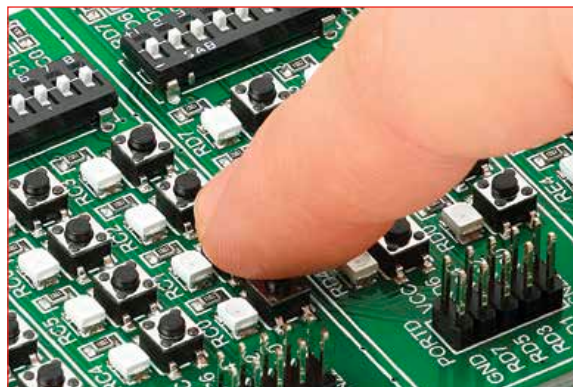

Figure 6-4: IDC10 male headers enable easy connection with MikroElektronika accessory boards



Buttons

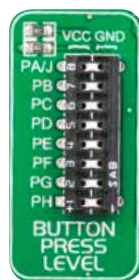
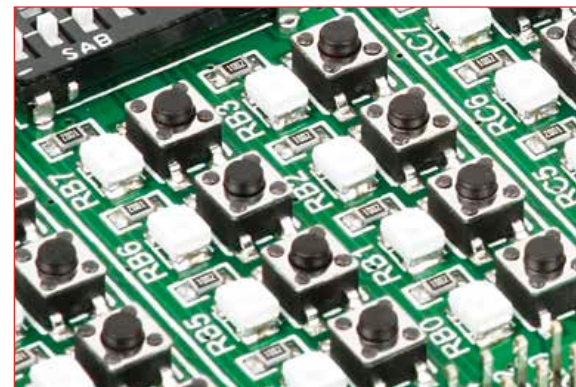

Figure 6-5: Button press level DIP switches (tri-state)

The logic state of all microcontroller digital inputs may be changed using **push buttons**. Tri-state DIP switch **SW13** is available for selecting which logic state will be applied to corresponding MCU pin when button is pressed, for each I/O port separately. If you, for example, place **SW13.3** in **VCC** position, then pressing of any push button in PORTC I/O group will apply logical one to the appropriate microcontroller pin. The same goes for **GND**. If the DIP switch is in the middle position, then all push buttons of the associated PORT will be disconnected from the microcontroller pin.

Reset Button

In the far upper right section of the board, there is a **RESET button**, which can be used to manually reset the microcontroller. This button is directly connected to the microcontroller **MCLR pin**.



LEDs

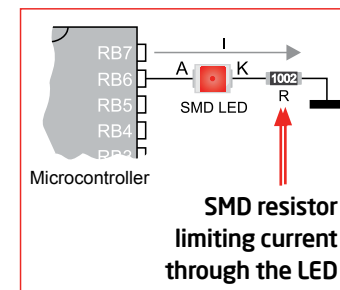

LED (Light-Emitting Diode) is a highly efficient electronic light source. When connecting LEDs, it is necessary to place a current limiting resistor in series so that LEDs are provided with

the current value specified by the manufacturer. The current varies from 0.2mA to 20mA, depending on the type of the LED and the manufacturer. The EasyPIC PRO v7 board uses low-current LEDs with typical current consumption of 0.2mA or 0.3mA, depending of VCC voltage selection. Board contains 69 LEDs which can be used for visual indication of the logic state on PORT pins. An active LED indicates that a logic high (1) is present on the pin. In order to enable PORT LEDs, it is necessary to enable the corresponding DIP switch on **SW6 (Figure 6-6)**.

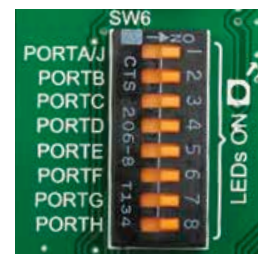

Figure 6-6: SW6.1 through SW6.4 switches are used to enable PORT LEDs

mikroBUS™ sockets

Easier connectivity and simple configuration are imperative in modern electronic devices. Success of the USB standard comes from its simplicity of usage and high and reliable data transfer rates. As we in MikroElektronika see it, Plug-and-Play devices with minimum settings are the future in embedded world too. This is why our engineers have come up with a simple, but brilliant pinout with lines that most of today's accessory boards require, which almost completely eliminates the need of additional hardware settings. We called this new standard the **mikroBUS™**. EasyPIC PRO™ v7 is a development board which supports mikroBUS™ with three on-board sockets. As you can see, there are no additional DIP switches, or jumper selections. Everything is already routed to the most appropriate pins of the microcontroller sockets.

mikroBUS™ host connector

Each mikroBUS™ host connector consists of two 1x8 female headers containing pins that are most likely to be used in the target accessory board. There are three groups of communication pins: **SPI**, **UART** and **I²C** communication. There are also single pins for **PWM**, **Interrupt**, **Analog input**, **Reset** and **Chip Select**. Pinout contains two power groups: **+5V** and **GND** on one header and **+3.3V** and **GND** on the other 1x8 header.

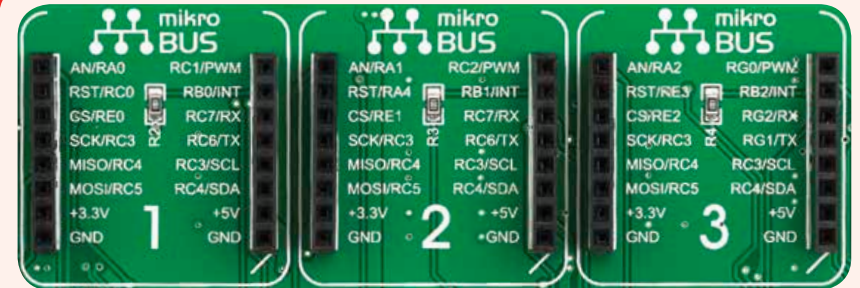

mikroBUS™ pinout explained

- AN** - Analog pin
- RST** - Reset pin
- CS** - SPI Chip Select line
- SCK** - SPI Clock line
- MISO** - SPI Slave Output line
- MOSI** - SPI Slave Input line
- +3.3V** - VCC-3.3V power line
- GND** - Reference Ground
- PWM** - PWM output line
- INT** - Hardware Interrupt line
- RX** - UART Receive line
- TX** - UART Transmit line
- SCL** - I2C Clock line
- SDA** - I2C Data line
- +5V** - VCC-5V power line
- GND** - Reference Ground

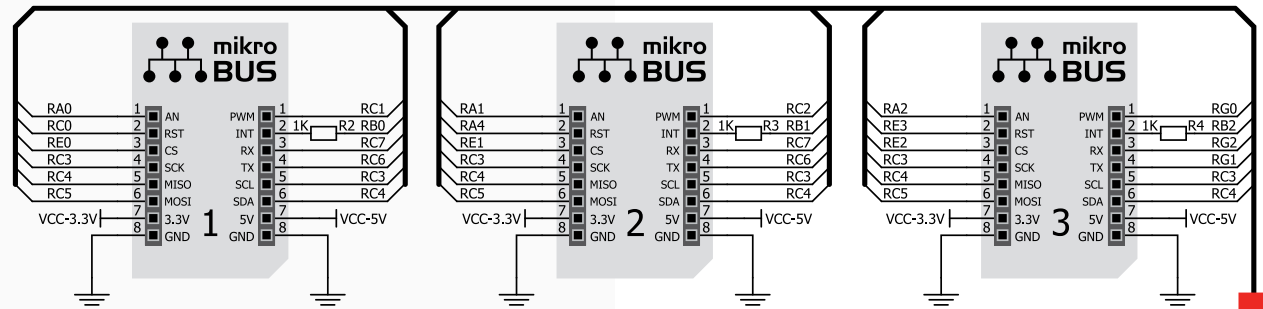
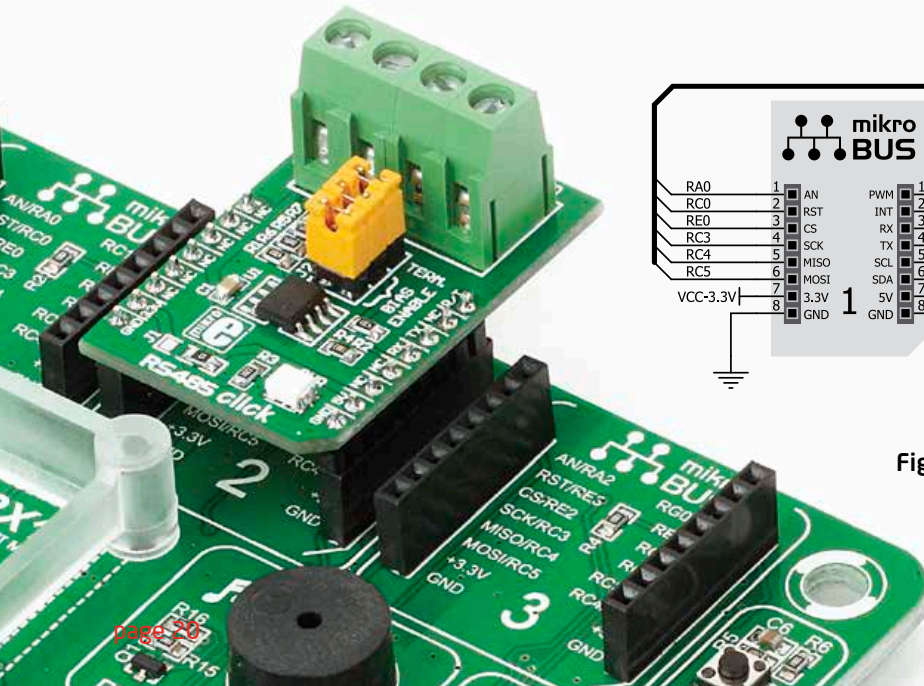
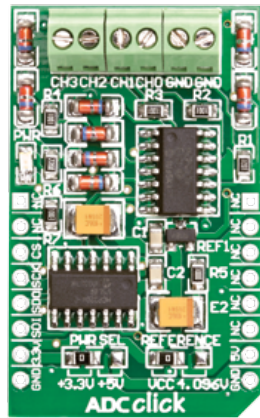
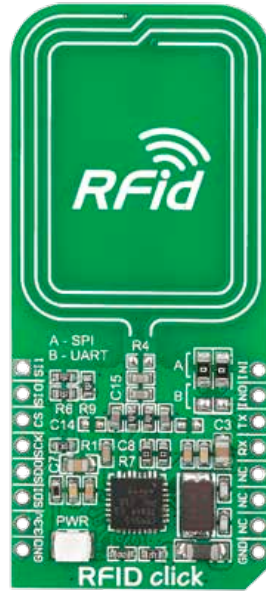

Figure 7-1: Connection schematics of on-board mikroBUS™ host sockets



ADC click™



RFID click™



BlueTooth click™



MP3 click™



GSM click™

Click Boards™ are plug-n-play!

MikroElektronika portfolio of over 200 accessory boards is now enriched by an additional set of mikroBUS™ compatible **Click Boards™**. Almost each month several new Click boards™ are released. It is our intention to provide the community with as much of these boards as possible, so you will be able to expand your EasyPIC™ PRO v7 with additional functionality with literally zero

hardware configuration. Just plug and play. Visit the Click boards™ webpage for the complete list of available boards:



<http://www.mikroe.com/click/>

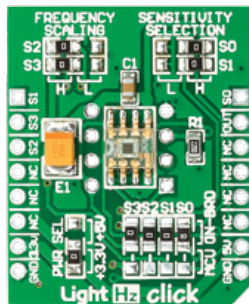

LightHz click™



microSD click™

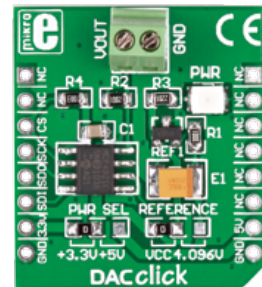

DAC click™



DIGIPOT click™

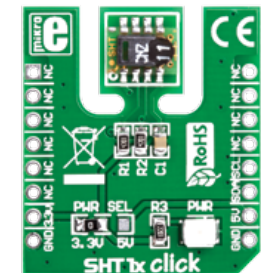

SHT1x click™

EasyPIC PRO^{v7}

UART via RS-232



Enabling RS-232



In order to enable RS-232 communication, you must push **SW5.3** (RG1) and **SW5.4** (RG2) to **ON** position. This connects the **RX** and **TX** lines to appropriate microcontroller pins and its second UART module.

The **UART** (universal asynchronous receiver/transmitter) is one of the most common ways of exchanging data between the MCU and peripheral components. It is a serial protocol with separate transmit and receive lines, and can be used for full-duplex communication. Both sides must be initialized with the same baudrate, otherwise the data will not be received correctly.

RS-232 serial communication is performed through a 9-pin SUB-D connector and the microcontroller UART module. In order to enable this communication, it is necessary to establish a connection between **RX** and **TX** lines on SUB-D connector and the same pins on the target microcontroller using DIP switches. Since RS-232 communication voltage levels are different than microcontroller logic levels, it is necessary to use a RS-232 Transceiver circuit, such as **MAX3232** as shown on **Figure 8-1**.

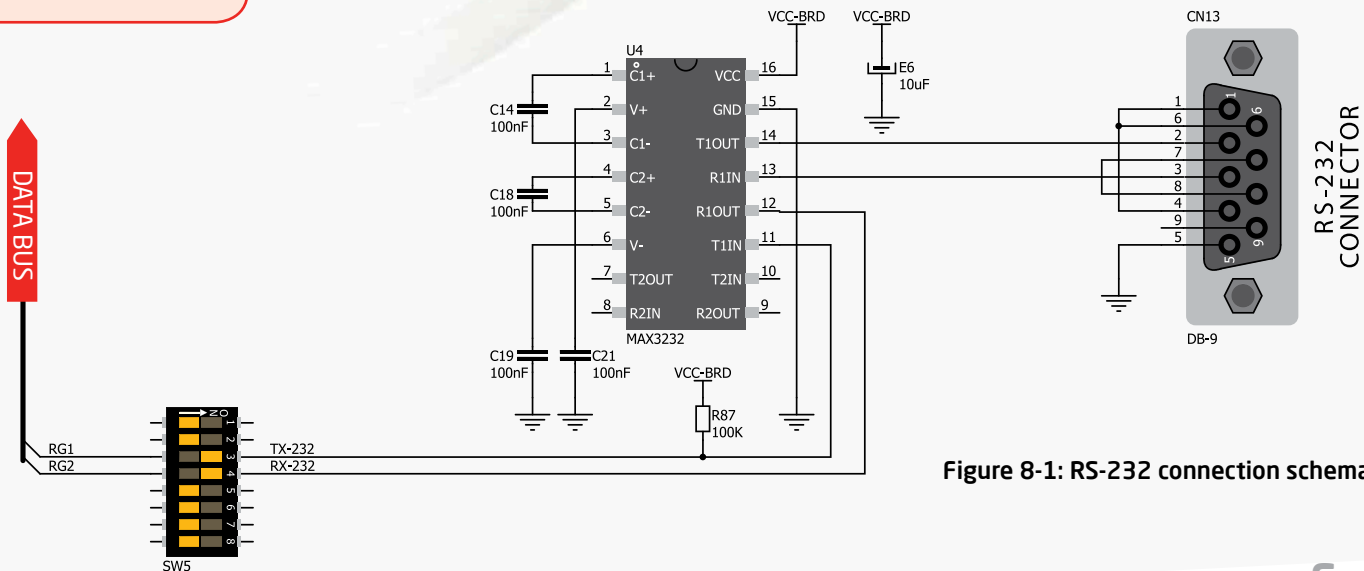

Figure 8-1: RS-232 connection schematics

USB device communication

USB is the acronym for **Universal Serial Bus**. This is a very popular industry standard that defines cables, connectors and protocols used for communication and power supply between computers and other devices. EasyPIC PRO™ v7 contains USB DEVICE connector (**CN9**) which enables microcontrollers that support USB communication to establish a connection with the target host (eg. PC, Laptop, etc). USB data lines coming from the MCU socket are dedicated to USB connector only, and are not available via PORT headers. To enable USB communication, you have to solder SMD jumpers on the MCU card to the appropriate USB position. This only makes sense if the MCU card contains microcontroller with integrated USB controller. One of these cards is **Standard 80-pin MCU card** with **PIC18F87J50** microcontroller.



Enabling USB



Microcontroller with USB support should be soldered to the MCU card with dedicated USB SMD jumpers. Make sure to solder **RF1**, **RF3** and **RF4** jumpers to USB position in order to connect USB lines to USB connector.

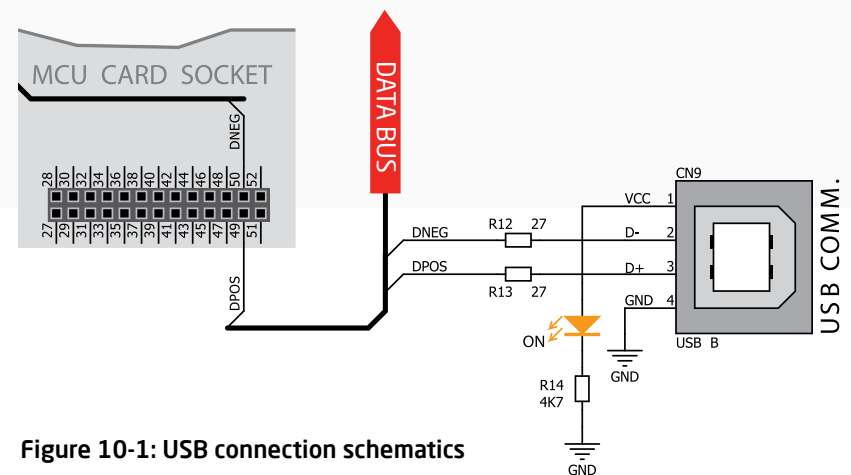

Figure 10-1: USB connection schematics



Ethernet communication

Ethernet is a popular computer networking technology for local area networks (LAN). Systems communicating over Ethernet divide a stream of data into individual packets called frames. Each frame contains source and destination addresses and error-checking data so that damaged data can be detected and re-transmitted. EasyPIC PRO™ v7 features standard **RJ-45** connector which enables microcontrollers that support Ethernet communication to establish a connection with a computer, router or other devices. All four ethernet lines (TPOUT+, TPOUT-, TPIN+ and TPIN-) are routed to the MCU card socket. Only microcontrollers containing embedded ethernet module soldered to **100-pin** or **80-pin TQFP Ethernet MCU cards** can use these lines and utilize ethernet connector. Additional signalization LEDs are available on the board.



Enabling Eth. LEDs



In order to enable ethernet LEDs, you must enable **SW5.5** (RA0) and **SW5.6** (RA1) DIP switches. This connects the **LEDA** and **LEDB** lines to appropriate microcontroller pins.

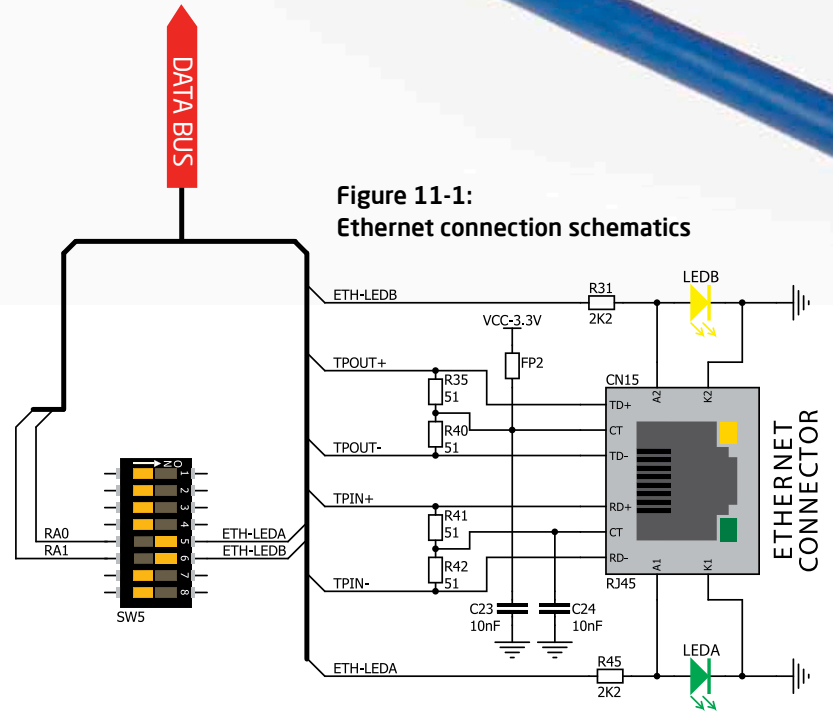

Figure 11-1:
Ethernet connection schematics

LCD 2x16 characters

Liquid Crystal Displays or **LCDs** are cheap and popular way of representing information to the end user of some electronic device. Character LCDs can be used to represent standard and custom characters in the predefined number of fields. EasyPIC PRO™ v7 provides the connector and the necessary interface for supporting **2x16 character LCDs** in 4-bit mode. This type of display has two rows consisted of 16 character fields. Each field is a 7x5 pixel matrix. Communication with the display module is done through **CN14** display connector. Board is fitted with uniquely designed plastic display distancer, which allows the LCD module to perfectly and firmly fit into place.

IMPORTANT: *Make sure to turn off the power supply before placing LCD onto the board. Otherwise your display can be permanently damaged.*

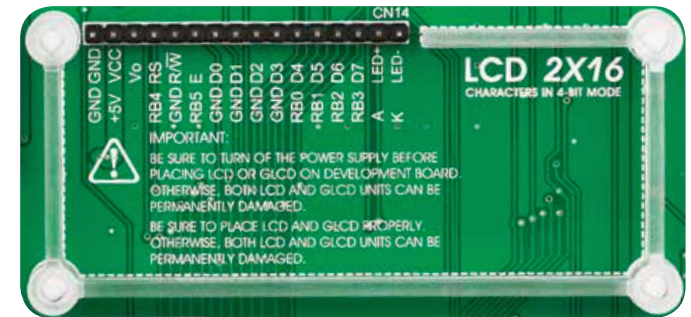

Figure 12-1: On-board LCD 2x16 display connector

Connector pinout explained

GND and VCC - Display power supply lines

V0 - LCD contrast level from potentiometer P1

RS - Register Select Signal line

E - Display Enable line

R/W - Determines whether display is in Read or Write mode. It's always connected to GND, leaving the display in Write mode all the time.

D0-D3 - Display is supported in 4-bit data mode, so lower half of the data byte interface is connected to GND.

D4-D7 - Upper half of the data byte

LED+ - Connection with the backlight LED anode

LED- - Connection with the backlight LED cathode

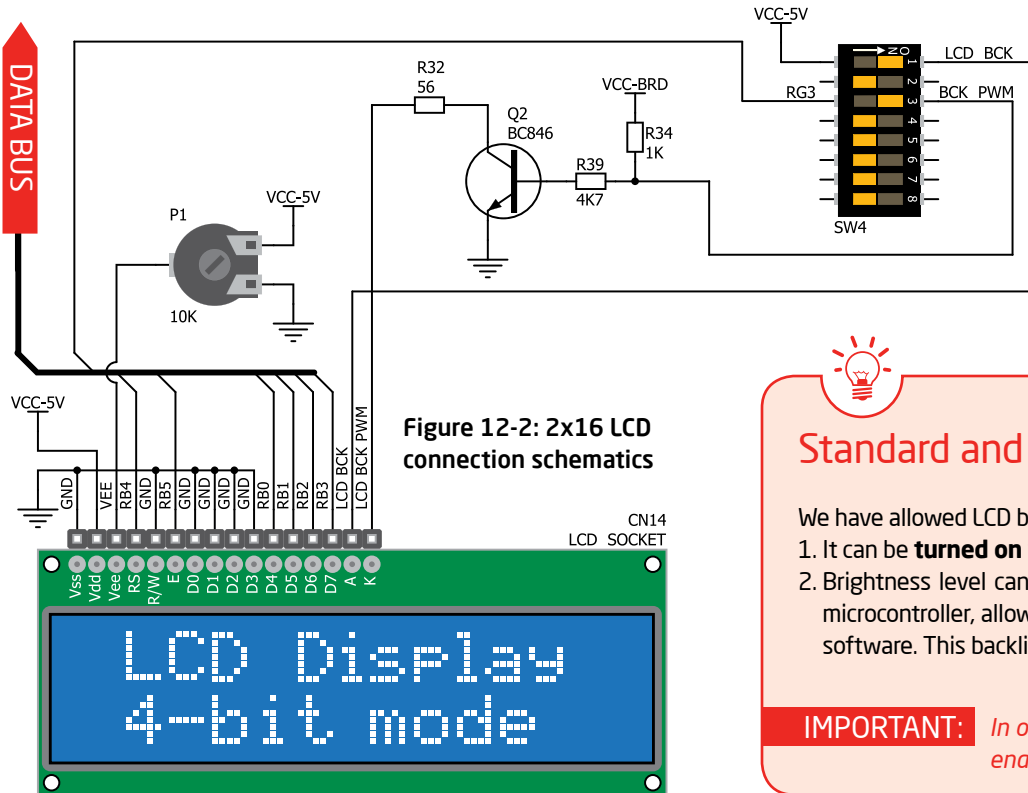

Figure 12-2: 2x16 LCD connection schematics



Standard and PWM-driven backlight

We have allowed LCD backlight to be enabled in two different ways:

1. It can be **turned on with full brightness** using **SW4.1** switch.
2. Brightness level can be determined **with PWM signal** from the microcontroller, allowing you to write custom backlight controlling software. This backlight mode is enabled with **SW4.3** switch.

IMPORTANT: *In order to use PWM backlight both **SW4.1** and **SW4.3** switches must be enabled at the same time.*



GLCD 128x64

Graphical Liquid Crystal Displays, or **GLCDs** are used to display monochromatic graphical content, such as text, images, human-machine interfaces and other content. EasyPIC PRO™ v7 provides the connector and necessary interface for supporting GLCD with resolution of 128x64 pixels, driven by the KS108 or similar display controller. Communication with the display module is done through **CN16** display connector. Board is fitted with uniquely designed plastic display distancer, which allows the

GLCD module to perfectly and firmly fit into place. Display connector is routed to PORTB (control lines) and PORTD (data lines) of the microcontroller sockets. Since PORTB is also used by 2x16 character LCD display, you cannot use both displays simultaneously. You can control the display contrast using dedicated potentiometer **P4**. Display backlight can be enabled with **SW4.2** switch, and PWM-driven backlight with **SW4.3** switch.

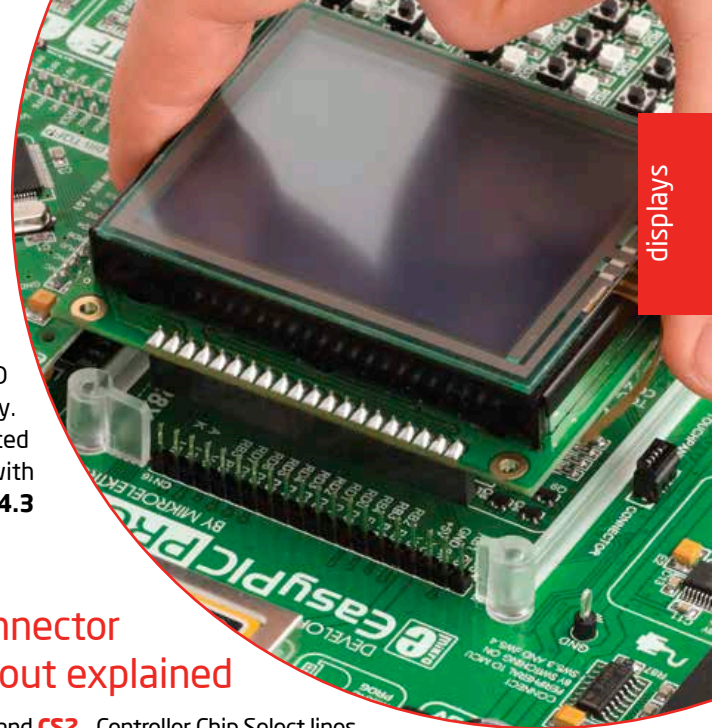

displays

Figure 13-1: GLCD 128x64 connection schematics

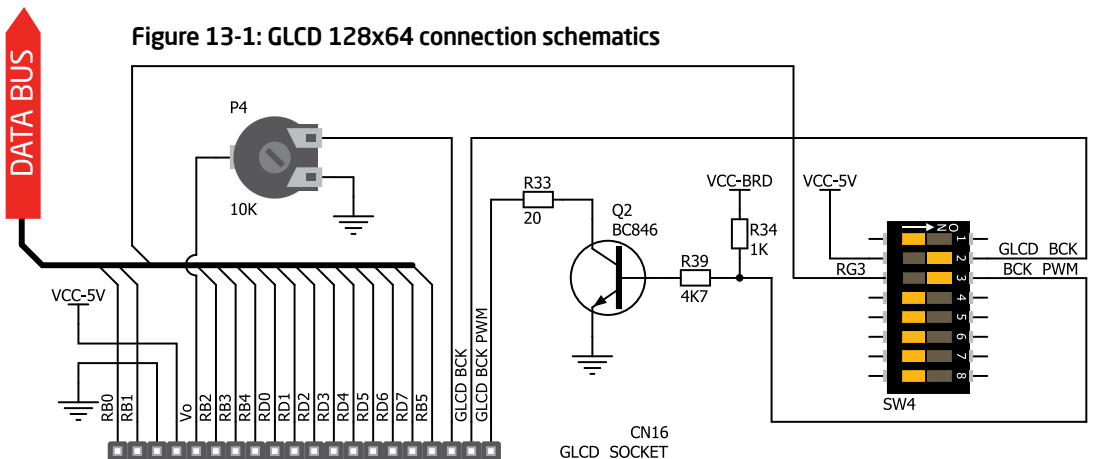

Connector pinout explained

- CS1** and **CS2** - Controller Chip Select lines
- VCC** - +5V display power supply
- GND** - Reference ground
- Vo** - GLCD contrast level from potentiometer P4
- RS** - Data (High), Instruction (Low) selection line
- R/W** - Determines whether display is in Read or Write mode.
- E** - Display Enable line
- D0-D7** - Data lines
- RST** - Display reset line
- Vee** - Reference voltage for GLCD contrast potentiometer P3
- LED+** - Connection with the backlight LED anode
- LED-** - Connection with the backlight LED cathode

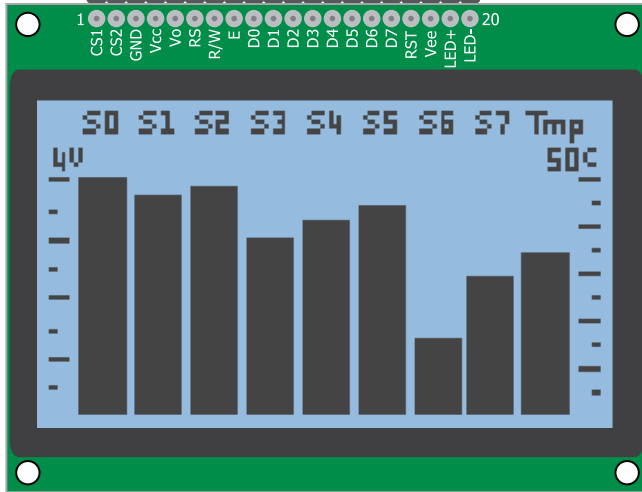

Standard and PWM-driven backlight

As for LCD, we have allowed GLCD backlight to be enabled in two different ways:

1. It can be **turned on with full brightness** using **SW4.2** switch.
2. Brightness level can be determined **with PWM signal** from the microcontroller, allowing you to write custom backlight controlling software. This backlight mode is enabled with **SW4.3** switch.



IMPORTANT: In order to use PWM backlight both **SW4.2** and **SW4.3** switches must be enabled at the same time.

Touchpanel controller

Touchpanel is a glass panel whose surface is covered with two layers of resistive material. When the screen is pressed, the outer layer is pushed onto the inner layer and appropriate controllers can measure that pressure and pinpoint its location. This is how touchpanels can be used as an input devices. EasyPIC PRO™ v7 is equipped with

touchpanel controller and connector for **4-wire resistive touchpanels**. It can very accurately register pressure at a specific point, representing the touch coordinates in the form of analog voltages, which can then be easily converted to X and Y values. Touchpanel is ment to be mounted onto the GLCD display.

Correctly placing the touchpanel cable into the connector

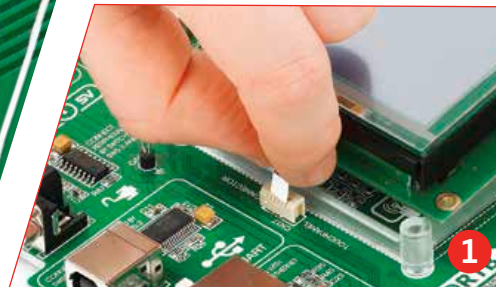

Figure 14-1: Put Touch Panel flat cable in the connector



Figure 14-2: Use a tip of your finger to push it inside

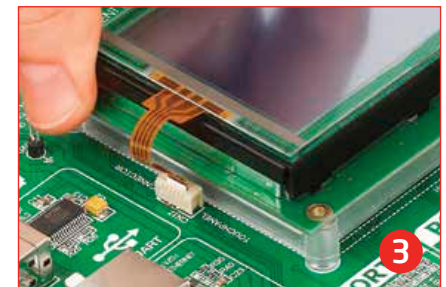

Figure 14-3: Now place GLCD with Touch panel into GLCD socket

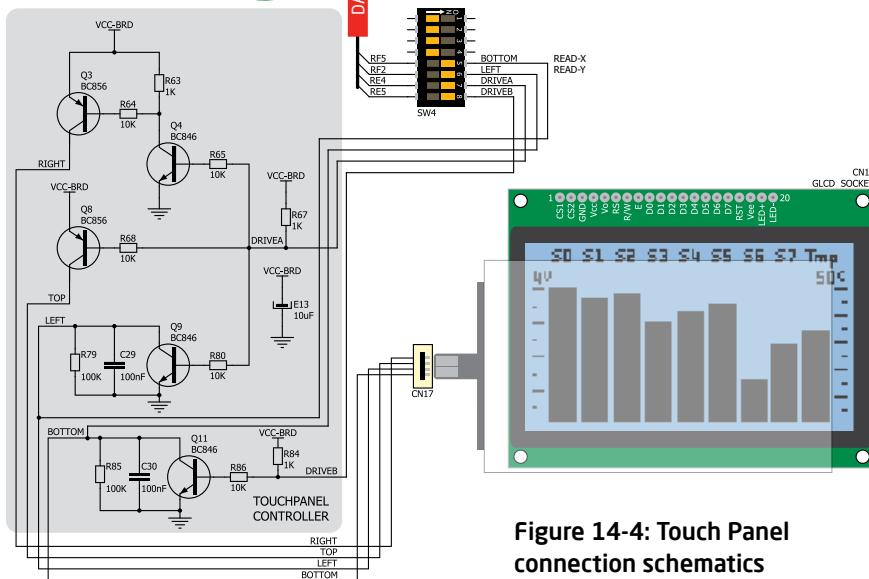

Figure 14-4: Touch Panel connection schematics

Enabling Touch panel

Touchpanel is enabled using **SW4.5**, **SW4.6**, **SW4.7** and **SW4.8** switches. They connect **READ-X** and **READ-Y** lines of the touchpanel with **RF5** and **RF2** analog inputs, and **DRIVEA** and **DRIVEB** with **RE4** and **RE5** digital outputs on microcontroller sockets. Do not connect additional boards or otherwise interfere with these lines while you use touchpanel, because you may corrupt the results of the readings and get inaccurate touch coordinates.

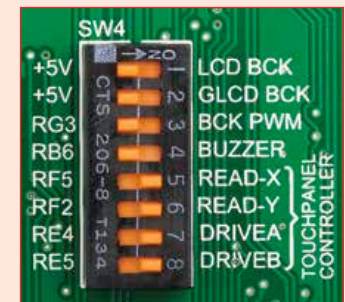

Figure 14-5: Turn on switches 5 through 8 on SW4 to enable Touch panel controller

Piezo Buzzer

Piezoelectricity is the charge which accumulates in certain solid materials in response to mechanical pressure, but also providing the charge to the piezoelectric material causes it to physically deform. One of the most widely used applications of piezoelectricity is the production of sound generators, called piezo buzzers. **Piezo buzzer** is an electric component that comes in different shapes and sizes, which can be used to create sound waves when provided with analog electrical signal. EasyPIC PRO™ v7 comes with piezo buzzer which can be connected to **RB6** microcontroller pin. Connection is established using **SW4.4** DIP switch. Buzzer is driven by transistor **Q1** (Figure 15-1). Microcontrollers can create sound by generating a PWM (Pulse Width Modulated) signal - a **square wave** signal, which is nothing more than a sequence of logic zeros and

ones. Frequency of the square signal determines the pitch of the generated sound, and duty cycle of the signal can be used to increase or decrease the volume in the range from 0% to 100% of the duty cycle. You can generate PWM signal using hardware capture-compare module, which is usually available in most microcontrollers, or by writing a custom software which emulates the desired signal waveform.

Supported sound frequencies

Piezo buzzer's resonant frequency (where you can expect it's best performance) is **3.8kHz**, but you can also use it to create sound in the range between **2kHz** and **4kHz**.

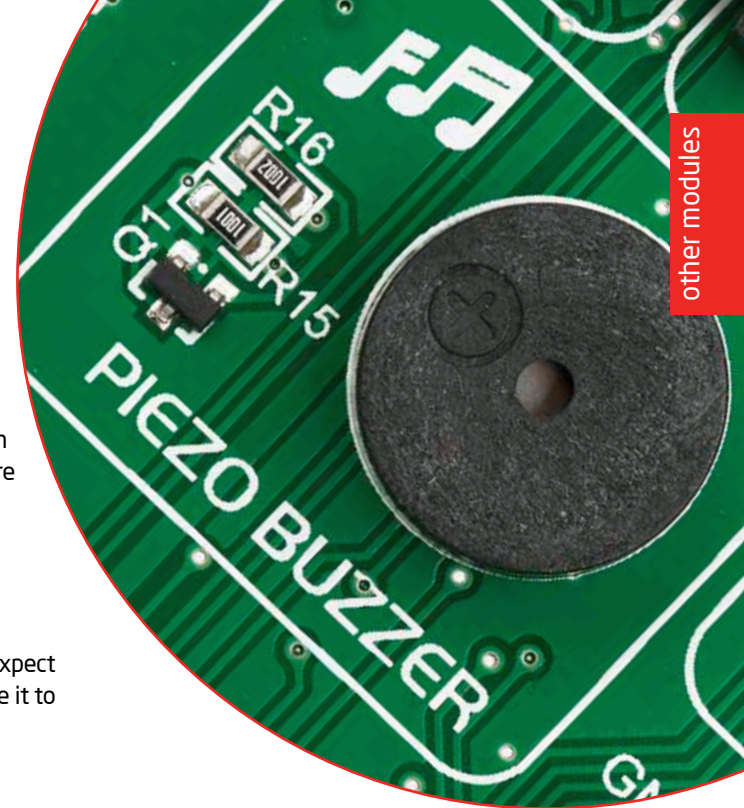
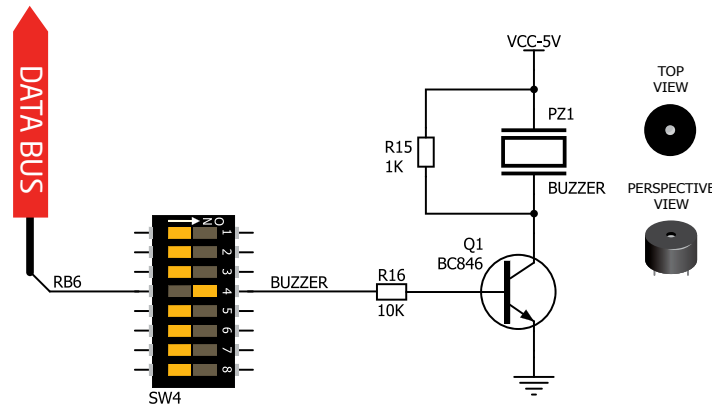

Figure 15-1: Piezo buzzer connected to RB6 microcontroller pin via SW4.4



Enabling Piezo Buzzer

In order to use the on-board Piezo Buzzer in your application, you first have to connect the transistor driver of piezo buzzer to the appropriate microcontroller pin. This is done using **SW4.4** DIP switch. Once the switch is in ON position, it connects the buzzer driver to **RB6** microcontroller pin.

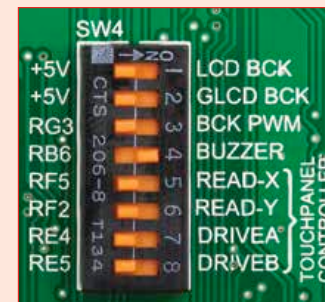

Figure 15-2: Turn ON SW4.4 to connect Piezo buzzer driver to RB6 pin

Freq = 3kHz, Duty Cycle = 50%



Freq = 3kHz,
Volume = 50%

Freq = 3kHz, Duty Cycle = 80%



Freq = 3kHz,
Volume = 80%

Freq = 3kHz, Duty Cycle = 20%



Freq = 3kHz,
Volume = 20%

How to make it sing?

Buzzer starts "singing" when you provide PWM signal from the microcontroller to the buzzer driver. The pitch of the sound is determined by the frequency, and amplitude is determined by the duty cycle of the PWM signal.



DS1820 - Digital Temperature Sensor

DS1820 is a digital temperature sensor that uses **1-wire® interface** for its operation. It is capable of measuring temperatures within the range of -55 to 128°C, and provides $\pm 0.5^\circ\text{C}$ accuracy for temperatures within the range of -10 to 85°C. It requires 3V to 5.5V power supply for stable operation. It takes maximum

of 750ms for the DS1820 to calculate temperature with 9-bit resolution. **1-wire® serial communication** enables data to be transferred over a single communication line, while the process itself is under the control of the master microcontroller. The advantage of such communication is that only one microcontroller pin is used. Multiple

sensors can be connected on the same line. All slave devices by default have a unique ID code, which enables the master device to easily identify all devices sharing the same interface. EasyPIC PRO™ v7 provides a separate socket (**TS1**) for the DS1820. Communication line with the microcontroller is selected with a **J3** jumper.



Enabling DS1820 Sensor

1



Figure 16-1: DS1820 not connected

2



Figure 16-2: DS1820 placed in socket

3



Figure 16-3: DS1820 connected to RB7 pin

4



Figure 16-4: DS1820 connected to RE6 pin

EasyPIC PRO™ v7 enables you to establish 1-wire® communication between **DS1820** and the microcontroller over **RE6** or **RB7** pins. The selection of either of those two lines is done using **J3** jumper. When placing the sensor in the socket make sure that half-circle on the board's silkscreen markings matches the rounded part of the DS1820 sensor. If you accidentally connect the sensor the other way, it may be permanently damaged and you might need to replace it with another one. Make sure to disconnect other peripherals (except 1-wire), LEDs and additional pull-up or pull-down resistors from the interface lines in order not to interfere with signal/data integrity.

Figure 16-5: DS1820 connected to RB7 pin

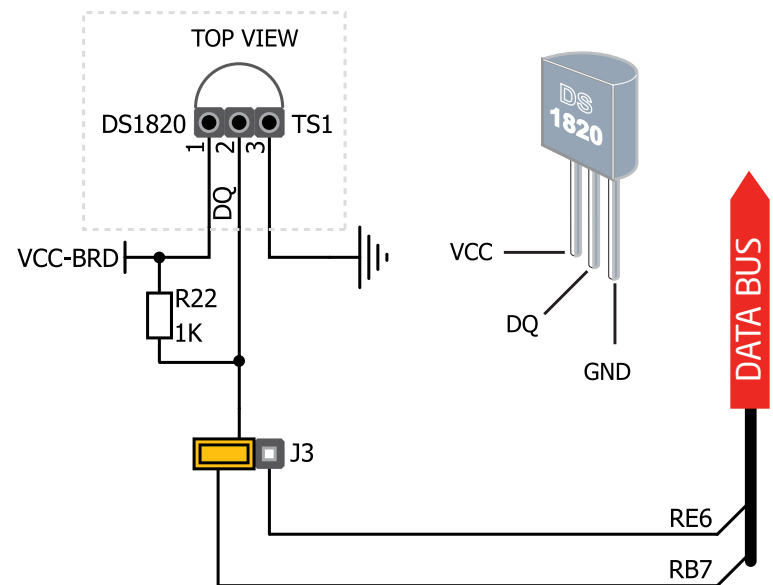

LM35 - Analog Temperature Sensor

The **LM35** is a low-cost precision integrated-circuit temperature sensor, whose output voltage is linearly proportional to the Celsius (Centigrade) temperature. The LM35 thus has an advantage over linear temperature sensors calibrated in ° Kelvin, as the user is not required to subtract a large constant voltage from its output to

obtain convenient Centigrade scaling. The LM35 does not require any external calibration or trimming to provide typical accuracies of $\pm\frac{1}{4}^{\circ}\text{C}$ at room temperature and $\pm\frac{3}{4}^{\circ}\text{C}$ over a full -55 to $+150^{\circ}\text{C}$ temperature range. It has a linear $+10.0\text{ mV}/^{\circ}\text{C}$ scale factor and less than $60\text{ }\mu\text{A}$ current drain. As it draws only $60\text{ }\mu\text{A}$ from its supply, it

has very low self-heating, less than 0.1°C in still air. EasyPIC PRO™ v7 provides a separate socket (**TS2**) for the LM35 sensor in TO-92 plastic packaging. Readings are done with microcontroller using single analog input line, which is selected with a **J4** jumper.

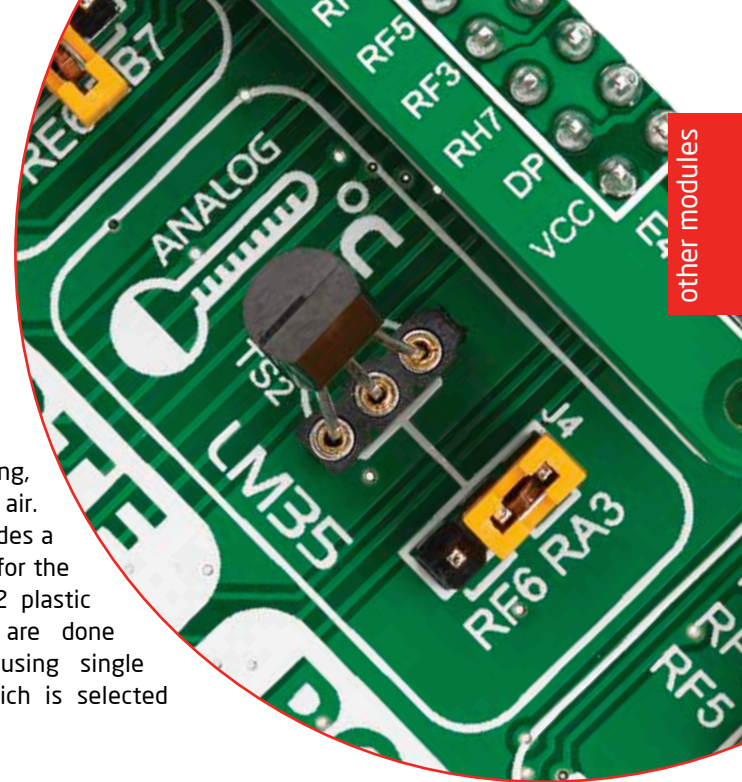

Enabling LM35 Sensor

1



Figure 17-1: LM35 not connected

2



Figure 17-2: LM35 placed in socket

3



Figure 17-3: LM35 connected to RF6 pin

4



Figure 17-4: LM35 connected to RA3 pin

EasyPIC PRO™ v7 enables you to get analog readings from the LM35 sensor using **RA3** or **RF6** microcontroller pins. The selection of either of those two lines is done using **J4** jumper. When placing the sensor in the socket make sure that half-circle on the board's silkscreen markings matches the rounded part of the LM35 sensor. If you accidentally connect the sensor the other way, it can be permanently damaged and you might need to replace it with another one. During the readings of the sensor, make sure that no other device uses the selected analog line, because it may interfere with the readings.

Figure 17-5: LM35 connected to RA3 pin

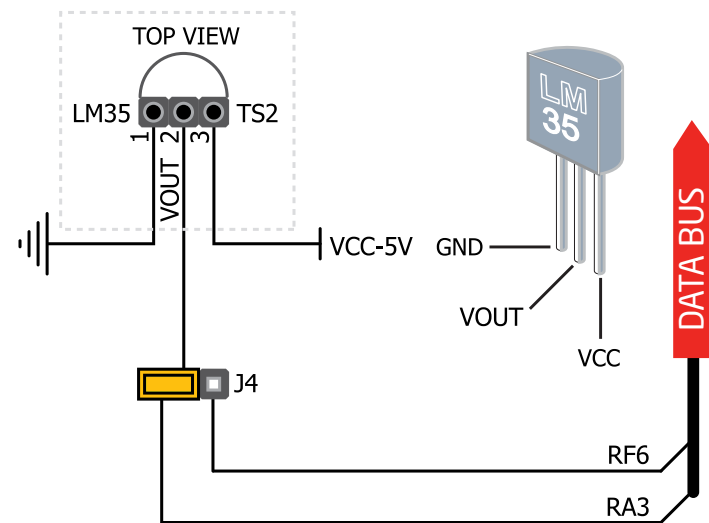

ADC inputs

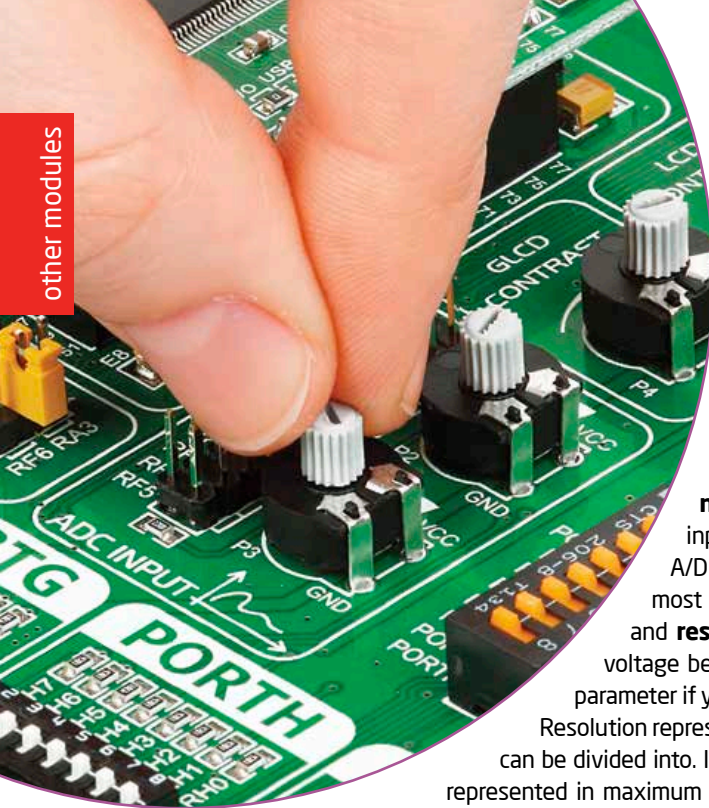

Digital signals have **two discrete states**, which are decoded as **high** and **low**, and interpreted as **logic 1** and **logic 0**. **Analog signals**, on the other hand, are **continuous**, and can have any value within defined range. **A/D converters** are specialized circuits which can convert analog signals (voltages) into a digital representation, usually in form of an **integer number**. The value of this number is **linearly dependent** on the input voltage value. Most microcontrollers nowadays internally have A/D converters connected to one or more input pins. Some of the most important parameters of A/D converters are **conversion time** and **resolution**. Conversion time determines how fast can an analog voltage be represented in form of a digital number. This is an important parameter if you need fast data acquisition. The other parameter is resolution.

Resolution represents the number of discrete steps that supported voltage range can be divided into. It determines the sensitivity of the A/D converter. Resolution is represented in maximum number of bits that resulting number occupies. PIC18F87K22

microcontroller which comes on MCU card with the EasyPIC PRO v7™ board has 12-bit resolution,

meaning that maximum value of conversion can be represented with 12 bits, which converted to integer is

$2^{12}=4096$. This means that supported voltage range, for example from 0-5V, can be divided into 4096 discrete steps of about 1.22mV.

EasyPIC PRO™ v7 provides an interface in form of two potentiometers for simulating analog input voltages that can be routed to any of the 10 supported analog input pins.



Enabling ADC inputs

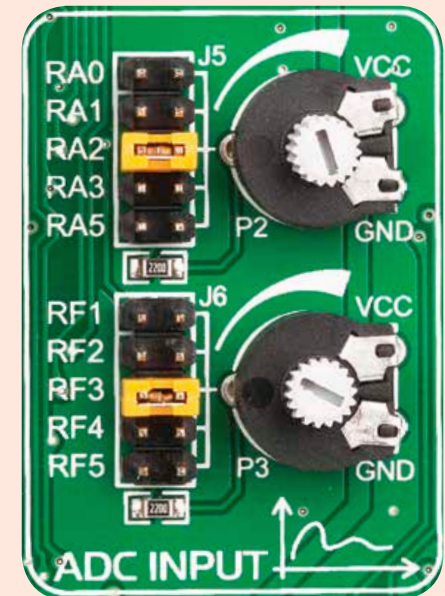

Figure 18-1: use J5 and J6 jumpers to connect analog input lines with potentiometers P2 and P3

In order to connect the output of the potentiometer **P2** to **RA0**, **RA1**, **RA2**, **RA3** or **RA5** analog microcontroller inputs, you have to place the jumper **J5** in the desired position. If you want to connect potentiometer **P3** to any of the **RF1 - RF5** analog microcontroller inputs, place jumper **J6** in the desired position. By moving the potentiometer knob, you can create voltages in range from **GND** to **VCC**.

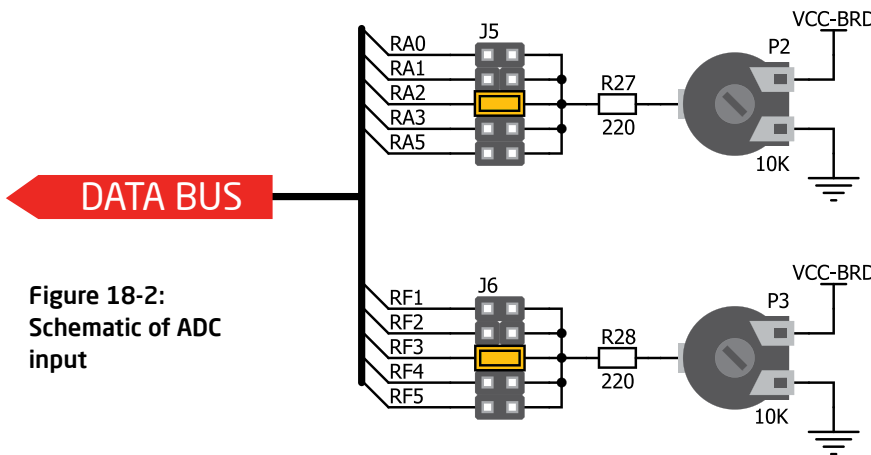

Figure 18-2: Schematic of ADC input

I²C EEPROM



Enabling I²C EEPROM

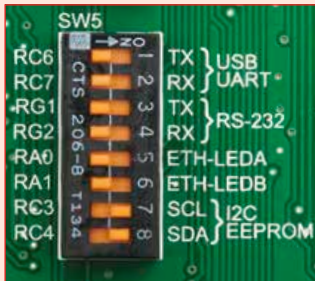
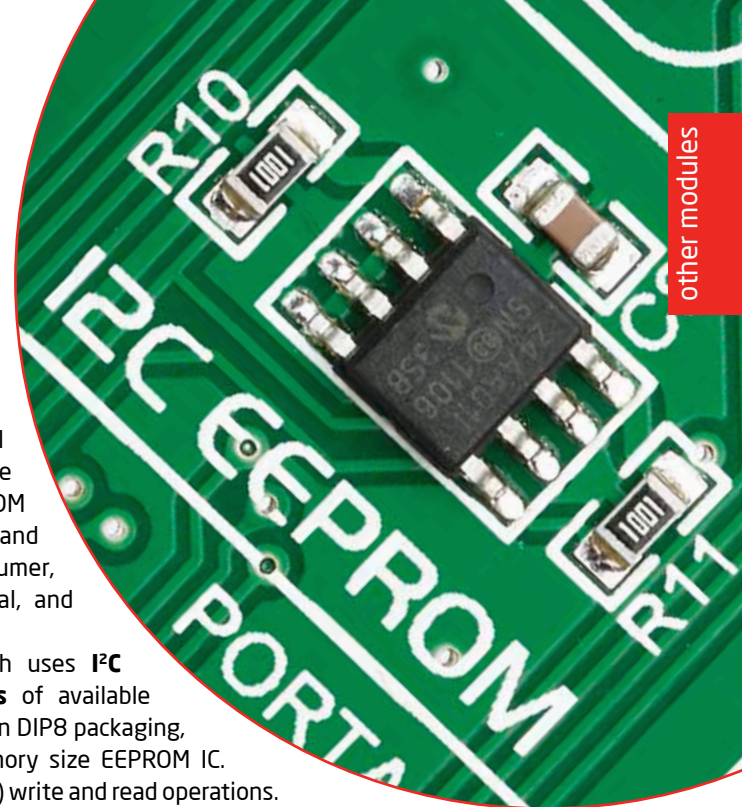

Figure 19-1: Activate SW5.7 and SW5.8 switches to enable pull-up resistors in I²C lines of Serial EEPROM.

In order to connect I²C EEPROM to the microcontroller you must enable **SW5.7** and **SW5.8** switches, as shown on **Figure 19-1**. **4K7** pull-up resistors necessary for I²C communication are already provided on **SDA** and **SCL** lines once switches are turned on. Prior to using EEPROM in your application, make sure to disconnect other peripherals, LEDs and additional pull-up or pull-down resistors from the interface lines in order not to interfere with signal/data integrity.

EEPROM is short for **Electrically Erasable Programmable Read Only Memory**. It is usually a secondary storage memory in devices containing data that is retained even if the device loses power supply. EEPROMs come with parallel or serial interface to the master device. Because of the ability to alter single bytes of data, EEPROM devices are used to store personal preference and configuration data in a wide spectrum of consumer, automotive, telecommunication, medical, industrial, and PC applications.

EasyPIC PRO™ v7 supports serial EEPROM which uses **I²C communication interface** and has **1024 bytes** of available memory. Board contains socket for serial EEPROMs in DIP8 packaging, so you can easily exchange it with different memory size EEPROM IC. EEPROM itself supports single byte or 16-byte (page) write and read operations. Data rates are dependant of power supply voltage, and go up to **1 MHz** with 5V power supply, and **400 kHz** for 3.3V power supply.



other modules

What is I²C?

I²C is a multi-master serial single-ended bus that is used to attach low-speed peripherals to computer or embedded systems. I²C uses only two open-drain lines, **Serial Data Line (SDA)** and **Serial Clock (SCL)**, pulled up with resistors. **SCL** line is driven by a master, while **SDA** is used as bidirectional line either by master or slave device. Up to 112 slave devices can be connected to the same bus. Each slave must have a unique address.

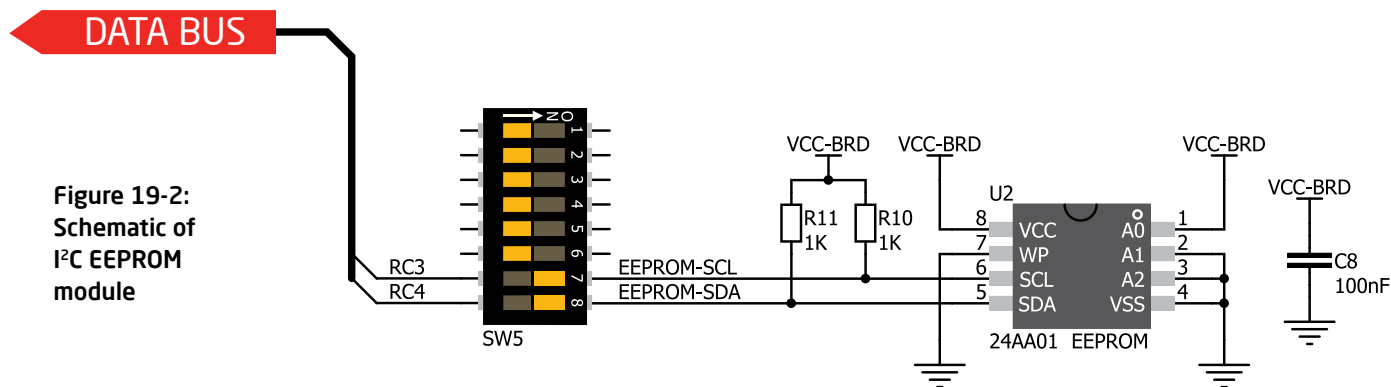

Figure 19-2: Schematic of I²C EEPROM module

Output voltages

EasyPIC PRO™ v7 contains two additional pairs of screw terminals which can be used to get power supply output for your external devices. There are two available output voltages: **5V** and **3.3V**. Depending on which power source you use (adapter, laboratory power supply, or USB), maximum output currents can vary. Power consumption of the on-board modules can also affect maximum output power which can be drawn out of the screw terminals. Big power consumers, such as Ethernet, or even GLCD with backlight can alone drastically reduce the maximum output power. On-board switching power supply can give maximum of 600mA of current if used with adapter or laboratory power supply. When used with USB power supply it can give no more than 500mA.



Figure 20-1: Output voltage terminals

Purpose of the output voltage terminals is not to be the main power source of big consumers, but more a power source for remote small consumers.

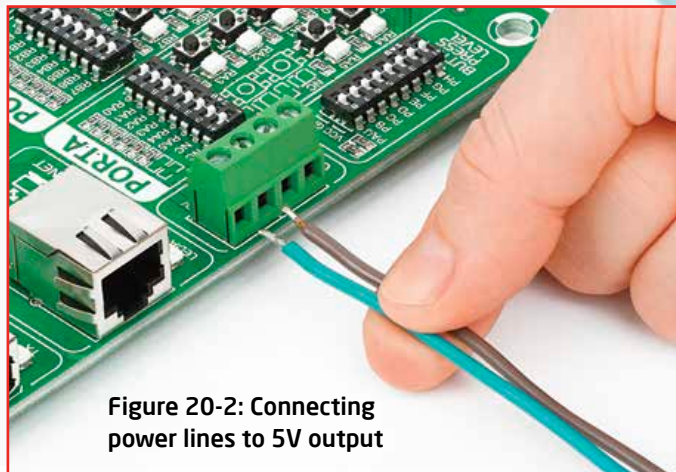

Figure 20-2: Connecting power lines to 5V output

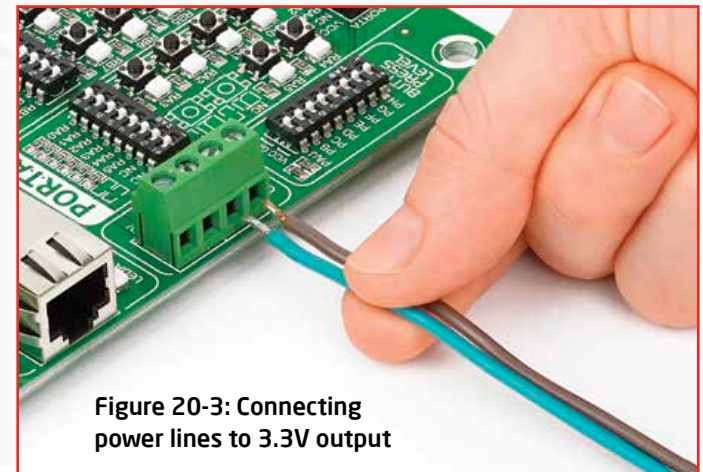

Figure 20-3: Connecting power lines to 3.3V output

Additional GNDs

EasyPIC PRO™ v7 contains three **GND pins** located in three different sections of the board, which allow you to easily connect oscilloscope GND reference when you monitor signals on microcontroller pins, or signals of on-board modules.

- 1 GND is located next to the RS-232 connector.
- 2 GND is located right to the piezo buzzer, next to PORTA header.
- 3 GND is located above PORTJ I/O group, next to PORTF header.

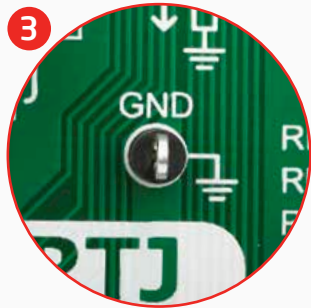
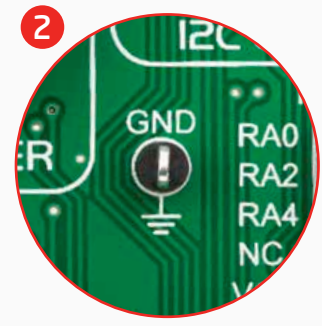
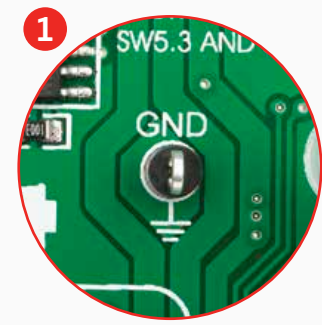
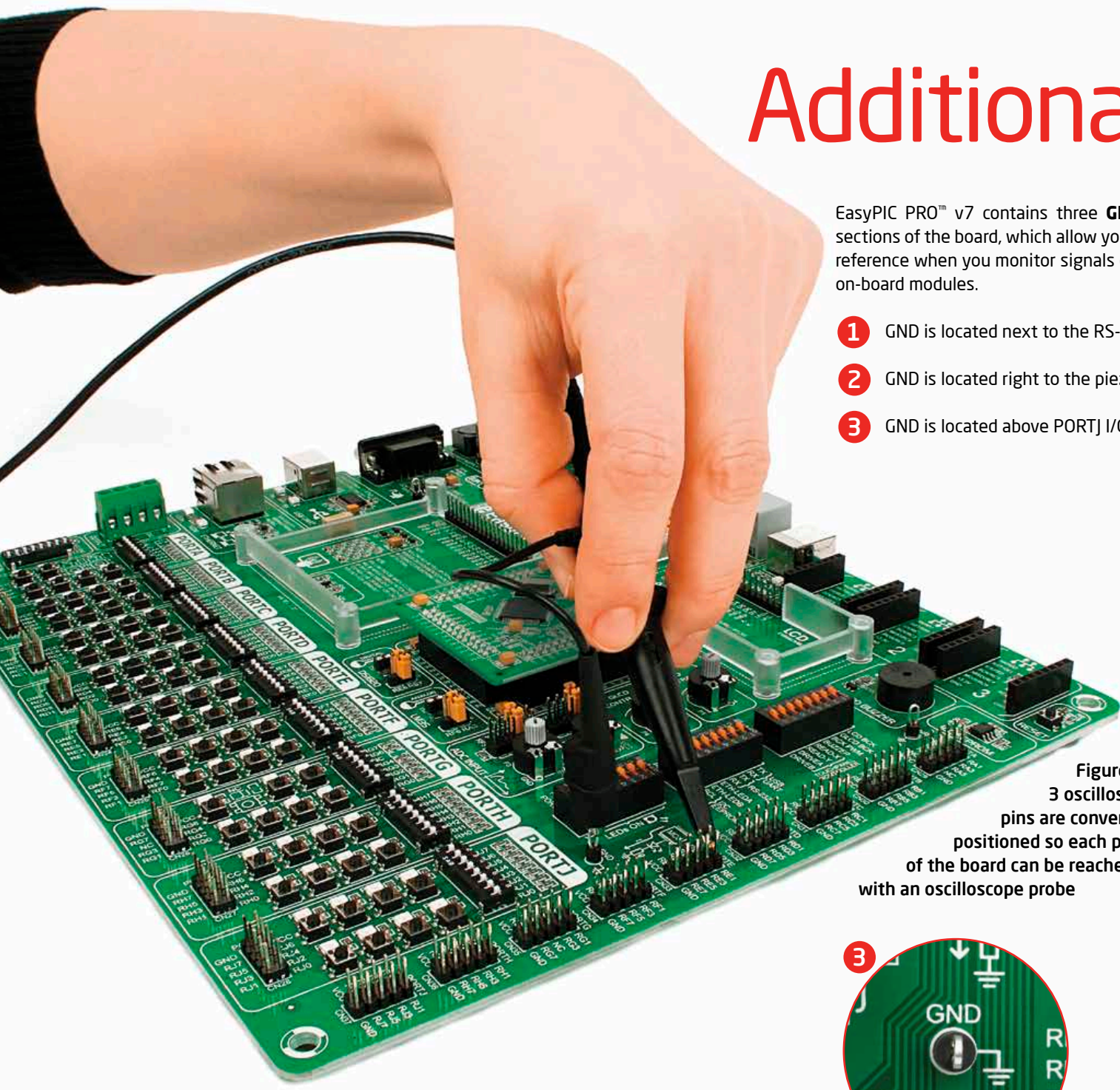

Figure 21-1:
3 oscilloscope GND pins are conveniently positioned so each part of the board can be reached with an oscilloscope probe

What's Next?

You have now completed the journey through each and every feature of **EasyPIC PRO™ v7 board**. You got to know it's modules, organization, supported microcontrollers, programmer and debugger. Now you are ready to start using your new board. We are suggesting several steps which are probably the best way to begin. We invite you to join thousands of users of EasyPIC™ brand. You will find very useful projects and tutorials and can get help from a large ecosystem of users. Welcome!

1

Compiler

You still don't have an appropriate compiler? Locate **PIC® compiler** that suits you best on our website:



www.mikroe.com/pic/compilers/

Choose between **mikroC™**, **mikroBasic™** and **mikroPascal™**, and download fully functional demo version, so you can begin building your PIC® applications.



2

Projects

Once you have chosen your compiler, and since you already got the board, you are ready to start writing your first projects. We have equipped our compilers with dozens of examples that demonstrate the use of each and every feature of the EasyPIC PRO™ v7 board, and all of our accessory boards as well. This makes an excellent starting point for your future projects. Just load the example, read well commented code, and see how it works on hardware. Browse through the compiler **Examples** available on this link:



www.mikroe.com/easypic-pro/

3

Community

If you want to find answers to your questions on many interesting topics we invite you to visit our forum at <http://www.mikroe.com/forum> and browse through more than 150 thousand posts. You are likely to find just the right information for you. On the other hand, if you want to download free projects and libraries, or share your own code, please visit the **Libstock website**. With user profiles, you can get to know other programmers, and subscribe to receive notifications on their code.



www.libstock.com/

4

Support

We all know how important it is that we can rely on someone in moments when we are stuck with our projects, facing a deadline, or when we just want to ask a simple, basic question, that's pulling us back for a while. We do understand how important this is to people and therefore our Support Department is one of the pillars upon which our company is based. MikroElektronika offers **Free Tech Support** to the end of product lifetime, so if something goes wrong, we are ready and willing to help!



www.mikroe.com/support/

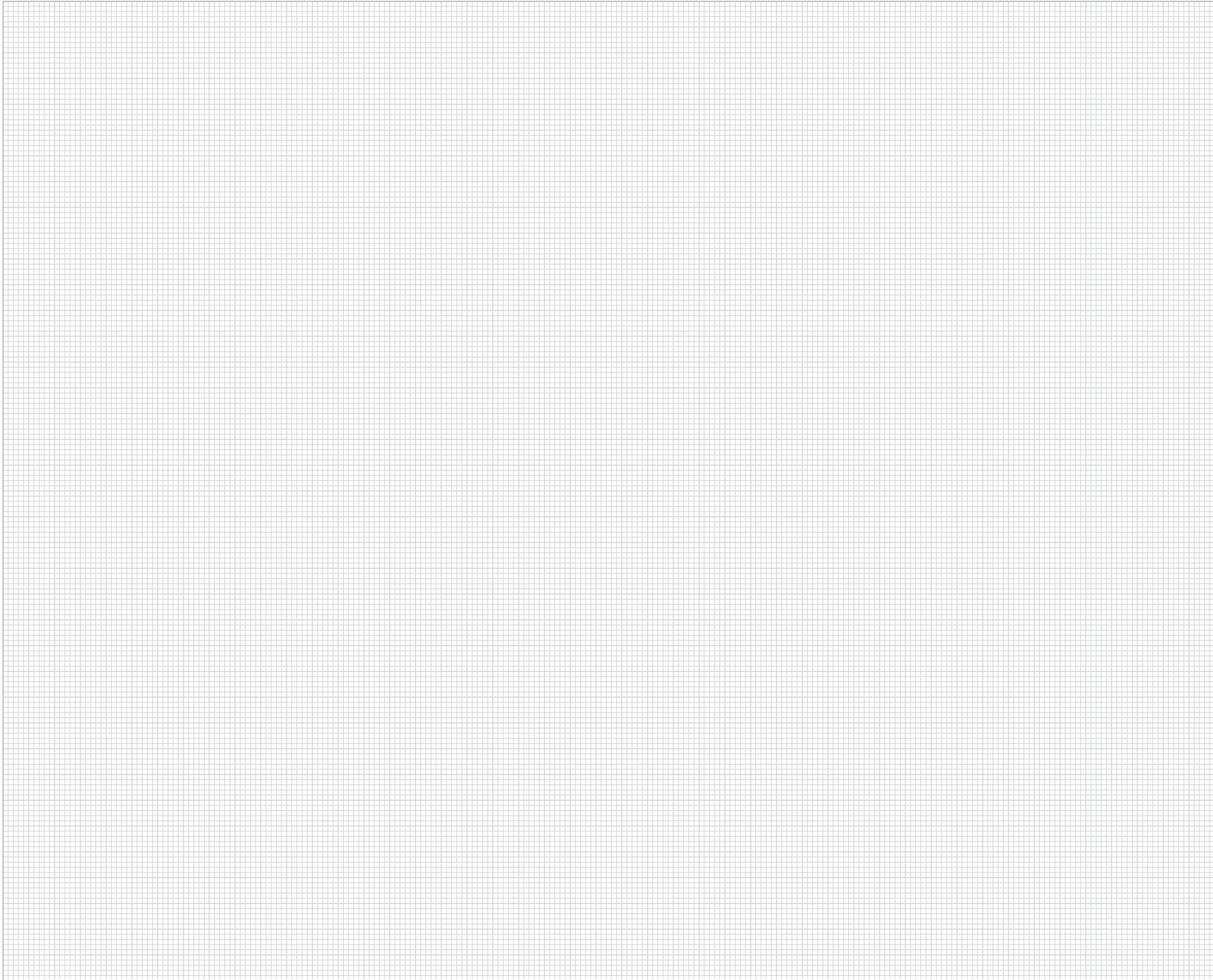

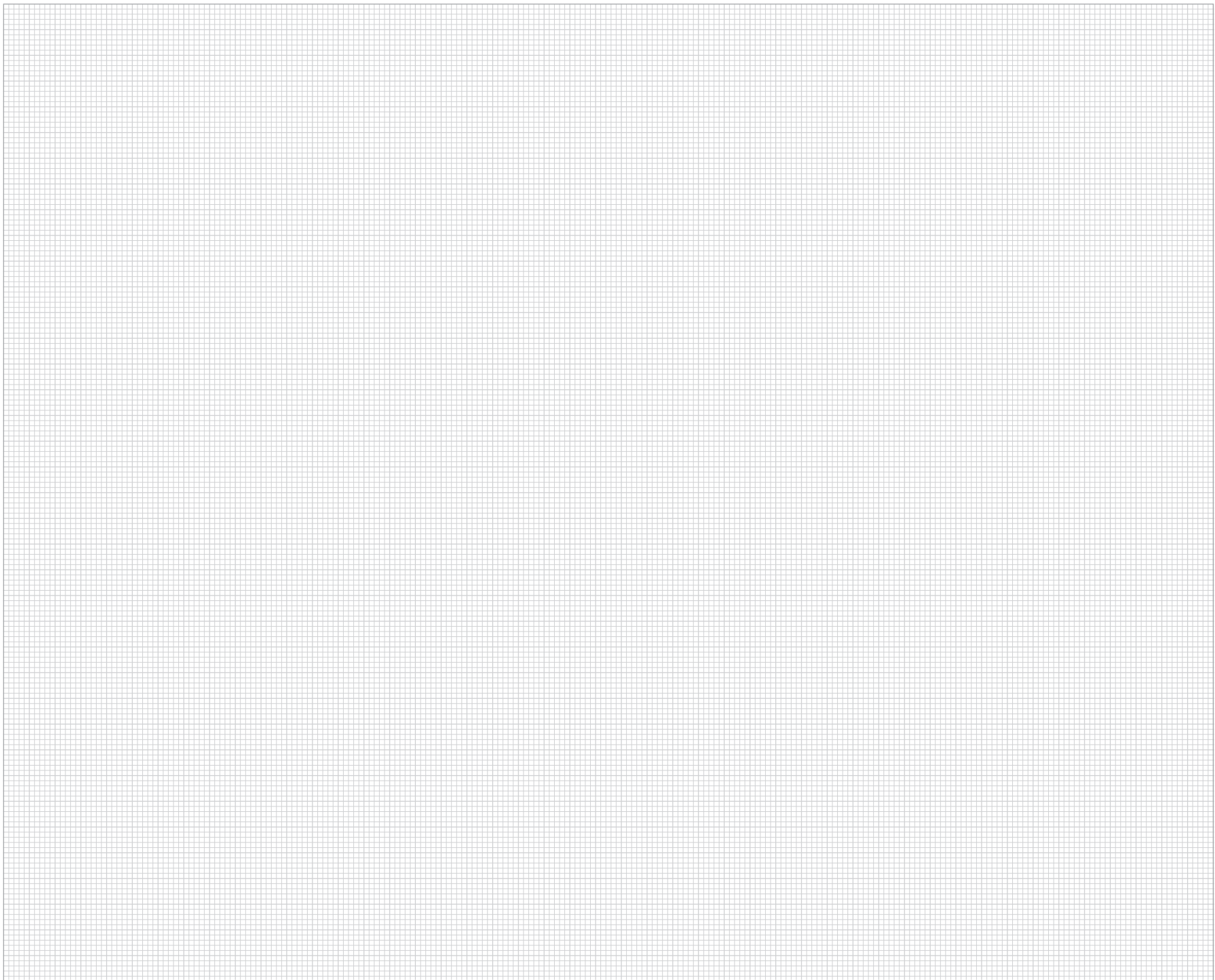

DISCLAIMER

All the products owned by MikroElektronika are protected by copyright law and international copyright treaty. Therefore, this manual is to be treated as any other copyright material. No part of this manual, including product and software described herein, must not be reproduced, stored in a retrieval system, translated or transmitted in any form or by any means, without the prior written permission of MikroElektronika. The manual PDF edition can be printed for private or local use, but not for distribution. Any modification of this manual is prohibited.

MikroElektronika provides this manual 'as is' without warranty of any kind, either expressed or implied, including, but not limited to, the implied warranties or conditions of merchantability or fitness for a particular purpose.

MikroElektronika shall assume no responsibility or liability for any errors, omissions and inaccuracies that may appear in this manual. In no event shall MikroElektronika, its directors, officers, employees or distributors be liable for any indirect, specific, incidental or consequential damages (including damages for loss of business profits and business information, business interruption or any other pecuniary loss) arising out of the use of this manual or product, even if MikroElektronika has been advised of the possibility of such damages. MikroElektronika reserves the right to change information contained in this manual at any time without prior notice, if necessary.

HIGH RISK ACTIVITIES

The products of MikroElektronika are not fault-tolerant nor designed, manufactured or intended for use or resale as on-line control equipment in hazardous environments requiring fail-safe performance, such as in the operation of nuclear facilities, aircraft navigation or communication systems, air traffic control, direct life support machines or weapons systems in which the failure of Software could lead directly to death, personal injury or severe physical or environmental damage ('High Risk Activities'). MikroElektronika and its suppliers specifically disclaim any expressed or implied warranty of fitness for High Risk Activities.

TRADEMARKS

The MikroElektronika name and logo, the MikroElektronika logo, mikroC™, mikroBasic™, mikroPascal™, mikroProg™, EasyPIC™, EasyPIC PRO™, mikroBus™ and Click boards™ are trademarks of MikroElektronika. All other trademarks mentioned herein are property of their respective companies.

All other product and corporate names appearing in this manual may or may not be registered trademarks or copyrights of their respective companies, and are only used for identification or explanation and to the owners' benefit, with no intent to infringe.

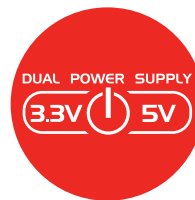
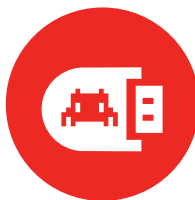

If you want to learn more about our products, please visit our website at www.mikroe.com

If you are experiencing some problems with any of our products or just need additional information, please place your ticket at www.mikroe.com/support/

If you have any questions, comments or business proposals,
do not hesitate to contact us at office@mikroe.com

EasyPIC PRO v7 Manual
ver. 1.01





Стандарт Электрон Связь

Мы молодая и активно развивающаяся компания в области поставок электронных компонентов. Мы поставляем электронные компоненты отечественного и импортного производства напрямую от производителей и с крупнейших складов мира.

Благодаря сотрудничеству с мировыми поставщиками мы осуществляем комплексные и плановые поставки широчайшего спектра электронных компонентов.

Собственная эффективная логистика и склад в обеспечивает надежную поставку продукции в точно указанные сроки по всей России.

Мы осуществляем техническую поддержку нашим клиентам и предпродажную проверку качества продукции. На все поставляемые продукты мы предоставляем гарантию .

Осуществляем поставки продукции под контролем ВП МО РФ на предприятия военно-промышленного комплекса России , а также работаем в рамках 275 ФЗ с открытием отдельных счетов в уполномоченном банке. Система менеджмента качества компании соответствует требованиям ГОСТ ISO 9001.

Минимальные сроки поставки, гибкие цены, неограниченный ассортимент и индивидуальный подход к клиентам являются основой для выстраивания долгосрочного и эффективного сотрудничества с предприятиями радиоэлектронной промышленности, предприятиями ВПК и научно-исследовательскими институтами России.

С нами вы становитесь еще успешнее!

Наши контакты:

Телефон: +7 812 627 14 35

Электронная почта: sales@st-electron.ru

Адрес: 198099, Санкт-Петербург,
Промышленная ул, дом № 19, литера Н,
помещение 100-Н Офис 331